

Metric Precision Ball Screws

High load capacity in a range of package sizes
for laboratory, medical and mechatronic applications

Metric Precision Ball Screw Overview (6 - 14 mm)

The ideal solution for laboratory, medical and mechatronic applications, Thomson's FSI, TSI and RSI Styles of metric rolled ball screws deliver smooth and quiet operation and best-in-class load capacity.

Bigger Load Capacity

- Design maximizes load capacity by optimizing return system
- Quiet and smooth performance
- Enables flexible ball nut mounting configurations and rapid prototyping
- Exceeds 100% more capacity than competitors' offerings in most sizes

Improved Value

- Screws are precision rolled to T7 accuracy class standard
- State-of-the-art manufacturing
- Higher load capacity equates to longer life

Genuine Thomson Quality and Innovation

- Proprietary thread form and processing equal quality and performance
- Expert technical and application support

Ball Nut Types

Styles	Nominal Diameter Size Range (mm)
Flanged Single Nut Internal Return System (FSI)	6 - 50
Threaded Single Nut Internal Return System (TSI)	6 - 14
Rounded Single Nut Internal Return System (RSI)	6 - 14



Materials

Part	Material		Strength		Heat treatment	Standard Surface Finish
	16 - 50 mm (FSI)	6 - 14 mm (FSI, TSI, RSI)	R _m	R _e		
			[N/mm ²]	[N/mm ²]		
Screw	Cf53	SAE1045	≥ 610	≥ 380	60 ± 2 HRC Inductive hardening	Polished & Oiled
Nut	16MnCr5	SAE8620	> 800	> 600	60 ± 2 HRC hardened	Polished & Oiled (optional black oxide)
Wiper	NBR 33					
Ball	100Cr6	SAE52100			64 ± 2 HRC	

Special materials and heat or surface treatment on request.

Permitted temperature in continuous operation -22°F (-30°C) to 212°F (100°C). Please inquire for other applications.

Nuts with plastic ball returns only to 176°F (80°C); briefly 230°F (110°C).

Miniature FSI, TSI & RSI Styles Ball Screws – Product Availability

Nominal Diameter	Screw Leads									
	[mm]	2 mm	2.5 mm	3 mm	4 mm	5 mm	10 mm	20 mm	25 mm	40 mm
6		•								
8		•	•	•						
10		•		•	•		•			
12		•		•						
14				•						

Standard FSI Style Ball Screws - Product Availability

16					•	•				
20					•					
25					•	•	•	•		
32					•	•	•			
40					•	•	•			•
50						•				

Standard FSI Style (16 - 50 mm)

FSI Style metric ball screws combine the engineering and performance of high-quality, German ball screws with North American manufacturing and logistics. Only 2% of all ball screws sold in North America are manufactured here, so you'll be able to take advantage of shorter lead times, reduced shipping costs, and enhanced communication with support and service. The FSI Style provides the best in quality, performance and delivery at a competitive price.

German Engineered

- DIN 69051 compliant (FSI Style 16 - 50 mm only)
- Patented Precision Screw Forming (PST) technology
- Smooth performance due to unique ball return systems

North American Manufacturing and Technical Support

- Regionally stocked/machined/assembled product
 - Tijuana, Mexico to support West Coast
 - Marengo, Illinois to support East Coast
- P5 accuracy screws standard
- Ground quality ball nuts



FSI Style Application Examples

Thomson's FSI ball screw assemblies provide the smooth motion and positional accuracy typically found only in a ground product. These qualities, combined with the economical precision rolled solution, make them ideal for large 3-axis structures.

Gantry

Thomson's unique ball return systems and preload capabilities reduce the effect of critical screw speed on a long slender axis (see X-axis above). Combined with the Thomson profile rail, this solution provides stiffness and accuracy to the overall system.

Smooth motion is necessary to prevent reflected inertia from causing structural vibration in large structures. The illustrated Y-axis below combines a precision FSI ball screw assembly with the alignment compensation of Thomson linear rails.



Engraver / Laser / Waterjet Cutting

Machine tool applications have primarily been the domain of ground ball screw assemblies. The introduction of high-precision P3/P5 accuracy rolled ball screws has eliminated the need for ground product where a less expensive solution that still meets high performance standards is required.

These types of applications typically require P3/P5 accuracy, 75-100% duty cycle, harsh environments, and reversing loads or dithering issues. FSI ball screw assemblies have molded rubber (NBR) seals as standard in sizes $\varnothing 16$ mm and above and are ideal for these demanding parameters.

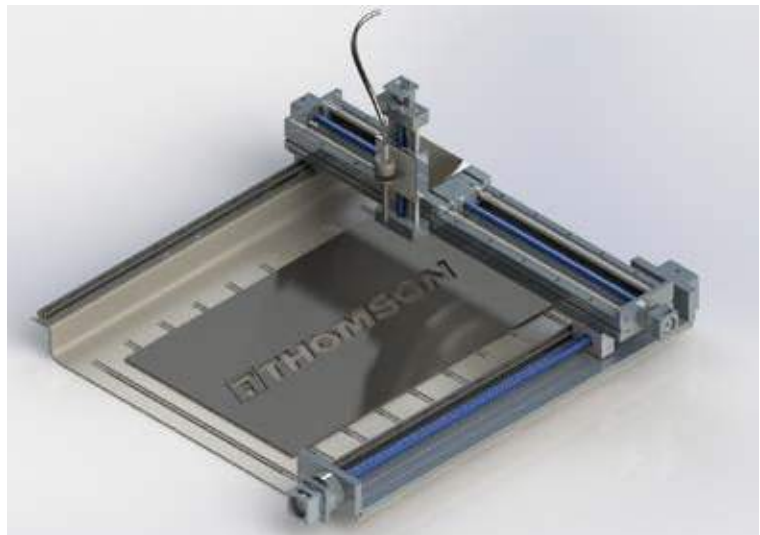

Metric Ball Nut Return System Overview

All ball screws require a recirculation system for the ball bearings. Thomson return systems are optimized for each diameter and lead combination to maximize load capacity, minimize footprint and guarantee smooth operation.

Single Return (E = Single Liner, M = Multi Liner)

For single-start ball screws

After each turn, the balls are lifted from the shaft raceway and set back by a single turn. Thomson NEFF return systems made from glass-fiber reinforced plastic or steel guarantee a faultless and gentle recirculation of the balls.

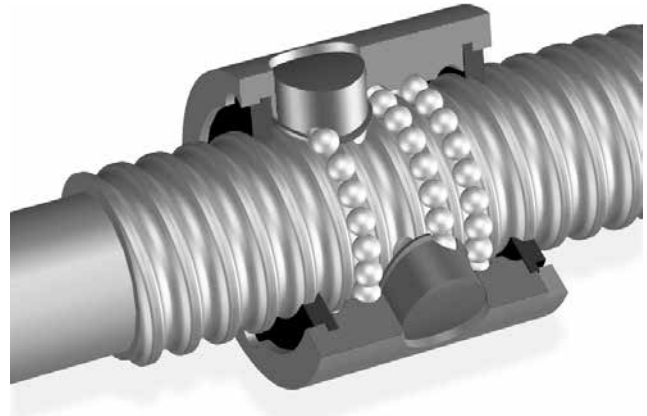

Internal Return (K = Channel)

For single-start and multiple-start ball screws.

After several turns, the balls are returned either by a patented plastic recirculation system integrated into the nut or through recirculation channels also integrated into the nut using steel recirculation inserts.

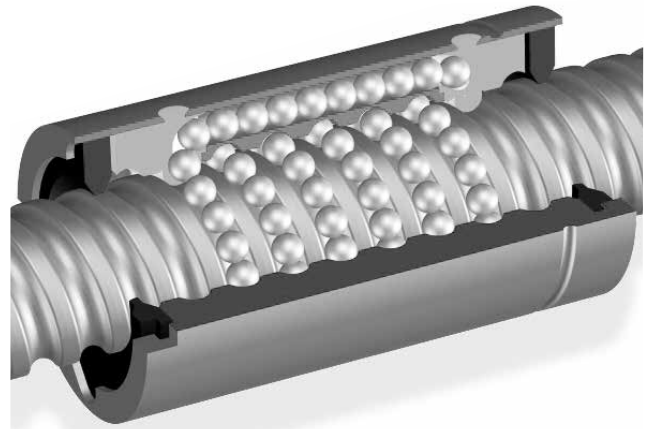

External Return (D = End Cap)

For multiple-start ball screws.

The balls are recirculated via two special end caps and return channels integrated into the nut.

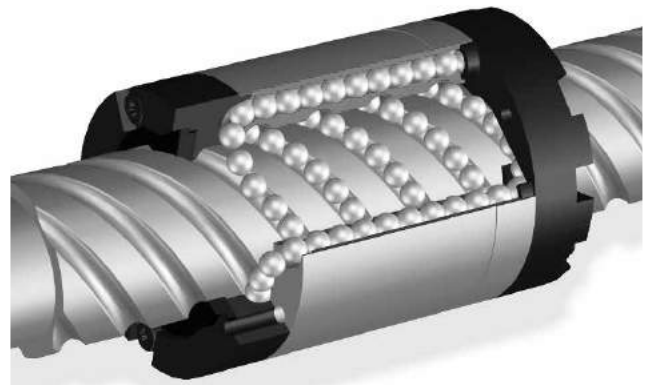

Bearing Supports Product Overview

Metric Ball Screws

Diameter	BK	BF	FK	FF	MK	WK
12	7833391	7833398	7833405	7833411	7833700	-
16	7833392	7833399	7833406	7833412	7833701	-
20	7833393	7833400	7833407	7833413	7833702	-
25	7833394	7833401	7833408	7833414	7833703	7833614
32	7833395	7833402	7833409	7833415	-	7833615
40	7833396	7833403	7833410	7833416	-	7833617
50	7833397	7833404	-	-	-	7833621



BK Bearing Support ^{(1), (2)}

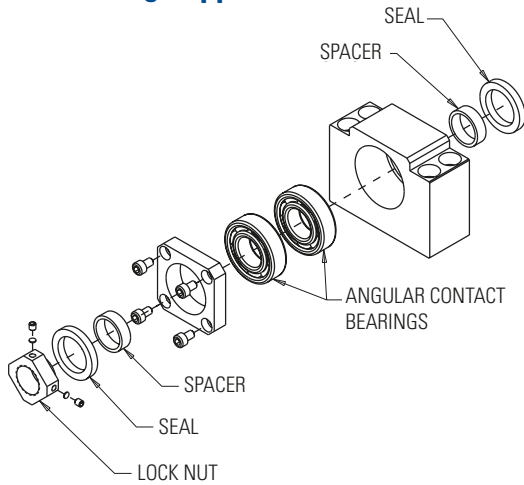

The base mounted BK Bearing Support contains an angular contact bearing pair for increased stiffness and axial load capacity. Design dimensions fit standard Type BK or BK1 end machining.

FK Bearing Support ^{(1), (2)}

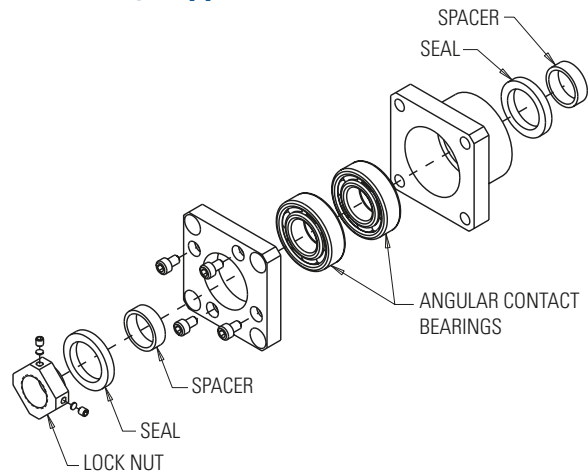

The flange-mounted FK Bearing Support contains an angular contact bearing pair for increased stiffness and axial load capacity. Design dimensions fit standard Type FK or FK1 end machining.

BF Bearing Support ^{(1),(3)}

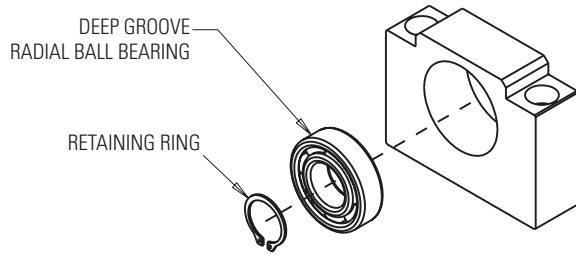

Base-mounted BF Bearing Support contains a floating radial bearing to allow axial shaft movement. Design dimensions fit standard Type BF or BF1 end machining.

FF Bearing Support ^{(1),(3)}

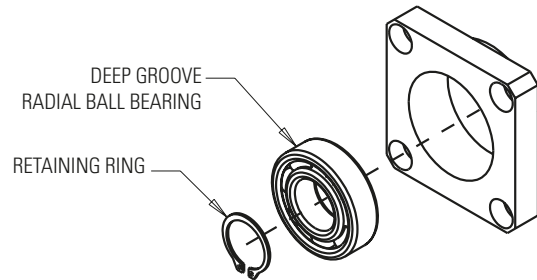

The flange-mounted FF Bearing Support contains a floating radial bearing to allow axial shaft movement. Design dimensions fit standard Type FF or FF1 end machining.

MK Bearing Support ⁽²⁾

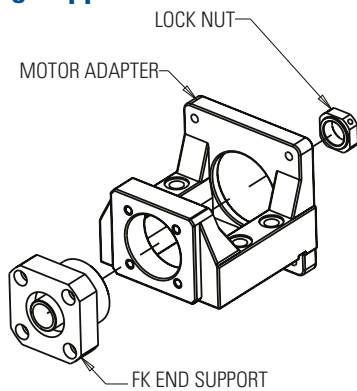

Base-mounted NEMA 23 or 34 motor mount. Design dimensions fit standard Type FK end machining.

WK Bearing Support ⁽²⁾

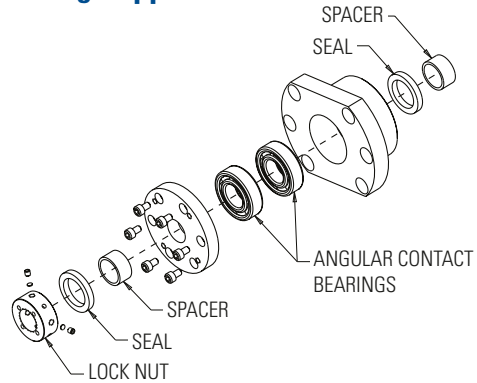

Heavy duty, flange-mounted WK support contains higher load capacity bearings. Design dimensions fit standard WK or WK1 end machining.

(1) BK, FK, MK and WK supports are classified as "fixed," and BF and FF supports are classified as "simple" for purposes of critical speed and column strength calculations.

(2) Locknut included in assembly

(3) Retaining ring included in assembly

FSI Style Ball Nuts – Technical Specifications



Standard Lead Accuracy: $\pm 23 \mu\text{m} / 300 \text{mm}^{(1)}$

Internal Return Flanged Ball Nut and Screw

- Flexible solution for standard mounting
- Integral wiper ($\geq 16 \text{mm}$) and flange included as standard
- Available in two preload classes (Type Z2, Z3)
 - Z2 – no preload, clearance held to max indicated in table (standard unless specified)
 - Z3 – no preload, clearance held to max 0.05 mm (16 - 50 mm) or max 0.013 mm (6 - 14 mm)

Technical Specifications

Nom. Diameter	Lead	Nut Form	Return System	Ball Nut P/N	Ball Screw P/N	Performance Data					Screw Specifications				
						Dynamic Load Capacity		Static Load Capacity		Max Axial Backlash	Major Diameter	Minor Diameter	Std Length	Max Length	Screw Weight
						[kN]	[lbs]	[kN]	[lbs]						
6	2	M	M	8102-448-035	190-9684	1.6	360	2.1	472	0.05	5.9	4.9	1000	1000	0.22
8	2	M	M	8103-448-036	190-9685	2.3	517	2.9	652	0.05	7.8	6.3	1500	1500	0.38
8	2.5	M	M	8103-448-037	190-9686	3.1	697	4.0	899	0.05	7.8	6.3	1500	1500	0.38
8	3	M	M	8103-448-038	190-9687	2.7	607	3.1	697	0.05	7.7	5.9	1500	1500	0.37
10	2	M	M	8103-448-039	190-9680	2.7	607	3.8	854	0.05	9.8	8.3	1900	1900	0.59
10	3	M	M	8103-448-040	190-9681	6.7	1506	9.6	2158	0.05	9.7	8.0	1900	1900	0.58
10	4	M	M	8103-448-041	190-9688	5.8	1304	8.2	1844	0.05	9.7	7.9	1900	1900	0.58
10	10	M	K	8103-448-042	190-9689	4.1	922	5.8	1304	0.05	9.7	7.9	1900	1900	0.58
12	2	M	M	8105-448-043	190-9690	4.5	1012	7.6	1709	0.05	11.8	10.3	1900	1900	0.86
12	3	M	M	8105-448-044	190-9691	9.6	2158	16.4	3687	0.05	11.7	9.9	1900	1900	0.85
14	3	M	M	8105-448-047	190-9692	6.7	1506	11.6	2608	0.05	13.7	12.0	1900	1900	1.16
16	5	E	E	7106-448-061	195-9698	9.3	2091	13.1	2945	0.08	15.3	12.9	4000	6000	1.30
16	10	E	K	7106-448-062	195-9699	15.4	3462	26.5	5958	0.08	15.2	13.0	4000	6000	1.30
20	5	E	K	7107-448-063	195-9700	10.5	2361	16.6	3732	0.08	19.3	16.9	4000	6000	2.00
25	5	E	E	7110-448-064	195-9701	12.3	2765	22.5	5058	0.08	24.3	21.9	4000	6000	3.30
25	10	E	K	7110-448-065	195-9702	13.2	2968	25.3	5688	0.08	24.3	21.9	4000	6000	3.30
25	20	S	D	7110-448-066	195-9703	13.0	2923	23.3	5238	0.15	24.4	22.0	4000	6000	3.30
25	25	S	D	7110-448-067	195-9704	16.7	3754	32.2	7239	0.08	24.3	22.0	4000	6000	3.30
32	5	E	E	7112-448-069	195-9706	21.5	4834	49.3	11084	0.08	31.3	28.9	4000	6000	5.60
32	10	E	E	7112-448-070	195-9707	33.4	7509	54.5	12253	0.08	32.5	27.3	4000	6000	5.60
32	20	E	K	7112-448-071	195-9708	29.7	6677	59.8	13444	0.08	31.5	27.9	4000	6000	5.60
40	5	E	E	7115-448-073	195-9710	23.8	5351	63.1	14186	0.08	39.3	36.9	4000	6000	9.00
40	10	E	E	7115-448-074	195-9711	38.0	8543	69.1	15535	0.08	39.3	34.1	4000	6000	8.40
40	20	E	K	7115-448-075	195-9712	33.3	7487	76.1	17109	0.08	39.5	35.9	4000	6000	9.00
40	40	S	D	7115-448-076	195-9713	35.0	7869	101.9	22909	0.08	38.7	36.3	4000	6000	9.00
50	10	E	E	7120-448-077	195-9714	68.7	15445	155.8	35027	0.08	49.3	44.1	4000	6000	13.50

1. P3 accuracy class is $\pm 12 \mu\text{m} / 300 \text{mm}$ and is available upon request. 2. Dimension does not comply with DIN 69051. 3. Round flange.

FSI Style Ball Nuts – Technical Specifications

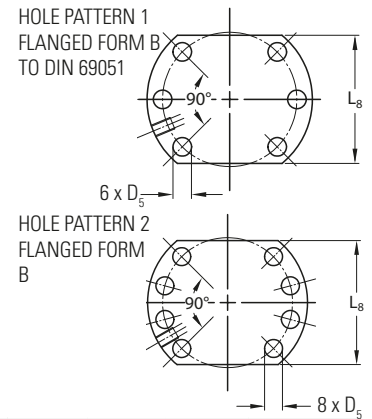
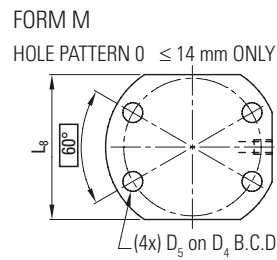
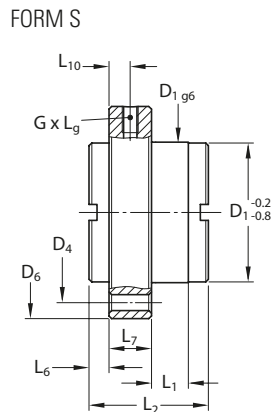
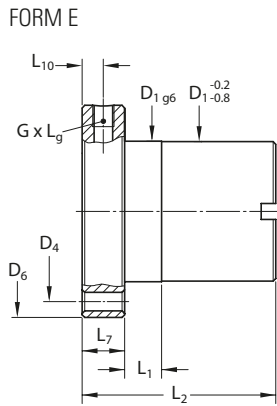

Technical Specifications

	Nom. Diameter	Lead	Hole Pattern	Nut Specifications													Lube Hole (G)	No. of Circuits	Ball Diameter
				D1 g6	D4	D5	D6	L1	L2	L6	L7	L8	L10						
	[mm]	[mm]		[mm]	[mm]	[mm]	[mm]	[mm]	[mm]	[mm]	[mm]	[mm]	[mm]	[mm]			[mm]		
	6	2	0	12	18	3.4	24	-	22	-	4	16	-	-	-	8	1.000		
	8	2	0	16	22	3.4	28	-	24	-	6	19	-	-	-	5	1.588		
	8	2.5	0	16	22	3.4	28	-	24	-	6	19	-	-	-	7	1.588		
	8	3	0	16	22	3.4	28	-	25	-	6	19	-	-	-	3	1.984		
	10	2	0	18	28	4.5	36	-	22	-	6	22	-	-	-	5	1.588		
	10	3	0	18	28	4.5	36	-	29	-	6	22	-	-	-	7	1.984		
	10	4	0	18	28	4.5	36	-	35	-	6	22	-	-	-	6	1.984		
	10	10	0	23	31	4.5	38	-	35	-	6	24	-	-	-	2 x 1.8	1.984		
	12	2	0	20	29	4.5	37	-	40	-	8	24	-	-	-	8	1.588		
	12	3	0	20	29	4.5	37	-	40	-	8	24	-	-	-	9	1.984		
	14	3	0	24	36	5.5	45	-	35	-	8	28	-	-	-	5	1.984		
	16	5	1	28	38	6	48	10	42	-	10	40	5	M6x1	3	3.500			
	16	10	1	28	38	6	48	10	55	-	10	40	5	M6x1	6	3.000			
	20	5	1	36	47	7	58	10	42	-	10	44	5	M6x1	3	3.500			
	25	5	1	40	51	7	62	10	42	-	10	48	5	M6x1	3	3.500			
	25	10	1	40	51	7	62	16	55	-	10	48	5	M6x1	3	3.500			
	25	20	1	40	51	7	62	4	35	10.5	10	48	5	M6x1	4	3.500			
	25	25	1	40	51	7	62	9	35	8	10	N/A ^[3]	5	M6x1	5	3.500			
	32	5	1	50	65	9	80	10	55	-	12	62	6	M6x1	5	3.500			
	32	10	1	53 ^[2]	65	9	80	16	69	-	12	62	6	M8x1	3	7.140			
	32	20	1	53 ^[2]	65	9	80	16	80	-	12	62	6	M6x1	4	5.000			
	40	5	2	63	78	9	93	10	57	-	14	70	7	M6x1	5	3.500			
	40	10	2	63	78	9	93	16	71	-	14	70	7	M8x1	3	7.140			
	40	20	2	63	78	9	93	16	80	-	14	70	7	M8x1	4	5.000			
	40	40	2	63	78	9	93	16	85	7.5	14	N/A ^[3]	7	M8x1	8	3.500			
	50	10	2	75	93	11	110	16	95	-	16	85	8	M8x1	5	7.140			

TSI Style Ball Nuts – Technical Specifications



Standard Lead Accuracy: $\pm 52 \mu\text{m} / 300 \text{ mm}$

Internal Return Threaded Ball Nut and Screw

- Cost-effective solution in a small envelope, ideal for use in small spaces
- Flexible solution for non-standard mounting
- Available in two preload classes (Type Z2 or Z3)
 - Z2 – no preload, clearance held to max indicated in table (standard unless specified)
 - Z3 – no preload, clearance held to max 0.013 mm

Technical Specifications

Nom. Diameter	Lead	Return System	Ball Nut P/N	Ball Screw P/N	Performance Data				
					Dynamic Load Capacity		Static Load Capacity		Max. Axial Backlash
					[kN]	[lbs]	[kN]	[lbs]	
6	2	M	8102-448-025	190-9684	1.6	360	2.1	472	0.05
8	2	M	8103-448-026	190-9685	2.3	517	2.9	652	0.05
8	2.5	M	8103-448-027	190-9686	3.1	697	4.0	899	0.05
8	3	M	8103-448-028	190-9687	2.7	607	3.1	697	0.05
10	2	M	8103-448-022	190-9680	2.7	607	3.8	854	0.05
10	3	M	8103-448-023	190-9681	6.7	1506	9.6	2158	0.05
10	4	M	8103-448-029	190-9688	5.8	1304	8.2	1844	0.05
10	10	K	8103-448-030	190-9689	4.1	922	5.8	1304	0.05
12	2	M	8105-448-031	190-9690	4.5	1012	7.6	1709	0.05
12	3	M	8105-448-032	190-9691	9.6	2158	16.4	3687	0.05
14	3	M	8105-448-033	190-9692	6.7	1506	11.6	2608	0.05

TSI Style Ball Nuts – Technical Specifications

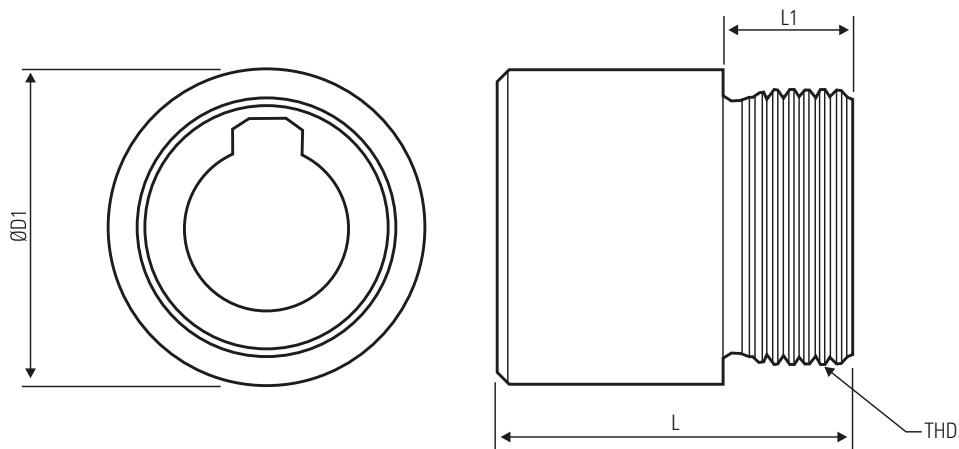

	Screw Specifications				Nut Specifications					
	Major Diameter	Minor Diameter	Std Length	Screw Weight	L	D1 0/-1	THD	L1	No. of Circuits	Ball Diameter
	[mm]	[mm]	[mm]	[kg/m]	[mm]	[mm]		[mm]		[mm]
	5.9	4.9	1000	0.22	22	16	M12 x 1	8	8	1.000
	7.8	6.3	1500	0.38	24	18	M15 x 1	8	5	1.588
	7.8	6.3	1500	0.38	24	18	M15 x 1	8	7	1.588
	7.7	5.9	1500	0.37	25	18	M16 x 1	8	3	1.984
	9.8	8.3	1900	0.59	22	19.5	M17 x 1	8	5	1.588
	9.7	8.0	1900	0.58	29	21	M18 x 1	9	7	1.984
	9.7	7.9	1900	0.58	35	21	M18 x 1	9	6	1.984
	9.7	7.9	1900	0.58	35	23	M18 x 1	9	2x1.8	1.984
	11.8	10.3	1900	0.86	40	24	M20 x 1	10	8	1.588
	11.7	9.9	1900	0.85	40	26	M20 x 1	10	9	1.984
	13.7	12.0	1900	1.16	35	30	M24 x 1.5	9	5	1.984

RSI Style Ball Nuts – Technical Specifications



Standard Lead Accuracy: $\pm 52 \mu\text{m} / 300 \text{ mm}$

Internal Return Threaded Ball Nut and Screw

- Cost-effective solution in a small envelope, ideal for use in small spaces
- Flexible solution for non-standard mounting
- Available in two preload classes (Type Z2 or Z3)
 - Z2 – no preload, clearance held to max indicated in table (standard unless specified)
 - Z3 – no preload, clearance held to max 0.013 mm

Technical Specifications

Nom. Diameter	Lead	Return System	Ball Nut P/N	Ball Screw P/N	Performance Data				
					Dynamic Load Capacity		Static Load Capacity		Max. Axial Backlash
					[kN]	[lbs]	[kN]	[lbs]	
6	2	M	8102-448-048	190-9684	1.6	360	2.1	472	0.05
8	2	M	8103-448-049	190-9685	2.3	517	2.9	652	0.05
8	2.5	M	8103-448-050	190-9686	3.1	697	4.0	899	0.05
8	3	M	8103-448-051	190-9687	2.7	607	3.1	697	0.05
10	2	M	8103-448-052	190-9680	2.7	607	3.8	854	0.05
10	3	M	8103-448-053	190-9681	6.7	1506	9.6	2158	0.05
10	4	M	8103-448-054	190-9688	5.8	1304	8.2	1844	0.05
10	10	K	8103-448-055	190-9689	4.1	922	5.8	1304	0.05
12	2	M	8105-448-056	190-9690	4.5	1012	7.6	1709	0.05
12	3	M	8105-448-057	190-9691	9.6	2158	16.4	3687	0.05
14	3	M	8105-448-060	190-9692	6.7	1506	11.6	2608	0.05

RSI Style Ball Nuts – Technical Specifications

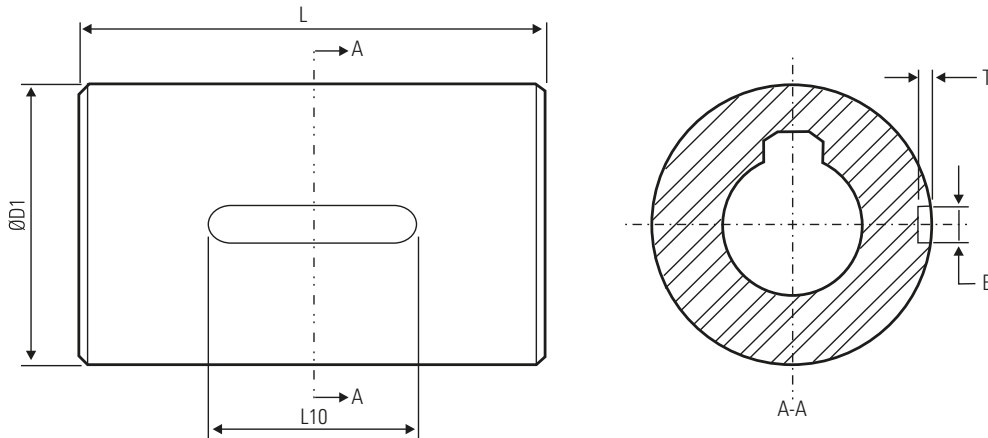

	Screw Specifications				Nut Specifications					
	Major Diameter	Minor Diameter	Std Length	Screw Weight	L	D1 g6	B x T P9	L10	No. of Circuits	Ball Diameter
	[mm]	[mm]	[mm]	[kg/m]	[mm]	[mm]		[mm]		[mm]
	5.9	4.9	1000	0.22	22	16	2 x 1.2	10	8	1.000
	7.8	6.3	1500	0.38	24	18	3 x 2	13	5	1.588
	7.8	6.3	1500	0.38	24	18	3 x 2	13	7	1.588
	7.7	5.9	1500	0.37	25	18	3 x 2	13	3	1.984
	9.8	8.3	1900	0.59	22	19.5	3 x 2	13	5	1.588
	9.7	8.0	1900	0.58	29	21	3 x 2	13	7	1.984
	9.7	7.9	1900	0.58	35	21	3 x 2	13	6	1.984
	9.7	7.9	1900	0.58	35	23	3 x 2	13	2x1.8	1.984
	11.8	10.3	1900	0.86	40	24	3 x 2	18	8	1.588
	11.7	9.9	1900	0.85	40	26	3 x 2	18	9	1.984
	13.7	12.0	1900	1.16	35	30	4 x 2.5	19	5	1.984

How to Order Metric Precision Rolled Ball Screws

This ordering key provides a quick overview of the FSI, TSI and RSI Style versions available. To explore additional technical resources and options, contact Thomson customer support.

Ordering Key																	
1	2	3	4		5		6	7	8		9	10		11	12		13
RM	25	10	Z2	-	xxxx	-	F	L	W	-	BK	S	-	K	X	-	
1. Nut Configuration RM = RH, Metric	2. Diameter 06 = Ø 6 mm 08 = Ø 8 mm 10 = Ø 10 mm 12 = Ø 12 mm 14 = Ø 14 mm 16 = Ø 16 mm 20 = Ø 20 mm 25 = Ø 25 mm 32 = Ø 32 mm 40 = Ø 40 mm 50 = Ø 50 mm	3. Lead Code 02 = 2 mm 02.5 = 2.5 mm 03 = 3 mm 04 = 4 mm 05 = 5 mm 10 = 10 mm 20 = 20 mm 25 = 25 mm 40 = 40 mm	4. Backlash Z2 = Standard backlash (see Technical Specifications) Z3 = Minimum backlash (see Technical Specifications)	5. Overall Length xxxx.xx = Length (mm)	6. Nut interface F = Flanged nut (FS) style (6 - 50 mm) T = Threaded nut (TSI) style (6 - 14 mm) R = Round nut (RSI) style with keyway (6 - 14 mm)	7. Nut Direction R = Nut faces right end L = Nut faces left end	8. Wipers X = No wipers (6 - 14 mm) W = Plastic wipers (16 - 50 mm)	9/11. Left/Right Side Configuration X = Cut to length K = Machine to print yyy = Annealed Length (mm) BK = Base mount w/Drive BK1 = Base mount w/o Drive BF = Floating base mount w/Drive BF1 = Floating base mount w/o Drive FK = Flange mount w/Drive FK1 = Flange mount w/o Drive FF = Floating flange mount w/Drive FF1 = Floating flange mount w/o Drive WK = HD Flange w/ Drive WK1 = HD Flange w/o Drive MK = Motor mount	10/12. Left/Right Bearing Support Blank = Annealed end X = No Support S = Support BK, etc.	13. Custom Modifier Blank = Standard M = Custom (1) Custom only, contact customer support.							
Code Example: RM2510Z2-271.5-FLW-BKS-KX This describes a standard lashed Ø25 x 10 mm FSI ball screw assembly that is 271.5 mm in overall length with a BK driven bearing support on the left side and custom specified machining on the right side without bearing support. The flange faces the left side with the BK bearing support. NOTE: Not all bearing supports are available in all sizes. See catalog or contact customer support for available combinations.																	

Express Prototypes, Less Lead Time

Prices and lead times are generally higher with other products as 98% of rolled metric ball screws are manufactured outside of North America.

Thomson provides expert application support and the ability to rapidly prototype designs by combining North American manufacturing of metric products with the engineering support of a trusted brand.

Don't pay extra to wait.

Order your Thomson prototype with delivery from our North American facilities in Tijuana or Marengo:

	Standard Lead Time	Express Lead Time (Qualified Prototypes)
Components	1 - 3 days	Same day
Machined Assemblies	1 - 2 weeks	3 - 5 days

Customized Products and Machining to Fit Your Applications

FSI Standard (16 - 50 mm) Metric Ball Screws

- Custom coatings available (thin dense chrome)
- $\pm 12 \mu\text{m}/300 \text{ mm}$ lead accuracy (P3)
- Reduced backlash (0.05 mm)
- All Thomson Neff products (KGF-D, KGF-N, KGM-D, KGM-N, ZG, FH/FK) are available and compatible with FSI metric ball screws



FSI, TSI & RSI Miniature Ball Screws

- Stainless steel construction
- Custom coatings available (thin dense chrome)
- $\pm 23 \mu\text{m}/300 \text{ mm}$ lead accuracy (T5 / P5)
- Reduced backlash (0.013 mm)

Standard and custom machining



Precision end journal machining to standard or customer specified requirements using CNC lathe and grinding.



State-of-the-art dynamic lead error verification to P3 accuracy.

Ball Screw Engineering

Acceptable Speed vs. Length for Screws

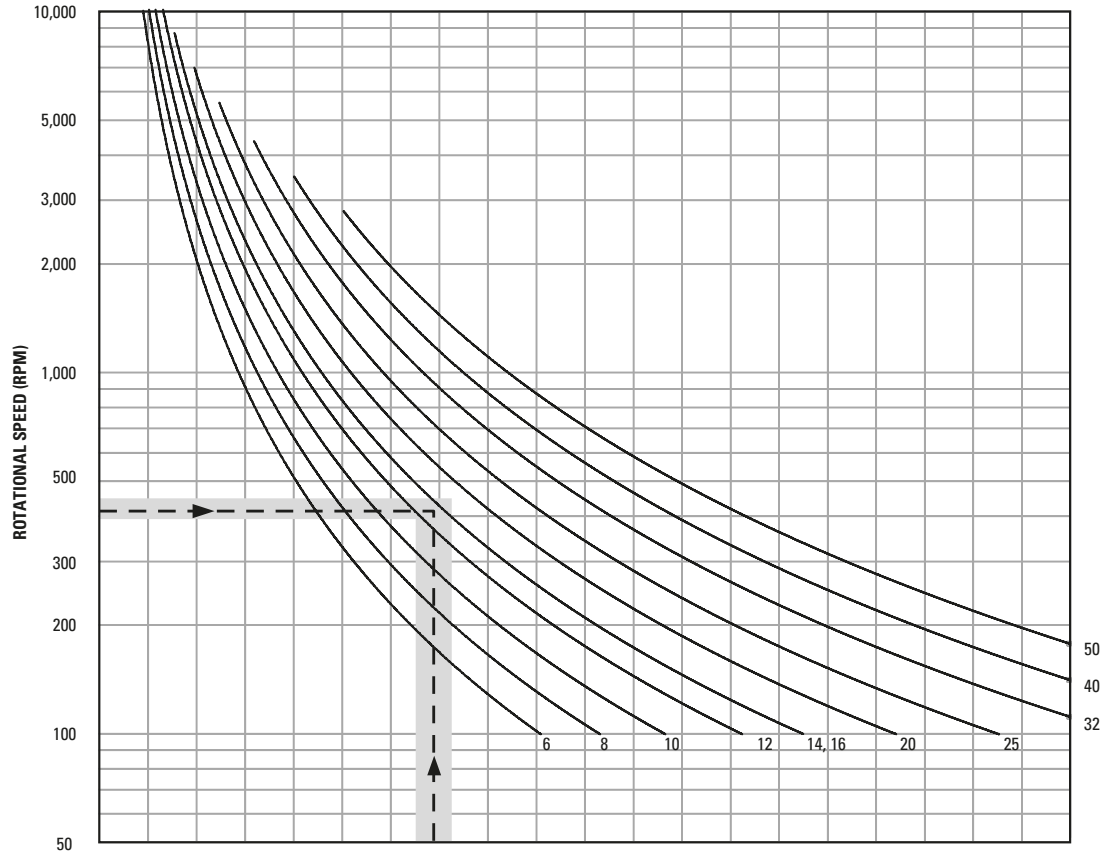

END SUPPORT TYPE

Support Type	Lead (in)	6	12	18	24	30	36	42	48	54	60	66	72	78	84	90	96	102	108	114	120
A: One end fixed, other end free	Inches	6	12	18	24	30	36	42	48	54	60	66	72	78	84	90	96	102	108	114	120
	mm	152	304	457	609	762	914	1066	1219	1371	1524	1676	1828	1981	2133	2286	2438	2590	2743	2895	3048
B: Both ends supported	Inches	10	20	30	40	50	60	70	80	90	100	110	120	130	140	150	160	170	180	190	200
	mm	254	508	762	1016	1270	1524	1778	2032	2286	2540	2794	3048	3302	3556	3810	4064	4318	4572	4826	5080
C: One end fixed, other end supported	Inches	12	24	36	48	61	73	85	97	109	121	133	145	158	170	182	194	206	218	230	242
	mm	304	609	914	1219	1549	1854	2159	2463	2768	3073	3378	3683	4013	4318	4622	4927	5232	5537	5842	6146
D: Both ends fixed	Inches	15	30	45	60	75	90	105	119	134	149	164	179	194	209	224	239	254	269	284	298
	mm	381	762	1143	1524	1905	2286	2667	3022	3403	3784	4165	4546	4927	5308	5689	6070	6451	6832	7213	7594

Ball Screw Engineering

Compression Load vs. Length for Designated Ball Screws

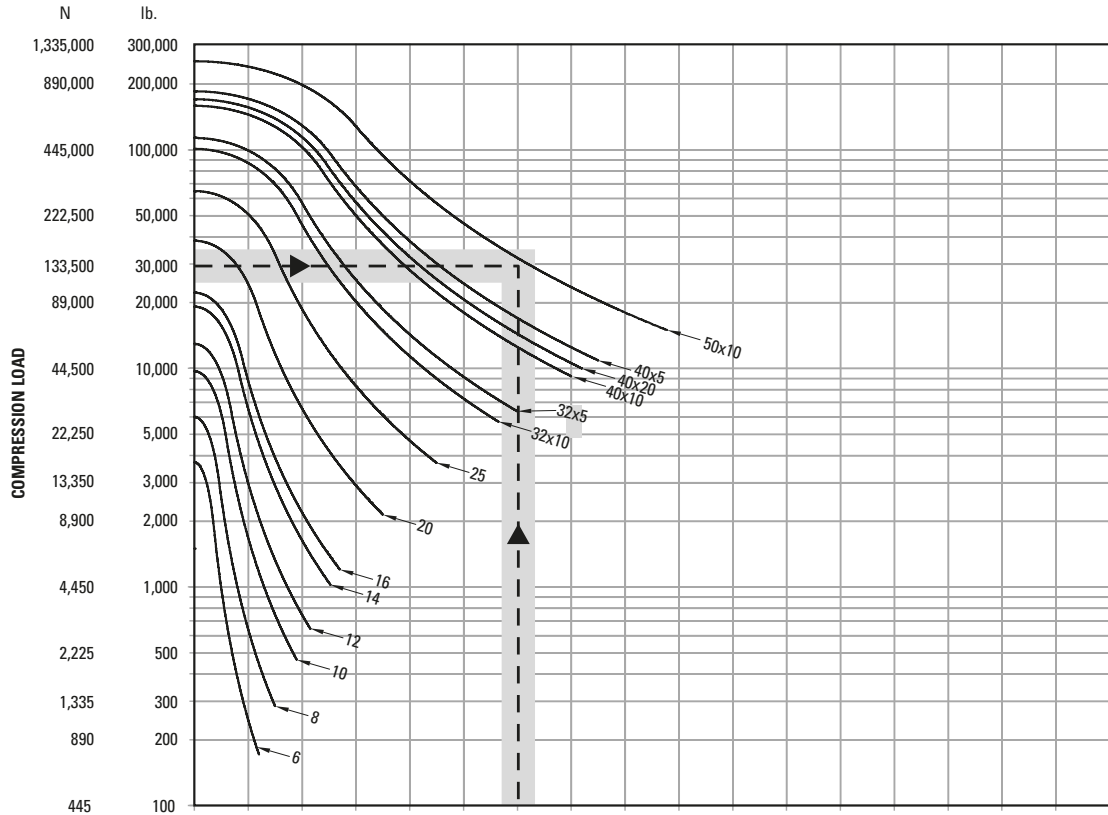

END SUPPORT TYPE

Support Type	Diagram	5	10	15	20	25	30	35	40	45	50	55	60	65	70	75	80	85
A	One end fixed, other end free	127	254	381	508	635	762	889	1016	1143	1270	1397	1524	1651	1778	1905	2032	2159
B	Both ends supported	254	508	762	1016	1270	1524	1778	2032	2286	2540	2794	3048	3302	3556	3810	4064	4318
C	One end fixed, other end supported	356	711	1067	1423	1779	2135	2491	2847	3203	3559	3915	4271	4627	4983	5339	5695	6051
D	Both ends fixed	508	1016	1524	2032	2540	3048	3556	4064	4572	5080	5588	6096	6604	7112	7620	8128	8636

Screw Accuracy – Permissible Travel Variation

Type P – Positioning Ball Screws

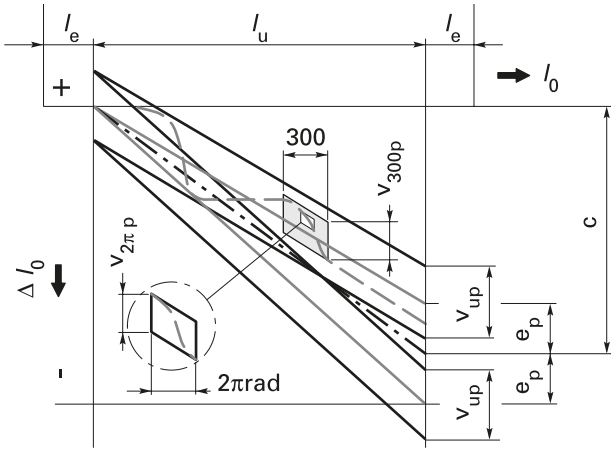

l_e = Axial thread length

l_u = Useful travel

l_o = Overrun = Table 2

Type T – Transport Ball Screws

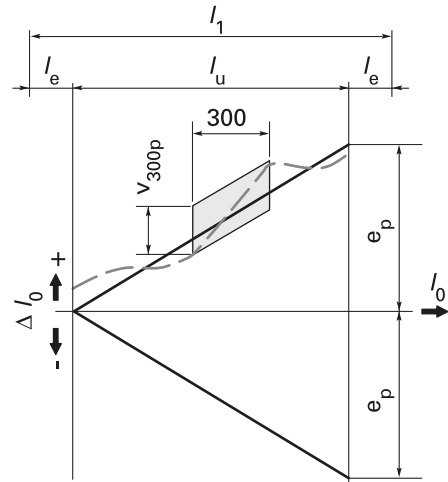

l_0 = Nominal distance

Δl_0 = Travel deviation

Lead Accuracy

		P3	P5	T7
v_{300p}	Permissible travel variance over 300 mm	Table 1	Table 1	Table 1
$v_{2\pi p}$	Permissible travel variance over 2π travel	Table 1	Table 1	-
c	Travel compensation	-0.01/1000	0	0
e_p	Limit deviations for useful distance l_u	Table 3	Table 3	$\pm \frac{l_u}{300} \cdot v_{300p}$
v_{up}	Permissible travel variance over useful travel l_u	Table 3	Table 3	-

Table 1

	Tolerance Class				
	1	3	4	5	7
v_{300p} [μm]	6	12	18	23	52
$v_{2\pi p}$ [μm]	4	6	7	8	12

Table 2

	Ph [mm]	Tolerance Class				
		≤ 2.5	≤ 5	≤ 10	≤ 20	> 20
Nominal lead						
Lead error	le [mm]	10	20	40	60	100

Table 3

	l_u [mm]		Tolerance Class																		
			>	0	315	400	500	630	800	1000	1250	1600	2000	2500	3150	4000	5000	6300	8000	10000	12500
Tolerance class	1	e_p	\leq	6	7	8	9	10	11	13	15	18	22	26	32	39	48	60	76	94	115
		v_{up}		6	6	7	7	8	9	10	11	13	15	17	21	27	33	40	50	61	76
	3	e_p		12	13	15	16	18	21	24	29	35	41	50	62	76	92	115	140	175	220
		v_{up}		12	12	13	14	16	17	19	22	25	29	34	41	49	61	75	92	113	140
	4	e_p		18	18	20	22	25	28	33	39	46	55	68	84	102	125	159	199	240	290
		v_{up}		18	19	20	21	23	26	29	33	38	44	52	56	68	83	101	124	152	189
	5	e_p		23	25	27	32	36	40	47	55	65	78	96	115	140	170	210	270	330	410
		v_{up}		23	25	26	29	31	34	39	44	51	59	69	82	99	119	142	174	213	265

Glossary and Formulas

Accuracy

A measurement of precision. Perfect accuracy, for example, means advancing a ball nut 25 mm from any point on a screw will always require the exact same number of revolutions.

Axial Lash / Backlash

The axial-free motion between the ball nut and ball screw; a measure of system stiffness and repeatability.

Column Load / Compression Load

Load that would tend to compress or buckle the ball screw shaft.

Dynamic Load Rating

Maximum load that a ball bearing screw assembly can maintain for 1 million revolutions (Metric Series).

Lead

The axial distance a screw travels during one revolution.

Lead Error

The amount of positional error per 300 mm (Metric Series) that is inherent in linear motion on ball screws.

Load/Life Rating

The usable life of a ball bearing screw assembly measured in revolutions under a specific load. The revolutions that 90% of a group of ball bearing screws will complete, or exceed, before the first evidence of fatigue develops.

Repeatability

A measure of constancy that is directly related to axial backlash. Higher backlash equates to lower repeatability and may be corrected by preloading the ball nut if required.

Static Load

Static load is the maximum non-operating load capacity above which brinelling of the ball track occurs.

Formulas

Equivalent Load	$F_{eq} [N] = \left(\sum_{i=1}^n F_i^3 \times \frac{n_i}{n_{eq}} \times \frac{q_i}{100} \right)^{1/3}$	Power	$P_d [W] = \frac{F_{eq} \times P \times n}{5.398 \times 10^4}$
Equivalent Speed	$n_{eq} [rpm] = \sum_{i=1}^n n_i \times \frac{q_i}{100}$	Critical Screw Speed	$n_s [rpm] = S \times C_{S_1} \times 1.2 \times 10^6 \times \frac{d_r}{L^2}$
Life	$L_{10} [Rot] = \left(\frac{C_{am}}{F_{eq}} \right)^3 \times 10^6$	Critical Nut Speed	$DN = d_0 n < 140,000$
Torque	$T [Nm] = 1.77 \times 10^{-4} \times F_{eq} \times P$	Permissible Compression Load	$F_s [N] = S \times C_{S_2} \times \frac{9.687}{L^2} \times 10^4 \times \frac{d_r^4}{L^2}$

q = Duration [%]

C_{am} = Dynamic Load [N]

P = Lead [mm]

C_s = End Fixity Factor (see table on the right)



S = Safety Factor (0.8 recommended)

d_0 = Nominal Diameter [mm]

d_r = Root Diameter [mm]

L = Max. Unsupported Length [mm]

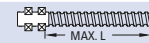
n = Rotational Speed of Screw [RPM]

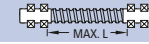
End Support		C_{S_1}	C_{S_2}
A		0.36	0.25
B		1.00	1.00
C		1.47	2.00
D		2.23	4.00

USA, CANADA and MEXICO

Thomson Customer Support
203A West Rock Road
Radford, VA 24141, USA
Phone: 1-540-633-3549
Fax: 1-540-633-0294
E-mail: thomson@thomsonlinear.com
Literature: literature.thomsonlinear.com



Thomson Marengo, IL USA

ISO 9001 certified, 88,000 sq. ft. facility manufacturing Linear Actuators, Ball Screws, Linear Bearings & Shafting, and Step Motors. Founded in 1967, currently with 220 employees.

Thomson Tijuana, Mexico

Engineering and manufacturing Linear Systems, Linear Bearings and Shafting and FSI ball screws, Custom Systems since 1998, currently with 220 employees in a 156,000 sq. ft facility. ISO 9001:2000, QS 9000 certified.

www.thomsonlinear.com

Metric_Precision_Rolled_Ball_Screws_BREN-0021-02A 20161212KB
Errors and technical alterations reserved. It is the responsibility of the product user to determine the suitability of this product for a specific application. All trademarks property of their respective owners. ©2016 Thomson Industries, Inc.

Linear Motion. Optimized.™