

Miniature Metric Ball Screws

Higher Load Capacity in a Smaller Package
for Laboratory, Medical and Mechatronic Applications

Miniature Metric Ball Screws

Thomson's line of miniature metric ball screws delivers smooth and quiet operation and best-in-class load capacity while providing ideal solutions for laboratory, medical and mechatronic applications. The improved load density of the miniature ball screw assemblies and availability of a wide range of diameters and leads create a truly flexible component solution. Ball nuts are precision manufactured to operate efficiently, quietly and smoothly. Thomson's state-of-the-art production facility and world-class supply chain ensure consistent product performance and industry leading delivery.

Better Load Capacity in a Smaller Package

- Design maximizes load capacity by optimizing return system
- Quiet and smooth performance
- Enables flexible ball nut mounting configurations and rapid prototyping
- Double the capacity of competition in most sizes

Improved Value

- Precision-rolled screws to T7 accuracy class standard
- State-of-the-art manufacturing provides lower cost and improved performance
- Higher load capacity equates to longer life

Genuine Thomson Quality and Innovation

- Expanding the brand with the greatest product breadth
- Proprietary thread form and processing equal quality and performance
- Expert technical and application support

The Design Challenge

The challenge for Thomson's engineers was to optimize the design of the ball nut. The solution was the unique multiliner return system that provides smoother operation and, as illustrated in the 12 × 2 example below, more load capacity.

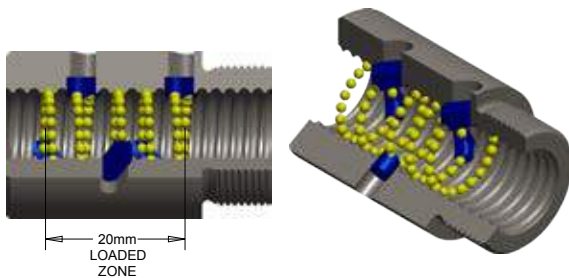

Typical Return System – Single Liner

- Fixed position secured by press or adhesive
- Does not allow full ball complement
- 5 circuits, 105 balls, 4.7 kN static capacity

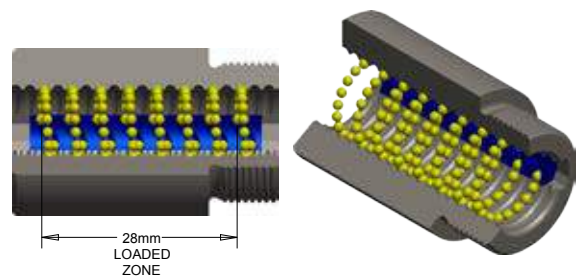

Thomson Multiliner Return System

- Floats axially to compensate for misalignment
- Maximizes number of circuits and loaded balls
- 8 circuits, 168 balls, 7.6 kN static capacity

Product Overview

Standard Configuration

- Screw diameters from 6 to 14 mm
- Screw lengths up to 3000 mm
- Ball nuts with threaded (TSI), flanged (FSI) or round (RSI) mounting interface
- Carbon steel construction
- Internal ball return system
- Performance repeatability (0.05 mm backlash)
- ± 52 µm / 300 mm lead accuracy (T7)

Optional Configurations Available

- Stainless steel construction
- Custom coatings available (thin dense chrome)
- ± 23 µm / 300 mm lead accuracy (T5 / P5)
- Reduced backlash (0.0125 mm)



TSI Style Ball Nut



FSI Style Ball Nut



RSI Style Ball Nut

How to Order

This ordering key provides a quick overview of the FSI, TSI and RSI Style versions available. To explore additional technical resources and options, contact Thomson customer support.

Ordering Key																	
1	2	3	4	5	6	7	8	9	10	11	12	13					
RM	12	02	Z2	-	xxxx	-	F	L	X	-	BK	S	-	K	X	-	
1. Nut Configuration RM = RH, Metric		3. Lead Code 02 = 2 mm 02.5 = 2.5 mm 03 = 3 mm 04 = 4 mm 05 = 5 mm			6. Nut interface F = Flanged nut (FSI) style T = Threaded nut (TSI) style R = Round nut (RSI) style with keyway			9/11. Left/Right Side Configuration X = Cut to length K = Machine to print BK = Base mount w/Drive BK1 = Base mount w/o Drive BF = Floating base mount w/Drive BF1 = Floating base mount w/o Drive FK = Flange mount w/Drive FK1 = Flange mount w/o Drive FF = Floating flange mount w/Drive FF1 = Floating flange mount w/o Drive MK = Motor mount					10/12. Left/Right Bearing Support X = No Support S = Support BK, etc.				
2. Diameter 06 = ø 6 mm 08 = ø 8 mm 10 = ø 10 mm 12 = ø 12 mm 14 = ø 14 mm		4. Backlash Z2 = Standard backlash (see Technical Specifications) Z3 = Minimum backlash (see Technical Specifications)			7. Nut Direction R = Nut faces right end L = Nut faces left end			8. Wipers X = No wipers W = Plastic wipers (optional – requires custom nut)					13. Custom Modifier Blank = Standard M = Custom (1) Custom only, contact customer support.				
		5. Overall Length xxxx.xx = Length (mm)															
<p>Code Example: RM1202Z2-271.5-FLX-BKS-KX</p> <p>This describes a standard lashed Ø12 x 2 mm FSI ball screw assembly that is 271.5 mm in overall length with a BK driven bearing support on the left side and custom specified machining on the right side without bearing support. The flange faces the left side with the BK bearing support.</p> <p>NOTE: Not all bearing supports are available in all sizes. See catalog or contact customer support for available combinations.</p>																	

Miniature Metric Rolled Ball Screws – General Specifications



Features and Benefits

- Leads from 6 to 14 mm
- Internal ball return system
- Cost-effective and space-saving solution
- Flexible solution for non-standard mounting
- Available in two standard backlash classes (Z2 and Z3)

Performance Specifications

Nominal Diameter	Lead	Ball Screw P/N	Performance Data					
			Dynamic Load Capacity ⁽¹⁾ (C _{dm})		Static Load Capacity (C ₀)		Max. Axial Backlash (Z2/Z3)	Lead Accuracy
			[kN]	[lbs]	[kN]	[lbs]	[mm]	[µm/300 mm]
6	2	190-9684	1.1	256	1.9	415	0.05 / 0.0125	± 52
8	2	190-9685	1.7	379	2.6	578	0.05 / 0.0125	± 52
8	2.5	190-9686	2.3	506	3.6	807	0.05 / 0.0125	± 52
8	3	190-9687	2.0	441	2.8	625	0.05 / 0.0125	± 52
10	2	190-9680	2.0	440	3.4	769	0.05 / 0.0125	± 52
10	3	190-9681	4.8	1076	8.6	1941	0.05 / 0.0125	± 52
10	4	190-9688	4.2	938	7.4	1658	0.05 / 0.0125	± 52
10	10	190-9689	2.9	659	5.2	1176	0.05 / 0.0125	± 52
12	2	190-9690	5.6	1258	13.1	2950	0.05 / 0.0125	± 52
12	3	190-9691	6.9	1560	14.7	3313	0.05 / 0.0125	± 52
12	4	190-9696	6.4	1436	13.0	2913	0.05 / 0.0125	± 52
12	5	190-9697	4.5	1016	9.2	2078	0.05 / 0.0125	± 52
14	3	190-9692	4.8	1080	10.4	2343	0.05 / 0.0125	± 52

Dimensional Specifications

Nominal Diameter	Lead	Screw Specifications						Nut Specifications	
		Major Diameter		Minor Diameter		Max. Length	Weight	Number of Circuits	Ball Diameter
		[mm]	[in]	[mm]	[in]	[mm]	[kg/m]		[mm]
6	2	5.9	0.233	4.9	0.194	1000	0.22	8	1.000
8	2	7.8	0.308	6.3	0.249	1500	0.38	5	1.588
8	2.5	7.8	0.308	6.3	0.249	1500	0.38	7	1.588
8	3	7.7	0.304	5.9	0.234	1500	0.37	3	1.984
10	2	9.8	0.386	8.3	0.328	1900	0.59	5	1.588
10	3	9.7	0.383	8.0	0.313	1900	0.58	7	1.984
10	4	9.7	0.383	7.9	0.313	1900	0.58	6	1.984
10	10	9.7	0.383	7.9	0.313	1900	0.58	2 × 1.8	1.984
12	2	11.8	0.465	10.3	0.407	1900	0.86	8	1.588
12	3	11.7	0.462	9.9	0.391	1900	0.85	9	1.984
12	4	11.6	0.457	9.7	0.382	3000	0.85	7	1.984
12	5	11.5	0.453	10.1	0.398	3000	0.85	5	1.984
14	3	13.7	0.540	12.0	0.471	1900	1.16	5	1.984

(1) Based on 1 million revolutions.

FSI Style Ball Nuts – Technical Specifications

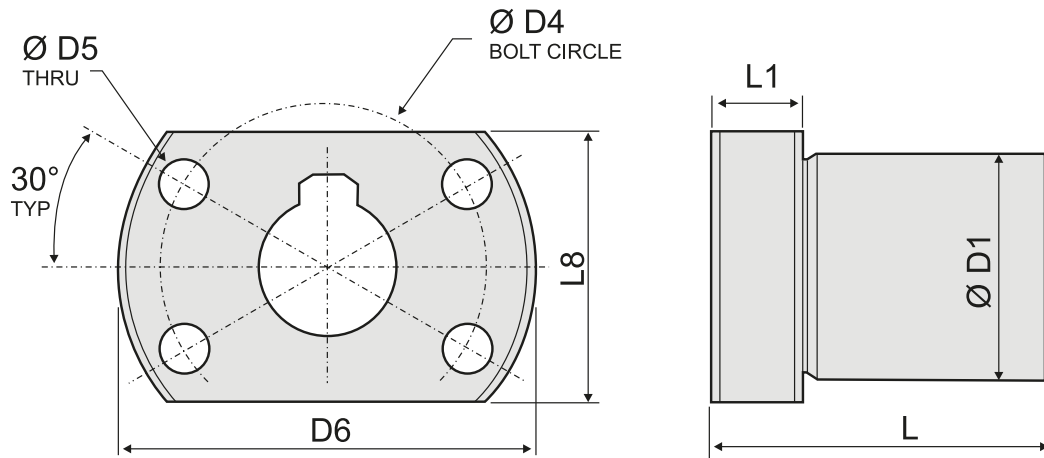

Dimensional Specifications

Nominal Diameter	Lead	Ball Nut Length (L)	Ball Nut P/N	Dimensions					
				D1 (g6)	D4	D5	D6	L1	L8
[mm]	[mm]	[mm]		[mm]	[mm]	[mm]	[mm]	[mm]	[mm]
6	2	22	8102-448-035	12	18	3.4	24	4	16
8	2	24	8103-448-036	16	22	3.4	28	6	19
8	2.5	24	8103-448-037	16	22	3.4	28	6	19
8	3	25	8103-448-038	16	22	3.4	28	6	19
10	2	22	8103-448-039	18	28	4.5	36	6	22
10	3	29	8103-448-040	18	28	4.5	36	6	22
10	4	35	8103-448-041	18	28	4.5	36	6	22
10	10	35	8103-448-042	23	30.5	4.5	38	6	24
12	2	40	8105-448-043	20	29	4.5	37	8	24
12	3	40	8105-448-044	20	29	4.5	37	8	24
12	4	38	8105-448-045	20	29	4.5	37	8	24
12	5	37	8105-448-046	20	29	4.5	37	8	24
14	3	35	8105-448-047	24	36	5.5	45	8	28

TSI Style Ball Nuts – Technical Specifications

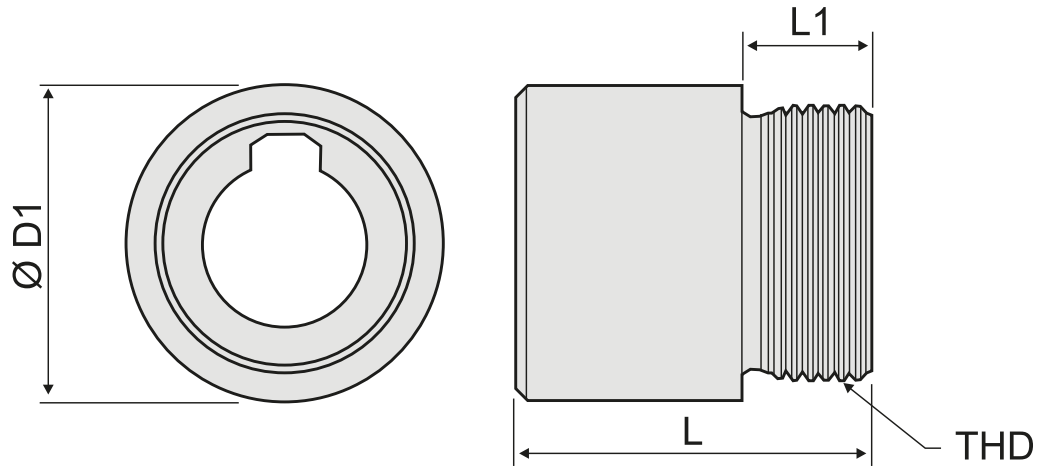

Dimensional Specifications

Nominal Diameter	Lead	Ball Nut Length (L)	Ball Nut P/N	Dimensions		
				D1 (0/-0.1)	THD	L1
[mm]	[mm]	[mm]		[mm]		[mm]
6	2	22	8102-448-025	16	M12 × 1	8
8	2	24	8103-448-026	18	M15 × 1	8
8	2.5	24	8103-448-027	18	M15 × 1	8
8	3	25	8103-448-028	18	M16 × 1	8
10	2	22	8103-448-022	19.5	M17 × 1	8
10	3	29	8103-448-023	21	M18 × 1	9
10	4	35	8103-448-029	21	M18 × 1	9
10	10	35	8103-448-030	23	M18 × 1	9
12	2	40	8105-448-031	24	M20 × 1	10
12	3	40	8105-448-032	26	M20 × 1	10
12	4	38	8105-448-034	25	M20 × 1	10
12	5	37	8105-448-024	24	M20 × 1	10
14	3	35	8105-448-033	30	M24 × 1.5	9

RSI Style Ball Nuts – Technical Specifications

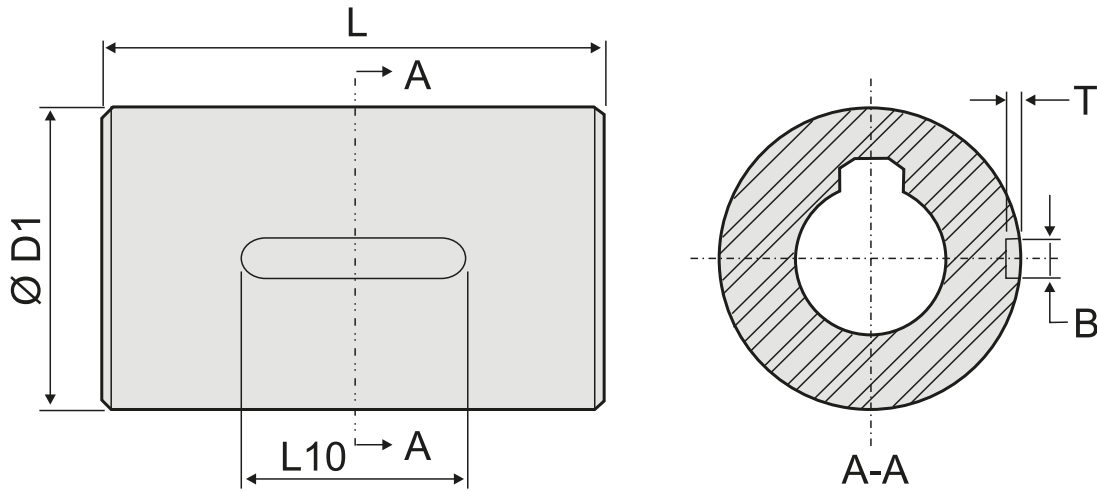

Dimensional Specifications

Nominal Diameter	Lead	Ball Nut Length (L)	Ball Nut P/N	Dimensions		
				D1 (g6)	B × T (P9)	L10
[mm]	[mm]	[mm]		[mm]	[mm]	
6	2	22	8102-448-048	16	2 × 1.2	10
8	2	24	8103-448-049	18	3 × 2	13
8	2.5	24	8103-448-050	18	3 × 2	13
8	3	25	8103-448-051	18	3 × 2	13
10	2	22	8103-448-052	19.5	3 × 2	13
10	3	29	8103-448-053	21	3 × 2	13
10	4	35	8103-448-054	21	3 × 2	13
10	10	26	8103-448-055	23	3 × 2	13
12	2	40	8105-448-056	24	3 × 2	18
12	3	40	8105-448-057	26	3 × 2	18
12	4	38	8105-448-058	26	3 × 2	18
12	5	37	8105-448-059	26	3 × 2	18
14	3	35	8105-448-060	30	4 × 2.5	19

USA, CANADA and MEXICO

Thomson
203A West Rock Road
Radford, VA 24141, USA
Phone: 1-540-633-3549
Fax: 1-540-633-0294
E-mail: thomson@thomsonlinear.com
Literature: literature.thomsonlinear.com

EUROPE

United Kingdom

Thomson
Office 9, The Barns
Caddsdow Business Park
Bideford
Devon, EX39 3BT
Phone: +44 (0) 1271 334 500
E-mail: sales.uk@thomsonlinear.com

Germany

Thomson
Nürtinger Straße 70
72649 Wolfschlügen
Phone: +49 (0) 7022 504 0
Fax: +49 (0) 7022 504 405
E-mail: sales.germany@thomsonlinear.com

France

Thomson
Phone: +33 (0) 243 50 03 30
Fax: +33 (0) 243 50 03 39
E-mail: sales.france@thomsonlinear.com

Italy

Thomson
Largo Brughetti
20030 Bovisio Masciago
Phone: +39 0362 594260
Fax: +39 0362 594263
E-mail: sales.italy@thomsonlinear.com

Spain

Thomson
E-mail: sales.esm@thomsonlinear.com

Sweden

Thomson
Estridsväg 10
29109 Kristianstad
Phone: +46 (0) 44 24 67 00
Fax: +46 (0) 44 24 40 85
E-mail: sales.scandinavia@thomsonlinear.com

ASIA

Asia Pacific

Thomson
E-mail: sales.apac@thomsonlinear.com

China

Thomson
Rm 2205, Scitech Tower
22 Jianguomen Wai Street
Beijing 100004
Phone: +86 400 6661 802
Fax: +86 10 6515 0263
E-mail: sales.china@thomsonlinear.com

India

Thomson
c/o Fluke Technologies Pvt. Ltd.
#424, Deodhar Center,
Marol Maroshi Road,
Andheri – E, Mumbai – 400059 India
Phone: +91 22 29207641
E-mail: sales.india@thomsonlinear.com

Japan

Thomson
Minami-Kaneden 2-12-23, Suita
Osaka 564-0044 Japan
Phone: +81-6-6386-8001
Fax: +81-6-6386-5022
E-mail: csjapan@scgap.com

Korea

Thomson
F7 Ilsong Bldg, 157-37
Samsung-dong, Kangnam-gu,
Seoul, Korea (135-090)
Phone: +82 2 6917 5049
Fax: +82 2 528 1456
E-mail: sales.korea@thomsonlinear.com

SOUTH AMERICA

Brazil

Thomson
Av. Tamboré, 1077
Barueri, SP – 06460-000
Phone: +55 (11) 3616-0191
Fax: +55 (11) 3611-1982
E-mail: sales.brasil@thomsonlinear.com