

Fractional

Double Anchor Fasteners

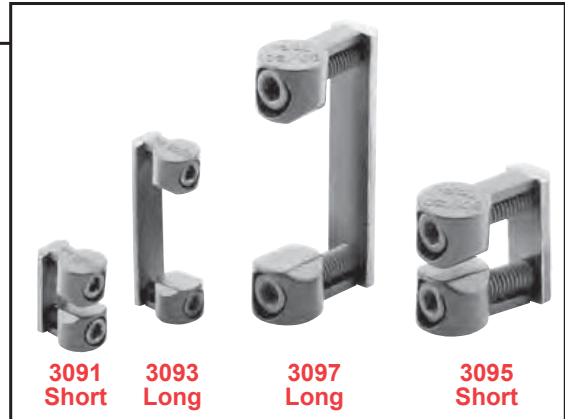

- One of 80/20®'s strongest fastening options
- Allows infinite positioning along a T-slotted profile
- Provides a vibration-proof, clean, flush connection where space restrictions apply
- Creates 90° connections where T-slots are in alignment
- Profile must have T-slots opposite each other
- Short assemblies mount across the 1.0" dimension for 10 Series and 1.5" dimension for 15 Series
- Long assemblies mount across the 2.0" dimension for 10 Series and 3.0" dimension for 15 Series
- Refer to page 567 for counterbore machining specifications



Part No.	Finish	Bolt Assembly (Included)	Lbs.	Profile Compatibility
3090	Zinc Casting w/ Lacquer Finish	10-32 Short Assembly	.062	1010, 1003, 1004, 1020, 1030
3091	Zinc Casting w/ Black Finish	10-32 Short Assembly	.062	1010, 1003, 1004, 1020, 1030
3092	Zinc Casting w/ Lacquer Finish	10-32 Long Assembly	.080	1020, 2020, 2040
3093	Zinc Casting w/ Black Finish	10-32 Long Assembly	.080	1020, 2020, 2040
3094	Zinc Casting w/ Lacquer Finish	M5 Short Assembly	.062	1010, 1003, 1004, 1020, 1030
3096	Zinc Casting w/ Lacquer Finish	M5 Long Assembly	.080	1020, 2020, 2040
3098	Zinc Casting w/ Lacquer Finish	5/16-18 Short Assembly	.202	1515, 1515-Lite, 1503, 1504, 1530, 1530-Lite, 1545
3095	Zinc Casting w/ Black Finish	5/16-18 Short Assembly	.202	1515, 1515-Lite, 1503, 1504, 1530, 1530-Lite, 1545
3099	Zinc Casting w/ Lacquer Finish	5/16-18 Long Assembly	.263	1530, 1530-Lite, 3030, 3060
3097	Zinc Casting w/ Black Finish	5/16-18 Long Assembly	.263	1530, 1530-Lite, 3030, 3060
3100	Zinc Casting w/ Lacquer Finish	M8 Short Assembly	.202	1515, 1515-Lite, 1503, 1504, 1530, 1530-Lite, 1545
3102	Zinc Casting w/ Lacquer Finish	M8 Long Assembly	.263	1530, 1530-Lite, 3030, 3060

☒ = 10 Series Compatible Part

