

**80/20® Inc.**The *Industrial Erector Set®***THE STANDARD****Slide-In T-Nuts**

- Loads from the profile end only
- Made from 1215 carbon steel with bright and black zinc finishes
- Up to 36" standard T-nut lengths are available for customized T-nut hole configuration\*
- Refer to pages 249-259 for our full screw and bolt offering
- See page 563 for cut-to-length, Part No. 7212.

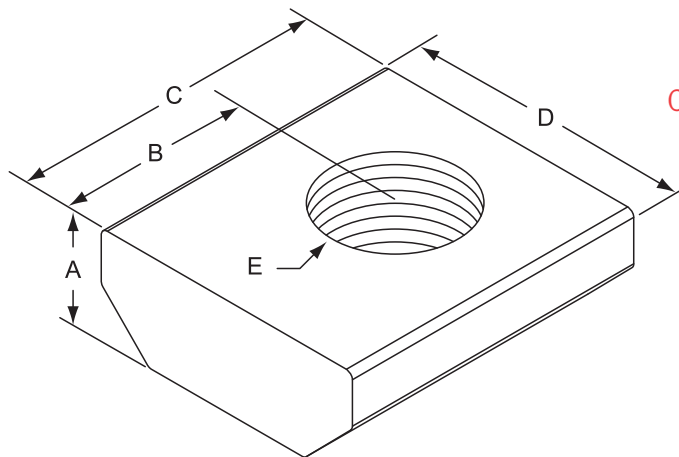
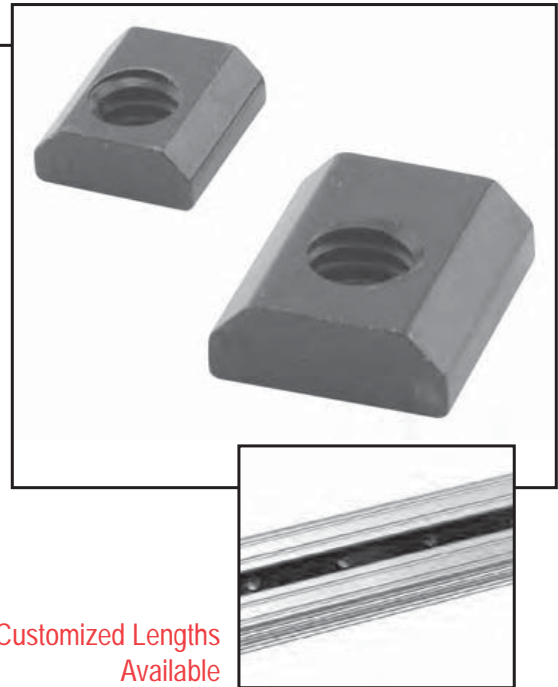

Customized Lengths Available

3

Part No.	A	B (Tap Location)	C	D	E (Thread)	Finish	Lbs.
3205 ☒	.171	.200	.490	.431	10-32	Black Zinc	.010
3204 ☒	.171	.200	.490	.431	1/4-20	Black Zinc	.010
3206 ☒	.171	.200	.490	.431	M5 x .80	Black Zinc	.010
3871 ☒	.171	.200	.490	.431	M5 x .80	Bright Zinc	.010
3873 ☒	.171	.200	.490	.431	M6 x 1.00	Bright Zinc	.010
8901 ☒	.171	Per your Drawing	Per your Drawing	.431	Per your Drawing	Per your Drawing	.230 / Ft.
8901-36 ☒	.171	N/A	36.000	.431	N/A	Black or Bright Zinc	.690
3201	.250	.281	.687	.625	10-32	Black Zinc	.020
3202	.250	.281	.687	.625	1/4-20	Black Zinc	.020
3203	.250	.281	.687	.625	5/16-18	Black Zinc	.020
3866	.250	.281	.687	.625	M6 x 1.00	Bright Zinc	.020
3703	.250	.281	.687	.625	5/16-18	Bright Zinc	.020
3868	.250	.281	.687	.625	M8 x 1.25	Bright Zinc	.020
8900	.250	Per your Drawing	Per your Drawing	.625	Per your Drawing	Per your Drawing	.460 / Ft.
8900-36	.250	N/A	36.000	.625	N/A	Black or Bright Zinc	1.308

☒ = 10 Series Compatible Part

\*Note: 80/20® can customize T-nut profiles to match your specific requirements; simply submit a sketch to 80/20® or your distributor.