

80/20[®] Inc.
 The *Industrial Erector Set[®]*
THE STANDARD

Aluminum Tube

- Drawn precision tube
- Stock length: 144" mill-finish (unanodized) and clear anodized finish
- See page 563 for cut-to-length services
- Tolerance: $+.003"$ / $-.002"$

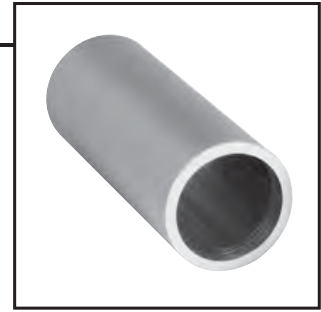
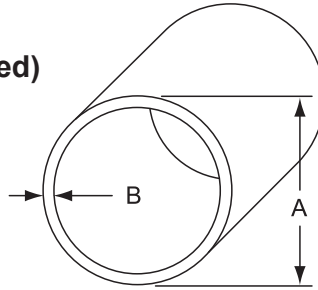

Part No.		A	B	Alloy	Cut-To-Length	
Clear Anodized	Mill-Finish				Part No.	Lbs. / Ft.
5035	5036	1.000	.125	6061-T6	7205	.405
5040	5041	1.500	.125	6061-T6	7210	.630
5045	5046	2.000	.125	6061-T6	7213	.930

Ground & Polished Steel Tube

- Ground and polished, drawn over mandrel (DOM) carbon steel
- Stock length: 145" unfinished (non-plated, non-oxidized)
- See page 563 for cut-to-length services
- Black oxide service available, call for details
- Tolerance: $+.003"$ / $-.002"$

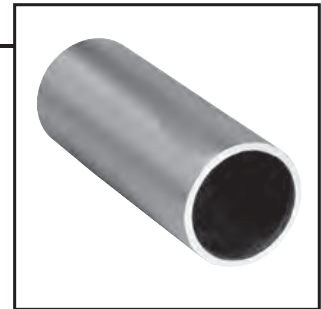
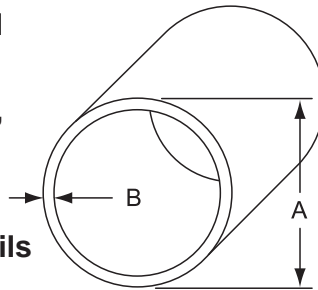

Part No.	A	B	Alloy	Cut-To-Length Part No.	Lbs. / Ft.
5005	1.000	.125	1020	7205	1.168
5015	1.500	.125	1020	7210	1.836
5025	2.000	.125	1020	7213	2.503

Turned, Ground and Polished Solid Carbon Steel



- Stock length: 145" unfinished (non-plated, non-oxidized)
- See page 563 for cut-to-length services
- Black oxide service available, call for details
- Tolerance: $+.003"$ / $-.002"$

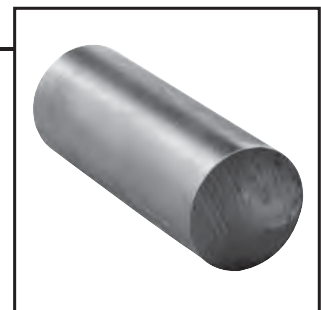
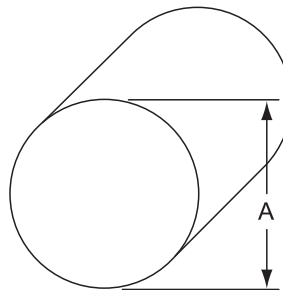

Part No.	A	Alloy	Cut-To-Length Part No.	Lbs. / Ft.
5010	1.000	1045	7205	2.670
5020	1.500	1045	7210	6.010
5030	2.000	1045	7213	10.680