



# WhisperTrak™ Electric Linear Actuators

Quiet, Versatile and Compact Actuators

[www.thomsonlinear.com](http://www.thomsonlinear.com)

**THOMSON**<sup>®</sup>  
*Linear Motion. Optimized.™*

## The Quiet, Versatile and Compact Alternative

Thomson WhisperTrak™ models are the quietest additions to our well-known electric linear actuator family. This actuator range sets the standard for medical, personal mobility, material handling, marine and structure automation applications. It is small, quiet, washdown-proof and created from the accumulated knowledge that Thomson has gathered from being the actuator industry leader for more than 50 years.



**Please visit:**  
[www.thomsonlinear.com/whispertrak](http://www.thomsonlinear.com/whispertrak)

- Technical Information
- Product Selector
- CAD Models
- Tech Tips Videos

## Features and Benefits

WhisperTrak™ actuators were designed to incorporate features that enable machine and equipment builders the greatest flexibility in their designs. A sleek and compact design, washdown protection and electronic limit switches are just some of the features offered. Combine those with a global sales and service organization, and the result is an optimal actuator for the applications it was built to serve.

### Exceptionally Quiet

WhisperTrak linear actuators boast a low sound level of less than 45 dBA, about the same as an average library. This quiet, consistent low sound level is conducive to personal mobility applications and provides unobtrusive linear motion in an elegant package.

### Permanent Sealing for Environmental Protection

WhisperTrak is rated for protection class IP67 and is able to operate in harsh conditions where it is exposed to washdown, rain, dust, or other particulate without the use of any additional cover.

### Compact and Compatible

The WhisperTrak linear actuator is one of the most compact actuators on the market and is pin-to-pin compatible with virtually all competitor actuators in this segment. This allows you to easily replace an existing actuator with the WhisperTrak and gain the space-saving benefits while reducing weight.

### Maintenance Free

WhisperTrak requires zero maintenance throughout the entire life of the actuator. The average life is 10,000 cycles (one full stroke back and forth) at the maximum load. Once properly installed, the actuator will provide trouble-free operation with zero maintenance, thereby reducing the total cost of ownership.

### Unique Options

The WhisperTrak linear actuator is unique in that it offers a compact machine footprint and robust features that are unavailable anywhere else. The electronic limit switches (ELS) and feedback options are available off the shelf and fit within the compact envelope of the standard model. Mounting options include standard (pictured) or rotated 90 degrees.

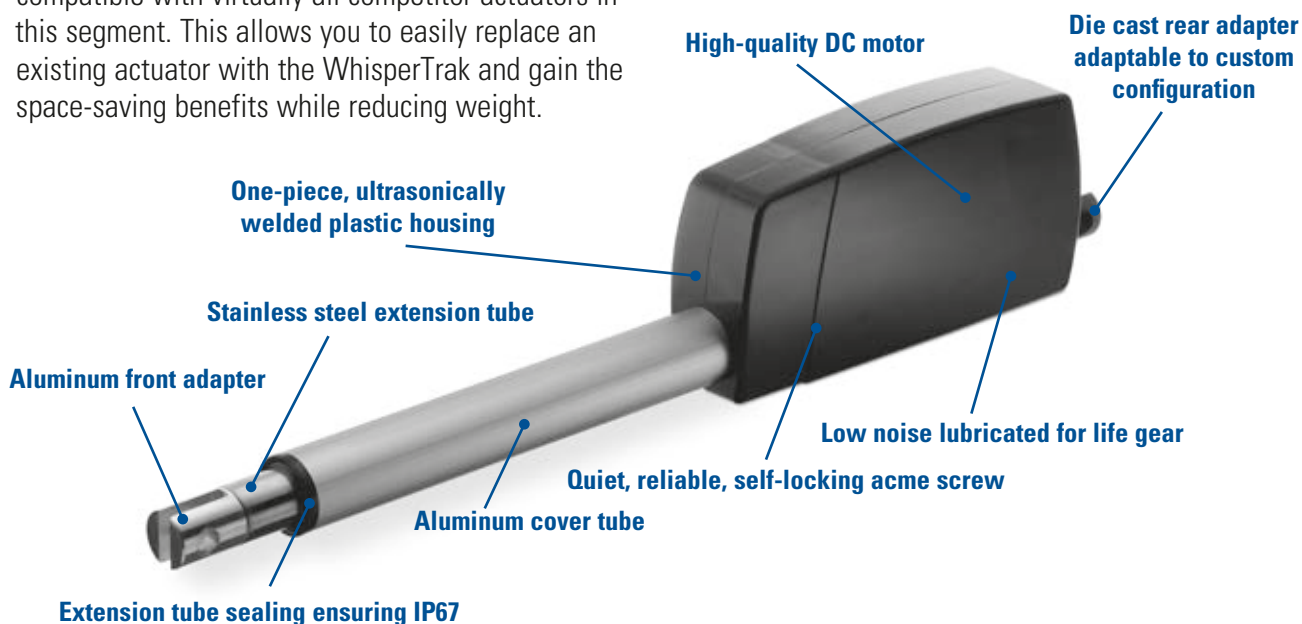

## Applications

Applications that require overall design flexibility with a small footprint, quiet operation or the ability to withstand harsh conditions can benefit from the compact envelope and one-piece housing of the Thomson WhisperTrak™.

### Patient Handling

For simple and safe mobility and handling, the WhisperTrak's lightweight, quiet design lends itself ideally to medical devices. Wheel chairs benefit from up to a dozen electrified movements.



### Structural Automation

Robustness and powerful, yet quiet, operation allows WhisperTrak to excel in residential and commercial automation applications.

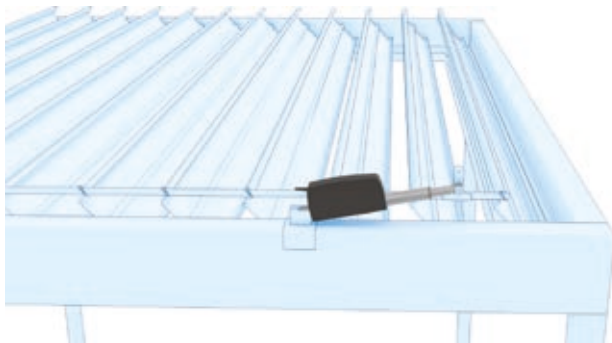

### Marine

Whispertrak's IP67 rating allows it to handle water spray in many marine automation applications.

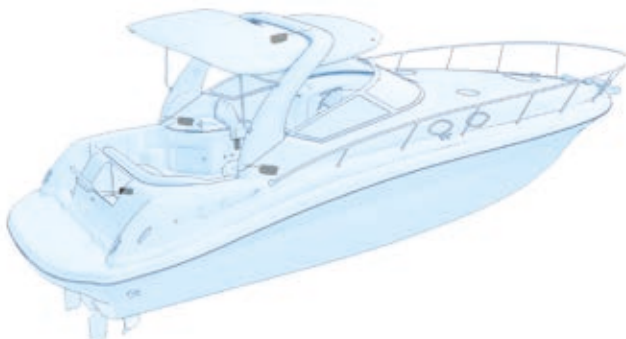

### Material Handling

WhisperTrak offers the benefits of a truly industrial linear actuator and combines them with a compact and easy-to-use design that complements the aesthetics of your factory equipment.

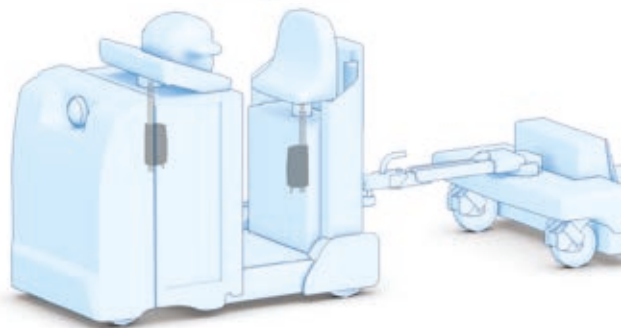
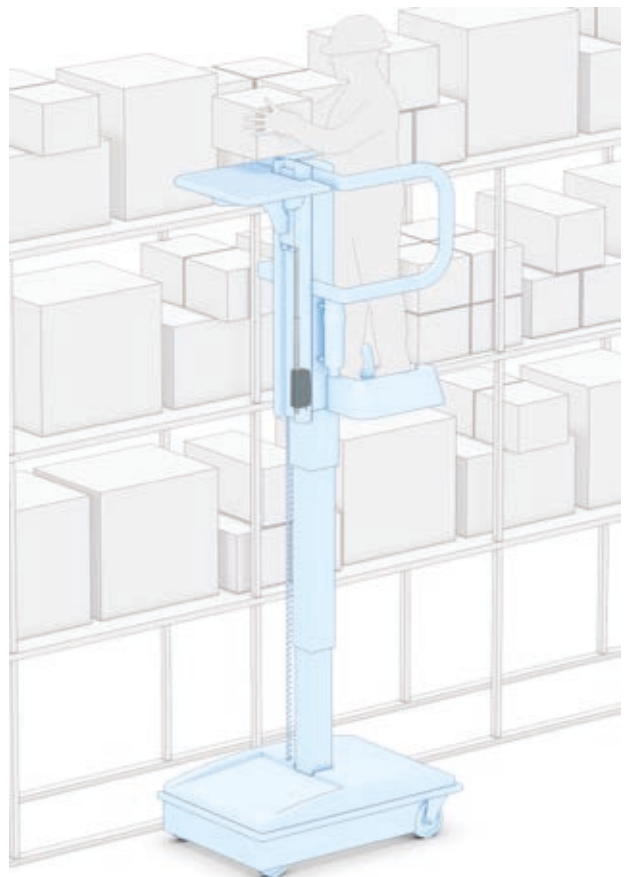

# Specifications

Technical Specification	Wxx02 (2000 N (450 lbs) Version)				Wxx04 (4000 N (900 lbs) Version)		
Voltage							
Input voltage [VDC]	12		24		12		24
Load							
Static load (Fx), maximum [N (lbs)]	2000 (450)				4000 (900)		
Dynamic load (Fx), maximum [N (lbs)]	2000 (450)				4000 (900)		
Stroke							
Stroke lengths, standard [cm (inch)]	10 (3.94), 20 (7.87), 30 (11.81), 40 (15.75), 50 (19.69)						
Speed							
Speed version	58A	54A	58A	54A	58A		58A
Speed, no load [mm/s (inch/s)]	5.8 (0.23)	11.0 (0.43)	5.8 (0.23)	11.0 (0.43)	5.8 (0.23)		5.8 (0.23)
Speed, rated load [mm/s (inch/s)]	4.0 (0.16)	8.0 (0.31)	4.0 (0.16)	8.0 (0.31)	4.0 (0.16)		4.0 (0.16)
Current							
Current draw @ rated max. load [A]	4.5	9.0	2.2	4.5	9.0		4.5
Current draw @ stall/in-rush [A]	14.0	21.0	8.0	11.0	21.0		11.0
General data							
End play, maximum [mm (inch)]	0.5 (0.020)						
Operating temperature limits [°C (°F)]	-25 to +40 (-13 to +104) <sup>(1)</sup>						
Duty cycle, maximum [%]	10						
On-time, maximum [s]	180	90	180	90	90		90
Life, average [cycles]	10 000						
Sound level [dBA]	< 45						
Lead screw type	acme						
Protection class	IP67						
Anti rotation mechanism <sup>(2)</sup>	yes						
Analog feedback output signal voltage [VDC]	0.5 - 4.5						
Analog feedback output signal linearity [%]	0.5						
Digital feedback input voltage [VDC]	3.8 - 24						
Digital feedback output resolution [pulses/mm]	10	5	10	5	10		10
Compliances	IEC 60601-1, CSA C22.2, AAMI ES60601-1 <sup>(3)</sup>						
Options							

- Electronic limit switches (ELS)<sup>(4)</sup>
- ELS + low level switching<sup>(1)(5)</sup>
- Analog or digital position feedback, with or without ELS
- Mounting adapters turned 90°

1) Thrust is reduced at lower temperatures for 2000 N (450 lbs) high speed (54A) and 4000 N (900 lbs) units with ELS + low level switching (option E), see diagram on page 7.

2) Prevents the extension tube from rotating if it is not fixed in the end.

3) 4 kN units greater than 30 cm of stroke are not ETL recognized. ETL certification available on N, E, P and D feedback options only.

4) Shuts off power at the end of stroke and all along the stroke at overload conditions. ELS is normally set for 120% of the rated dynamic maximum load.

5) Low level switching allows low level signals to control the actuator movement instead of having to switch the high amperage motor voltage.

# Dimensions

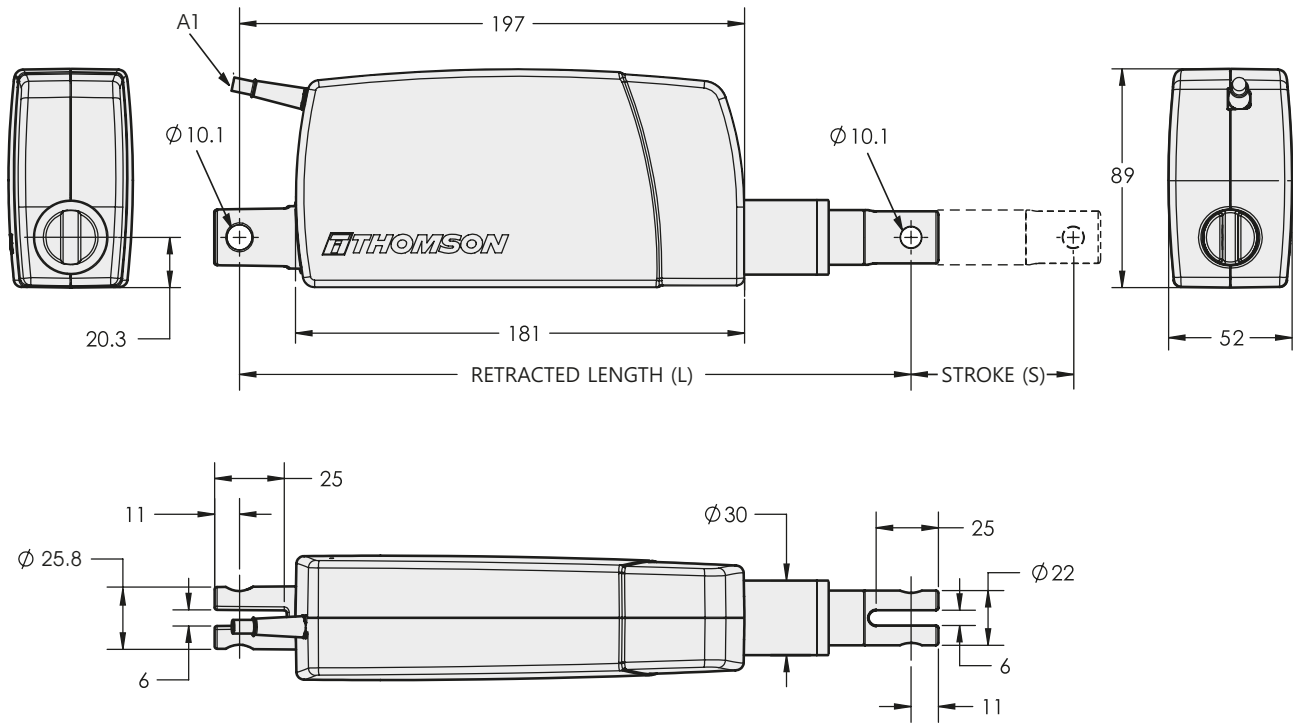

A1: Cable, see available cable lengths and types in the ordering key on page 8

Wxx02 (2000 N (450 lbs) Version)						
Stroke "S"	[mm (inch)]	100 (3.94)	200 (7.87)	300 (11.81)	400 (15.75)	500 (19.69)
Retracted Length "L"	[mm (inch)]	238 (9.37)	338 (13.31)	438 (17.24)	589 (23.19)	689 (27.13)
Weight	[kg (lbs)]	1.20 (2.65)	1.35 (2.98)	1.5 (3.31)	1.65 (3.64)	1.80 (3.97)

Wxx-04 (4000 N (900 lbs) Version)						
Stroke "S"	[mm (inch)]	100 (3.94)	200 (7.87)	300 (11.81)	400 (15.75)*	500 (19.69)*
Retracted Length "L"	[mm (inch)]	246 (9.69)	346 (13.62)	446 (17.56)	597 (23.50)	697 (27.44)
Weight	[kg (lbs)]	1.36 (3.00)	1.52 (3.35)	1.67 (3.68)	1.82 (4.01)	1.97 (4.34)

\* 4 kN units greater than 30 cm of stroke are not ETL recognized. ETL certification available on N, E, P and D feedback options only.

# Performance

Wxx02-58A - Load vs. Speed / Current  
(2000 N (450 lbs) Standard Speed Version)

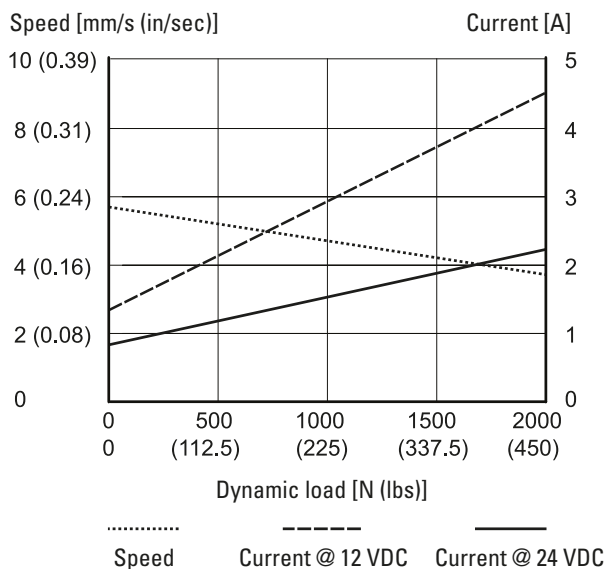

Wxx02-54A - Load vs. Speed / Current  
(2000 N (450 lbs) High Speed Version)

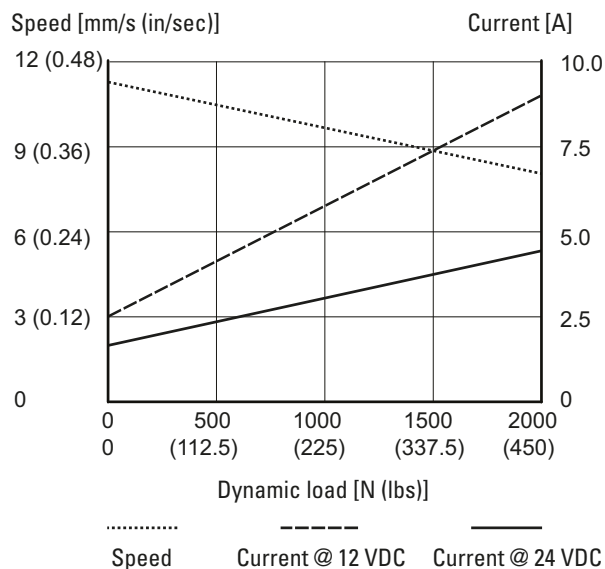

Wxx04-58A - Load vs. Speed / Current  
(4000 N (900 lbs) Version)

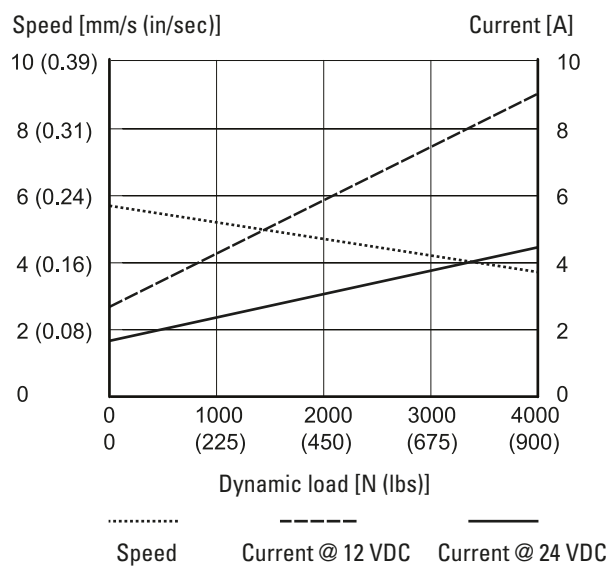

Load Capacity vs. Operating Temperature\*

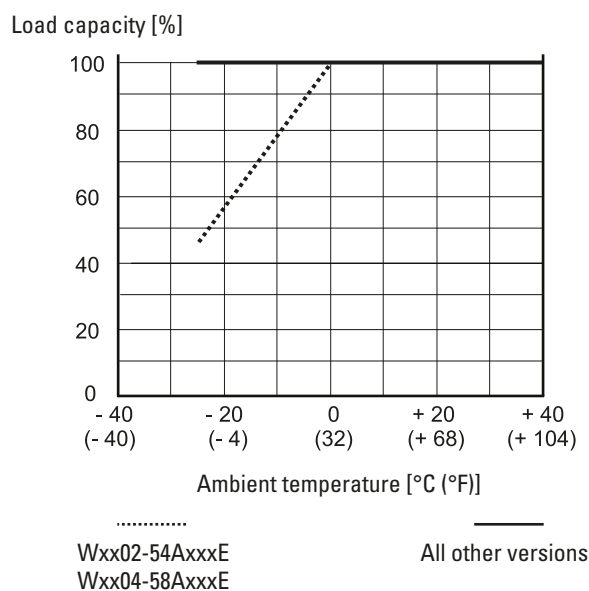

\* Most versions have the same load capacity within the permissible operating temperature limits. Two versions however (Wxx02-54AxxxE and Wxx04-58AxxxE) have a reduced capacity at lower temperatures. Also see page 11 regarding "Electronic Limit Switches + Low Level Switching (Option E)".

# Ordering Key

Ordering Key								
1	2	3	4	5	6	7	8	9
W12	02-	58A	10	-	N	A	1	B
<b>1. Model and input voltage</b>								
W12 = WhisperTrak, 12 VDC W24 = WhisperTrak, 24 VDC								
<b>2. Maximum dynamic force</b>								
02- = 2000 N (450 lbs) 04- = 4000 N (900 lbs)								
<b>3. Rated no load speed</b>								
58A = 5.8 mm/s (standard speed version) 54A = 11.0 mm/s (high speed version, only available for 2000 N version)								
<b>4. Maximum stroke length</b>								
10 = 100 mm 20 = 200 mm 30 = 300 mm 40 = 400 mm 50 = 500 mm								
<b>5. Retracted length</b>								
- = standard retracted length (see tables on page 6) L = retracted length for units with 100 - 300 (400 - 500) mm maximum stroke length = max. stroke + 140 (191) mm								
<b>6. Onboard control options (see page 9 for descriptions and page 10 for possible combinations of actuator type and control option)</b>								
N = standard - no electronic control (for use with Thomson DCG Control) X = electronic limit switches (ELS) E = ELS + low level switching P = analog position feedback D = digital feedback Y = ELS + digital feedback Z = ELS + analog position feedback Note: ETL certification available on N, E, P and D feedback options only.								
<b>7. Type, adapter position<sup>1</sup> and anti-rotation mechanism</b>								
A = anti-rotation, adapter holes in standard position M = anti-rotation, adapter holes turned 90°								
<b>8. Cable and Connector Options</b>								
1 = 1 meter long cable with flying leads (for customer supplied connectors) 3 = 2 meter long cable with Molex type connector, only possible with control options N and D (connector compatible with DCG control)								
<b>9. Enclosure color</b>								
B = black W = white								

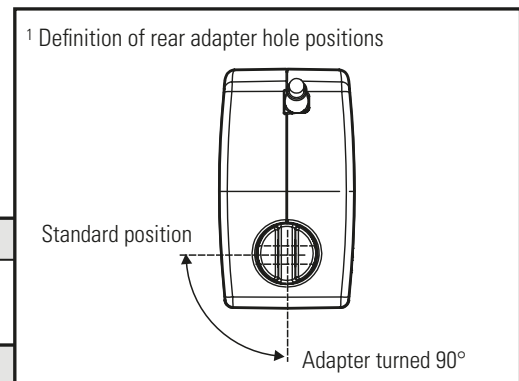

Whispertrak is warranted to be free from defects in materials and workmanship for a period of twelve (12) months from date of delivery. The application of this product is the responsibility of the buyer and Thomson makes no representation or warranty as to the suitability of the product for any particular use or purpose. Please go to [http://www.thomsonlinear.com/website/com/eng/support/terms\\_and\\_conditions.php](http://www.thomsonlinear.com/website/com/eng/support/terms_and_conditions.php) for a copy of the entire warranty for this product that is contained in our standard terms and conditions of sale.



## Onboard Control Option Combinations

Possible Combinations of Onboard Control Options and Actuator Types							
		Actuator Input Voltage, Max. Dynamic Force and Speed Version					
		12 VDC			24 VDC		
		2000 N		4000 N	2000 N		4000 N
Option Name	Code	Standard	High	Standard	Standard	High	Standard
Standard (for use with DCG control)	N				•	•	•
Electronic Limit Switches (ELS)	X	•			•	•	•
ELS + Low-Level Switching	E	•	•	•	•	•	•
Analog Position Feedback	P	•	•	•	•	•	•
Digital Feedback	D	•	•	•	•	•	•
ELS + Digital Feedback	Y	•			•	•	•
ELS + Analog Position Feedback	Z	•			•	•	•

### Actuators Without Low Level Switching

- By switching the polarity of the voltage to the motor, the extension tube will change direction.
- Make sure that the switch and the wiring can handle the maximum motor current.

### Actuators With Low-Level Switching

- The direction of the extension tube is controlled by switching the COM (common) output to the EXT (extend) or RET (retract) inputs.

### Actuators Without Electronic Limit Switches

- The actuator voltage must be switched off when reaching the ends of stroke or due to a mid-stroke overload to avoid causing damage to the actuator.

### Actuators With Electronic Limit Switches

- The actuator will automatically switch off when reaching the ends of stroke or a mid-stroke overload.

## Onboard Control Options

### Standard - No Electronic Control (Option N)

This option is to be selected when using the DCG controls. Without the DCG control, this option is only compatible with the 2kN standard speed (W2402-58A) actuator.

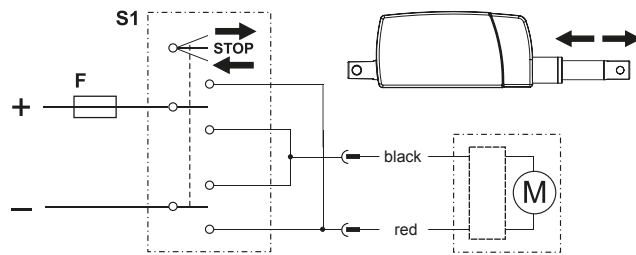

M = actuator motor, S1 = double pole double throw (DPDT) switch, F = fuse

- By switching the polarity of the voltage to the motor, the extension tube will change direction.
- Make sure that the switch and the wiring can handle the maximum motor current.
- The actuator voltage must be switched off when reaching the ends of stroke or due to a mid-stroke overload to avoid causing damage to the actuator.
- Always protect the actuator and the wiring by using a fuse between the actuator and the power source.

### Electronic Limit Switches (Option X)

The Electronic Limit Switches (ELS) option turns off power to the actuator at end of stroke or during a mid-stroke overload condition. This option has two wires going to the actuator, and the customer-provided switch must be capable of switching full load current. The acceptable voltage range for this option is 11 - 18 VDC. The actuator will run slightly slower at the same voltage than with options E or N.

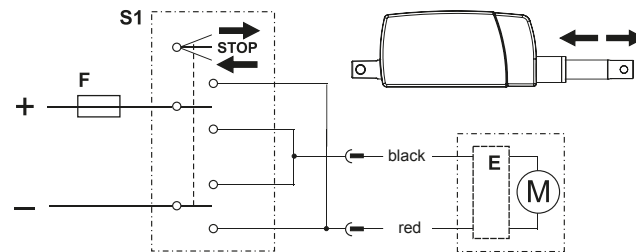

M = actuator motor, S1 = double pole double throw (DPDT) switch, F = fuse  
E = electronic limit switches

- By switching the polarity of the voltage to the motor, the extension tube will change direction.
- Make sure that the switch and the wiring can handle the maximum motor current.
- The actuator voltage must be switched off when reaching the ends of stroke or due to a mid-stroke overload to avoid causing damage to the actuator.
- Always protect the actuator and the wiring by using a fuse between the actuator and the power source.

## Onboard Control Options

### Electronic Limit Switches + Low-Level Switching (Option E)

This control automatically turns off power to the motor when current exceeds a preset threshold either at ends of stroke or due to a mid-stroke overload condition. This current threshold is directly related to thrust and can be set at the factory during assembly to independently control extend and retract travel. The default setting is rated dynamic load plus 20% nominal which means 2400 N nominal for the 2000 N model and 4800 N nominal for the 4000 N model. This option also utilizes on-board low-level switching that allows the travel to be controlled by low current signals rather than having to switch the motor current. This makes it possible to control the actuator by means of microprocessors, push buttons or relays not capable of switching the motor current. The acceptable voltage range for this option is 9 - 16 VDC. Two actuator versions with option E will also have a reduced load capacity at lower temperatures. They are Wxx02-54AxxxE (2000 N high speed version) and Wxx04-58AxxxE (4000 N version). Also see diagram "Load Capacity vs. Operating Temperature" on page 7.

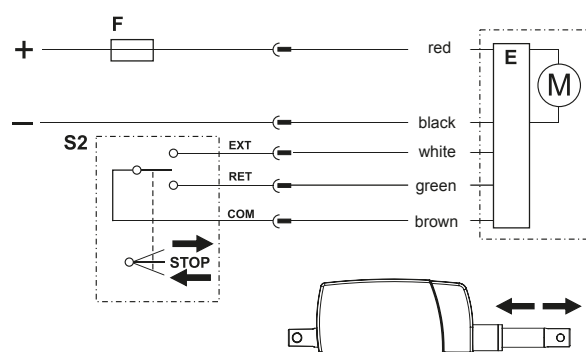

M = actuator motor, S2 = single pole double throw (SPDT) switch, F = fuse  
E = electronic limit switches

- E option is used when the customer provides the power supply but requires electronic limit switches or low-level switching.
- The direction of the extension tube is controlled by switching the COM (common) output to the EXT (extend) or RET (retract) inputs.
- The actuator will automatically switch off when reaching the ends of stroke or a mid-stroke overload.
- Always protect the actuator and the wiring by using a fuse between the actuator and the power source.

### Analog Position Feedback (Option P)

This absolute analog position feedback option uses a non-contact sensor requiring a polarity sensitive 5.0 VDC  $\pm$  0.5 VDC supply input (wiring cannot be reversed). Default factory programming provides a nominal output of 0.5 VDC at full retract increasing to a nominal of 4.5 VDC at full extend for any stroke length. This output range can be used for external control sensing of shorts to ground (< 0.5 VDC) or shorts to battery (> 4.5 VDC). Other output ranges can be programmed upon request. Standard strokes offer an output resolution of 0.12 mm and independent linearity of 0.5%. For more information on signal position tolerances, see the Glossary in the back of this catalog.

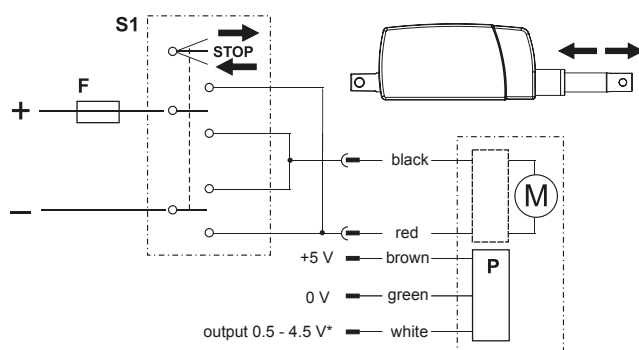

\* From 0.5 V at fully retracted (←) to 4.5 V at fully extended (→).

M = actuator motor, S1 = double pole double throw (SPDT) switch, F = fuse  
P = analog feedback device

- By switching the polarity of the voltage to the motor, the extension tube will change direction.
- Make sure that the switch and the wiring can handle the maximum motor current.
- The actuator voltage must be switched off when reaching the ends of stroke or due to a mid-stroke overload to avoid causing damage to the actuator.
- Always protect the actuator and the wiring by using a fuse between the actuator and the power source.

# Onboard Control Options

## Digital Feedback (Option D)

This option uses a quadrature signal hall-effect device to allow the user to detect the direction, speed of and the amount of movement of the actuator. Direction of travel is determined by observing the phase relationship of the channel A and B outputs (channel A leads when retracting). Speed of travel is determined by counting the number of pulses from either output over a fixed time interval. Amount of actuator displacement is determined by counting the number of pulses from either input and multiplying by the feedback resolution (0.100 mm per count for 58A actuators, 0.200 mm per count for 54A actuators). The feedback circuit requires a polarity sensitive 3.8 - 24 VDC supply input (wiring cannot be reversed). Each of the channel outputs is configured as an open-collector, so external pull-up resistors are required. Each channel is capable of sinking up to 100 mA and can withstand up to 24 VDC.

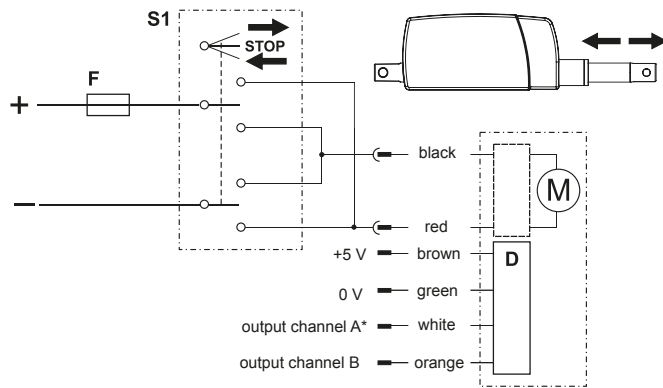

\* Channel A leads channel B when retracting (←).

M = actuator motor, S1 = double pole double throw (SPDT) switch, F = fuse  
D = digital feedback device

- By switching the polarity of the voltage to the motor, the extension tube will change direction.
- Make sure that the switch and the wiring can handle the maximum motor current.
- The actuator voltage must be switched off when reaching the ends of stroke or due to a mid-stroke overload to avoid causing damage to the actuator.
- Always protect the actuator and the wiring by using a fuse between the actuator and the power source.

## Electronic Limit Switches + Digital Feedback (Option Y)

This option includes both the Electronic Limit Switches and Digital Feedback option. The acceptable voltage range for the 12 VDC option is 11 - 18 VDC, and the acceptable voltage range for the 24 VDC is 20 - 32 VDC. The actuator will run slightly slower at the same voltage than with options E or N.

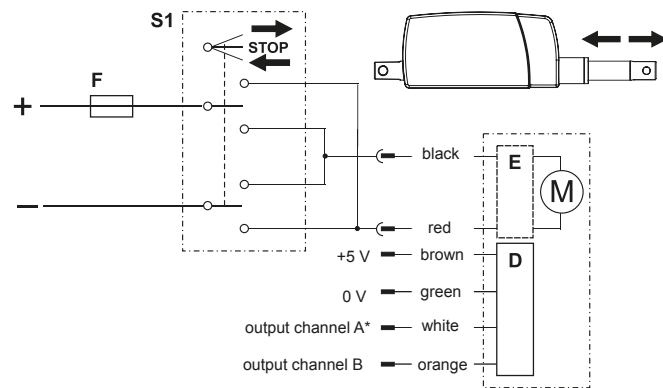

\* Channel A leads channel B when retracting (←).

M = actuator motor, S1 = double pole double throw (SPDT) switch, F = fuse  
E = electronic limit switches, D = digital feedback device

- By switching the polarity of the voltage to the motor, the extension tube will change direction.
- Make sure that the switch and the wiring can handle the maximum motor current.
- The actuator will automatically switch off when reaching the ends of stroke or a mid-stroke overload.
- Always protect the actuator and the wiring by using a fuse between the actuator and the power source.

## Onboard Control Options

### Electronic Limit Switches + Analog Position Feedback (Option Z)

This option includes both the Electronic Limit Switches and Analog Feedback option. The acceptable voltage range for the 12 VDC option is 11 - 18 VDC, and the acceptable voltage range for the 24 VDC is 20 - 32 VDC. The actuator will run slightly slower at the same voltage than with options E or N.

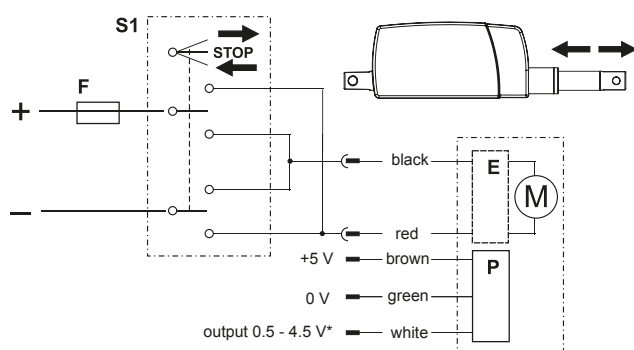

\* From 0.5 V at fully retracted (←) to 4.5 V at fully extended (→).

M = actuator motor, S1 = double pole double throw (SPDT) switch, F = fuse  
E = electronic limit switches, P = analog feedback device

- By switching the polarity of the voltage to the motor, the extension tube will change direction.
- Make sure that the switch and the wiring can handle the maximum motor current.
- The actuator will automatically switch off when reaching the ends of stroke or a mid-stroke overload.
- Always protect the actuator and the wiring by using a fuse between the actuator and the power source.

## DCG Actuator Control - Specifications



### Features

- Controls are available for single actuator operation or dual actuators operated in parallel.
- Small and light weight control operated via a control pendant or cable harness, which is ordered separately.
- Built-in Electronic Limit Switches (ELS) stop the actuator automatically at end of stroke or mid-stroke stall.
- The control pendant or cable harness, is ordered separately.
- Use of this control limits the duty cycle to the actuator to 10%.
- If you choose to use an alternative controller other than the DCG units specified, contact Thomson for further information.

### Dimensions

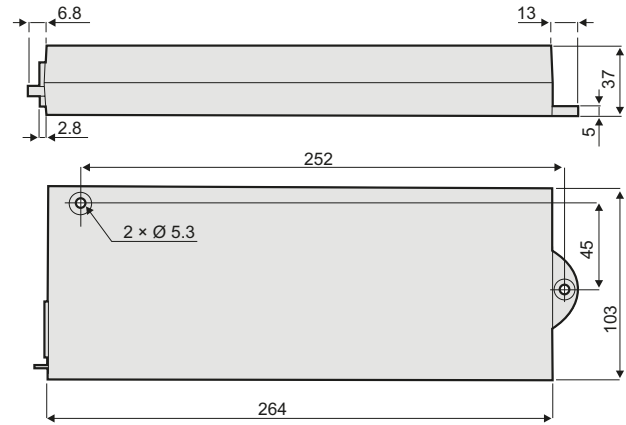

### Actuator Connection

Actuators with cable option 3 can be directly connected to the DCG control. See order key for more information.

### Power Cords and Plugs

DCG24-1U has a 3 m long power supply cable with a US three prong power plug, while DCG24-1M units have a 3 m long cable with an Europlug (CEE 7/16) power plug.

Specifications									
	DCG-152		DCG-154		DCG-252		DCG-254		
Compatible with actuator	W2402-58A●●●N●3●		W2402-54A●●●N●3● W2404-58A●●●N●3●		W2402-58A●●●D●3●		W2402-54A●●●D●3● W2404-58A●●●D●3●		
Input voltage [Vac]	1 × 230 ± 6%	1 × 115 ± 6%	1 × 230 ± 6%	1 × 115 ± 6%	1 × 230 ± 6%	1 × 115 ± 6%	1 × 230 ± 6%	1 × 115 ± 6%	
Input frequency [Hz]	50	60	50	60	50	60	50	60	
Output voltage [Vdc]	24		24		2 × 24		2 × 24		
Output current, max. [A]	2.4		4.8		2 × 2.4		2 × 4.8		
Operating temperature limits [°C]	0 to +30		0 to +30		0 to +30		0 to +30		
Max. duty cycle @ 25 °C [%]	10		10		10		10		
Maximum on time [s]	180		90		180		90		
Weight of control [kg]	0.5		0.5		0.5		0.5		
Protection class	Class I (not for outdoor use)		Class I (not for outdoor use)		Class I (not for outdoor use)		Class I (not for outdoor use)		
Electronic limit switches	yes		yes		yes		yes		
Included control pendant	no		no		no		no		
Compliances/Certificates	CE	UL	CE	UL	CE	UL	CE	UL	
Part number	DCG24-1M-0152	DCG24-1U-0152	DCG24-1M-0154	DCG24-1U-0154	DCG24-2M-0252	DCG24-2U-0252	DCG24-2M-0254	DCG24-2U-0254	

These controls are current limited. Review the current/load curves for the actuator you selected to make sure the control will provide enough current for the thrust you need. Control will shut off if duty cycle is exceeded and automatically reset when cooled off. Control pendant type DCG14-1H is recommended, see page 12.

## DCG Actuator Control - Accessories

### DCG Control Pendant

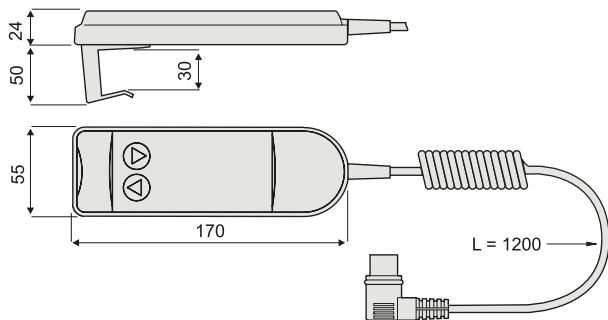

Handy and light weight control pendant with spiral cord cable, which connects to the DCG to control one or synchronous WhisperTrak linear actuators via momentary push buttons.

Specifications	
Parameter	DCG14-1H
Weight [kg]	0.4
Cable length [mm]	1200
Certificates	CE
Part number	DCG14-1H

### Control-to-Control Cable for DCG

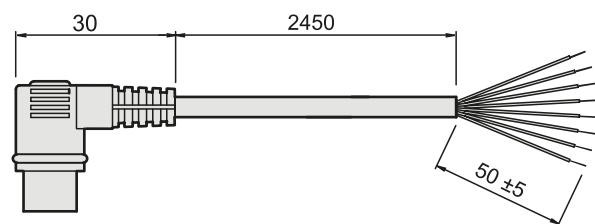

This cable connects with its plug to the control pendant input on DCG in order to connect the control to devices other than the DCG control pendant.

Specifications	
Parameter	
Lead cross section [mm <sup>2</sup> ]	7 × 0.14
Cable length [mm]	2450
Part number	D620 095

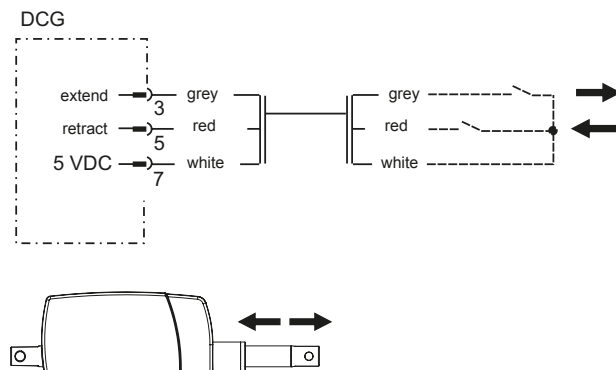

# Glossary

## Acme Screw

Acme screws typically have low efficiencies, which self lock and resist back driving. The low efficiency suits applications with shock and vibration.

## Actuator Housing

The actuator housing provides environmental protection for the internal components and may also be a structural member of the actuator.

## Adapters (Front and Rear Clevis)

The front and rear adapters are the connection points for mounting most Thomson actuators. The front adapter is usually a cross hole but optionally may be a tapped hole, threaded rod, universal rod end or slotted adapter with cross hole. The rear adapter may be cast into the actuator housing or held in place with a nut.

## Analog Feedback Sensor Positional Error

Positional feedback from the actuator is derived from an embedded sensor. Due to the linearity tolerance, the sensor signal may contain an offset (position error) from the standard mm/V specification.

$$\text{Max. position error} = \pm \frac{(\text{input voltage} \times 0.005 \times \text{stroke length})}{\text{output voltage range}}$$

Example:

Input voltage = 5 VDC

Stroke Length = 200 mm

Output voltage range = 4 VDC (0.5 - 4.5 VDC standard output)

$$\text{Max. position error}^1 = \pm \frac{(5 \text{ VDC} \times 0.005 \times 200 \text{ mm})}{4 \text{ VDC}} = \pm 1.25 \text{ mm}$$

<sup>1</sup> Maximum possible error due to sensor linearity only.

## Analog Feedback Sensor Positional Resolution

Positional feedback from the actuator is derived from an embedded sensor. The actuator uses a non-contact device and is limited by the internal bit size of memory registers. This bit size controls the smallest amount of positional movement the actuator can detect and reflect in the sensor signal. For WhisperTrak actuators, all standard strokes have a 0.12 mm resolution.

## Anti-Rotation Mechanism

A feature available on some actuators that resolves the restraining torque within the actuator. The extension tube will not rotate on actuators with this feature.

## Certificates

Standard actuator models that are CE and/or UL recognized component are marked accordingly.

## Controls

Controls can be external to the actuator and provide the actuator with the correct voltage, have either membrane or pendant operators

and some have position indicators. The Thomson WhisperTrak Series of electric linear actuators also has optional internal controls that continuously monitor the operation of the actuator.

## Cover Tube

The cover tube provides protection for the lead screw and provides protection and support for the extension tube. For the Thomson WhisperTrak actuators, the cover tube can also provide the rear mounting connection.

## Customization

Even the most versatile actuator may not always suit all applications. But whatever your need is, our engineers are ready to help you to customize the actuators according to your requirements. We build more exclusive actuators than anyone else and have decades of experience of producing actuators to meet special needs.

## Digital Feedback Quadrature Signal

A quadrature output is used to determine the direction of rotation of a rotating shaft. It consists of two rectangular-wave signals that transition from a HIGH to a LOW state every 180 degrees of rotation, and the signal transitions of each output are offset by 90 degrees of rotation from each other.

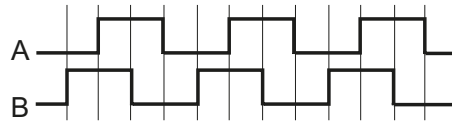

## Digital Feedback Open-Collector Output

An open collector is a common type of output found on many integrated circuits. The output essentially acts as either an open circuit (no connection to anything) or a connection to ground. The output usually has an external pull-up resistor, which raises the output voltage when the transistor is turned off. When the transistor connected to this resistor is turned on, the output is forced to nearly 0 volts. Because the pull-up resistor is external and need not be connected to the chip supply voltage, a lower or higher voltage can be used instead. Open collector circuits are therefore sometimes used to interface different families of devices that have different operating voltage levels.

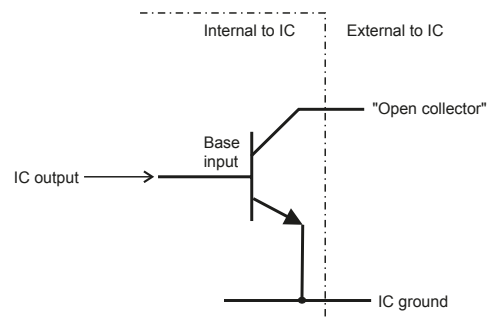



## Glossary

### Duty Cycle

$$\text{Duty cycle} = \frac{\text{on time}}{\text{(on time + off time)}}$$

Example: 10 seconds on, 90 seconds off

$$\frac{10 \text{ s}}{(10 \text{ s} + 90 \text{ s})} = 10\% \text{ duty cycle}$$

The duty cycle is a function of the maximum rated load and the ambient temperature. Ambient temperatures above the stated will affect the duty cycle negatively, while lower temperatures and/or lower load will affect it positively.

### Dynamic Load

The dynamic load rating is how much load the actuator will move when power is applied. Also see "load rating."

### Electronic Limit Switches (ELS)

ELS stands for Electronic Limit Switches and it is a current-sensing function used in some actuator control models. The ELS senses the current, and if the current exceeds a pre-set level, the control cuts the power to the motor. This function can be used to detect and stop at the ends of the actuator stroke or to stop the actuator if it runs into an obstacle.

### End Play (Backlash)

The stack up of tolerances within the lead screw assembly and gearing, allowing some linear movement of the extension tube without rotating the motor.

### Extension Tube

The extension tube slides in and out of the actuator and is connected via the front adaptor to the load being moved or positioned.

### Feedback

Thomson WhisperTrak actuators have the option to be equipped with either an analog or a digital position feedback.

### Input Voltage

The nominal voltage required to operate the actuator. All actuators will accept at least a  $\pm 10\%$  variation of the nominal voltage, but a change in the voltage will result in a change of the speed of DC actuators. Controls are available that accept 115 or 230 Vac input and provide 24 Vdc output to operate 24 Vdc actuators.

### Installation Instructions

Each actuator has an installation manual to answer typical questions about mounting and wiring the actuators.

### Lifetime Expectancy

Life is a function of load and stroke length.

### Linear Actuators

Actuators providing a linear thrust via an extension tube to lift, lower, push, pull or position a load.

### Load Rating

The load rating is the minimum amount of force the actuator will provide during its lifetime. The load rating of all rod-style actuators is the same for both compression and tension loads. Also see "dynamic load", "static load" and "tension and compression load."

### Maximum On Time

The maximum amount of time an actuator may operate without stopping to "cool off". For high-load and long-stroke actuators, this may be one extend or retract cycle. The actuator should not exceed 10% duty cycle at full rated load.

### Mounting

Electrak actuators are quickly and easily mounted by slipping pins through the holes on each end of the unit and into brackets on the machine frame and the load. Roll- or spring-type mounting pins should be avoided. The load should act along the axis of the actuator since off-center loads may cause binding (Fig. a). The mounting pins must be parallel to each other and be secured in both ends as shown below (Fig. b). Pins which are not parallel or properly secured in both ends may cause the actuator to bind.

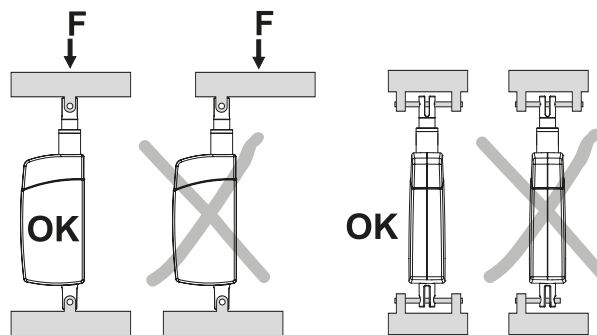

Fig. a

Fig. b

### Operating and Storage Temperature

The operating temperature is the range in which the actuator may be safely operated. At higher temperatures, the duty cycle needs to be lower than 10%. All actuators can be stored or transported at the same temperature as the operating temperature. Contact customer support if the operating temperature will be exceeded during storage or transportation.

### Output Voltage

Output voltage is the voltage from the control to run the actuator. The controls for DC actuators have 24 Vdc output. The controls for AC actuators have either 115 or 230 Vac output.

# Glossary

## Protection Class

The protection class refers to the environmental rating of the enclosure. The first digit applies to airborne contaminants and the second digit to water/moisture.

IP65: dust tight and protected against low-pressure water jets (12.5 liter/min) from any direction.

IP66: dust tight and protected from powerful water jets (100 liter/min) from any direction.

IP67: dust tight and protected against the effect of immersion in water between 150 mm (5.9 inch) and 1 meter (39.4 inch).

## Restraining Torque

The torque which is developed between the clevis on the extension tube and rear mount (clevis or trunnion) when the unit extends or retracts (Fig. c). If the actuator is equipped with an anti-rotation mechanism, there is no restraining torque. If not, the application must resolve this torque for proper application function.

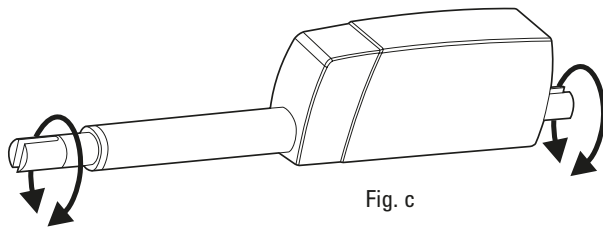

Fig. c

## RoHS Compliance

All actuators, controls and accessories sold in the EU are RoHS compliant unless otherwise stated, while products sold outside of the EU may not be. If you order an actuator outside of the EU and need it to be RoHS compliant, contact the factory to verify availability and be sure to include the request on your order.

## Service and Maintenance

Actuators are maintenance free.

## Sizing and Selection

The Thomsonlinear.com web site includes a product advisor that can be used to walk you through the decision-making process for choosing the best actuator and using the proper ordering data for your choice. Go to [www.thomsonlinear.com/linear\\_actuator\\_advisor](http://www.thomsonlinear.com/linear_actuator_advisor) to find out more.

## Speed

DC actuators have an inverse load/speed relationship. As the load increases, the speed of the DC actuators decreases. There are curves to show the speed from no load to full rated load.

## Static Load

The static load rating is how much load the actuator will hold with power off. Also see "load rating." If nothing else is stated, the static load rating is for the actuator extension tube being fully retracted. The static load rating will decrease as the tube extends.

## Synchronous Operation

Without feedback control, the motor speed cannot be controlled with enough precision to ensure that the actuators will remain synchronized, and a binding effect could take place. Actuators equipped with a digital feedback encoder can be synchronized using DCG controls designed for synchronous operation.

## Tension and Compression Load

A tension load tries to stretch the actuator, and a compression load tries to compress the actuator (Fig. d). Most actuators can manage the same tension and compression load. Also see "load rating."

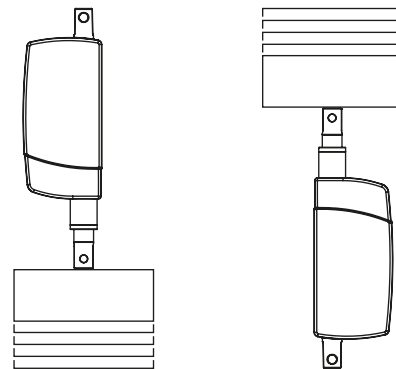

Fig. d

## Trapezoidal Screw

Screw type with similar characteristics as an acme screw. Also see "acme screw."

## Voltage Drop

Long leads/cables between the power source and the actuator will result in a voltage drop for DC units. This voltage drop can be avoided by sizing the leads in accordance with the following lead cross section selection table. The table is based on an ambient temperature of 30°C or less. A higher ambient temperature may result in the need for a greater lead cross section.

Lead Cross Section Selection Table [mm <sup>2</sup> ]			
Current draw [A]	Cable length [m]	Actuator input voltage [Vdc]	
		12	24
0 - 10	0 - 3	1.5	1.5
	3 - 6	2.5	1.5
	6 - 10	4	1.5
10 - 15	0 - 3	1.5	2.5
	3 - 6	2.5	2.5
	6 - 10	4	2.5
15 - 20	0 - 3	2.5	4
	3 - 6	4	4
	6 - 10	6	4



## **USA, CANADA and MEXICO**

Thomson  
203A West Rock Road  
Radford, VA 24141, USA  
Phone: 1-540-633-3549  
Fax: 1-540-633-0294  
E-mail: [thomson@thomsonlinear.com](mailto:thomson@thomsonlinear.com)  
Literature: [literature.thomsonlinear.com](http://literature.thomsonlinear.com)

## **EUROPE**

### **United Kingdom**

Thomson  
Office 9, The Barns  
Caddsdow Business Park  
Bideford  
Devon, EX39 3BT  
Phone: +44 (0) 1271 334 500  
E-mail: [sales.uk@thomsonlinear.com](mailto:sales.uk@thomsonlinear.com)

### **Germany**

Thomson  
Nürtinger Straße 70  
72649 Wolfschlügen  
Phone: +49 (0) 7022 504 0  
Fax: +49 (0) 7022 504 405  
E-mail: [sales.germany@thomsonlinear.com](mailto:sales.germany@thomsonlinear.com)

### **France**

Thomson  
Phone: +33 (0) 243 50 03 30  
Fax: +33 (0) 243 50 03 39  
E-mail: [sales.france@thomsonlinear.com](mailto:sales.france@thomsonlinear.com)

### **Italy**

Thomson  
Largo Brughetti  
20030 Bovisio Masciago  
Phone: +39 0362 594260  
Fax: +39 0362 594263  
E-mail: [info@thomsonlinear.it](mailto:info@thomsonlinear.it)

### **Spain**

Thomson  
E-mail: [sales.esm@thomsonlinear.com](mailto:sales.esm@thomsonlinear.com)

### **Sweden**

Thomson  
Estridsväg 10  
29109 Kristianstad  
Phone: +46 (0) 44 24 67 00  
Fax: +46 (0) 44 24 40 85  
E-mail: [sales.scandinavia@thomsonlinear.com](mailto:sales.scandinavia@thomsonlinear.com)

## **ASIA**

### **Asia Pacific**

Thomson  
E-mail: [sales.apac@thomsonlinear.com](mailto:sales.apac@thomsonlinear.com)

### **China**

Thomson  
Rm 2205, Scitech Tower  
22 Jianguomen Wai Street  
Beijing 100004  
Phone: +86 400 6661 802  
Fax: +86 10 6515 0263  
E-mail: [sales.china@thomsonlinear.com](mailto:sales.china@thomsonlinear.com)

### **India**

Thomson  
c/o Fluke Technologies Pvt. Ltd.  
#424, Deodhar Center,  
Marol Maroshi Road,  
Andheri – E, Mumbai – 400059 India  
Phone: +91 22 29207641  
E-mail: [sales.india@thomsonlinear.com](mailto:sales.india@thomsonlinear.com)

### **Japan**

Thomson  
Minami-Kaneden 2-12-23, Suita  
Osaka 564-0044 Japan  
Phone: +81-6-6386-8001  
Fax: +81-6-6386-5022  
E-mail: [csjapan@scgap.com](mailto:csjapan@scgap.com)

### **Korea**

Thomson  
F7 Ilsong Bldg, 157-37  
Samsung-dong, Kangnam-gu,  
Seoul, Korea (135-090)  
Phone: +82 2 6917 5049  
Fax: +82 2 528 1456  
E-mail: [sales.korea@thomsonlinear.com](mailto:sales.korea@thomsonlinear.com)

## **SOUTH AMERICA**

### **Brazil**

Thomson  
Av. Tamboré, 1077  
Barueri, SP – 06460-000  
Phone: +55 (11) 3616-0191  
Fax: +55 (11) 3611-1982  
E-mail: [sales.brasil@thomsonlinear.com](mailto:sales.brasil@thomsonlinear.com)