

GP SERIES

Unitary Piston Compressor



Benefits

- Long Service Free Life
- Low Vibration & Sound Level
- Corrosion Resistance
- Cool Operating Temperature
- Restart Against Load

Features

- Thin-walled, Hard Coated Anodized Cylinder
- Oil-less, Non-lube PTFE Piston Seal
- Permanently Lubricated Ball Bearings
- Proven "Unitary Piston" Technology
- Dust & Moisture Resistant
- Integrated Inlet Filter
- Balanced Eccentric/Connecting Rod Assembly
- Epoxy E-Coated Wetted Aluminum Components
- Stainless Steel Valves, Retainers and Screws
- Die Cast Aluminum Components
- High Torque DC Motor



TruNorth Components, Inc.

2100 Sunset Drive
Plymouth, WI 53073
Phone: (855)449-7867

www.trunorthcomponents.com



TruNorth Components, Inc.
 "A Principle Driven Company"

GP Series Performance Data

Model Number	GP12-AE38
Head Configuration	Pressure Only
Free Air Flow	0.94 SCFM
Max Continuous Pressure	N/A
Max Intermittent Pressure	120 PSIG
Max Restart Pressure	120 PSIG
Max Ambient Air Temp	125° F
Min Ambient Start Temp	-20° F
Motor Voltage/Frequency	115V/60Hz
Motor Type	Permanent Magnet
Current at Rated Load	16 Amps
Power at Rated Load	193 Watts
Max Duty Cycle - (Minutes)	(3 on/27 off)
Starting Current (Locked Rotor)	48 Amps
Min Full Load Speed	3550 RPM
Thermal Protector	N/A
Net Weight	2.72 lbs.

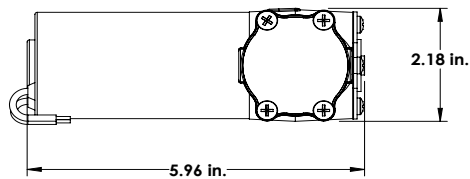

16 GAUGE LEAD WIRES, 7.9" +/- .6" LONG,
 (1) BLACK, (1) RED

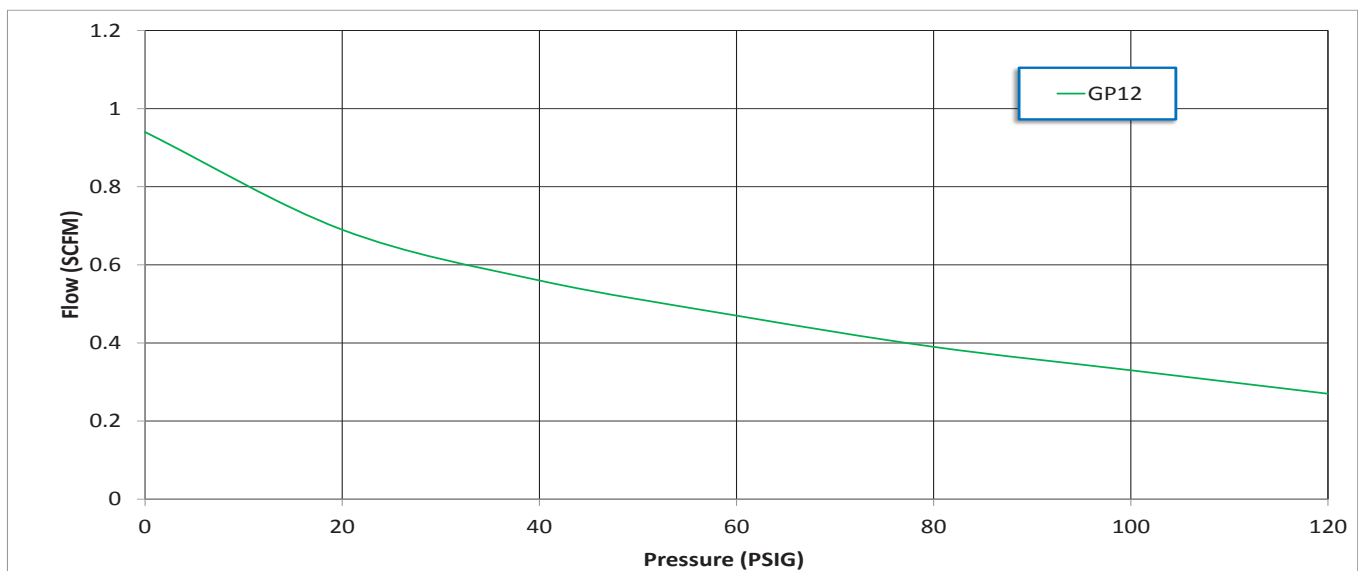
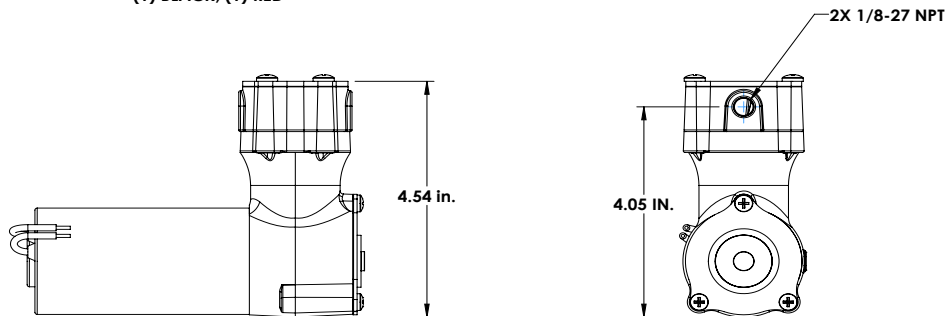

The information presented in this material is based on technical data and test results of nominal units. It is believed to be accurate and reliable and is offered as an aid to help in the selection of TruNorth products. It is the responsibility of the user to determine if this product is suitable for the intended use. The user assumes all risk and liability whatsoever in connection therewith. TruNorth does not warrant, guarantee or assume any obligation in connection with this information.