

MP SERIES SINGLE

Unitary Piston Compressor/Vacuum Pumps



Benefits

- Long Service Free Life
- Low Vibration & Sound Level
- Corrosion Resistance
- Cool Operating Temperature
- Electrically Safe
- Low Power Consumption
- Customization

Features

- Thin-walled, Hard Coated Anodized Cylinder
- Oil-less, Non-lube PTFE Piston Seal
- Permanently Lubricated Ball Bearings
- Proven "Unitary Piston" Technology
- Inlet filter/ Exhaust Muffler
- Balanced Eccentric/Connecting Rod Assembly
- Epoxy E-Coated Wetted Components
- Stainless Steel Valves, Retainers and Screws
- Front Mounted 9-Blade Fan
- Die Cast Aluminum Components
- UL Recognized Motor & Thermal Protector
- Efficient 4.8" Diameter Motor
- Fan Guard
- Power Cord/ Termination
- Consult Factory for Further List of Options



TruNorth Components, Inc.

"A Principle Driven Company"

TruNorth Components, Inc.

2100 Sunset Drive
Plymouth, WI 53073

Phone: (855)449-7867

www.trunorthcomponents.com



TruNorth Components, Inc.

"A Principle Driven Company"

MP Series Performance Data

Model Number	MP22-CC44	MP27-CC48
Head Configuration	Pressure/Vacuum	Pressure/Vacuum
Free Air Flow	1.72 SCFM	2.65 SCFM
Max Continuous Pressure	100 PSIG	45 PSIG
Max Intermittent Pressure	100 PSIG	50 PSIG
Max Restart Pressure	100 PSIG	50 PSIG
Max Vacuum	27.5" Hg	27.5" Hg
Max Restart Vacuum	27.5" Hg	27.5" Hg
Max Ambient Air Temp	104° F	104° F
Min Ambient Start Temp	50° F	50° F
Motor Voltage/Frequency	115V/60Hz	115V/60Hz
Motor Type	PSC	PSC
Current at Rated Load	4.4 Amps	4.7 Amps
Power at Rated Load	420 Watts	530 Watts
Starting Current (Locked Rotor)	18 Amps	18 Amps
Capacitor Value	12.5 µF	12.5 µF
Min Full Load Speed	1738 RPM	1712 RPM
Thermal Protector	Yes	Yes
Net Weight	12.3 lbs.	12.3 lbs.

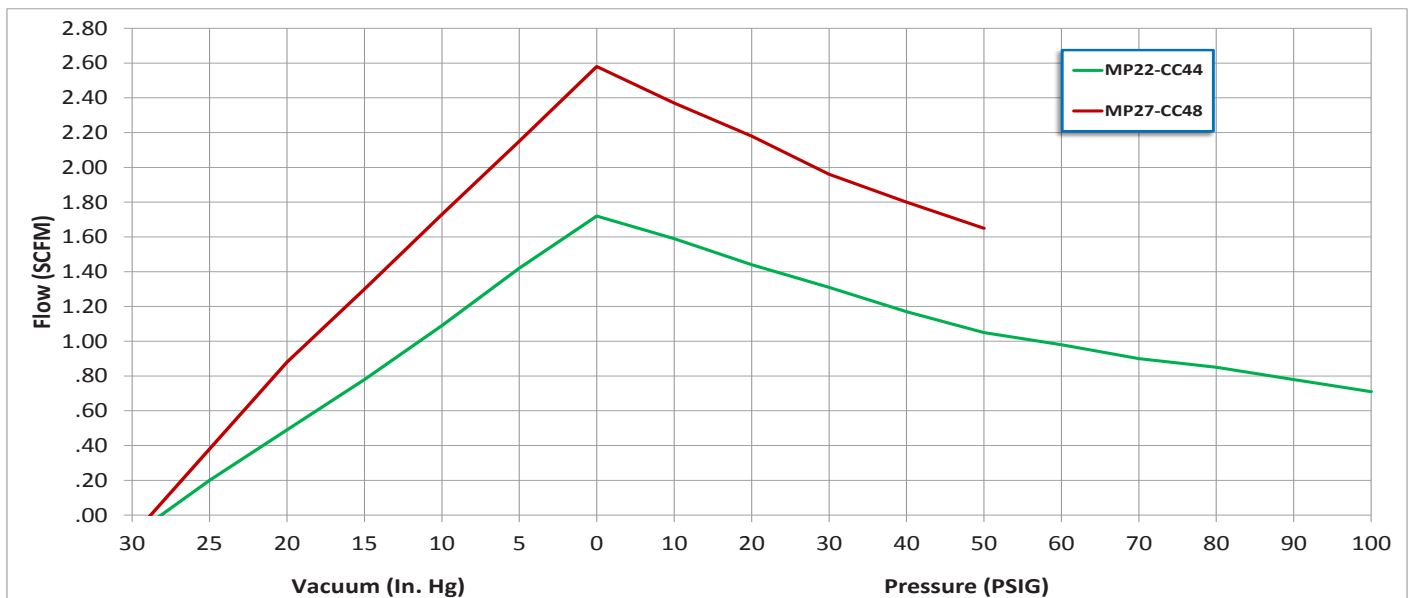
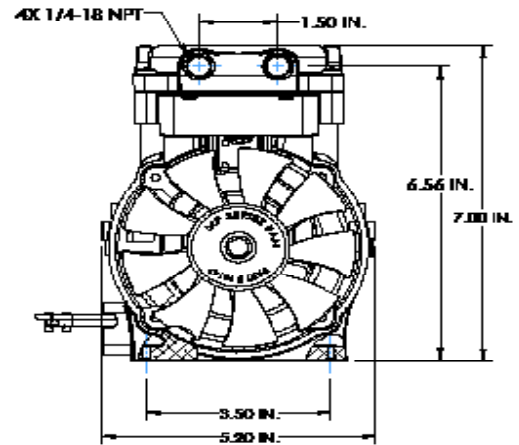
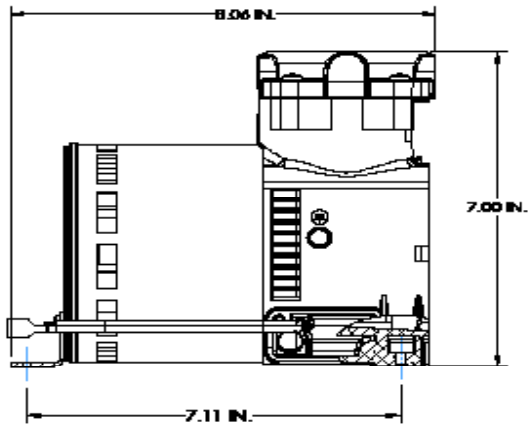
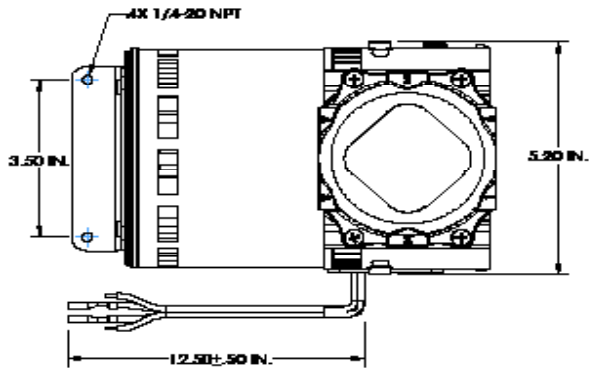

The information presented in this material is based on technical data and test results of nominal units. It is believed to be accurate and reliable and is offered as an aid to help in the selection of TruNorth products. It is the responsibility of the user to determine if this product is suitable for the intended use. The user assumes all risk and liability whatsoever in connection therewith. TruNorth does not warrant, guarantee or assume any obligation in connection with this information.