

80/20[®]

The Industrial Erector Set[®]

**CATALOG
22**

www.8020.net



EVERYONE WANTS TO MAKE SOMETHING

Hands-on 80/20 Demonstration

The 80/20 demonstration van travels right to you so that you can see and interact with the products as well as experience 80/20 in action. The van transports a gurney with samples of profiles, fasteners, panels, accessories and more so that you have the chance to get hands-on with our variety of products. Your wheels will start turning as you begin to imagine all of the versatile ways you can use 80/20.

Have an **80/20[®] Inc.** specialist come to your door for on-site training and demonstrations.

80/20

*Request
your demo!*



CALL 260-248-8030 TODAY!

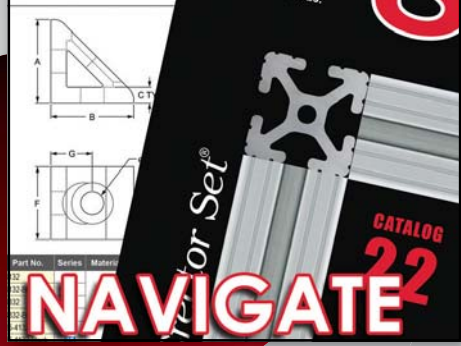

Quick Reference Guide to Catalog 22

What is 80/20	2
Made With 80/20 Stuff	6
Peace of Mind	29
Design Tools	34
80/20 Services	36
Ordering Information	45
Profiles	49-196
T-slotted Profiles	74
Ready Tube	182
Quick Frame	189
Fastening Methods	197-440
Internal Fasteners	212
External Fasteners	225
Variable Connectors	334
Hardware	362
Bolt Assemblies	405
Ready Tube Connectors	417
Quick Frame Connectors	423
Panels & Doors	441-592
Panel Types	450
Blocks, Brackets, Clamps & Retainers	470
Hinges & Roller Wheels	509
Handles & Latches	558
Floor to Frame	593-652
Casters & Leveling Feet	597
Base Plates	629
Add-On Components	653-764
Linear Motion	660
Linear Bearing Pads & Brakes Kits	696
Dynamic Pivots	710
Pressure Manifolds	750
Gravity Rollers, Rods & Stoppers	760
Stanchions	765-780
Finishing Your Frame	781-818
Structural Shapes	819-848
Machining Services	849-898
Tools	899-908
Index	909-944

1) Quick Reference Guide

Page one contains a table of contents.

2) Pictorial Overview

Each section will begin with a visual product overview.

1515-UL Profile



Page 97

Anchor Fastener



Page 212

3) Part Number Index

Use this index (located at the back of the catalog) to find more information about a specific product.

Part No.....	Page No.
1001.....	66, 77
1002.....	66, 79
1003.....	66, 81
1004.....	66, 83
1010.....	66, 75

4) Product Type Index

This index (located at the back of the catalog) provides information about product groups.

Part Description.....	Page No.
Anchor Fasteners	212-215
End Fasteners	217-219
45 Degree Supports	226-232
Flat Plates.....	233-238
Transition Plates.....	239-250



What is 80/20?

80/20[®] Inc.

The *Industrial Erector Set*[®]

WHAT WE'RE ALL ABOUT

First and foremost, I'm sure you're wondering "What is 80/20?" Who are we, what do we sell, and what's our value. Simply stated, 80/20 is a T-slot aluminum construction system you can use to build virtually anything.

When you think of 80/20 think of "an erector set" for adults. You mix, match, assemble and reassemble our products to create your customized solution or innovation.

We go above and beyond selling parts and pieces; we offer an experience. 80/20 provides a one-stop shop for our customers.

We offer several services such as technical design assistance, custom machining, assembly services, and an in-house custom panel shop. 80/20 ensures that our customers can expect a high-quality product each and every time; consistency is a hallmark.

Where You'll Find Us

You'll find us everywhere! Once you've been introduced to 80/20 T-slot profiles and products you'll start noticing that you see it all the time. Some of our most recognized industries include Industrial Manufacturing, Healthcare, Robotics, Automation, and DIY Home-Hobbyists.

While this is a sampling of areas where you'll frequently find 80/20, we hit just about any industry you can think of. Research & Development, Exhibits & Displays, Material Handling, Food & Beverage, or Energy? We're there. And the list goes on. 80/20 is the modular choice for your custom project.



Why the Name 80/20?

In business, the 80/20 theory is a powerful tool. This theory is called Pareto's Law after Vilfredo Pareto (1843-1923), an Italian economist and sociologist who said that 80% of your results come from 20% of your efforts. We run our organization based upon this theory and everyone shares in the advantages.



Vilfredo Pareto

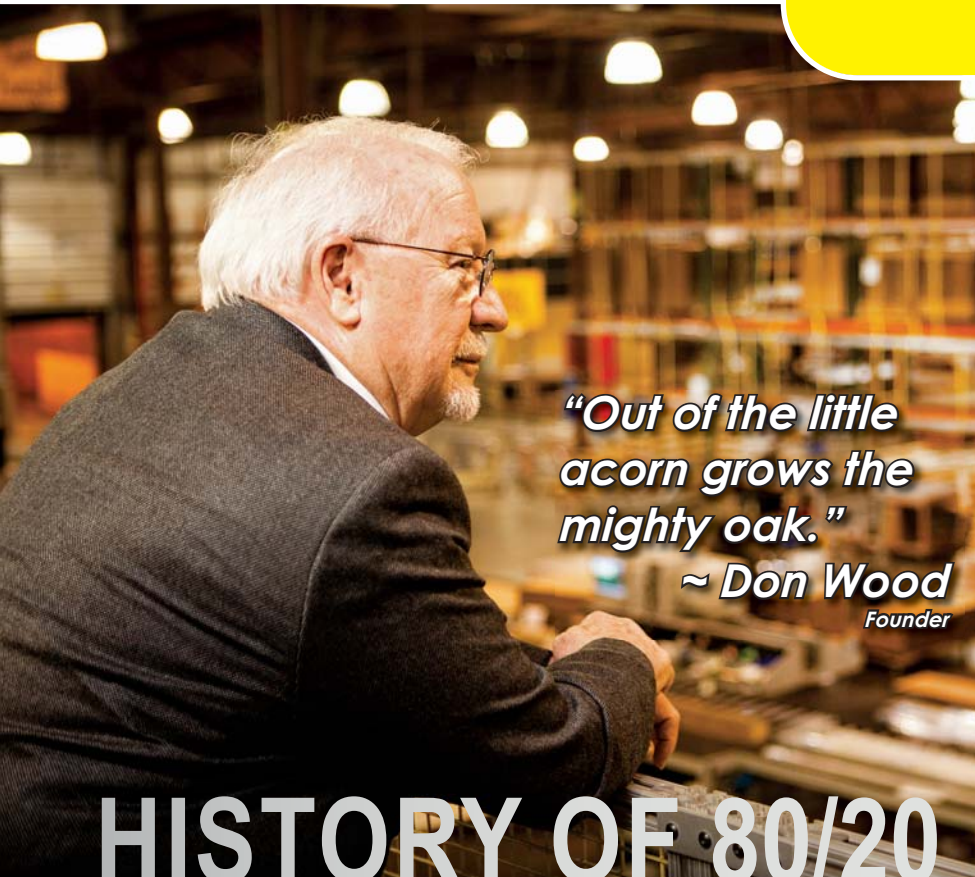

“Out of the little acorn grows the mighty oak.”

*~ Don Wood
Founder*

HISTORY OF 80/20



1989



1992

Through the vision of Don Wood, what began in 1989 as a 3,000 square foot building grew, in its first 25 years, to over 350 employees on a campus of approximately 300,000 square feet in Columbia City, Indiana.

For a snapshot of where we began and how much we've grown, consider that the first catalog was a black and white 8 page pamphlet; today our catalog is hundreds of pages and continually expanding.



2006



Built for the future

2014

What is 80/20?

Attitude is Everything at 80/20

We've achieved this growth by being continually focused on quality, innovation, and improvement. This level of quality is a result of our culture here at 80/20 which revolves around attitude.

At 80/20 we know that personal attitude is the one thing everybody can control. We hand-pick our employees and have found that those with a positive attitude thrive. Our culture just flat out doesn't tolerate a negative attitude.

This positive-attitude culture leads to empowerment of our people and a customer-driven vision. The lens through which we see the world and make business decisions is focused on our value to the customer.

"I am convinced that life is 10% what happens to me and 90% how I react to it."

~ Charles Swindoll

80/20® Inc.

The Industrial Erector Set®

80/20's success evolved from a blend of creative product innovations, a strong sense of our customers' needs, and an "ATTITUDE"!

The "80/20 ATTITUDE" is the cornerstone of our company. It is a reflection of our service to you, our customers, our decades of industry experience, and our willingness to do what it takes to get the job done.

There are a lot of things going on in this world that we cannot control. We cannot control gas prices, the decisions our government leaders make or the weather but we are in charge of our attitudes.

~ Don Wood, Founder

ATTITUDE
IS EVERYTHING
1997

How 80/20's T-Slotted Aluminum Profiles Reduce Your Fabrication Time and Cost

80/20's T-Slotted Aluminum

24" x 24" x 18" 20 Lbs.



\$189.05

VS

\$236.19

Welded Steel Frame

24" x 24" x 18" 33 Lbs.



What it Takes:

1. Design time
2. Bill of materials
3. Purchase materials
4. Assemble frame per design

Benefits:

- No welding - no fighting heat stress or warping
- No priming or painting
- Lightweight, easy to machine
- Uses standard fractional or metric fasteners
- Less engineering time required
- Easy to fabricate - only simple hand tools
- T-slot technology is industry accepted
- Great aesthetic value
- No expensive fabricating equipment required
- Frames can be easily reconfigured for changes

Bill of Materials:

Qty.	Description	Cost
4	1515-Lite x 18"	32.40
4	1515-Lite x 21"	37.80
8	#7010 Saw Cut	15.60
8	#4301 Inside Corner Brackets	34.40
32	#3320 5/16-18 x 5/8" FBHSCS & T-nut	19.20
1	6110 T-Handle Ball End Hex Wrench	5.00
1	6100 Ball End Hex Wrench	1.75
4	2030 End Caps	5.40

1/2 hr. labor to assemble @ \$75.00/hr \$37.50

Total Project Cost: \$189.05

What it Takes:

1. Design time
2. Bill of materials
3. Purchase materials
4. Cut to length
5. Deburr
6. Set up fixture
7. Weld
8. Grind welds
9. Clean weld splatter
10. Drill and/or tap for mounting accessories
11. Degrease
12. Mask non-paint areas
13. Primer coat
14. Paint

Fabricating Equipment Required:

- Band saw
- Grinder
- Welder
- Paint booth
- Skilled labor

Bill of Materials:

Qty.	Description	Cost
4	1.5" x 1.5" x 1/8" wall x 18" Steel Tube	38.96
4	1.5" x 1.5" x 1/8" wall x 21" Steel Tube	44.23
—	Welding Supplies, Sandpaper, Cleaning Supplies, Tape, Paint, etc.	33.00

4 hrs. labor @ \$30.00/hr \$120.00

Total Project Cost: \$236.19

Made with 80/20 Stuff

80/20[®] Inc.

OUTSIDE THE BOX



To see more applications made with 80/20[®] visit 8020.net



GUARDING & ENCLOSURES



BEFORE

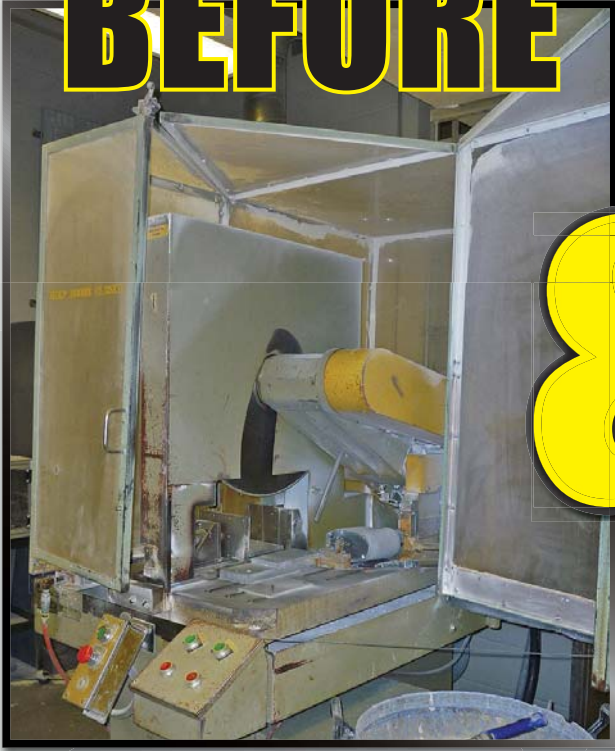

&



AFTER



MACHINE FRAMES

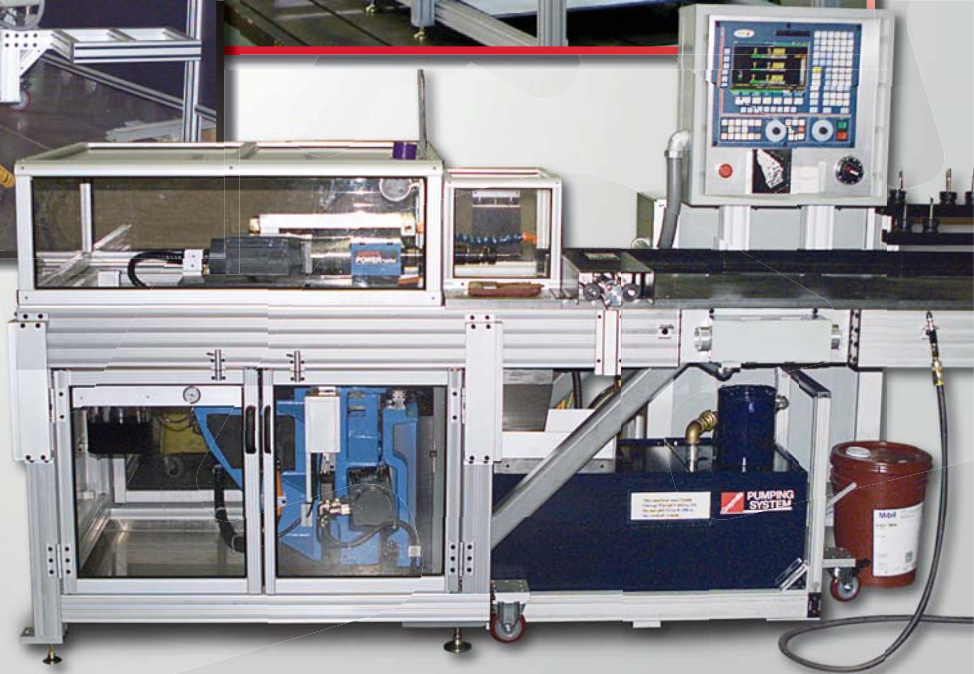

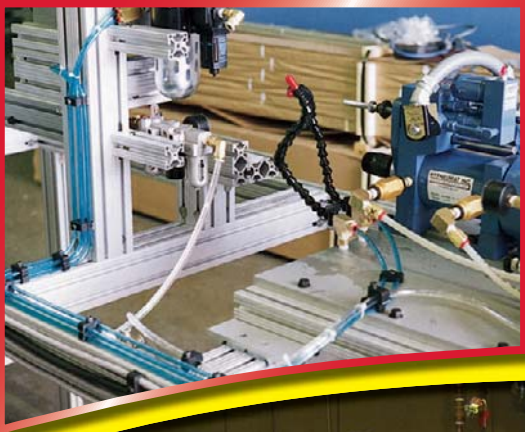

MATERIAL HANDLING





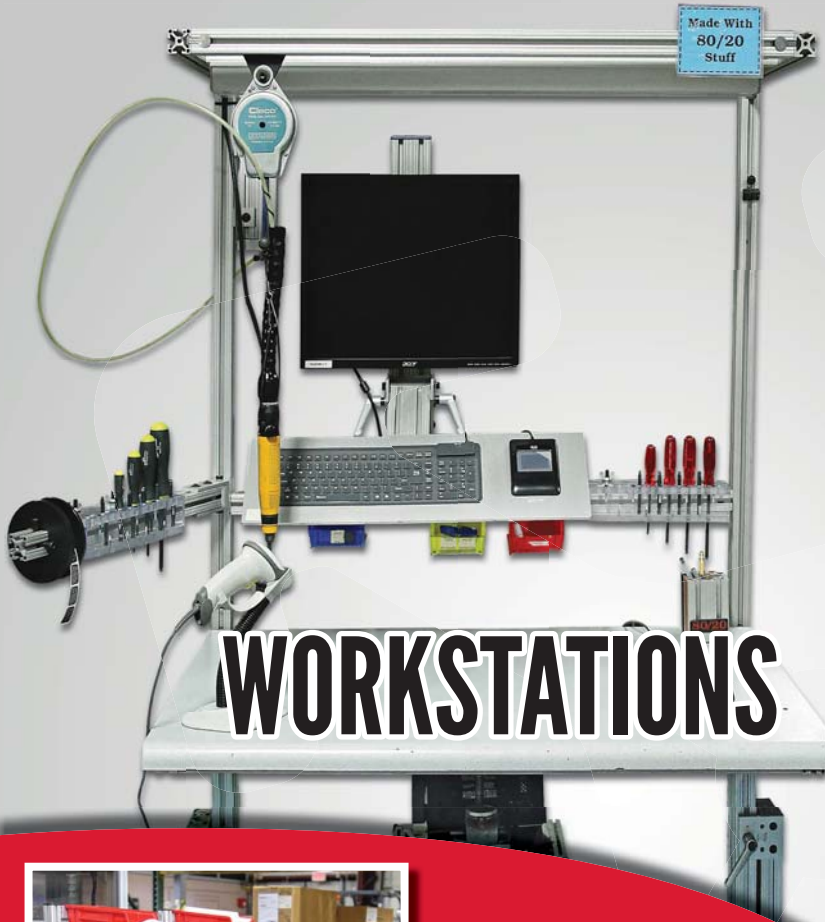

WORKSTATIONS

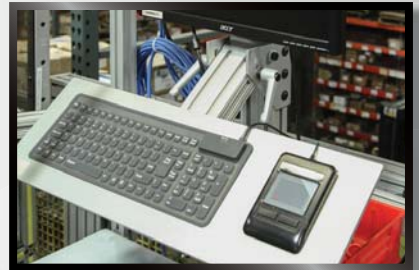

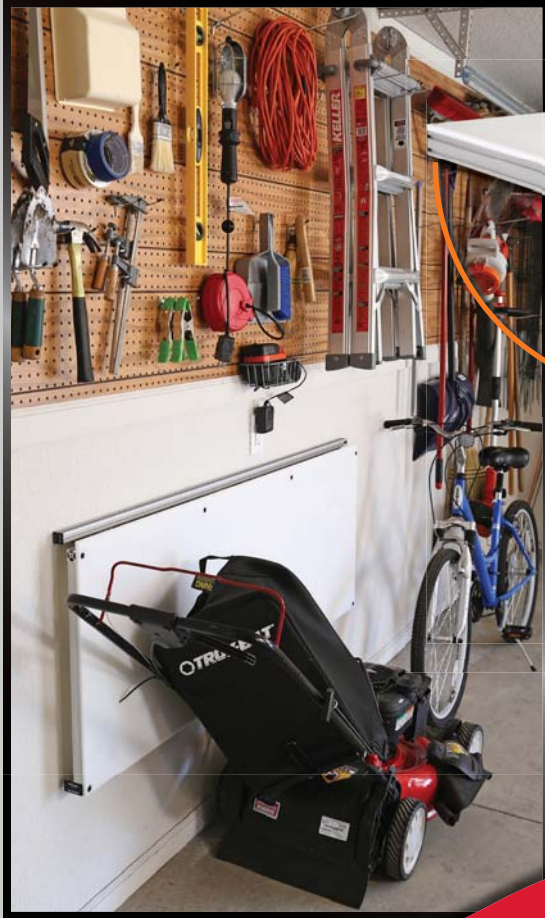



DISPLAYS





BLACK ANODIZE

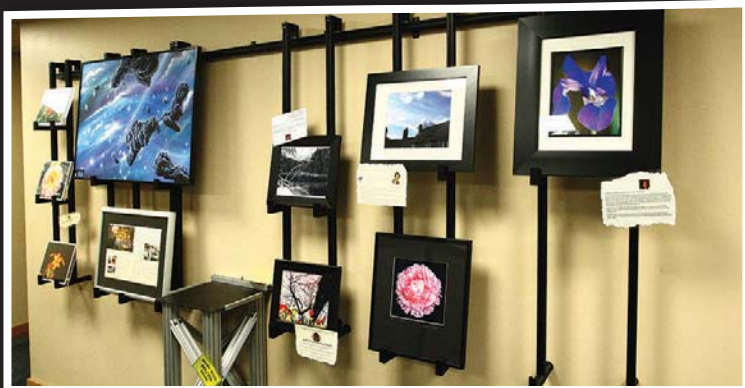

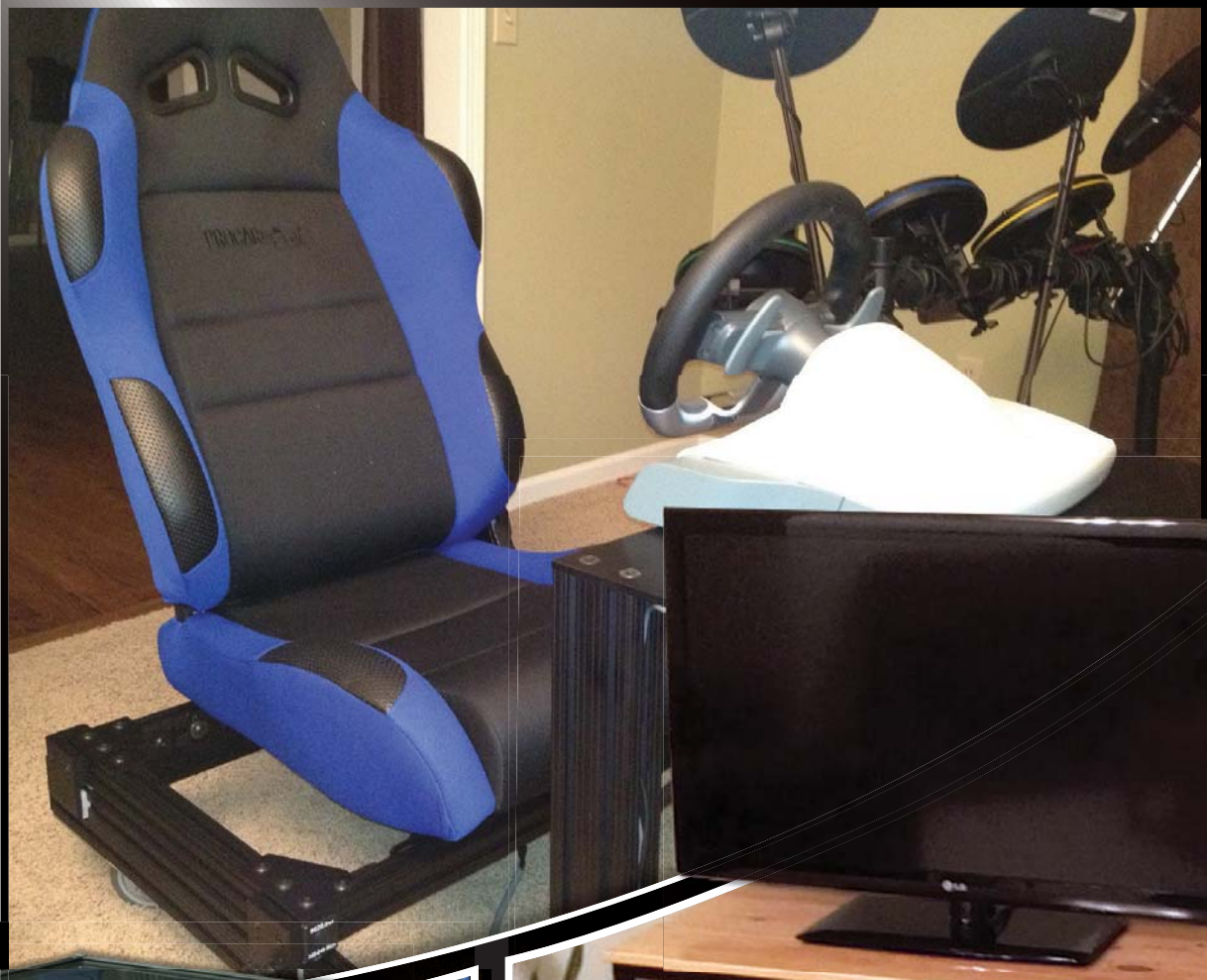

AUTOMATION



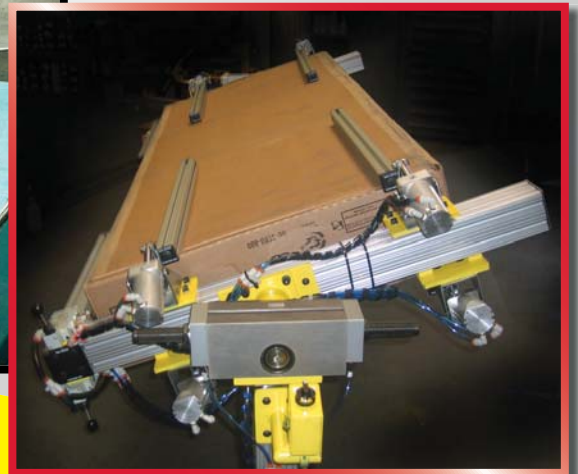



FACILITY





DO-IT-YOURSELF



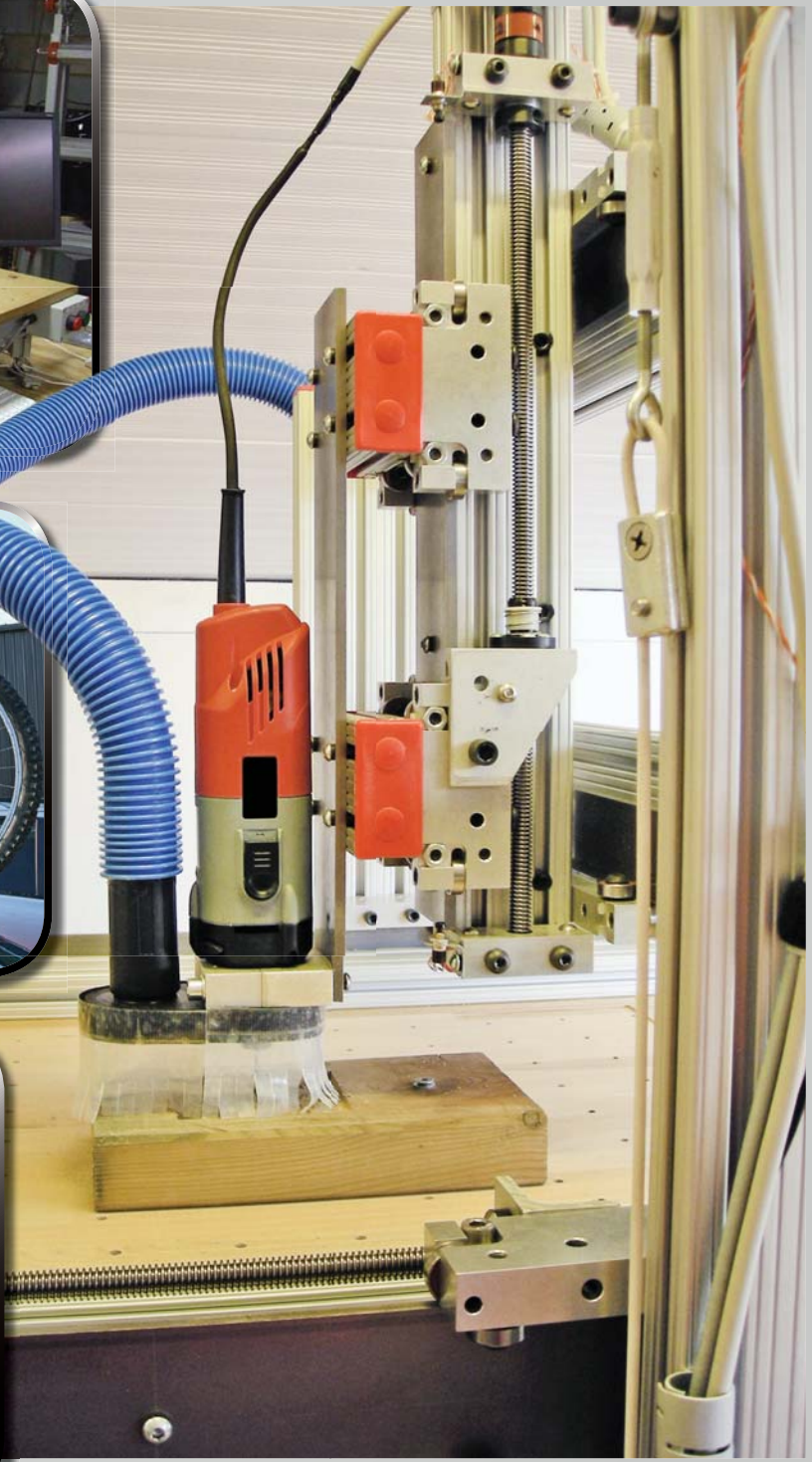
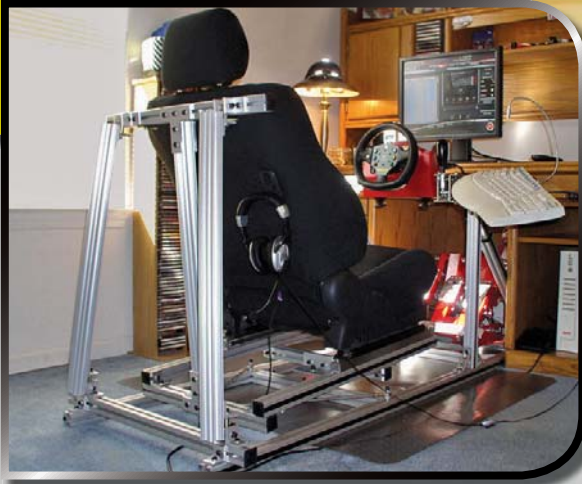



Quick-Frame™



Ready Tube™



Made with 80/20 Stuff

80/20[®] Inc.

80/20[®] Inc.

Xtreme DIY



What You Can Expect With 80/20's Peace of Mind

We want you to know exactly what you can expect when partnering with 80/20. Our philosophy is to provide you with peace of mind; every day we strive to meet and exceed your expectations. Browse through the following pages for more details about these topics.

- **ONE-STOP-SHOP** – Avoid the hassles and inefficiencies of multiple vendors. With 80/20 you have it all in one place. See page 30 for more details.
- **DESIGN ASSISTANCE** – When you need help taking your project beyond a sketch 80/20 provides design assistance. Send us your drawing and dimensions and we'll get you started. For more details see page 33.
- **FREE AUTOMATED QUOTATION SOFTWARE** - You have a range of software options to choose from such as AutoQuoterX™ II, 3D Content Central®, Tech Toolkit™, and Part Solutions™ to make design easy. Visit page 34.
- **FREE DRAWING FILES** - Integrate 80/20 product into your existing design. Choose from 3D, 2D, and more for most design programs. Download drawing files at www.8020.net.
- **80/20 BUILDS** - Let 80/20's team of seasoned builders construct your project for you. Get all the details on page 36.
- **CUSTOM MACHINING** - When you need a unique part take advantage of our Custom Machining service. We can machine any part or piece from the 80/20 catalog or beyond to help fit your need. Additional details on page 38.
- **CUSTOM PACKAGING** - When you need something beyond 80/20's standard packing for your order, we offer a custom packaging service to accommodate your more detailed and specific requirements. See page 44.
- **NO MINIMUM ORDERS** - If you need it, we'll ship it. We appreciate all of your business, even the small orders.
- **LOCAL DISTRIBUTORS** – You will receive extensive field support through the 80/20 distributor network. On-site project evaluations, technical support, and demonstrations are just a phone call away. For more details see page 32.
- **LARGEST PRODUCT OFFERING IN THE BUSINESS!**
- **YOU ARE THE BOSS – WE SERVE YOU!**

Peace of mind means you have a partner in creating your project...from concept to design to implementation.

Concept

It starts with an idea. Sketch it and create it with 80/20.

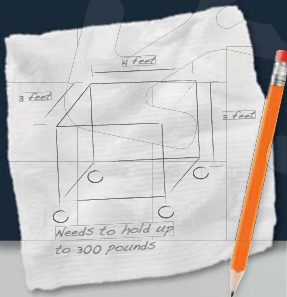

Design

Build to your specific needs with 80/20 T-slot modularity.

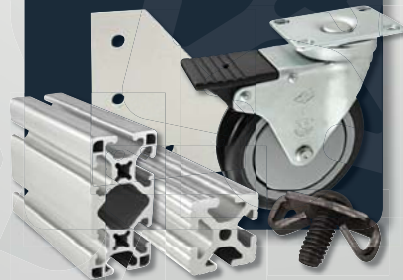

Completion

80/20 will build your project to your specifications.



One-Stop-Shop

80/20 One-Stop-Shopping means you get convenient and efficient products and solutions, as well as the services to augment your order, all in one place. Save the time, hassle, and headache that come from working with multiple vendors.



Our commitment to being your one-stop-shop means that we have no minimum orders; we want ALL of your business. We know that your project is unique and that you need the flexibility to order in small or large quantities.

It also means we listen to your needs and continually add to our stock of products. We already have the largest product offering in the industry and it's only going to continue to grow! Our products are customer-driven and always expanding. And if it's something we don't currently carry, we'll source it for you.

In order to make your 80/20 experience simple and straightforward we have in-house capabilities to support our dedication to being your one-stop-shop. These are top-of-the-line machine shops and services that produce at the same level of quality you can expect with anything 80/20. These valuable resources are at your disposal to streamline your processes and save you time.

Call one of our Design Technicians today about making 80/20 your one-stop-shop

80/20 Difference

We know how frustrating it is when that order you placed arrives damaged, with incorrect parts, or in poor quality. At 80/20 we set high standards for each and every process to make sure you never experience this disappointment with any 80/20 shipment.

At 80/20 we go the extra mile to ensure you get the product you want how you want it. We adhere to rigorous quality checks throughout the entire product lifecycle. This 80/20 difference means that on every order, your parts will be cleaned, and individually packed by type. Hardware and parts will be clearly labeled and packaged with appropriate measures for safe transit.

For orders that you need segmented into kits or bundles, that's not a problem. Receiving your shipment in kit form is especially useful for instances where you have multiple quantities of the same project, allowing for easy organization and setup.



If you are ordering large quantities, our bundling service packages similar products together. For instance, all of your bars will be packed together and all of your panels packed together. As with all orders, they will be clearly labeled. Bundled orders typically have lower freight costs due to their consolidated nature.

When you have an order with specific packing requirements, we can accommodate.

[Visit our Custom Packaging page for more information on special packing and labeling services](#)

Ongoing Support

Your 80/20 support doesn't end when you receive your order. If you have questions or need assembly advice or suggestions, we've got you covered. Our dedication to providing you quality products and services is all-inclusive; we want to partner with you on your entire solution.

You also have access to an extensive network of local distributors able to assist with on-site needs or product information. These knowledgeable specialists work with you to make sure you're completely satisfied with your 80/20 products.

And in the off chance that your order isn't exactly what you expected, we'll make your return simple and painless and expedite the fulfillment of a replacement. Visit our return policy on page 46 and you can always speak to a representative to work through the process with you.

Customer Support

It's important that you get the information, assistance and answers you need when you need them. You don't want to spend time navigating through a stream of prompts or being passed from one person to another.

At 80/20 our phone is answered by a live person who will quickly direct you to the right person. We have extended hours of operation; from 7 a.m. - 6 p.m. ET and if you need afterhours assistance we have personnel available.

If you prefer the convenience of online assistance we offer live chat sessions to accommodate your schedule and provide interactive support. You can expect prompt responses and useful information.

From product questions to order tracking or design assistance, we have an extensive network of support specialists ready to help through a variety of communication channels. Whether you prefer email, phone, or live chats, you'll work with knowledgeable and experienced personnel to get the dedicated attention and information you need in a quick, concise manner.

Contact a Representative today for product information, design assistance, order tracking, or any other questions you may have.

Local Distributor Network

80/20 has an extensive network of local distributors to serve your full-cycle needs. These specialists provide a range of services from on-site demonstrations and evaluations to after-order assistance.

Your local distributor is there for you throughout every stage of the 80/20 experience. Even before you begin designing your solution technicians can visit your business to provide a review of your equipment and processes. You'll find that distributors have "80/20 eyes." They can see places and procedures where 80/20 products and services will help speed up product lifecycles, cut your costs, or create synergies.

Local distributors are also available for recommendations on integrating 80/20 with your current equipment and resources. 80/20 partners with distributors focused on a robust line card able to serve a diverse industry base and accommodate your total-project requirements.

Online Assistance



**LIVE
CHAT**

Distributor Lookup



Use the Distributor Lookup tool to find your local 80/20 partner. For help with any immediate questions contact a Customer Service Representative at 260.248.8030.

Design Assistance: From Concept to Completion

We have highly skilled Design Technicians on-staff to provide you a custom quote and offer optimization recommendations. These experienced technicians will see your solution through from idea to production. We'll help you save costs by finding the best, most economical, option to get the job done.

Our technicians have a great eye for detail and take the time to review your design for accuracy. We'll work with you to address your requirements.

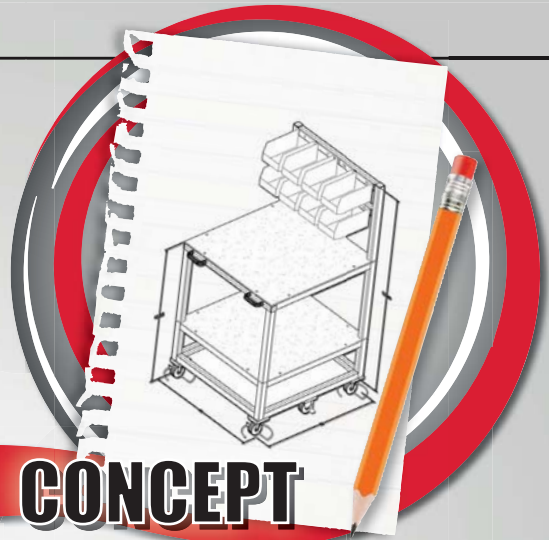

Local Assistance

Our local distributors are also available through an extensive network for added support. 80/20 distributors are the most knowledgeable and experienced in the industry.

No Project Too Big or Too Small

There are no size limits on what we will quote. No design is too big or too small; we appreciate all of your business and want to work with you on any project.

Online Design Assistance Tool

Our online tool makes it fast and straightforward to submit your request for design assistance. Simply fill out the preliminary design sheet and, if applicable, upload your drawing(s).

For additional details or to use the Online Design Assistance Tool visit our website at www.8020.net.



Free Design Tools

80/20 offers several free tools, libraries, and drawing files to make it easy for you to design and enhance your 80/20 project. This variety of resources also make it simple for you to integrate 80/20 products into existing designs. Be sure to check out our YouTube site for helpful hints as well as tips and tricks videos.

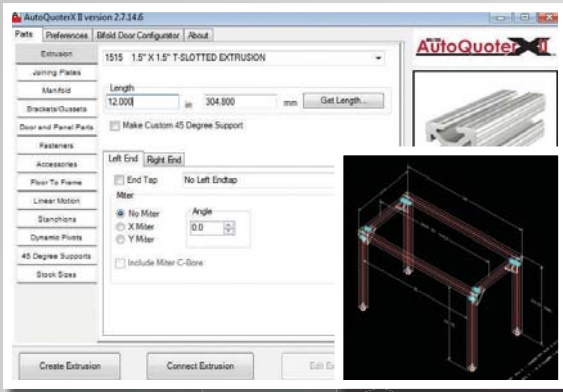

80/20 AutoQuoterX II

AutoQuoterX™ II is used in conjunction with versions of AutoCAD® software for optimum design capabilities. It is free and can be downloaded from our website. This plugin features an easy-to-use interface to streamline the design process and generate a detailed bill of materials. We are continually updating and enhancing AutoQuoterX™ II tools and resources.

80/20[®] Inc. Tech Toolkit

Tech Toolkit™ offers bundled design tools to provide guidance and speed up design time. These tools will help specify the profiles that work best for your application. Use the built-in conversion calculator to cross-reference calculations. There is also a deflection calculator for beam deflection as well as a miter cut worksheet to assist in creating drawings, analyzing real-life limits, and more.

Mechanical Calculators

Select Profile Type: Fractional Metric HT Series Quick Frame Created Beams

Profile Part Number: 1003

Profile Length: 25.23 in / 640.94 mm

Maximum Length of Profile: 242 in / 6146 mm

Profile Load: 400.21 lbs / 181.53 kg

Profile Weight / Foot: 0.5333 Lbs / 0.241900 Kg

Cross Sectional Area: 0.4582 Sq. In. / 2.956123 cm²

Moment Of Inertia X: 0.0441 in⁴ / 1.835580 cm⁴

Moment Of Inertia Y: 0.0491 in⁴ / 2.043696 cm⁴

Yield Strength: 30000 Lbs / Sq. In. / 241.3 N/mm²

Modulus Of Elasticity: 10200000 Lbs / Sq. In. / 70326.5 N/mm²

Deflection (Fixed One End)	Deflection (Fixed Two Ends)	Deflection (Supported Two Ends)
<p>Calculate Deflection</p> <p>Load Every Distributed</p> <p>Deflection X: 1.7911 in / 45.432939 mm</p> <p>Deflection Y: 1.6057 in / 40.56203 mm</p>	<p>Deflection X: 4.3221 in / 109.78133 mm</p> <p>Deflection Y: 3.882 in / 98.6023 mm</p>	<p>Length From Left: 4 in / 101.6 mm</p> <p>Length From Right: 21.23 in / 539.24 mm</p> <p>Deflection X: 0.1706 in / 4.33324 mm</p> <p>Deflection Y: 0.1532 in / 3.89128 mm</p>

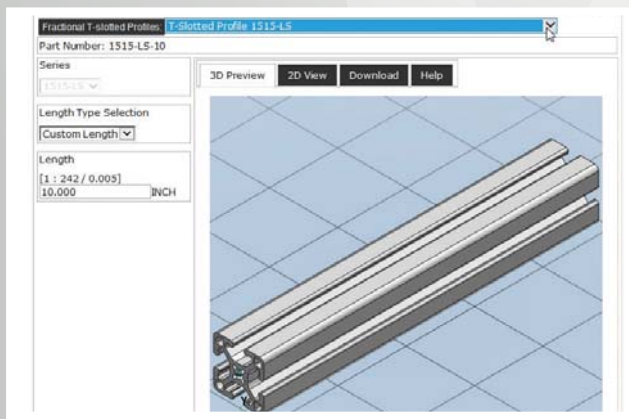

80/20 PARTSOURCE™

CAD File Library Powered By PARTSolutions®

80/20's PartSource™ is a CAD library powered by PARTSolutions® and is accessible directly from our website. It includes design files for parts and profiles. Products are available in both 2D and 3D file types, supporting a variety of CAD packages. Users of Inventor® also have the added benefit of a direct link to PartSolutions™.

SolidWorks® 2010 - Dynamic Library

The 80/20 SolidWorks® Dynamic Library is a free single download of thousands of parts, including profiles, fasteners and accessories. This simple download makes it easier for you to design, test, and experiment with your builds. We are continually adding drawing files, so be sure to check for updates at 8020.net.

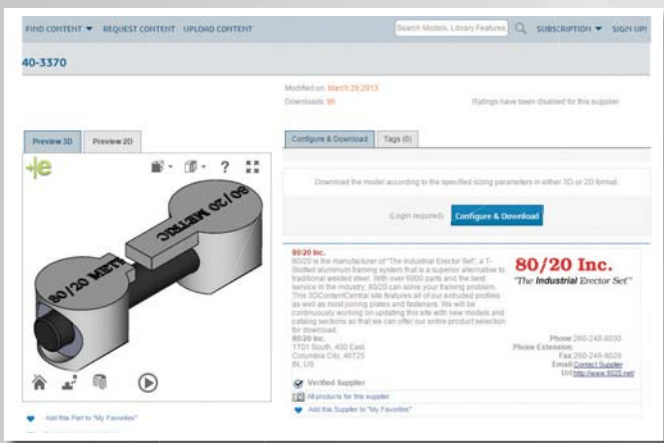

3D Content Central® provides easy to find 2D and 3D file types for 80/20 profiles, fasteners and accessories. The files support a wide range of CAD packages. Users of SolidWorks® have the added benefit of a direct link to 3D Content Central.

CAD DIRECT



Free Streamlined Files

80/20 offers free streamlined files for T-slot, Ready Tube™ and Quick Frame™ profiles. Each profile series is downloadable in its own convenient file. The files are available in:

- AutoCAD® - DXF – 2D
- SolidWorks® 2013 – SLDPRT
- Inventor® - IPT File Format
- SketchUp – SKP File Format

Visit 8020.net to use all of 80/20's design tools!



Time is critical in today's fast-paced world. 80/20 Builds assembly service gives you more time to focus on what you do best. We'll take your project from the design stage all the way through completion, including the actual assembly.



80/20 **BUILDS**
YOU DREAM IT, WE BUILD IT

It stands to reason that, on average, we can assemble your project in about a quarter of the time it takes someone who doesn't build with 80/20 day in and day out. Consider all the other projects and tasks that can be done in that time!

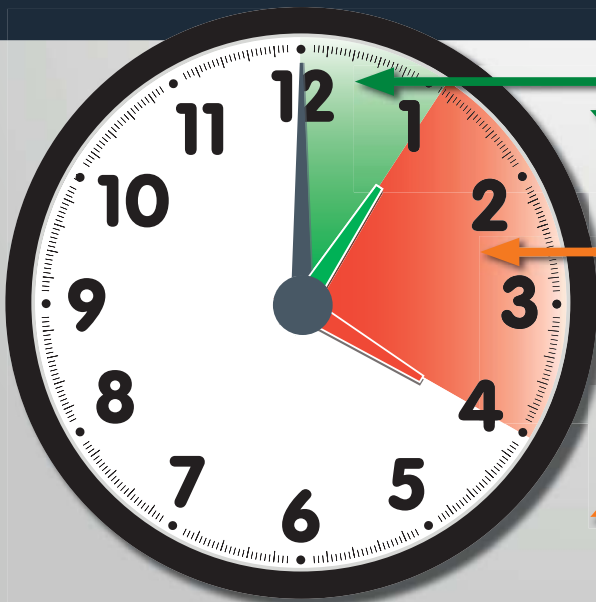

80/20 BUILD TIME

80/20's experience with the product along with our specialized tools and large work area enable us to be the fastest and most efficient at building with 80/20.

1 HOUR

YOUR BUILD TIME

We know there are occasions when space, personnel, or time constraints make it difficult to devote resources to assembling a project.

4 HOURS

ADVANTAGE OF THE 80/20 EXPERIENCE

The 80/20 Builds service was created to help you increase your productivity. We have a team comprised of dedicated and experienced technicians that optimize designs, build projects and ship them safely and damage-free. Our tools and resources ensure precise assembly to your exact specifications.



See how 80/20 Builds Service can help save you time in this video of an 80/20 Builder in action.



THREE SERVICE OPTIONS

You have three service options to choose from with 80/20 Builds: preloading, subassembly, or full assembly.

PRELOADING



We prep your fasteners and plates with the required hardware for quick installation.

SUB-ASSEMBLY



We build your project into segments that can be easily and quickly assembled later.

FULL-ASSEMBLY



Your project is completely built, shipped, and ready to use when it arrives at your door.



Custom Machining

Our Custom Machine shop is another way 80/20 provides your solution from concept to creation. This in-house service means we can be your one-stop-shop for T-slot systems as well as custom parts, accessories, and attachments to complete your entire project.

Our precision in-house Custom Machine shop quickly makes adjustments or changes to any part in our catalog, saving you the headache involved in outsourcing these services. We can also make an entirely new piece completely customized for your needs. And if it's not a material we carry, we'll source it for you.



VAST STOCK OF PARTS

We offer over 200 in-stock structural shapes; 80/20 will make the custom bracket or mount you need to augment your order. Don't waste time and energy working with multiple vendors. We have the materials, personnel and equipment to provide your products with a quick turnaround and the high level of quality that comes with all 80/20 products and services.

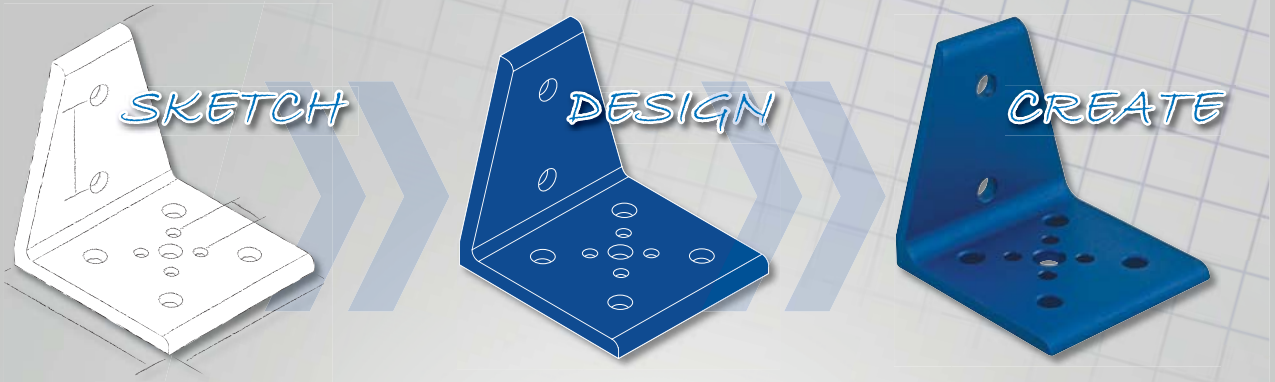

NO PART TOO BIG OR TOO SMALL

We specialize in custom-machining aluminum; there are no minimum charges and no minimum runs. Our state-of-the-art equipment is set up for single parts or large quantities, all to the tightest of tolerances.

Contact a Design Technician today at 260.248.8030 for assistance with your Custom Machining project.



Did You Know?

Every year, 80/20 machines over 100,000 custom parts, panels and aluminum profiles.





PANEL SHOP

80/20's in-house Panel Machine Shop is a service that provides you the total solution for your project needs. We stock a selection of over 100 varieties of plastic panels, aluminum plates, and wire mesh with thicknesses ranging up to half an inch. This huge supply means you won't have to wait on material or the machining; we do it all in one location.

We machine our panels in-house, saving you valuable time and money; you'll get your project fast and to your exact requirements.

VARIETY OF PANEL TYPES

- Acrylic
- Polycarbonate
- Kydex®
- HDPE Pegboard
- HDPE
- ESD
- Expanded PVC
- Alucobest™
- Alupalite™
- Wire Mesh
- AR Polycarbonate
- Recycled Polycarbonate
- Solid Aluminum Plate
- Diamond Tread Plate
- Laminated Tabletop
- Twin Wall Polycarbonate
- Expanded Metal
- Phenolic Resin
- ABS Haircell
- Thermoplastic Coated Wire Mesh



CUSTOMIZE YOUR PANEL

We have the equipment to take your design and create the custom shape, access point, door, or barrier your project may require. The results of this extensive in-house shop are finalized materials that are seamlessly incorporated into your application.

This is accomplished at the high level of quality we hold ourselves accountable to in all of our products and services. From the initial design stages through our hand-packing procedures, you'll receive your panel just as you ordered it and expect it – to your specifications and damage free.



Panel Shop Machining

- Cut to Size
- Custom Designs
- Engraving
- Lettering
- Recessing
- Perforating
- Notch for Hardware
- Much More!



METAL FINISHING

Our in-house metal finishing capability is one of the several ways 80/20 is committed to being your one-stop-shop for T-slot projects. This service encompasses a range of options to provide you with fast turn times and consistent, high-quality, products.

Our standard finishing process here at 80/20 begins with the raw aluminum product; we machine the part, vibratory finishing and/or sand it (depending on the item), and then move it into the anodize finishing process. It's worth noting that 80/20 is one of the only T-slot providers in the industry with in-house anodizing capabilities.

PROVIDING HIGH QUALITY

We have invested in the resources to provide a high-quality product in a timely manner. Our metal finishing shop consists of dedicated personnel, equipment and space.

And we know that there are times you need an alternative finish for your product. Talk to a technician today; we also offer a range of special finishes from powder coating to electroplating and beyond.



Finishing Options

- Mill
- Anodize
- Blasted
- Chromate
- Zinc Plating
- Powder Coat
- Electroplating



STANDARD MACHINING



Did You Know?

80/20 has over 500 standard machining services available to provide fast turn times.

80/20 has a wide range of standard machining services. These are cuts, drills and bores we make hundreds of times a day to your precise specifications. We have invested in top-of-the-line equipment and personnel to create a streamlined process for machining your products fast and accurately.

We have this down to a science; our large selection of standard machining services applies to all of our profiles, fasteners and accessories. We even have panel, wire mesh, and aluminum plate machining capabilities. This means high-quality, accurate products coupled with fast turn times.

PROVIDING HIGH QUALITY

If you need one or one hundred parts machined, we have the capabilities to accommodate. Our equipment ensures precise cuts and drills so you receive your order just as you designed it. What's more, each part is visually inspected and measured for proper location and sizing of machining services.

*"We are what we repeatedly do.
Excellence, then, is not a single act, but a habit."*

~ Aristotle



CUSTOM PACKAGING

When you need something beyond 80/20's standard packing for your order, we offer a custom packaging service. This service accommodates your more detailed and specific requirements. From bubble wrapping each profile, using unmarked boxes or labeling parts per your special instructions, we will work with you to fulfill your packing needs.

FOR YOUR SPECIFIC NEEDS

A popular option is our part-tagging service. This is ideal for orders with several bars of varying lengths or different machining services, or for large quantities that you need labeled alphanumerically to match the bill of materials. The parts will be separated and packaged together by type and the labels will be clear and easy to read.

As with all 80/20 orders, our packing is to the highest of standards. No matter the unique details of your requirements, your shipment will be properly hand-packaged to ensure a damage-free delivery.



Popular Custom Packaging Options

- Part-tagging
- Bubble Wrapping
- Individual Part Packing
- Unmarked Boxes
- Kit Packaging
- Bar Coding

Shipping Schedule

Many of 80/20 orders ship the same day and even more ship in 24 hours. Our standard shipping time is the best in the T-slotted profile business.

Consider the following when deciding whether to buy pre-cut or full length profiles:

- **Freight costs and delivery schedules**

Packages longer than 100" must ship via commercial carrier. Any package 100" or shorter can ship via UPS, which is usually substantially less expensive and has faster delivery schedules than commercial trucking.

- **Quality cuts and accurate lengths**

When you purchase pre-cut profiles, you can expect to receive quality cuts and accurate lengths, washed and packed for shipping. 95% of these orders ship complete the same day.

- **80/20® is centrally located for convenient UPS delivery from coast to coast**

Shipping Rate Information:

Most carrier rates are calculated based on weight. However, since most trailers reach their volume capacity before their weight limit, the important factor is the volume of the shipment. Standard rate classifications for 80/20® packaged profiles and panels start at rate class 60. This classification may vary due to the finished package size.

Aluminum Profile:

Freight Rate Classification: ≥ 60

Bill of Lading Description: aluminum profiles and parts

Plastic Panels:

Freight Rate Classification: ≥ 85

Bill of Lading Description: laminates in sheets

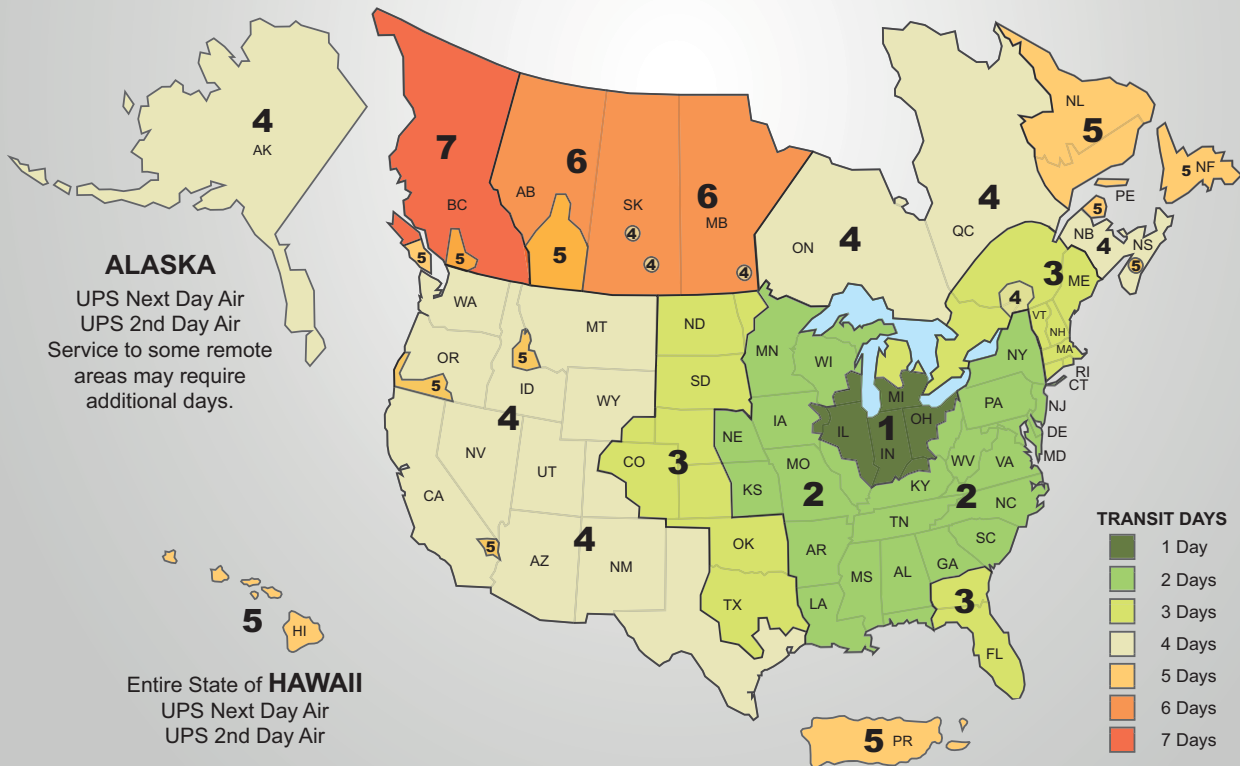

ALASKA

UPS Next Day Air
UPS 2nd Day Air
Service to some remote areas may require additional days.

Entire State of **HAWAII**

UPS Next Day Air
UPS 2nd Day Air

PUERTO RICO

UPS Next Day Air
UPS 2nd Day Air

Shipping Schedule

You need communication, commitment and timely delivery of your orders. Superior quality, customer service, and fast shipping are the foundation of our business so we will always strive to ship your orders in less than our published timeframes. Assuming that your order is ready for processing (including all drawings and worksheets) the shipping schedule chart outlines when you can expect your order to be shipped.

Order Type	1 Day	2 Days	Scheduled
<ul style="list-style-type: none"> • Parts only • Cut to length T-slotted profiles (with or without parts) • Stock length/size on bars & panels (with or without parts) • Cut to length mill-finish structural shapes 	A		
<ul style="list-style-type: none"> • Parts, panels, and T-slotted profiles with standard machining in addition to cuts (our standard kit orders) 		B	
<ul style="list-style-type: none"> • 80/20 Builds orders • Custom Machining orders • Orders requiring custom packaging • Anodized (except black and clear) or outsourced parts • Non-Preferred Carriers (2 days will be added to the normal shipping schedule) 			C

Preferred Carriers

To ensure timely and safe delivery of your products 80/20 works with preferred carriers. These carriers understand and have committed to our high level of quality and customer service. They make daily scheduled pick-ups. If you have a transportation company you prefer to use and they are not on this list, we will work with you to accommodate.

Less-Than-Truckload (LTL) Carriers:

- UPS Freight
- YRC Freight
- Conway (XPO)
- Old Dominion
- ABF Freight

Parcel Carriers:

- UPS Ground
- FedEx Ground

Return Policy

1. Contact your 80/20 distributor or 80/20 Inc. for an RGA (Returned Goods Authorization) packaging form.
2. Write the RGA number on the packing list AND shipping label of your return carton. Full credit is given for undamaged, unused stock parts
3. Carefully wrap and pack all parts you're returning to prevent damage (and possible credit refusal) during shipping.

Damaged or Lost Shipments

UPS and Prepaid Truck Shipments:

Check your order immediately upon receipt. All damages must be noted on the packing slip and bill of lading. All shipping discrepancies must be reported to 80/20 Inc. within 14 days of receipt of your order. Keep all damaged goods for inspection.

Truck or Expedited Freight (when you select the carrier):

Check your order immediately upon receipt. All damages must be noted on the packing slip and bill of lading. All shipping damages, discrepancies and shortages must be reported to the carrier you selected within 7 days of receipt of your order. Keep all damaged containers and goods for your carrier to inspect. File your claim with your carrier for the damages at that time.

Warranty

Our Philosophy

80/20®'s warranty is simple. If you're not happy with the quality of our products or service, we're not happy either. Our goal is to be your one source for T-slotted aluminum profiles. We want to hear your comments, good or bad.

We guarantee your satisfaction!

Our Attorney's Philosophy

All 80/20® products are guaranteed to be free of actual defects in material and workmanship, provided any such defect be reported to 80/20® in writing within one (1) year of shipment from factory. This warranty is limited to replacing or repairing, at 80/20®'s option, F.O.B. 80/20® factory, any part which, upon 80/20® inspection is found to have a defect in material and/or workmanship. 80/20® in no event shall be liable for indirect or consequential damages arising out of the use of 80/20® products. Components purchased by 80/20® from others for inclusion by 80/20® shall be warranted only to the extent set out above and/or to the guarantee or warranty, if any, made by the supplier of said component.

No warranty is made by 80/20® express or implied, that 80/20® products as used in a customer's design and specifications are fit for that customer's specific purpose. APART FROM THE ABOVE EXPRESS WARRANTY, THERE ARE NO WARRANTIES, EXPRESS, IMPLIED, OR STATUTORY, INCLUDING, WITHOUT LIMITATION, WARRANTIES OF MERCHANTABILITY AND FITNESS FOR A PARTICULAR PURPOSE, WHICH EXTEND BEYOND THE DESCRIPTION ON THE FACE HEREOF.

80/20® expressly reserves the right to substitute materials in the products described in the catalogs and any supplements thereto; however, this shall not apply to special order products and/or custom products where 80/20® is advised in writing of specific material requirements and agrees in writing to comply with the requests for such specific materials.

Any and all warranties shall be construed and enforced under the Laws of the State of Indiana.

Terms and Conditions of Sale

- ORDER PLACEMENT.** All goods and services furnished by 80/20, Inc. ("80/20") are provided pursuant to these Terms and Conditions ("Terms and Conditions") whether provided following an order placed electronically, verbally, or on paper, whether the order is placed directly through 80/20 or through an 80/20 representative, and whether the order is placed following Buyer's review of 80/20's catalog or website, or following receipt of a Quotation only, or following the exchange of other documents (the catalog website Quotation and all other documents, hereafter, jointly, the "Quotation"). Acceptance by 80/20 of Buyer's order is expressly conditioned upon Buyer's acceptance of these Terms and Conditions, including those on the face of the Quotation, and any provisions of Buyer's order in conflict with these Terms and Conditions are expressly rejected. Buyer acknowledges that no representation or warranty other than those contained in this document have been made or relied upon. No additions or modifications shall be valid unless confirmed in writing by 80/20. **80/20 IS NOT BOUND TO FURNISH ITS GOODS OR SERVICES EXCEPT IN ACCORDANCE WITH THESE TERMS AND CONDITIONS.**
- PRICE/DELIVERY/DELAY.** Prices for goods shall be those in effect on the date of invoice unless otherwise provided by the Quotation or agreed to in writing by 80/20. Unless otherwise provided on the face of the Quotation or agreed by 80/20 in writing, price, price and delivery terms shall be F.O.B. shipping point. Unless otherwise agreed in writing, 80/20 will select the route and manner of shipment, reserves the right to make delivery in installments when necessary, to invoice each installment separately, and to expect payment for each installment within 80/20's selling terms. All risks of loss or damage shall pass to Buyer at the place and time such goods are placed into the possession of the carrier or shipper, in accordance with the previously referenced F.O.B. shipping point term. Buyer shall be responsible for obtaining and paying for insurance to cover any loss to Buyer. Buyer shall pay 80/20 for the contract price in the event of loss of the goods. If Buyer fails to accept delivery according to the agreed upon delivery schedule, 80/20 may cancel the then remaining balance of the order. Such cancellation, if elected by 80/20, shall be in addition to, and not in lieu of, any other rights or remedies which 80/20 may have at law or equity. Prices are good for only quantities indicated. If shipment or any other act or condition affecting payment for the goods or any part of them shall be delayed on account of Buyer, payment shall be due as if shipment had been made, a reasonable storage charge may be made, and such storage shall be at the risk of Buyer. 80/20 shall not be liable for any direct, indirect, consequential, special, or incidental losses or damages to Buyer or to any third parties resulting from 80/20's delay in shipment regardless of cause, including but not limited to those causes set forth in the Force Majeure section of this document.
- CHANGES IN SPECIFICATIONS OR DESIGN.** If Buyer requests any change in quantity, specification or design relating to any goods or services, or changes of delivery date and/or schedules, such proposed change shall be subject to the terms and conditions of this Quotation and must be approved in writing to be binding upon 80/20.
- PRODUCT VARIANCE FROM PHOTOS.** 80/20 attempts to provide accurate photographs of the products it offers for sale, but there may be some variation between the photographs and the actual products. Buyer may return any product if the variance is unacceptable to Buyer. Buyer must submit its request for return based on the product variation within thirty (30) days after receipt of the goods.
- ACCEPTANCE.** Goods furnished or services performed by 80/20 will be deemed to have been finally accepted thirty (30) days after receipt by Buyer, unless rightfully rejected within such period by written notice to 80/20, setting forth all of the defects upon which the rejection is claimed. Claims for factory damage or shortages shall not be considered unless made in writing within thirty (30) days after receipt of the goods or services and accompanied by reference to our bill of lading and invoice numbers. Buyer's claims for damage or shortage in transit must be filed by Buyer against carrier. Defective goods shall be held for 80/20's inspection or disposition. Buyer must note damaged goods or the appearance of probable damage with the freight carrier and on the relevant freight documents at the time of receipt.
- 80/20 PROPERTY.** All photographs, samples, descriptions, drawings or intellectual property provided by 80/20 to Buyer (collectively, "80/20 Content") shall remain the property of 80/20 and shall only be used by Buyer to market 80/20 products to third parties. Buyer shall include in any materials provided by 80/20 to Buyer incorporating 80/20 Content, all copyright and trademark notices and any other indications of ownership of the 80/20 Content. All use of 80/20 Content by Buyer shall cease and all 80/20 Content shall be returned to 80/20 upon demand by 80/20 and any license created hereunder, implied or otherwise, is terminable at will by 80/20 and is hereby expressly terminated pursuant to Section 18 upon termination of this agreement. Upon demand by 80/20 Buyer shall immediately take down and remove access to all 80/20 Content, including all 80/20 Content posted on third-party sites at the direction of, or due to the actions of Buyer. If Buyer fails to immediately secure such take downs and removals, 80/20, acting as Buyer's agent, may make such application for such take downs and removals on behalf of Buyer and in Buyer's name and in such event Buyer shall render every assistance to 80/20. Buyer hereby appoints 80/20 as Buyer's agent for this purpose. Further, Buyer agrees that 80/20 shall be entitled to equitable relief from Buyer, including but not limited to a restraining order or other injunctive relief against Buyer, to obtain compliance if Buyer fails to comply with any provision of this Agreement. 80/20 shall also be entitled to remuneration for the resources expended to take down and remove any such 80/20 Content, including reasonable attorney's fees.
- RETURN POLICY.** Buyer shall have no right to return any goods furnished by 80/20, 80/20 may, in its sole discretion, authorize Buyer to return goods. 80/20 may authorize the return of goods without charging a restocking charge, but in most cases, 80/20 will only authorize the return of goods subject to a restocking charge, the amount of which will depend on the type of goods being returned. The restocking charge shall be deducted from the amount refunded to Buyer.
- TAXES.** Prices do not include any federal, state or local taxes. Any applicable excise, import, sales, use or similar taxes, whether federal, state, provincial or local, and any transportation and other charges shall be the responsibility of and be paid by Buyer and, if paid by 80/20, Buyer agrees to reimburse 80/20 for any such payment and further agrees that 80/20 may add any such payments to the purchase price of the goods.
- PAYMENT/CREDIT/SECURITY.** Payment shall be due prior to shipment unless adequate credit remains on an account in good standing. All orders received are subject to credit approval. Buyer agrees to submit from time to time to 80/20 those items reasonably requested in order to establish or update Buyer's credit. 80/20 shall be entitled to charge interest on past due accounts at a rate of 1.5% per month (18% annually). Whenever 80/20, in good faith deems itself insecure, it may, without prejudice or waiving any other rights or remedies it may have at law or equity, cancel any outstanding orders, any unfiled orders; modify or revoke its extension of credit to Buyer; and take any other steps permitted by law and necessary or desirable to secure 80/20 with respect to Buyer's payment of goods and services furnished or to be furnished. Buyer will pay 80/20's actual costs of collection, including but not limited to court costs, litigation expenses, and reasonable attorney's fees, incurred for collection of any delinquency. Title to the goods shall remain with 80/20 until Buyer receives physical possession of the goods and the goods are fully paid for by the Buyer. Buyer shall have no right of offset against amounts owed to 80/20.
- LIMITED WARRANTY/REMEDY.** All 80/20® products are guaranteed to be free of actual defects in material and workmanship, provided any such defect be reported to 80/20® in writing within one (1) year of shipment from factory. This warranty is limited to replacing or repairing, at 80/20®'s option, F.O.B. 80/20® factory, any part which, upon 80/20® inspection is found to have a defect in material and/or workmanship. 80/20® in no event shall be liable for indirect or consequential damages arising out of the use of 80/20® products. Components purchased by 80/20® from others for inclusion by 80/20® shall be warranted only to the extent set out above and/or to the guarantee or warranty, if any, made by the supplier of said component. No warranty is made by 80/20® express or implied, that 80/20® products as used in a customer's design and specifications are fit for that customer's specific purpose. Services performed by 80/20 will be conducted in a manner consistent with that level of care and skill ordinarily exercised by members of the industry currently practicing under similar conditions. As an independent contractor of Buyer, 80/20 will provide evaluation, advice, and guidance to Buyer, but Buyer recognizes that 80/20 is a technical contractor and not a professional consultant.
APART FROM THE ABOVE EXPRESS WARRANTY, THERE ARE NO WARRANTIES, EXPRESS, IMPLIED, OR STATUTORY, INCLUDING, WITHOUT LIMITATION, WARRANTIES OF MERCHANTABILITY AND FITNESS FOR A PARTICULAR PURPOSE, WHICH EXTEND BEYOND THE DESCRIPTION ON THE FACE HEREOF.
80/20® expressly reserves the right to substitute materials in the products described in the catalogs and any supplements thereto; however, this shall not apply to special order products and/or custom products where 80/20® is advised in writing of specific material requirements and agrees in writing to comply with the requests for such specific materials. Any and all warranties shall be construed and enforced under the Laws of the State of Indiana.
- INDEMNIFICATION.** Buyer shall defend, indemnify and hold 80/20 harmless from and against any and all claims, liabilities, loss, costs, damage or expense (including reasonable attorneys' fees) of any kind or nature whatsoever relating to the performance by 80/20 hereunder, including without limitation, claims made for property damage or personal injury (including death), whether such claims are premised on contract or on tort (including, without limitation, strict liability). This indemnity provision shall not apply where such damage or injury is attributable solely to the negligence of 80/20, its employees or agents.
- FORCE MAJEURE.** 80/20 will not be liable for any delay in the performance of its obligation under this Quotation or for any damages suffered by the Buyer by reason of such delay, when such delay is directly or indirectly caused by or in any manner arises from: fires; floods; accidents; riots; acts of God; governmental interference, embargoes; strikes; labor difficulties; shortages of labor, fuel, power, materials or supplies; transportation delays; any existing or future laws or acts of the Federal or any State government (including specifically, but not exclusively, any orders, rules or regulations issued by any official or agency or any such government) affecting the conduct of 80/20's business; or any other cause or causes (whether or not similar in nature to any of those specified above) beyond 80/20's control, including but not limited to modifications to the fabricating specifications requested by the Buyer subsequent to commencement of production by 80/20.
- NO WAIVER.** The failure of 80/20 upon knowledge of any default or violation by Buyer of any of the Terms and Conditions of this Quotation, or any sales agreement entered into hereafter, to enforce its rights or remedies shall not be construed as a waiver of such default or violation, or of any provision hereof, or of any of its rights or remedies.
- LIMITATION ON LITIGATION/ATTORNEY FEES.** Any controversy or claim of Buyer arising out of or related to any transaction with 80/20 must be commenced within one (1) year after the cause of action has accrued. 80/20 shall be entitled to reimbursement of all costs and expenses, including reasonable attorneys' fees, from the Buyer relating to any lawsuit in which 80/20 prevails in any amount or on any claim.
- ENTIRE AGREEMENT/LAW AND FORUM/SEVERABILITY.** Except as otherwise agreed in writing or if another writing incorporates these terms hereby making these terms supplemental to such writing, this constitutes the entire agreement between 80/20 and Buyer, superseding all prior Quotations and understandings, oral or written. All such previous communications are hereby aggregated and withdrawn, and no stipulations, representations or agreements by 80/20, or its officers, agents, or employees shall be binding upon 80/20 unless reduced to writing and attached to and incorporated by reference herein, and no local, general, or trade custom shall alter or vary the terms hereof. Any questions, disputes, controversies, or litigation between 80/20 and Buyer, including but not limited to disputes concerning the validity, interpretation, or effect of the Quotation, or interpretation and enforcement of the rights and obligations of the parties hereunder, shall be governed by the laws of the State of Indiana and the exclusive venue for resolving any such questions, disputes, controversies, or litigation shall be a state or federal court located in Allen County, Indiana. If any provision of this Quotation is determined invalid under applicable law, such invalidity shall be limited to such provision without invalidating the remainder of the other Terms and Conditions hereof; and if any provision of this Quotation is found to be ambiguous or in conflict with any other provision of this Quotation, such ambiguity or conflict shall be resolved in the manner which provides the greatest protection and limitation of liability to 80/20.
- INSURANCE.** 80/20 will maintain Workers' Compensation insurance coverage at such levels as are required under the laws of the State of Indiana. 80/20 will purchase and maintain comprehensive general liability insurance against claims for personal injury or death or damage to property which may arise out of, or result from, 80/20's performance of the services in such amounts as 80/20 maintains in its ordinary course of business.
- LIMITS OF LIABILITY.** 80/20 will not be liable for any punitive damages or legal fees or any special, indirect, or consequential damages (including but not limited to loss of use or loss of profit) or fees which arise out of the performance of the services by 80/20. 80/20 and Buyer agree that absolutely no action arising out of the services may be brought by either party more than one year after substantial completion of the services. The entire liability of 80/20, or its officers, directors, agents, or employees, and Buyer's exclusive remedy for performance or nonperformance of the services shall be the adjustment or correction of the services by 80/20. If after repeated efforts, 80/20 is unable to adequately perform, Buyer shall be entitled to recover a pro-rata credit for the sums actually paid for the defective portion of the services.
- TERMINATION OR CANCELLATION.** Either party may terminate the services and all obligations arising under the proposal for the reason of the failure by the other party to comply with its obligations upon 30 days prior written notice to the other party. In the event of such termination, Buyer will pay to 80/20 all amounts which are due and payable to 80/20 for the services performed through the date of such termination. In addition, in the event the services are terminated as the result of the failure of Buyer to perform its obligations, Buyer will pay to 80/20 a termination charge of 20 percent of the cost of the remaining services to be performed by 80/20.



A Whole New Way to Look!

The Bookshelf holds the interactive 80/20 Catalog as well as all of the Made with 80/20® flipbooks.

Find parts, pieces and information fast with user-friendly capabilities that allow you to search by part number, name, word, or even by series.

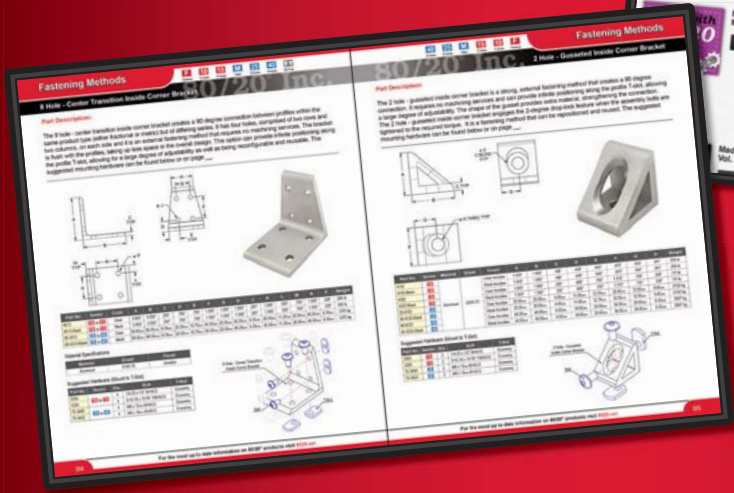
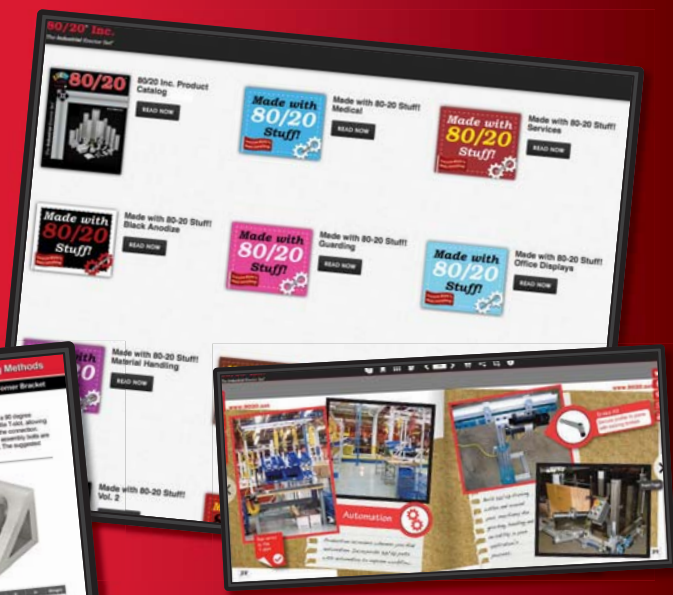

Make A Wish List

Add products to your personal wish list and then save it. Once created you'll have the option to easily click to order.

Check Out Our New Literature!

Download or request copies of our newest releases, such as the Modular Mind Magazine, Solutions books and flipbooks. We're adding to the bookshelf often, so be sure to check back.

For current product pricing, you can even download a digital price list.



Pictorial Table Of Contents



T-Slot Concept Basics

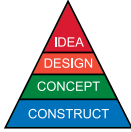

Page 54

Advantages of T-Slot Profiles

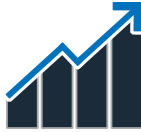

Page 55

Profile Family Types



Page 56

Aluminum Profile Shape Types



Page 57

T-Slot Profile Series Standards



Page 58

T-Slot Profile Quick Reference



Page 66

10 Series T-Slotted Aluminum Profiles



Fractional



10 Series

1010-S Profile



Page 74

1010 Profile



Page 75

1001-S Profile



Page 76

1001 Profile



Page 77

1002-S Profile



Page 78

1002 Profile



Page 79

1003-S Profile



Page 80

1003 Profile



Page 81

1004-S Profile



Page 82

1004 Profile



Page 83

1012-S Profile



Page 84

1012 Profile



Page 85

1050 Profile



Page 86

2012 Profile



Page 87

1020-S Profile



Page 88

1020 Profile



Page 89

1030-S Profile



Page 90

1030 Profile



Page 91

2020-S Profile



Page 92

2020 Profile



Page 93

2040-S Profile



Page 94

2040 Profile



Page 95





















CONTINUE



Pictorial Table Of Contents

15 Series T-Slotted Aluminum Profiles F Fractional 15 15 Series

PROFILES



1515-ULS Profile  Page 96	1515-UL Profile  Page 97	1515-LS Profile  Page 98	1515-Lite Profile  Page 99	1515-S Profile  Page 100	1515 Profile  Page 101	1501-LS Profile  Page 102
1501 Profile  Page 103	1502-LS Profile  Page 104	1502 Profile  Page 105	1503-LS Profile  Page 106	1503 Profile  Page 107	1504-LS Profile  Page 108	1504 Profile  Page 109
1547 Profile  Page 110	1517-LS Profile  Page 112	1517 Profile  Page 113	1575 Profile  Page 114	1534-Lite Profile  Page 115	3075 Profile  Page 116	3034-Lite Profile  Page 117
1530-ULS Profile  Page 118	1530-UL Profile  Page 119	1530-LS Profile  Page 120	1530-Lite Profile  Page 121	1530-S Profile  Page 122	1530 Profile  Page 123	1545-S Profile  Page 124
1545 Profile  Page 125	3030-LS Profile  Page 126	3030-Lite Profile  Page 127	3030-S Profile  Page 128	3030 Profile  Page 129	3060 Profile  Page 130	

CONTINUE 

Pictorial Table Of Contents





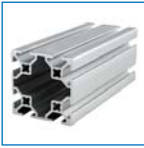



20 Series T-Slotted Aluminum Profiles M Metric 20 20 Series

20-2020 Profile  Page 131	20-2040 Profile  Page 132	20-4040 Profile  Page 133
--	--	--

25 Series T-Slotted Aluminum Profiles M Metric 25 25 Series

25-2525 Profile  Page 134	25-2501 Profile  Page 135	25-2502 Profile  Page 136	25-2503 Profile  Page 137	25-2504 Profile  Page 138	25-2527 Profile  Page 139	25-2514 Profile  Page 140
25-5013 Profile  Page 141	25-2550 Profile  Page 142	25-2576 Profile  Page 143	25-5050 Profile  Page 144	25-5010 Profile  Page 145		

30 Series T-Slotted Aluminum Profiles M Metric 30 30 Series

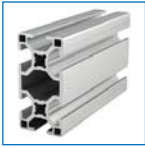
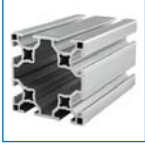
30-3030 Profile  Page 146	30-3001 Profile  Page 147	30-3002 Profile  Page 148	30-3003 Profile  Page 149	30-3004 Profile  Page 150	30-3022 Profile  Page 151	30-3060 Profile  Page 152
30-6060 Profile  Page 153						

CONTINUE



Pictorial Table Of Contents

40 Series T-Slotted Aluminum Profiles M Metric 40 40 Series

40-4040-UL Profile



Page 154

40-4040-Lite Profile



Page 155

40-4040 Profile



Page 156

40-4001 Profile



Page 157

40-4002 Profile



Page 158

40-4003 Profile



Page 159

40-4004 Profile



Page 160

40-4030-Lite Profile



Page 161

40-4093 Profile



Page 162

40-4094 Profile



Page 163

40-4096 Profile



Page 164

40-4045-Lite Profile



Page 165

40-4020 Profile



Page 166

40-8020 Profile



Page 167

40-4080-UL Profile



Page 168

40-4080-Lite Profile



Page 169

40-4080 Profile



Page 170

40-4082-Lite Profile

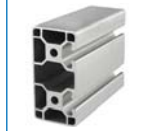

Page 171

40-4083-Lite Profile



Page 172

40-4084-Lite Profile



Page 173

40-4085-Lite Profile



Page 174

40-4012 Profile



Page 175

40-8080 Profile



Page 176

40-8016 Profile



Page 177

45 Series T-Slotted Aluminum Profiles M Metric 45 45 Series

45-4545-Lite Profile



Page 178

45-4545 Profile



Page 179

45-4590 Profile



Page 180

45-9090 Profile



Page 181

CONTINUE

Pictorial Table Of Contents



Ready Tube[™] Aluminum Profiles

RT Ready Tube

Ready Tube Basics

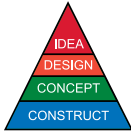

Page 62

Advantages of Ready Tube

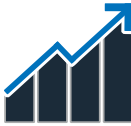

Page 63

Aluminum Profile Shape Types



Page 63

Ready Tube Profile Quick Reference



Page 73

9700 Profile

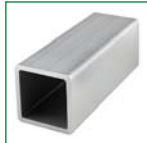

Page 182

9701 Profile



Page 183

9705 Profile

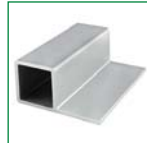

Page 184

9706 Profile



Page 185

9725 Profile

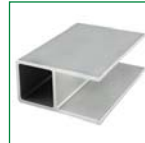

Page 186

9726 Profile



Page 187

9728 Profile



Page 188

Quick Frame[™] Aluminum Profiles

QF Quick Frame

Quick Frame Basics

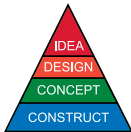

Page 64

Advantages of Quick Frame

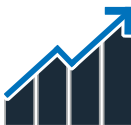

Page 65

Aluminum Profile Shape Types



Page 65

Quick Frame Profile Quick Reference



Page 73

9000 Profile

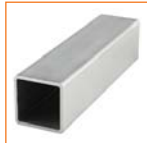

Page 189

9005 Profile

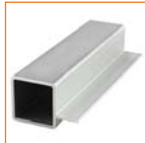

Page 190

9010 Profile



Page 191

9015 Profile

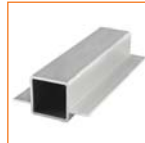

Page 192

9025 Profile



Page 193

9030 Profile

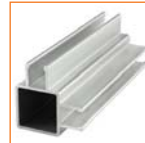

Page 194

9035 Profile

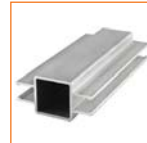

Page 195

Introduction to Aluminum Framing

You have a project or design in mind and now you need to turn that idea into an actual build. Your first step is to choose your profile; T-slotted aluminum profiles, Ready Tube, or Quick Frame. If you would like to head directly to information on Ready Tube, flip to page 62, or to page 64 to read about Quick Frame. Let's begin with the T-slot profile.

The T-slot Concept: Built-in Modularity

T-slot aluminum profiles offer several benefits. The shape of the profile creates modularity, meaning it is easily assembled and reassembled to conform to evolving needs.

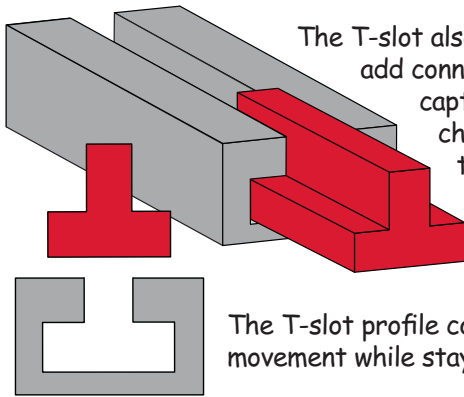

The T-slot also provides the ability to add connections and join profiles to captivated ends. This allows you to change your design without having to start from scratch and also enables easy expansion and retraction of your build for modifications down the road.

The T-slot profile concept is designed to allow movement while staying secure within the T-slot.

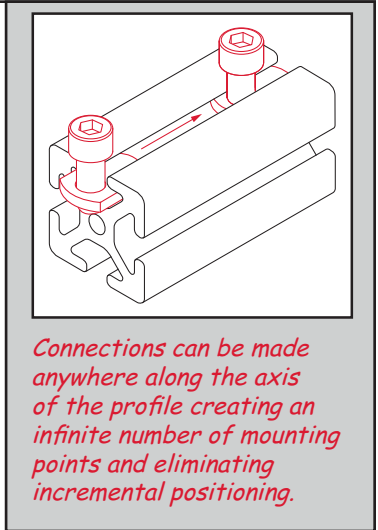

Connections can be made anywhere along the axis of the profile creating an infinite number of mounting points and eliminating incremental positioning.

The T-slot Profile 2° Drop-Lock

Another important attribute of T-slot aluminum profiles is the strong connection made between profiles. 80/20's T-slot aluminum profiles include a 2 degree drop-lock feature for most profiles, which enables connections to remain vibration resistant and strong. 80/20 offers a wide variety of joining options to fit your specific needs (for an overview on fastening products flip to page 204).

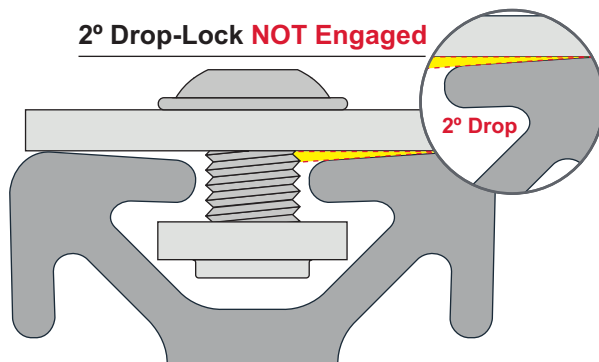

2° Drop-Lock **NOT** Engaged

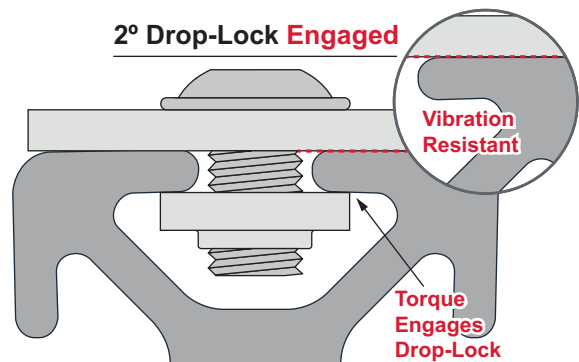

2° Drop-Lock **Engaged**

Advantages of T-slot Aluminum Profiles

Moving on from the T-slot concept, let's consider the benefits of aluminum. There are several advantages to T-slot aluminum profiles. Some of the biggest are:

- Strong
- Lightweight
- High strength-to-weight ratio
- Resilient
- Modularity
- Easily machined

All 80/20 profiles come standard with a clear anodize which helps prevent oxidation and corrosion while providing a matte finish.

The Battle of Aluminum vs Steel

Think about the fact that, volume for volume aluminum is one third the weight of iron, steel, copper or brass. Yet it has yield strength of 35,000 psi, which means it is comparable to A36 steel carbon (frequently used in applications such as equipment and machinery supports as well as building frames). Furthermore, aluminum is resilient and can flex under loads or reshape itself after the shock of impact.



80/20 T-slot Aluminum

Modularity is just a part of the many benefits aluminum offers to those looking for an alternative to steel and iron. Other benefits:

- Weighs less than steel
- Corrosion-resistant
- No welding required
- Costs less than steel
- Strength similar to steel
- Machining not required

Aluminum VS Steel

Welded Steel Frame

For the skilled welder, steel can be a viable option but for many it's not an option for many reasons:

- More time and labor
- More expensive
- Welding required
- Needs painting
- Machining required
- One fixed design



Profile Family Types

FRACTIONAL

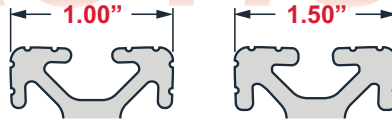

*Profiles are not shown to scale.

The fractional T-slot family uses an inch measurement system (imperial). 80/20 currently offers 56 profiles in fractional units with two standard series; the 10 series and the 15 series. 10 series profiles are based on a 1 inch standard while 15 series profiles are based on a 1.5 inch standard.

Align-a-grooves, featured on our 10 series and some of our 15 series T-slot profiles, aid in aligning and squaring corners and joints during assembly. Align-a-grooves are not available in metric profiles.

METRIC

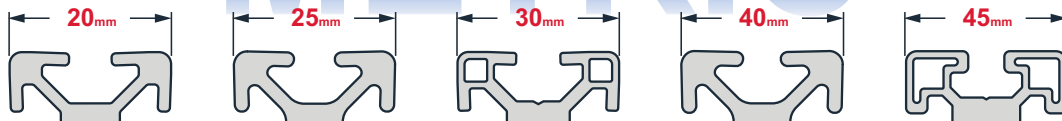

*Profiles are not shown to scale.

The metric T-slot family is measured in meters or millimeters (mm). 80/20 currently offers 51 profiles in metric units with five series; 20, 25, 30, 40 and 45. The dimensions of the metric profiles each coincide with the series; for instance, 20 series profiles are based on a 20mm standard, 25 series are based on a 25mm standard, 30 series profiles are based on a 30mm standard and so on.

After you have decided which measurement system you are going to use, you'll want to decide on a specific profile series. Think about the weight and strength you will need, as well as the shape and open T-slots you want available.

Consider your application and its purpose to help you narrow down your search for the profile that fits your need. 80/20 offers profile series in both the fractional and metric family to accommodate small, medium, and large-scale builds. A prototype project is an example of a small-scale build while a desk or workstation is an example of a medium-scale build. Profiles used for structural framing would be an instance of a large-scale project.

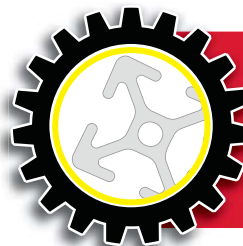

Need to Know

80/20 currently offers both metric and fractional T-slotted profiles with 107 profiles available across seven series types.

The Shape of a Profile

Once you have determined a series that matches the scale of your build, you are ready to choose the shape of your profile. The shape of the profile affects certain properties such as aesthetics and open T-slots. The available shapes are square, rectangle, angled, and radius.



In both the fractional and metric measurement families, 80/20 offers six different square profile shapes. This variety gives you choices to accommodate appearance, accessories and parts. For medium to large-scale applications consider a square profile with eight T-slot openings to allow a multitude of connection points for the addition of profiles and accessories. Some square profiles also include the capability of a pressurized center cavity.

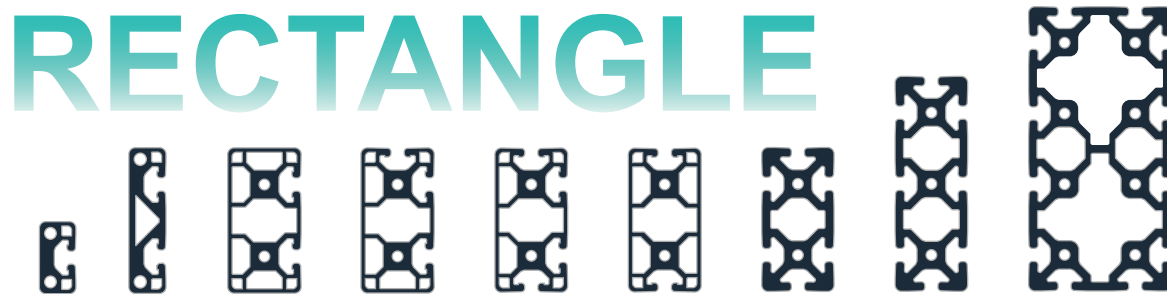

Between the fractional and metric measurement families there are nine rectangle profile shapes and all work well for joining other profiles, parts and accessories. Most rectangular profiles have the capacity for a pressurized center cavity. The twelve-slot rectangle profile is perfect for large-scale purposes, such as load-bearing applications, and offers the most mounting and joining options.



Angled and radius profiles come with 2 open T-slots and are frequently used for panel mounting and exhibits due to their versatility and sleek appearance. The rounded shape of radius profiles works well as hand rails.

To recap, T-slot profiles are extremely versatile, modular and strong. You will first want to choose either the fractional or metric measurement system, and then decide on the specific profile series. From there, narrow down the shape that works best for your build. If you're still not sure which T-slot aluminum profile is right for your project, contact 80/20 at 260.248.8030 or info@8020inc.com for assistance.

Part Number Concept & Identification

Most fractional and metric T-slot profiles have part numbers that directly coincide with the profile's physical measurements. Fractional profile part numbers contain four characters. Metric profile part numbers contain six characters, which relate to the profile's series and dimensions. This series part-numbering concept is explained in more detail below.

Fractional Profile Naming Standards

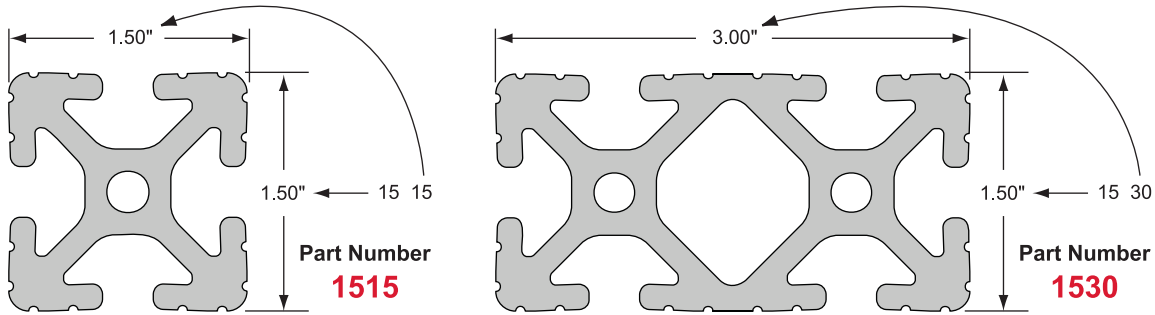

Example: 15 series profiles always measure .75" from the outside edge of the profile to the center of the T-slot.

Metric Profile Naming Standards

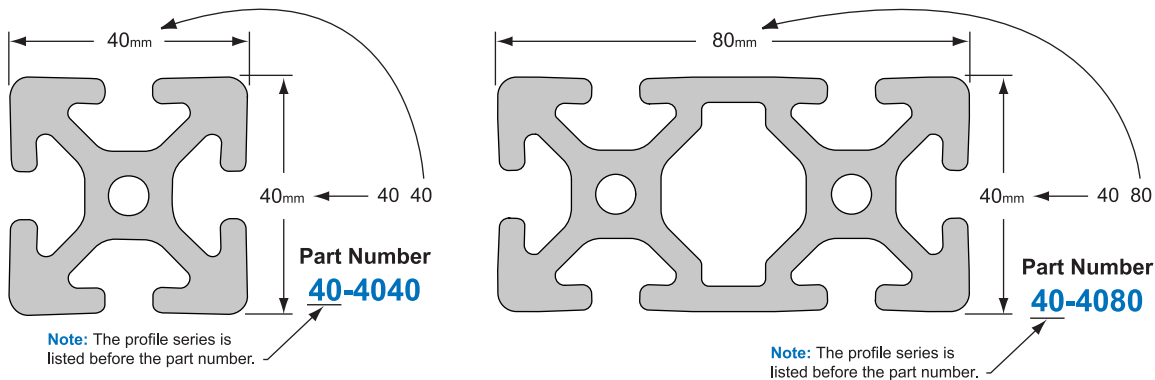

Example: 40 series profiles always measure 20.00mm from the outside edge of the profile to the center of the T-slot.



Basic Concept

The dimensions of your profile usually spell out its part number.

T-Slot Profile Slot Dimensions

80/20 offers over 1,000 black anodized profiles and parts for your custom designs; these are stocked in-house to provide fast and easy access. We use architectural and organic anodizing processes and both meet Military Spec 8625.

You'll find that black anodize makes your projects look sleek while also providing functionality. Black anodize is ideal for low reflective projects, photo booths, military applications, vision systems and anywhere you want to add a polished appearance.



Need to Know

When ordering black anodized products with machining services, these areas will be exposed, meaning not black. If you would like your profiles or parts completely black, including the machined areas, we can accommodate. Contact us for more details.

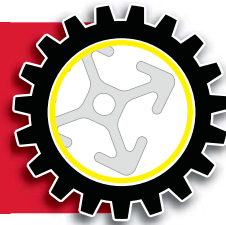

Why 6105-T5* Aluminum Alloy?

All of 80/20's T-slot profiles are made of 6105-T5* alloy, an aluminum extrusion alloy that is a metal mixture which includes other elements such as copper, magnesium, iron, silicon or zinc.

Certain properties such as strength, machinability and corrosion resistance are influenced by the choice of alloy and temper.

Alloy 6105* with a T5 temper has better machinability and strength than 6063-T6.

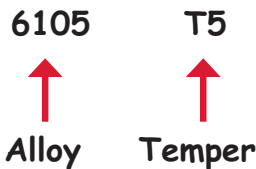

Aluminum Profile Alloys: Number and Characteristics	Tensile Strength - ksi*	
	Ultimate minimum	Yield minimum
6105-T5* (80/20's Alloy)	38.00	35.00
6063-T6	30.00	25.00

Figures based on material thickness of 0.125" to 1.00"
From The Aluminum Extrusion Manual, published by The Aluminum Association and the Aluminum Extruders Council.

Material Strength Specifications

Minimum Yield Strength In Pounds

- 80/20's 6105-T5* alloy yield strength of 35,000 psi compares to A36 carbon steel's yield strength of 36,000 psi.
- Volume for volume, aluminum weighs about 1/3 as much as iron, steel, copper, or brass.

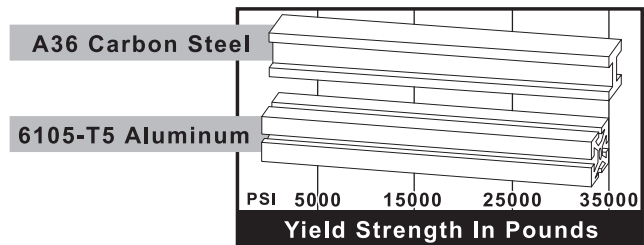

* Or comparable

Simple Beam Deflection Calculations

Formula A

$$\frac{L^3 \cdot W}{48 \cdot E \cdot I} = D$$



This formula will yield worst case deflection for a beam supported at both ends with the load centered over the span.

Formula B

$$\frac{5L^3 \cdot W}{384 \cdot E \cdot I} = D$$



This formula will yield worst case deflection for a beam supported at both ends with the load evenly distributed over the span.

Formula C

$$\frac{L^3 \cdot W}{3 \cdot E \cdot I} = D$$



This formula will yield worst case deflection for a beam fastened at one end and cantilevered horizontally with the load applied at the end of the beam.

Example Using Formula A:

Using the 1515 T-slot profile, a length of 30.00 inches, and an applied force of 50 pounds, you should find the approximate beam deflection to be .011 inches. Using the 40-4040 T-slot profile, a length of 762mm, and an applied force of 222.40 Newtons, you should find the approximate beam deflection to be .21mm.

Formula Reference:

- L = Length in Inches W = Load in Pounds I = Moment of Inertia
 E = Modulus of Elasticity D = Deflection in Inches

T-Slot Profile Specifications

FRACTIONAL		METRIC
35,000 p.s.i. (min)	Yield Strength	241.1 N/mm ² (min)
38,000 p.s.i. (min)	Tensile Strength	262.0 N/mm ² (min)
A5 minimum 10%	Elongation	A10 minimum 8%
10,200 k lb/in. ²	Elasticity E	70,326.5 N/mm ²
Rockwell approximately E-88	Hardness	Brinell approximately 75 HB
.004" per 1 inch of width	Flatness	0.1mm per 25.4mm of width
0.0125 inches per 1 foot of length not to exceed 0.118 inches over 20 feet of length	Straightness	0.32mm per 304mm of length, not to exceed 3mm over 6.1 m of length
Per 1 foot of length not to exceed .25 degree and total twist over 20 feet of length not to exceed 1.5 degrees	Twist	Per 304mm of length not to exceed .25 degree and total twist over 6.1m of length not to exceed 1.5 degrees

Note: Extrusion conforming to DIN 17 615 specifications. Unless otherwise specified, all profiles will have etch and clear (MIL-A-8625F) anodizing with depth of .0004 inches (0.010mm) and surface hardness of approximately 250 HV (anodized profiles should not be welded because of toxic fumes).

Torque Specifications

The tables below show the amount of torque in foot-lbs. and newton meters required to activate the 2 degree drop-lock feature for t-slotted profiles. Nut and bolt combination is preloaded when tightened to the minimum torque rating.

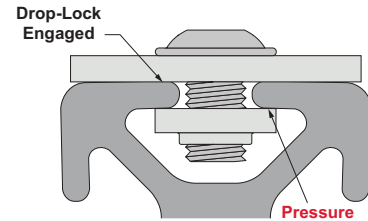

Fractional T-slotted Profiles

Part Number	Fastener Description	Tested Profile	Minimum Torque Ft-lbs.	Maximum Torque Ft-lbs.
3320	5/16-18 x 11/16 Flanged BHSCS & Economy T-Nut	1515	10.00	15.00
3325	5/16-18 x 3/4 Economy T-Slot Stud, Washer & Hex Nut	1515	25.00	30.00
3360	15 Series Anchor Fastener Assembly	1515-Lite	10.00	20.00
3380	15 Series End Fastener Assembly	1515-Lite	10.00	22.00
3321	1/4-20 x 1/2 Flanged BHSCS & Economy T-Nut	1010	4.00	6.00
3395	10 Series Anchor Fastener Assembly	1010	3.00	17.00
3381	10 Series End Fastener Assembly	1010	4.00	17.00

Metric T-slotted Profiles

Part Number	Fastener Description	Tested Profile	Minimum Torque Newton Meters	Maximum Torque Newton Meters
75-3422	M8 x 16mm BHSCS & Economy T-Nut	40-4040	13	20
75-3500	M8 x 20mm Economy T-Slot Stud, Washer & Hex Nut	40-4040	40	54
40-3897	40 Series Anchor Fastener Assembly	40-4040-Lite	13	37
40-3891	40 Series End Fastener Assembly	40-4040-Lite	13	29
75-3404	M6 x 10mm BHSCS & Economy T-Nut	25-2525	5	8
25-3896	25 Series Anchor Fastener Assembly	25-2525	4	23
25-3895	25 Series End Fastener Assembly	25-2525	5	23

The estimated torque calculations in this chart are offered as a guide only. Use of this content by anyone is the sole responsibility of that person and they assume all risk. Due to many variables that affect the torque-tension relationship like human error, surface texture, and lubrication the only way to determine the correct torque is through experimentation under actual joint and assembly conditions.

Fastener Application Test

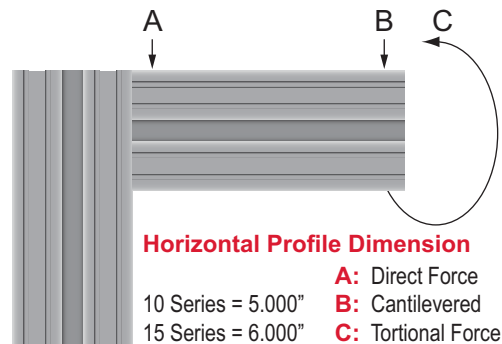
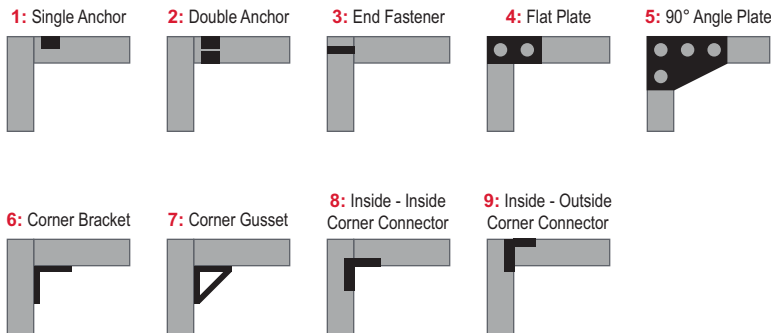

Fastener	1010 Profile			1515-Lite Profile			1515 Profile		
	A (lbs)	B (lbs)	C (Inch-lbs)	A (lbs)	B (lbs)	C (Inch-lbs)	A (lbs)	B (lbs)	C (Inch-lbs)
1	500	250	180	950	625	540	950	1,000	700
2	900	250	260	1,200	700	1,150	1,200	1,200	2,000
3	450	200	325	1,000	500	680	1,000	820	1,150
4	175	50	400	225	200	1,000	225	200	1,100
5	175	50	500	250	200	1,120	250	200	1,260
6	325	75	180	375	225	500	575	225	500
7	325	220	260	375	750	500	575	750	500
8	—	—	—	50	50	50	—	—	—
9	—	—	—	240	220	240	—	—	—

Introduction to Ready Tube[™]

Ready Tube is an alternative to steel tubular framing; it is lightweight yet strong and durable. Ready Tube is also corrosion resistant, easy to assemble and cost-effective. Ready Tube is appropriately named; it is ready to use without the need for additional machining.

With or Without Pre-Drilled Holes

Ready Tube is available with or without pre-drilled holes. Profiles with pre-drilled holes have 1.50" centerlines between holes, which enables quick and easy connections without the need for machining.

Ready Tube also comes without pre-drilled holes which make it perfect for customized connections and readily attaching to existing builds. In addition, dirt and water have difficulty getting into these profiles and they are easily cleaned, making it a good fit for applications in laboratories and the food industry.

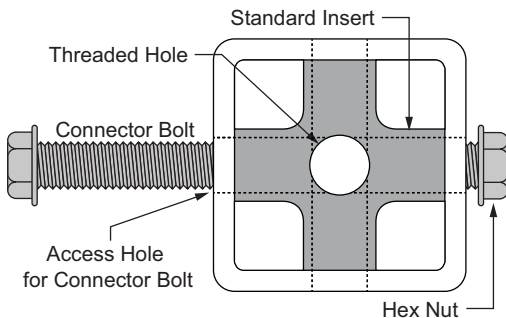
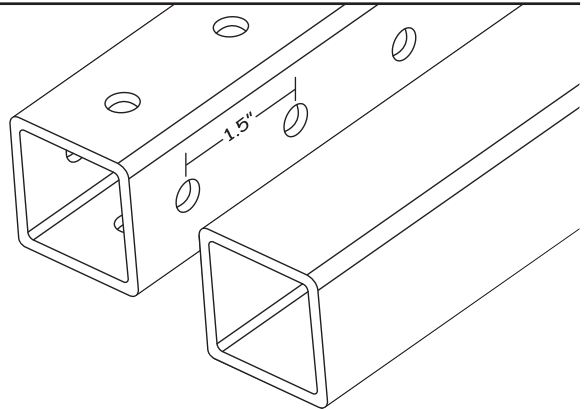

How Ready Tube Works

The most commonly used fastener for Ready Tube is the **Standard Tube Insert** which requires only a wrench to connect. It includes a connector bolt, hex nut and insert that goes inside the Ready Tube profile and is accessed by the pre-drilled holes. 80/20 does offer additional fasteners for Ready Tube; for more information flip to page 417.

Ready Tube Connects in 4 Steps



Advantages of Ready Tube

Ready Tube, similar to the standard 80/20 T-slotted profile, is made of an aluminum alloy which offers several advantages:

- Strong
- Lightweight
- High strength-to-weight ratio
- Resilient
- Corrosion-resistant

Keep in mind that Ready Tube profiles come standard with a clear anodize finish which prevents oxidation and corrosion while providing a matte finish.

The Shapes of Ready Tube

The properties of Ready Tube make it perfect for evolving and changing applications. It works well in builds such as workstations, tables, carts, flow racks, and material handling shelving and racks. When using Ready Tube in your build you have 3 main profile options; square, P-tube, and A-tube.



SQUARE



P-TUBE

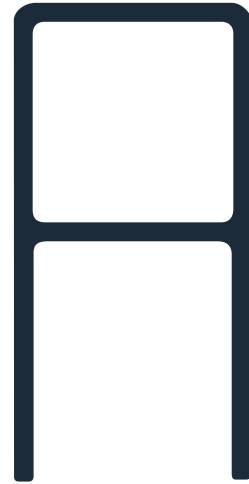

A-TUBE

Square Ready Tube profiles are easy to clean and aesthetically appealing, while P-tube profiles have flanges that work well for holding panels. A-tubes are available with or without notches and are perfect for applications such as gravity racks or material handling shelves.

Need to Know

Ready Tube is available with or without pre-manufactured holes and is a great solution for material handling applications.

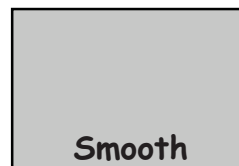

Smooth

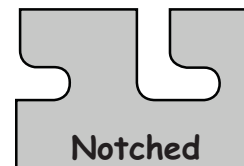

Notched

Introduction to Quick Frame[™]

Quick Frame is an alternative to steel tubular framing and wood construction. It is simple to use, lightweight and can help reduce your product cost. Quick Frame requires few parts for assembly and connects with just one tool. It is a boltless method that fastens with nylon tube inserts. This means that Quick Frame does exactly what its name implies; connects quickly to form light yet sturdy builds.

How Quick Frame Works

Quick Frame profiles are designed specifically to work with Quick Frame connectors; they have built-in ridges that bite into the connector to create tension without the use of hardware. The profiles connect quickly and easily using only a soft-faced mallet to form light-duty yet sturdy builds.

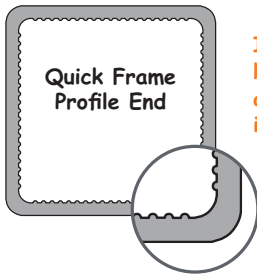

Internal grooves in the Quick Frame profile hold connector in place without the use of additional hardware. A soft-faced mallet is all that is required for assembly.

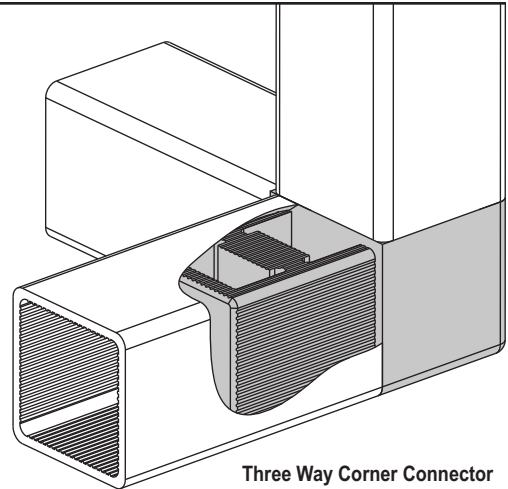

Quick Frame Connects in 4 Steps

-
-
-
-

Quick Frame: Strong, Light-Duty Solution

Quick Frame is made of aluminum but is even lighter than most other framing materials such as wood and PVC. This means that Quick Frame retains structural rigidity making it perfect for light-duty applications such as shelving and storage solutions, barrier and splash guards, enclosures, and retail displays.

Added Benefits of Quick Frame

Quick Frame is easily incorporated into preexisting projects and frames already built with T-slotted aluminum profiles. Keep in mind, too, that Quick Frame is anodized which means that it is corrosion resistant and aesthetically appealing. The nylon connectors do not degrade and can even be submerged in water without rusting.

The Shapes of Quick Frame

There are 3 main shapes when it comes to Quick Frame; square, flanged, and twin flanged. Square profiles hinder dirt and debris buildup and are easy to clean while single flanged profiles are perfect for building doors or adding panels. Twin flanged profiles hold panels in place for vertical applications such as enclosures.

Within both the flanged and twin flanged shapes you can choose from either a single flange, a right angle flange or a double flange, allowing you to find the specific Quick Frame profile perfect for your build.

SQUARE



Need to Know

Quick Frame is a light-duty alternative to its heavier steel counterpart, with options for flanged ends to hold guarding.



FLANGED

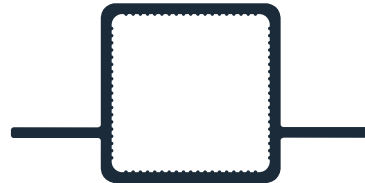
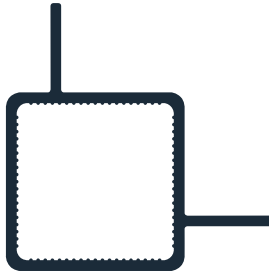
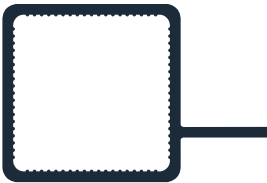

TWIN FLANGED

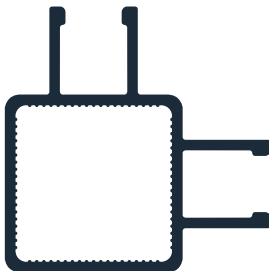
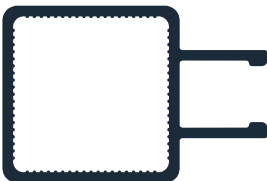

T-Slotted Profile Quick Reference

CONTINUE 

10 Series



Part No.	1010-S	1010	1001-S	1001	1002-S	1002
Stock Length	145" or 242"	97", 145", 242"	145" or 242"	145" or 242"	145" or 242"	145" or 242"
Material / Alloy*	Aluminum / 6105-T5*					
Finish	Anodize					
2° Drop Lock	Yes					
Moment of Inertia	IX = 0.0463 ^{™4} IY = 0.0463 ^{™4}	IX = 0.0442 ^{™4} IY = 0.0442 ^{™4}	IX = 0.0562 ^{™4} IY = 0.0517 ^{™4}	IX = 0.0493 ^{™4} IY = 0.0542 ^{™4}	IX = 0.0518 ^{™4} IY = 0.0518 ^{™4}	IX = 0.0492 ^{™4} IY = 0.0492 ^{™4}
Estimated Area	0.437 in. ²	0.435 in. ²	0.508 in. ²	0.506 in. ²	0.484 in. ²	0.483 in. ²
Weight Per Inch	0.0424 lb	0.0424 lb	0.0493 lb	0.0493 lb	0.0470 lb	0.0470 lb

* Or comparable

10 Series



Part No.	1003-S	1003	1004-S	1004	1012-S	1012
Stock Length	145" or 242"	145" or 242"	145" or 242"	145" or 242"	145" or 242"	145" or 242"
Material / Alloy*	Aluminum / 6105-T5*					
Finish	Anodize					
2° Drop Lock	Yes					
Moment of Inertia	IX = 0.0510 ^{™4} IY = 0.0463 ^{™4}	IX = 0.0441 ^{™4} IY = 0.0491 ^{™4}	IX = 0.0563 ^{™4} IY = 0.0467 ^{™4}	IX = 0.0443 ^{™4} IY = 0.0541 ^{™4}	IX = 0.0414 ^{™4} IY = 0.0414 ^{™4}	IX = 0.0400 ^{™4} IY = 0.0400 ^{™4}
Estimated Area	0.461 in. ²	0.459 in. ²	0.484 in. ²	0.482 in. ²	0.423 in. ²	0.423 in. ²
Weight Per Inch	0.0447 lb	0.0448 lb	0.0470 lb	0.0470 lb	0.0411 lb	0.0413 lb

* Or comparable

10 Series



Part No.	1050	2012	1020-S	1020	1030-S	1030
Stock Length	145"	145"	145" or 242"	97", 145", 242"	145" or 242"	145" or 242"
Material / Alloy*	Aluminum / 6105-T5*					
Finish	Anodize					
2° Drop Lock	Yes					
Moment of Inertia	IX = 0.0074 ^{™4} IY = 0.0323 ^{™4}	IX = 0.2253 ^{™4} IY = 0.0146 ^{™4}	IX = 0.0863 ^{™4} IY = 0.3084 ^{™4}	IX = 0.3078 ^{™4} IY = 0.0833 ^{™4}	IX = 0.1262 ^{™4} IY = 0.9599 ^{™4}	IX = 0.9711 ^{™4} IY = 0.1238 ^{™4}
Estimated Area	0.320 in. ²	0.564 in. ²	0.786 in. ²	0.787 in. ²	1.135 in. ²	1.140 in. ²
Weight Per Inch	0.0312 lb	0.0550 lb	0.0763 lb	0.0768 lb	0.1101 lb	0.1112 lb

* Or comparable

T-Slotted Profile Quick Reference

CONTINUE

10 Series



Part No.	2020-S	2020	2040-S	2040
Stock Length	145" or 242"	145" or 242"	145" or 242"	145" or 242"
Material / Alloy*	Aluminum / 6105-T5*			
Finish	Anodize			
2° Drop Lock	Yes			
Moment of Inertia	IX = 0.5545 ^{m4} IY = 0.5545 ^{m4}	IX = 0.5509 ^{m4} IY = 0.5509 ^{m4}	IX = 1.0543 ^{m4} IY = 3.5123 ^{m4}	IX = 3.5168 ^{m4} IY = 1.0513 ^{m4}
Estimated Area	1.216 in. ²	1.228 in. ²	2.255 in. ²	2.290 in. ²
Weight Per Inch	0.1179 lb	0.1198 lb	0.2188 lb	0.2233 lb

* Or comparable

15 Series



Part No.	1515-ULS	1515-UL	1515-LS	1515-Lite	1515-S	1515
Stock Length	145" or 242"	145" or 242"	145" or 242"	97", 145", 242"	145" or 242"	97", 145", 242"
Material / Alloy*	Aluminum / 6105-T5*					
Finish	Anodize					
2° Drop Lock	Yes					
Moment of Inertia	IX = 0.1765 ^{m4} IY = 0.1765 ^{m4}	IX = 0.1772 ^{m4} IY = 0.1772 ^{m4}	IX = 0.1921 ^{m4} IY = 0.1921 ^{m4}	IX = 0.1853 ^{m4} IY = 0.1853 ^{m4}	IX = 0.2631 ^{m4} IY = 0.2631 ^{m4}	IX = 0.2542 ^{m4} IY = 0.2542 ^{m4}
Estimated Area	0.810 in. ²	0.787 in. ²	0.882 in. ²	0.896 in. ²	1.138 in. ²	1.152 in. ²
Weight Per Inch	0.0790 lb	0.0768 lb	0.0860 lb	0.0873 lb	0.1109 lb	0.1123 lb

* Or comparable

15 Series



Part No.	1501-LS	1501	1502-LS	1502	1503-LS	1503
Stock Length	145" or 242"	145" or 242"	145" or 242"	145" or 242"	145" or 242"	145" or 242"
Material / Alloy*	Aluminum / 6105-T5*					
Finish	Anodize					
2° Drop Lock	Yes					
Moment of Inertia	IX = 0.1820 ^{m4} IY = 0.1799 ^{m4}	IX = 0.1726 ^{m4} IY = 0.1694 ^{m4}	IX = 0.1834 ^{m4} IY = 0.1834 ^{m4}	IX = 0.1660 ^{m4} IY = 0.1730 ^{m4}	IX = 0.1859 ^{m4} IY = 0.1840 ^{m4}	IX = 0.1760 ^{m4} IY = 0.1790 ^{m4}
Estimated Area	0.815 in. ²	0.826 in. ²	0.832 in. ²	0.844 in. ²	0.848 in. ²	0.862 in. ²
Weight Per Inch	0.0788 lb	0.0805 lb	0.0811 lb	0.0823 lb	0.0827 lb	0.0840 lb

* Or comparable

T-Slotted Profile Quick Reference

CONTINUE 

15 15 Series



Part No.	1504-LS	1504	1547	1517-LS	1517	1575
Stock Length	145" or 242"	145" or 242"	145" or 242"	145" or 242"	97", 145", 242"	145" or 242"
Material / Alloy*	Aluminum / 6105-T5*					
Finish	Anodize					
2° Drop Lock	Yes					
Moment of Inertia	IX = 0.1796 ^{m4} IY = 0.1759 ^{m4}	IX = 0.1729 ^{m4} IY = 0.1665 ^{m4}	IX = 0.1365 ^{m4} IY = 0.1365 ^{m4}	IX = 0.1686 ^{m4} IY = 0.1686 ^{m4}	IX = 0.1662 ^{m4} IY = 0.1662 ^{m4}	IX = 0.0380 ^{m4} IY = 0.1470 ^{m4}
Estimated Area	0.815 in. ²	0.827 in. ²	0.740 in. ²	0.748 in. ²	0.765 in. ²	0.686 in. ²
Weight Per Inch	0.0795 lb	0.0807 lb	0.0723 lb	0.0729 lb	0.0746 lb	0.0669 lb

* Or comparable

15 15 Series



Part No.	1534-Lite	3075	3034-Lite	1530-ULS	1530-UL	1530-LS
Stock Length	145"	145" or 242"	145"	145" or 242"	145" or 242"	145" or 242"
Material / Alloy*	Aluminum / 6105-T5*					
Finish	Anodize					
2° Drop Lock	Yes					
Moment of Inertia	IX = 0.0356 ^{m4} IY = 0.1360 ^{m4}	IX = 1.0672 ^{m4} IY = 0.0789 ^{m4}	IX = 0.9829 ^{m4} IY = 0.0725 ^{m4}	IX = 1.2855 ^{m4} IY = 0.3317 ^{m4}	IX = 1.2481 ^{m4} IY = 0.3177 ^{m4}	IX = 1.3881 ^{m4} IY = 0.4061 ^{m4}
Estimated Area	0.634 in. ²	1.320 in. ²	1.186 in. ²	1.388 in. ²	1.354 in. ²	1.682 in. ²
Weight Per Inch	0.0618 lb	0.1287 lb	0.1157 lb	0.1350 lb	0.1320 lb	0.1640 lb

* Or comparable

15 15 Series



Part No.	1530-Lite	1530-S	1530	1545-S	1545	3030-LS
Stock Length	97", 145", 242"	145" or 242"	97", 145", 242"	145" or 242"	145" or 242"	145" or 242"
Material / Alloy*	Aluminum / 6105-T5*					
Finish	Anodize					
2° Drop Lock	Yes					
Moment of Inertia	IX = 1.3847 ^{m4} IY = 0.3935 ^{m4}	IX = 1.8127 ^{m4} IY = 0.4957 ^{m4}	IX = 1.8042 ^{m4} IY = 0.4824 ^{m4}	IX = 5.6675 ^{m4} IY = 0.7282 ^{m4}	IX = 5.6929 ^{m4} IY = 0.7097 ^{m4}	IX = 2.6861 ^{m4} IY = 2.6861 ^{m4}
Estimated Area	1.722 in. ²	2.036 in. ²	2.077 in. ²	2.935 in. ²	3.002 in. ²	2.659 in. ²
Weight Per Inch	0.1679 lb	0.1985 lb	0.2025 lb	0.2862 lb	0.2927 lb	0.2593 lb

* Or comparable

T-Slotted Profile Quick Reference

CONTINUE 

15 Series



Part No.	3030-Lite	3030-S	3030	3060
Stock Length	145" or 242"	145" or 242"	145" or 242"	145", 192", 242"
Material / Alloy*	Aluminum / 6105-T5*			
Finish	Anodize			
2° Drop Lock	Yes			
Moment of Inertia	IX = 2.6959 ⁱⁿ⁴ IY = 2.6959 ⁱⁿ⁴	IX = 3.3496 ⁱⁿ⁴ IY = 3.3496 ⁱⁿ⁴	IX = 3.4133 ⁱⁿ⁴ IY = 3.4133 ⁱⁿ⁴	IX = 22.0300 ⁱⁿ⁴ IY = 6.5164 ⁱⁿ⁴
Estimated Area	2.763 in. ²	3.109 in. ²	3.212 in. ²	5.963 in. ²
Weight Per Inch	0.2695 lb	0.3032 lb	0.3132 lb	0.5815 lb

* Or comparable

20 Series



Part No.	20-2020	20-2040	20-4040
Stock Length	4 or 6 Meter	4 or 6 Meter	4 or 6 Meter
Material / Alloy*	Aluminum / 6105-T5*		
Finish	Anodize		
2° Drop Lock	Yes		
Moment of Inertia	IX = 0.6826 cm ⁴ IY = 0.6826 cm ⁴	IX = 4.5357 cm ⁴ IY = 1.2133 cm ⁴	IX = 7.8219 cm ⁴ IY = 7.8219 cm ⁴
Estimated Area	1.591 cm ²	2.750 cm ²	4.227 cm ²
Weight Per Meter	0.4420 kg	0.7427 kg	1.1722 kg

* Or comparable

25 Series



Part No.	25-2525	25-2501	25-2502	25-2503	25-2504	25-2527
Stock Length	4 or 6 Meter	4 or 6 Meter	4 or 6 Meter	4 or 6 Meter	4 or 6 Meter	4 or 6 Meter
Material / Alloy*	Aluminum / 6105-T5*					
Finish	Anodize					
2° Drop Lock	Yes					
Moment of Inertia	IX = 1.7726 cm ⁴ IY = 1.7726 cm ⁴	IX = 2.1892 cm ⁴ IY = 1.9873 cm ⁴	IX = 1.9780 cm ⁴ IY = 1.9780 cm ⁴	IX = 1.9688 cm ⁴ IY = 1.7669 cm ⁴	IX = 2.2730 cm ⁴ IY = 1.7761 cm ⁴	IX = 1.4578 cm ⁴ IY = 1.4578 cm ⁴
Estimated Area	2.746 cm ²	3.185 cm ²	3.039 cm ²	2.892 cm ²	3.039 cm ²	2.428 cm ²
Weight Per Meter	0.7427 kg	0.8608 kg	0.8214 kg	0.7820 kg	0.8214 kg	0.6568 kg

* Or comparable

T-Slotted Profile Quick Reference

CONTINUE 

PROFILES

25 Series

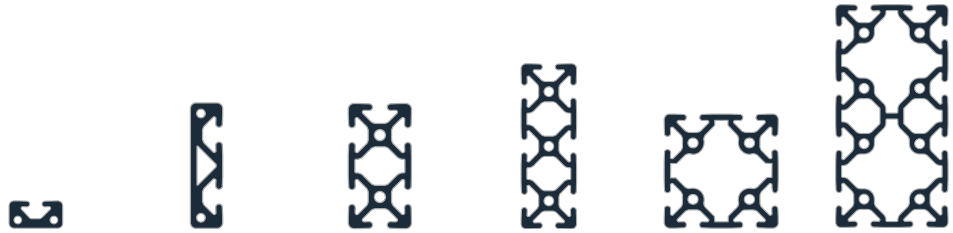

Part No.	25-2514	25-5013	25-2550	25-2576	25-5050	25-5010
Stock Length	4 Meter	4 Meter	4 or 6 Meter	4 or 6 Meter	4 or 6 Meter	4 or 6 Meter
Material / Alloy*	Aluminum / 6105-T5*					
Finish	Anodize					
2° Drop Lock	Yes					
Moment of Inertia	IX = 0.3030 cm ⁴ IY = 1.3003 cm ⁴	IX = 8.8452 cm ⁴ IY = 0.5897 cm ⁴	IX = 12.1714 cm ⁴ IY = 3.1966 cm ⁴	IX = 37.2852 cm ⁴ IY = 4.5921 cm ⁴	IX = 21.1231 cm ⁴ IY = 21.1231 cm ⁴	IX = 132.0109 cm ⁴ IY = 39.1136 cm ⁴
Estimated Area	2.022 cm ²	3.528 cm ²	4.857 cm ²	6.889 cm ²	7.487 cm ²	13.743 cm ²
Weight Per Meter	0.5458 kg	0.9628 kg	1.3135 kg	1.8665 kg	2.0240 kg	3.7133 kg

* Or comparable

30 Series



Part No.	30-3030	30-3001	30-3002	30-3003	30-3004	30-3022
Stock Length	4 or 6 Meter	4 or 6 Meter	4 or 6 Meter	4 or 6 Meter	4 or 6 Meter	4 or 6 Meter
Material / Alloy*	Aluminum / 6105-T5*					
Finish	Anodize					
2° Drop Lock	Yes					
Moment of Inertia	IX = 2.7221 cm ⁴ IY = 2.7221 cm ⁴	IX = 2.7176 cm ⁴ IY = 2.6691 cm ⁴	IX = 2.6758 cm ⁴ IY = 2.6758 cm ⁴	IX = 2.6832 cm ⁴ IY = 2.6343 cm ⁴	IX = 2.6212 cm ⁴ IY = 2.5234 cm ⁴	IX = 2.2948 cm ⁴ IY = 2.2948 cm ⁴
Estimated Area	3.144 cm ²	3.067 cm ²	3.066 cm ²	3.065 cm ²	2.986 cm ²	2.840 cm ²
Weight Per Meter	0.8715 kg	0.8220 kg	0.8217 kg	0.8214 kg	0.8002 kg	0.7612 kg

* Or comparable

30 Series



Part No.	30-3060	30-6060
Stock Length	4 or 6 Meter	4 or 6 Meter
Material / Alloy*	Aluminum / 6105-T5*	
Finish	Anodize	
2° Drop Lock	Yes	
Moment of Inertia	IX = 5.4332 cm ⁴ IY = 19.6933 cm ⁴	IX = 36.3307 cm ⁴ IY = 36.3307 cm ⁴
Estimated Area	5.928 cm ²	9.299 cm ²
Weight Per Meter	1.6428 kg	2.5787 kg

* Or comparable

T-Slotted Profile Quick Reference

CONTINUE 

40 Series



Part No.	40-4040-UL	40-4040-Lite	40-4040	40-4001	40-4002	40-4003
Stock Length	4 or 6 Meter	4 or 6 Meter	4 or 6 Meter	4 or 6 Meter	4 or 6 Meter	4 or 6 Meter
Material / Alloy*	Aluminum / 6105-T5*					
Finish	Anodize					
2° Drop Lock	Yes					
Moment of Inertia	IX = 8.7059 cm ⁴ IY = 8.7059 cm ⁴	IX = 9.3983 cm ⁴ IY = 9.3983 cm ⁴	IX = 13.7870 cm ⁴ IY = 13.7870 cm ⁴	IX = 8.5389 cm ⁴ IY = 8.2599 cm ⁴	IX = 8.6303 cm ⁴ IY = 8.6303 cm ⁴	IX = 9.0094 cm ⁴ IY = 8.7823 cm ⁴
Estimated Area	5.750 cm ²	6.608 cm ²	8.742 cm ²	5.968 cm ²	6.118 cm ²	6.268 cm ²
Weight Per Meter	1.5533 kg	1.7860 kg	2.3640 kg	1.6142 kg	1.6535 kg	1.6947 kg

* Or comparable

40 Series



Part No.	40-4004	40-4030-Lite	40-4045-Lite	40-4093	40-4094	40-4096
Stock Length	4 or 6 Meter	4 or 6 Meter	4 or 6 Meter	4 Meter	4 Meter	4 Meter
Material / Alloy*	Aluminum / 6105-T5*					
Finish	Anodize					
2° Drop Lock	Yes					
Moment of Inertia	IX = 8.6050 cm ⁴ IY = 8.0430 cm ⁴	IX = 7.5590 cm ⁴ IY = 7.5590 cm ⁴	IX = 6.9991 cm ⁴ IY = 7.0047 cm ⁴	—	—	—
Estimated Area	5.954 cm ²	5.729 cm ²	5.541 cm ²	4.711 cm ²	6.309 cm ²	7.828 cm ²
Weight Per Meter	1.6106 kg	1.5497 kg	1.4996 kg	1.2742 kg	1.7054 kg	2.1170 kg

* Or comparable

40 Series



Part No.	40-4020	40-8020	40-4080-UL	40-4080-Lite	40-4080	40-4082-Lite
Stock Length	4 Meter	4 Meter	4 or 6 Meter	4 or 6 Meter	4 or 6 Meter	4 or 6 Meter
Material / Alloy*	Aluminum / 6105-T5*					
Finish	Anodize					
2° Drop Lock	Yes					
Moment of Inertia	IX = 1.8260 cm ⁴ IY = 6.6587 cm ⁴	IX = 49.6609 cm ⁴ IY = 3.7286 cm ⁴	IX = 63.1358 cm ⁴ IY = 15.4754 cm ⁴	IX = 71.8926 cm ⁴ IY = 18.7791 cm ⁴	IX = 97.6617 cm ⁴ IY = 25.2917 cm ⁴	IX = 66.4788 cm ⁴ IY = 16.3044 cm ⁴
Estimated Area	4.550 cm ²	8.482 cm ²	9.792 cm ²	12.532 cm ²	15.332 cm ²	10.982 cm ²
Weight Per Meter	1.2312 kg	2.2960 kg	2.6485 kg	3.3876 kg	4.1464 kg	2.9689 kg

* Or comparable

T-Slotted Profile Quick Reference

CONTINUE 

PROFILES

40 Series



Part No.	40-4083-Lite	40-4084-Lite	40-4085-Lite	40-4012	40-8080	40-8016
Stock Length	4 or 6 Meter	4 or 6 Meter	4 or 6 Meter	4 or 6 Meter	4 or 6 Meter	4 or 6 Meter
Material / Alloy*	Aluminum / 6105-T5*					
Finish	Anodize					
2° Drop Lock	Yes					
Moment of Inertia	IX = 68.1908 cm ⁴ IY = 16.4684 cm ⁴	IX = 69.7265 cm ⁴ IY = 16.6107 cm ⁴	IX = 67.8369 cm ⁴ IY = 15.9404 cm ⁴	IX = 306.3198 cm ⁴ IY = 36.8008 cm ⁴	IX = 171.6341 cm ⁴ IY = 171.6341 cm ⁴	IX = 1111.9793 cm ⁴ IY = 322.7985 cm ⁴
Estimated Area	11.074 cm ²	11.174 cm ²	11.000 cm ²	21.927 cm ²	23.573 cm ²	43.490 cm ²
Weight Per Meter	2.9957 kg	3.0208 kg	2.9760 kg	5.9306 kg	6.3762 kg	11.7627 kg

* Or comparable

45 Series



Part No.	45-4545-Lite	45-4545	45-4590	45-9090
Stock Length	4 or 6 Meter	4 or 6 Meter	4 or 6 Meter	4 or 6 Meter
Material / Alloy*	Aluminum / 6105-T5*			
Finish	Anodize			
2° Drop Lock	No			
Moment of Inertia	IX = 9.2029 cm ⁴ IY = 9.2029 cm ⁴	IX = 13.9604 cm ⁴ IY = 13.9604 cm ⁴	IX = 104.2072 cm ⁴ IY = 25.2637 cm ⁴	IX = 178.4968 cm ⁴ IY = 179.4968 cm ⁴
Estimated Area	5.167 cm ²	7.587 cm ²	12.615 cm ²	20.014 cm ²
Weight Per Meter	1.3976 kg	2.0455 kg	3.4109 kg	5.4116 kg

* Or comparable

Ready Tube™ Profile Quick Reference

RT Ready Tube

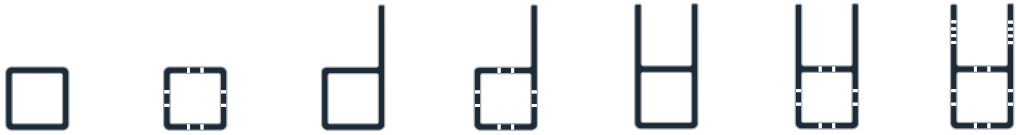

Part No.	9700	9701	9705	9706	9725	9726	9728
Stock Length	100" or 150"	100" or 150"	100" or 150"	100" or 150"	100" or 150"	100" or 150"	100" or 150"
Material / Alloy*	Aluminum / 6105-T5*						
Finish	Anodize						
Estimated Area	0.6775 in. ²	0.6775 in. ²	0.8691 in. ²	0.8691 in. ²	1.0610 in. ²	1.0610 in. ²	1.0610 in. ²
Weight Per Inch	0.0660 lb	0.0660 lb	0.1033 lb	0.0848 lb	0.1033 lb	0.1033 lb	0.1033 lb
Pre-drilled Holes	No	Yes	No	Yes	No	Yes	Yes
Notched Flanges	No	No	No	No	No	No	Yes

* Or comparable

Quick Frame™ Profile Quick Reference

QF Quick Frame



Part No.	9000	9005	9010	9015	9025	9030	9035
Stock Length	145"	145"	145"	145"	145"	145"	145"
Material / Alloy*	Aluminum / 6105-T5*						
Finish	Anodize						
Estimated Area	0.2228 in. ²	0.2528 in. ²	0.2828 in. ²	0.2828 in. ²	0.2889 in. ²	0.3550 in. ²	0.3550 in. ²
Weight Per Inch	0.0231 lb	0.0261 lb	0.0291 lb	0.0291 lb	0.0296 lb	0.0362 lb	0.0362 lb

* Or comparable

1.00" X 1.00" Smooth Surface T-Slotted Profile - Four Open T-Slots

1010-S Profile

1010-S is a 1.00" x 1.00" fractional 10 series square T-slot profile with four open T-slots, one on each 1.00" face. The profile is smooth, which makes it resistant to dirt and debris buildup while also being easy to clean. The 1010-S profile is compatible with all 10 series fasteners. The four open T-slots enable access from any direction and are useful for mounting accessories.

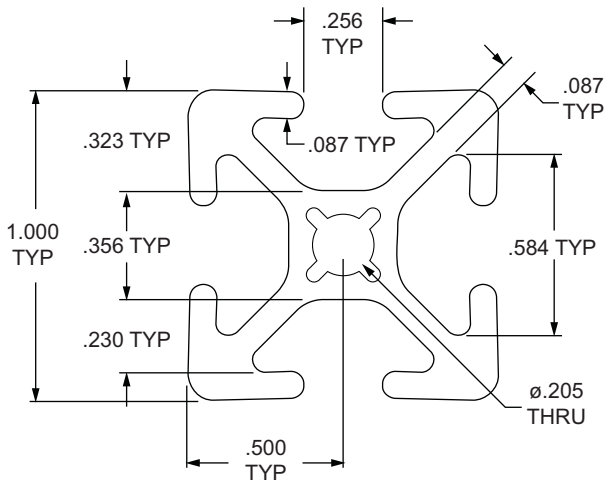

Part No.	Series	Stock Length	Material	Alloy**	Finish	Drop Lock	Moment of Inertia	Surface Area	Yield Strength	Modulus of Elasticity	Weight
1010-S *	10	145", 242"	Aluminum	6105-T5	Clear Anodize	2°	IX = 0.0463 ³⁴ IY = 0.0463 ³⁴	0.437 in. ²	35,000 psi	10,200,000 lb / in. ²	0.0424 lb / in.
1010-S-Black-FB		per inch			Black Anodize						

* The above profiles are sold per inch or stock length.

** Or comparable

Standard Machining Services

Service No.	Series	Service Description	Reference Page
7005	10	Cut to Length	851
7051	10	Access Hole	855
7042	10	Anchor Counterbore	857
7061	10	Tap Profile End	853

1010 Profile

1010 is a 1.00" x 1.00" fractional 10 series square T-slot profile with four open T-slots, one on each 1.00" face. The profile has align-a-grooves to assist in aligning connecting profiles. The 1010 profile is compatible with all 10 series fasteners. This profile lends itself to machine guards, sound enclosures, work benches, panel mount racks and displays. The four open T-slots enable access from any direction and are useful for mounting accessories.

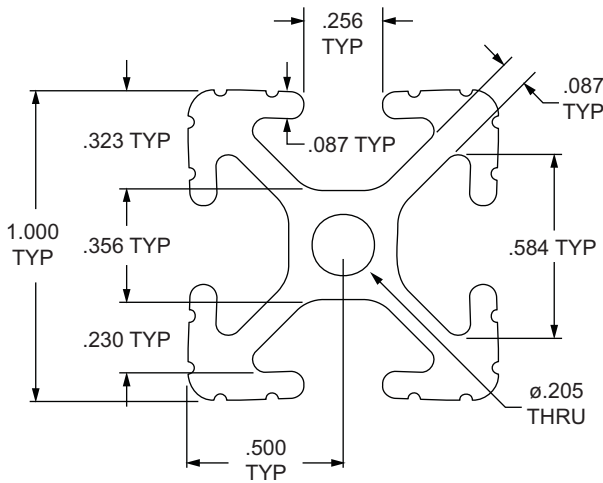

Part No.	Series	Stock Length	Material	Alloy**	Finish	Drop Lock	Moment of Inertia	Surface Area	Yield Strength	Modulus of Elasticity	Weight
1010 *	10	97", 145", 242"	Aluminum	6105-T5	Clear Anodize	2"	IX = 0.0442 ^{m4} IY = 0.0442 ^{m4}	0.435 in. ²	35,000 psi	10,200,000 lb / in. ²	0.0424 lb / in.
1010-Black *		145"			Black Anodize						
1010-Black-FB		per inch			Black Anodize						
1010-Yellow *		145"			Yellow Powder Coat						

* The above profiles are sold per inch or stock length.

** Or comparable

Standard Machining Services

Service No.	Series	Service Description	Reference Page
7005	10	Cut to Length	851
7051	10	Access Hole	855
7042	10	Anchor Counterbore	857
7061	10	Tap Profile End	853

1.00" X 1.00" Smooth Surface T-Slotted Profile - Single Open T-Slot

1001-S Profile

1001-S is a 1.00" x 1.00" fractional 10 series square T-slot profile with one open T-slot on one 1.00" face. The profile is smooth, which makes it resistant to dirt and debris buildup while also being easy to clean. The 1001-S profile is compatible with 10 series fasteners. The three closed faces on this profile provide a clean, aesthetic look and it lends itself to furniture, displays, desks, trade show booths, or retail kiosks.

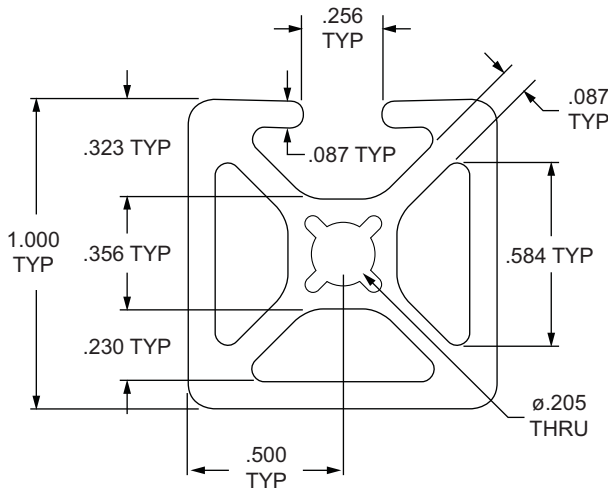

Part No.	Series	Stock Length	Material	Alloy**	Finish	Drop Lock	Moment of Inertia	Surface Area	Yield Strength	Modulus of Elasticity	Weight
1001-S *	10	145", 242"	Aluminum	6105-T5	Clear Anodize	2°	IX = 0.0562" ⁴ IY = 0.0517" ⁴	0.437 in. ²	35,000 psi	10,200,000 lb / in. ²	0.0493 lb / in.
1001-S-Black-FB		per inch			Black Anodize						

* The above profiles are sold per inch or stock length.

** Or comparable

Standard Machining Services

Service No.	Series	Service Description	Reference Page
7005	10	Cut to Length	851
7051	10	Access Hole	855
7042	10	Anchor Counterbore	857
7061	10	Tap Profile End	853

1001 Profile

1001 is a 1.00" x 1.00" fractional 10 series square T-slot profile with one open T-slot on one 1.00" face. The profile has align-a-grooves to assist in alignment when connecting profiles. The 1001 profile is compatible with 10 series fasteners. The three closed faces on this profile provide a clean, aesthetic look and it lends itself to furniture, displays, desks, trade show booths, or retail kiosks.

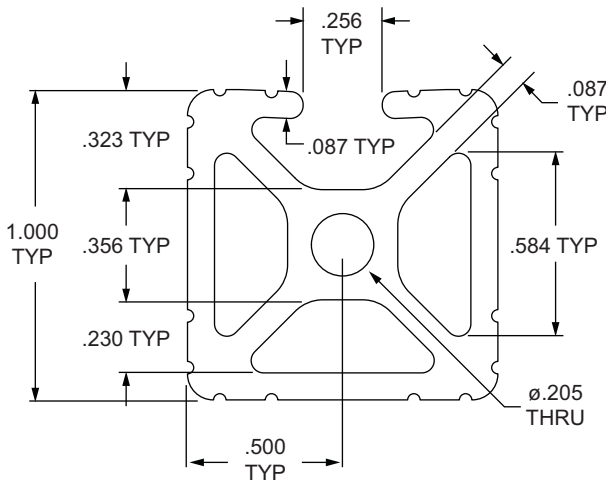

Part No.	Series	Stock Length	Material	Alloy**	Finish	Drop Lock	Moment of Inertia	Surface Area	Yield Strength	Modulus of Elasticity	Weight
1001 *	10	145", 242"	Aluminum	6105-T5	Clear Anodize	2°	IX = 0.0493 ⁱⁿ⁴ IY = 0.0542 ⁱⁿ⁴	0.506 in. ²	35,000 psi	10,200,000 lb / in. ²	0.0493 lb / in.
1001-Black-FB		per inch			Black Anodize						

* The above profiles are sold per inch or stock length.

** Or comparable

Standard Machining Services

Service No.	Series	Service Description	Reference Page
7005	10	Cut to Length	851
7051	10	Access Hole	855
7042	10	Anchor Counterbore	857
7061	10	Tap Profile End	853

1.00" X 1.00" Smooth Surface T-Slotted Profile - Two Adjacent Open T-Slots

1002-S Profile

1002-S is a 1.00" x 1.00" fractional 10 series square T-slot profile with two adjacent open T-slots, one on two 1.00" faces. The profile is smooth, which makes it resistant to dirt and debris buildup while also being easy to clean. The 1002-S profile is compatible with 10 series fasteners. The two closed faces on this profile provide a clean, aesthetic look and lends itself to furniture, displays, desks, trade show booths, or retail kiosks.

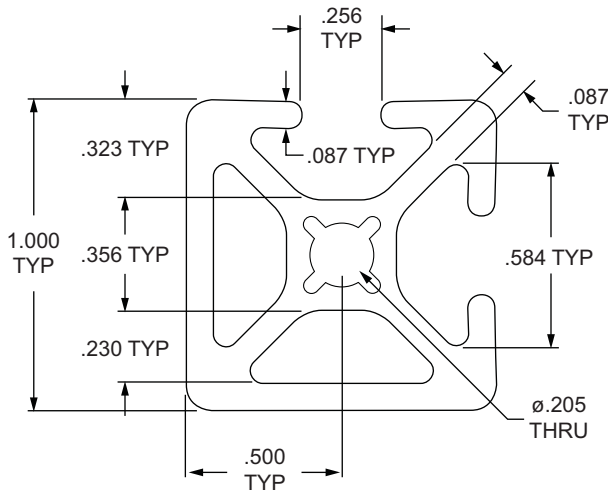

Part No.	Series	Stock Length	Material	Alloy**	Finish	Drop Lock	Moment of Inertia	Surface Area	Yield Strength	Modulus of Elasticity	Weight
1002-S *	10	145", 242"	Aluminum	6105-T5	Clear Anodize	2°	IX = 0.0518" ⁴ IY = 0.0518" ⁴	0.484 in. ²	35,000 psi	10,200,000 lb / in. ²	0.0470 lb / in.
1002-S-Black-FB		per inch			Black Anodize						

* The above profiles are sold per inch or stock length.

** Or comparable

Standard Machining Services

Service No.	Series	Service Description	Reference Page
7005	10	Cut to Length	851
7051	10	Access Hole	855
7042	10	Anchor Counterbore	857
7061	10	Tap Profile End	853

1002 Profile

1002 is a 1.00" x 1.00" fractional 10 series square T-slot profile with two adjacent open T-slots, one on two 1.00" faces. The profile has align-a-grooves to assist in alignment when connecting profiles. The 1002 profile is compatible with 10 series fasteners. The two closed faces on this profile provide a clean, aesthetic look and lends itself to furniture, displays, desks, trade show booths, or retail kiosks.

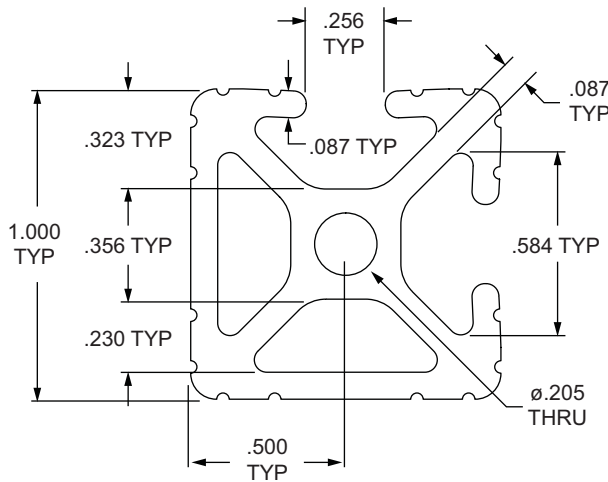

Part No.	Series	Stock Length	Material	Alloy**	Finish	Drop Lock	Moment of Inertia	Surface Area	Yield Strength	Modulus of Elasticity	Weight
1002 *	10	145", 242"	Aluminum	6105-T5	Clear Anodize	2°	IX = 0.0492 ⁱⁿ⁴ IY = 0.0492 ⁱⁿ⁴	0.483 in. ²	35,000 psi	10,200,000 lb / in. ²	0.0470 lb / in.
1002-Black-FB		per inch			Black Anodize						

* The above profiles are sold per inch or stock length.

** Or comparable

Standard Machining Services

Service No.	Series	Service Description	Reference Page
7005	10	Cut to Length	851
7051	10	Access Hole	855
7042	10	Anchor Counterbore	857
7061	10	Tap Profile End	853

1.00" X 1.00" Smooth Surface T-Slotted Profile - Three Adjacent Open T-Slots

1003-S Profile

1003-S is a 1.00" x 1.00" fractional 10 series square T-slot profile with three adjacent open T-slots, one on three 1.00" faces. The profile is smooth, which makes it resistant to dirt and debris buildup while also being easy to clean. The 1003-S profile is compatible with 10 series fasteners. The closed face on this profile provides a clean, aesthetic look and lends itself to work spaces, displays, or retail kiosks.

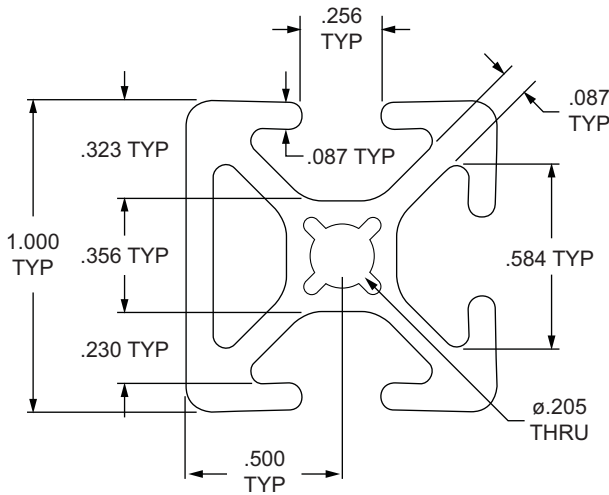

Part No.	Series	Stock Length	Material	Alloy**	Finish	Drop Lock	Moment of Inertia	Surface Area	Yield Strength	Modulus of Elasticity	Weight
1003-S *	10	145", 242"	Aluminum	6105-T5	Clear Anodize	2°	IX = 0.0510 ⁱⁿ ⁴ IY = 0.0463 ⁱⁿ ⁴	0.461 in. ²	35,000 psi	10,200,000 lb / in. ²	0.0447 lb / in.
1003-S-Black-FB		per inch			Black Anodize						

* The above profiles are sold per inch or stock length.

** Or comparable

Standard Machining Services

Service No.	Series	Service Description	Reference Page
7005	10	Cut to Length	851
7051	10	Access Hole	855
7042	10	Anchor Counterbore	857
7061	10	Tap Profile End	853

1003 Profile

1003 is a 1.00" x 1.00" fractional 10 series square T-slot profile with three adjacent open T-slots, one on three 1.00" faces. The profile has align-a-grooves to assist in alignment when connecting profiles. The 1003 profile is compatible with 10 series fasteners. The closed face on this profile provides a clean, aesthetic look and lends itself to work spaces, displays, or retail kiosks.

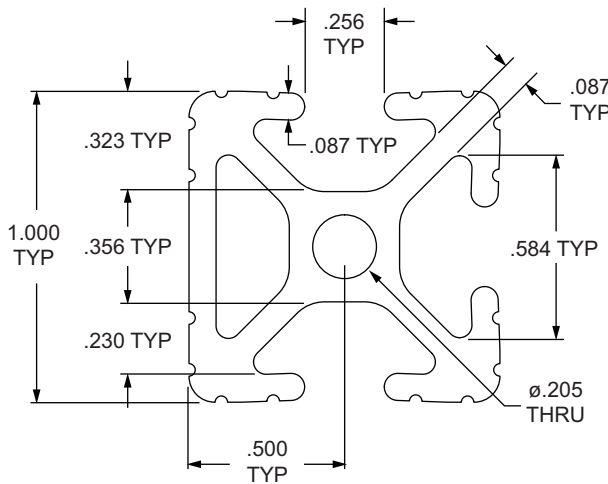

Part No.	Series	Stock Length	Material	Alloy**	Finish	Drop Lock	Moment of Inertia	Surface Area	Yield Strength	Modulus of Elasticity	Weight
1003 *	10	145", 242"	Aluminum	6105-T5	Clear Anodize	2°	IX = 0.0441 ^{in.4} IY = 0.0491 ^{in.4}	0.459 in. ²	35,000 psi	10,200,000 lb / in. ²	0.0448 lb / in.
1003-Black-FB		per inch			Black Anodize						

* The above profiles are sold per inch or stock length.

** Or comparable

Standard Machining Services

Service No.	Series	Service Description	Reference Page
7005	10	Cut to Length	851
7051	10	Access Hole	855
7042	10	Anchor Counterbore	857
7061	10	Tap Profile End	853

1.00" X 1.00" Smooth Surface T-Slotted Profile - Two Opposite Open T-Slots

1004-S Profile

1004-S is a 1.00" x 1.00" fractional 10 series square T-slot profile with two opposite open T-slots, one on two 1.00" faces. The profile is smooth, which makes it resistant to dirt and debris buildup while also being easy to clean. The 1004-S profile is compatible with 10 series fasteners. The placement of the T-slots allows support structures or large panels to be easily placed into them.

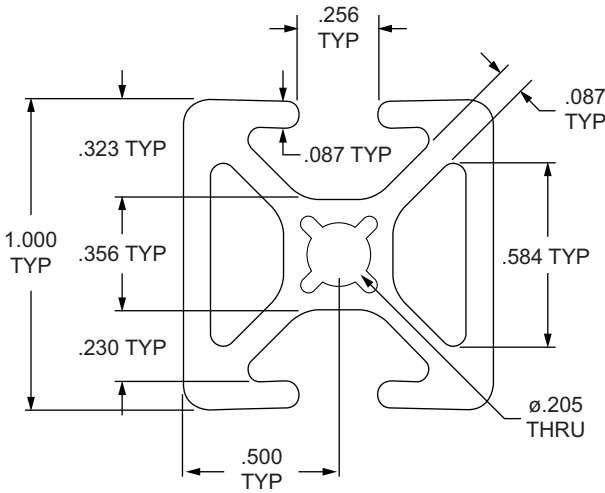

Part No.	Series	Stock Length	Material	Alloy**	Finish	Drop Lock	Moment of Inertia	Surface Area	Yield Strength	Modulus of Elasticity	Weight
1004-S *	10	145", 242"	Aluminum	6105-T5	Clear Anodize	2°	IX = 0.0563 ³⁴ IY = 0.0467 ³⁴	0.484 in. ²	35,000 psi	10,200,000 lb / in. ²	0.0470 lb / in.
1004-S-Black-FB		per inch			Black Anodize						

* The above profiles are sold per inch or stock length.

** Or comparable

Standard Machining Services

Service No.	Series	Service Description	Reference Page
7005	10	Cut to Length	851
7051	10	Access Hole	855
7042	10	Anchor Counterbore	857
7061	10	Tap Profile End	853

1004 Profile

1004 is a 1.00" x 1.00" fractional 10 series square T-slot profile with two opposite open T-slots, one on two 1.00" faces. The profile has align-a-grooves to assist in alignment when connecting profiles. The 1004 profile is compatible with 10 series fasteners. The placement of the T-slots allows support structures or large panels to be easily placed into them while lending itself to projects such as guarding, furniture or displays.

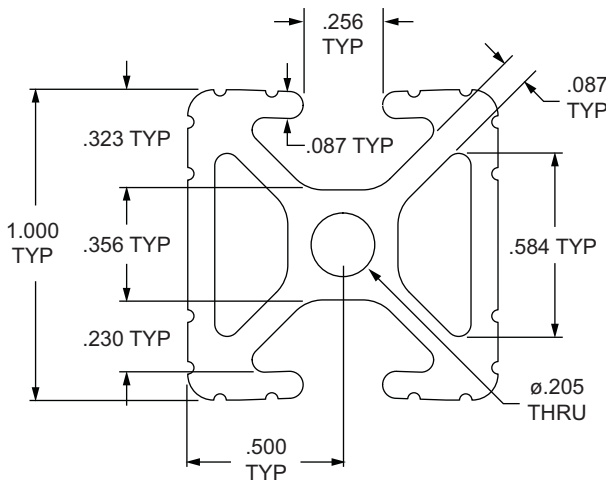

Part No.	Series	Stock Length	Material	Alloy**	Finish	Drop Lock	Moment of Inertia	Surface Area	Yield Strength	Modulus of Elasticity	Weight
1004 *	10	145", 242"	Aluminum	6105-T5	Clear Anodize	2°	IX = 0.0443 ⁱⁿ⁴ IY = 0.0541 ⁱⁿ⁴	0.482 in. ²	35,000 psi	10,200,000 lb / in. ²	0.0470 lb / in.
1004-Black-FB		per inch			Black Anodize						

* The above profiles are sold per inch or stock length.

** Or comparable

Standard Machining Services

Service No.	Series	Service Description	Reference Page
7005	10	Cut to Length	851
7051	10	Access Hole	855
7042	10	Anchor Counterbore	857
7061	10	Tap Profile End	853

1.00" X 1.00" Smooth Surface Quarter Round T-Slotted Profile - Two Open T-Slots

1012-S Profile

1012-S is a 1.00" x 1.00" fractional 10 series quarter round T-slot profile with a .750" radius curved back and two open T-slots, one on each of the 1.00" profile faces. The profile is smooth, which makes it resistant to dirt and debris buildup while also being easy to clean. The 1012-S profile is compatible with 10 series fasteners. This profile allows structures or large panels to be easily placed into the open T-slots.

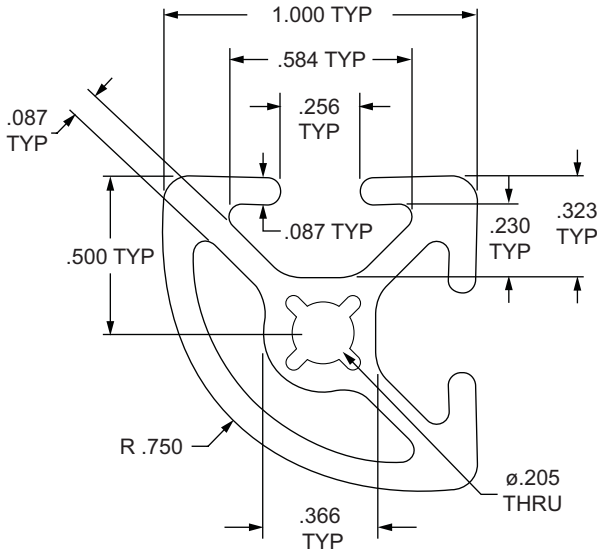

Part No.	Series	Stock Length	Material	Alloy**	Finish	Drop Lock	Moment of Inertia	Surface Area	Yield Strength	Modulus of Elasticity	Weight
1012-S *	10	145", 242"	Aluminum	6105-T5	Clear Anodize	2°	IX = 0.0414" ⁴ IY = 0.0414" ⁴	0.423 in. ²	35,000 psi	10,200,000 lb / in. ²	0.0411 lb / in.
1012-S-Black-FB		per inch			Black Anodize						

* The above profiles are sold per inch or stock length.

** Or comparable

Standard Machining Services

Service No.	Series	Service Description	Reference Page
7005	10	Cut to Length	851
7051	10	Access Hole	855
7042	10	Anchor Counterbore	857
7061	10	Tap Profile End	853

80/20® 1.00" X 1.00" Quarter Round T-Slotted Profile - Two Open T-Slots

1012 Profile

1012 is a 1.00" x 1.00" fractional 10 series quarter round T-slot profile with a .750" radius curved back and two open T-slots, one on each of the 1.00" profile faces. The profile has align-a-grooves to assist in aligning connecting profiles. The 1012 profile is compatible with 10 series fasteners. This profile allows structures or large panels to be easily placed into the open T-slots while lending itself to workstations, displays or exhibits.

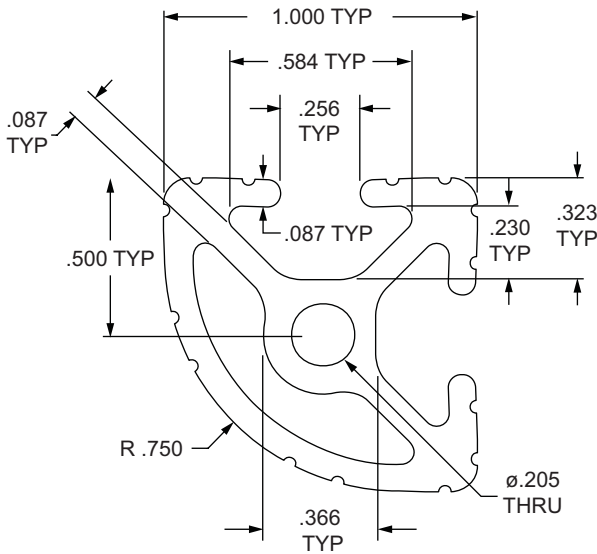

Part No.	Series	Stock Length	Material	Alloy**	Finish	Drop Lock	Moment of Inertia	Surface Area	Yield Strength	Modulus of Elasticity	Weight
1012 *	10	145", 242"	Aluminum	6105-T5	Clear Anodize	2°	IX = 0.0400" ⁴ IY = 0.0400" ⁴	0.423 in. ²	35,000 psi	10,200,000 lb / in. ²	0.0413 lb / in.
1012-Black-FB		per inch			Black Anodize						

* The above profiles are sold per inch or stock length.

** Or comparable

Standard Machining Services

Service No.	Series	Service Description	Reference Page
7005	10	Cut to Length	851
7051	10	Access Hole	855
7042	10	Anchor Counterbore	857
7061	10	Tap Profile End	853

1.00" X 0.50" T-Slotted Profile - Single Open T-Slot

1050 Profile

1050 is a 1.00" x 0.50" fractional 10 series rectangular T-slot profile with one open T-slot on one 1.00" face. The profile has align-a-grooves to assist in alignment when connecting profiles. The 1050 profile is compatible with 10 series fasteners. It is a thinner profile that connects easily to flat surfaces and works well as a supporting structure or spacer for mounting accessories such as handles, door tracks, rails, valves or sensors.

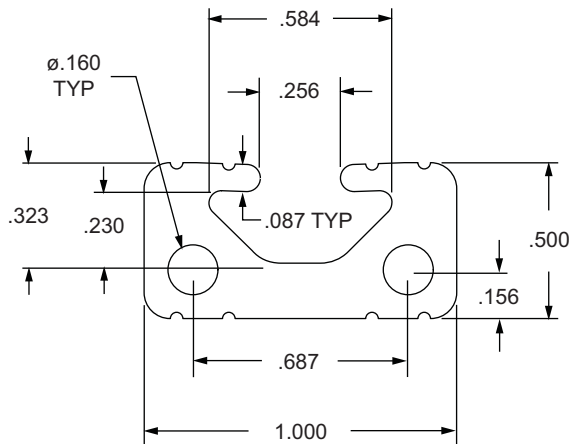

Part No.	Series	Stock Length	Material	Alloy**	Finish	Drop Lock	Moment of Inertia	Surface Area	Yield Strength	Modulus of Elasticity	Weight
1050 *	10	145"	Aluminum	6105-T5	Clear Anodize	2°	IX = 0.0074 ⁴⁴ IY = 0.0323 ⁴⁴	0.320 in. ²	35,000 psi	10,200,000 lb / in. ²	0.0312 lb / in.
1050-Black-FB		per inch			Black Anodize						

* The above profiles are sold per inch or stock length.

** Or comparable

Standard Machining Services

Service No.	Series	Service Description	Reference Page
7005	10	Cut to Length	851
7051	10	Access Hole	855
7042	10	Anchor Counterbore	857
7006	10	Tap Profile End	853
7256	10	Drill Thru & Counterbore	858

2012 Profile

2012 is a 2.00" x 0.50" fractional 10 series rectangular T-slot profile with two adjacent open T-slots on a 2.00" face. The profile has align-a-grooves to assist in alignment when connecting profiles. The 2012 profile is compatible with 10 series fasteners. It is a thinner profile that connects easily to flat surfaces and works well as a supporting structure or spacer for mounting accessories such as handles, door tracks, rails or valves.

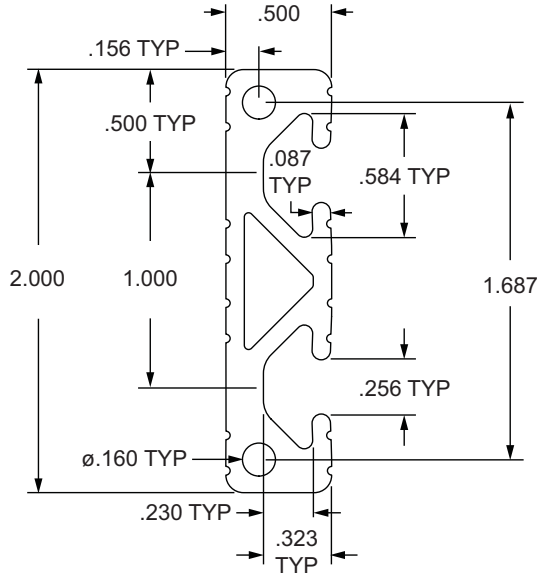

Part No.	Series	Stock Length	Material	Alloy**	Finish	Drop Lock	Moment of Inertia	Surface Area	Yield Strength	Modulus of Elasticity	Weight
2012 *	10	145"	Aluminum	6105-T5	Clear Anodize	2°	IX = 0.2253 ⁱⁿ ⁴ IY = 0.0146 ⁱⁿ ⁴	0.564 in. ²	35,000 psi	10,200,000 lb / in. ²	0.0550 lb / in.
2012-Black-FB		per inch			Black Anodize						

* The above profiles are sold per inch or stock length.

** Or comparable

Standard Machining Services

Service No.	Series	Service Description	Reference Page
7000	10	Cut to Length	851
7051	10	Access Hole	855
7042	10	Anchor Counterbore	857
7008	10	Tap Profile End	853
7256	10	Drill Thru & Counterbore	858

1.00" X 2.00" Smooth Surface T-Slotted Profile - Six Open T-Slots

1020-S Profile

1020-S is a 1.00" x 2.00" fractional 10 series rectangular T-slot profile with six open T-slots, one on each 1.00" face and two on each 2.00" face. The profile is smooth, which makes it resistant to dirt and debris buildup while also being easy to clean. The 1020-S profile is compatible with 10 series fasteners. The center cavity of the profile can be pressurized up to 150 psi, lending itself to work spaces, machine guards and panel mount racks.

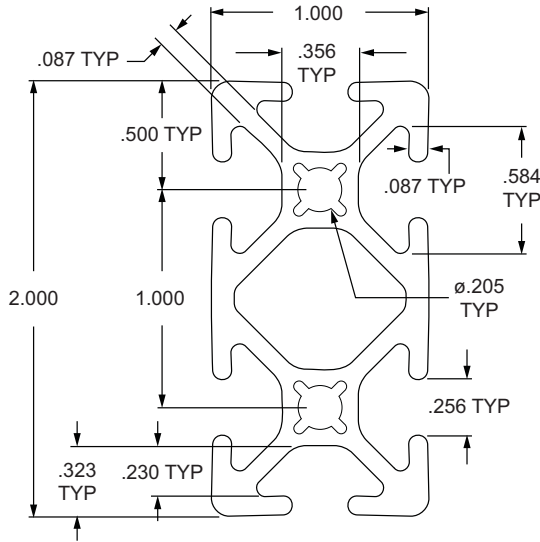

Part No.	Series	Stock Length	Material	Alloy**	Finish	Drop Lock	Moment of Inertia	Surface Area	Yield Strength	Modulus of Elasticity	Weight
1020-S *	10	145", 242"	Aluminum	6105-T5	Clear Anodize	2°	IX = 0.0863 ⁱⁿ⁴ IY = 0.3084 ⁱⁿ⁴	0.786 in. ²	35,000 psi	10,200,000 lb / in. ²	0.0763 lb / in.
1020-S-Black-FB		per inch			Black Anodize						

* The above profiles are sold per inch or stock length.

** Or comparable

Standard Machining Services

Service No.	Series	Service Description	Reference Page
7000	10	Cut to Length	851
7051	10	Access Hole	855
7042	10	Anchor Counterbore	857
7046	10	Tap Profile End	853

1020 Profile

1020 is a 1.00" x 2.00" fractional 10 series rectangular T-slot profile with six open T-slots, one on each 1.00" face and two on each 2.00" face. The profile has align-a-grooves to assist in alignment when connecting profiles. The 1020 profile is compatible with 10 series fasteners. The center cavity of the profile can be pressurized up to 150 psi, lending itself to work spaces, machine guards, displays and panel mount racks.

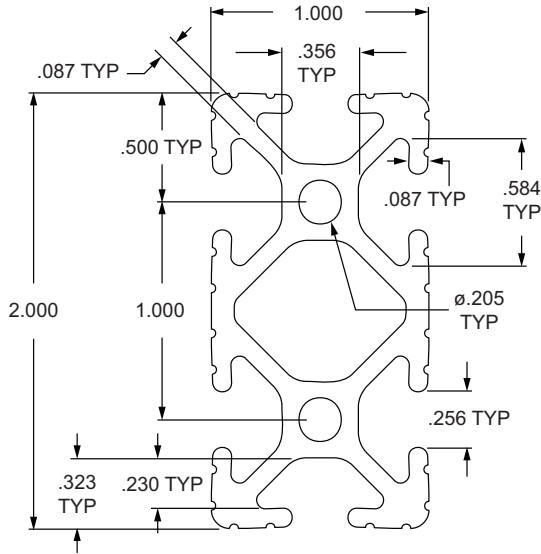

Part No.	Series	Stock Length	Material	Alloy**	Finish	Drop Lock	Moment of Inertia	Surface Area	Yield Strength	Modulus of Elasticity	Weight
1020 *		97", 145", 242"	Aluminum	6105-T5	Clear Anodize	2°	IX = 0.3078 ⁱⁿ⁴ IY = 0.0833 ⁱⁿ⁴	0.787 in. ²	35,000 psi	10,200,000 lb / in. ²	0.0768 lb / in.
1020-Black *	10	145"			Black Anodize						
1020-Black-FB		per inch			Black Anodize						

* The above profiles are sold per inch or stock length.

** Or comparable

Standard Machining Services

Service No.	Series	Service Description	Reference Page
7000	10	Cut to Length	851
7051	10	Access Hole	855
7042	10	Anchor Counterbore	857
7046	10	Tap Profile End	853

1.00" X 3.00" Smooth Surface T-Slotted Profile - Eight Open T-Slots

1030-S Profile

1030-S is a 1.00" x 3.00" fractional 10 series rectangular T-slot profile with eight open T-slots, one on each 1.00" face and three on each 3.00" face. The profile is smooth, which makes it resistant to dirt and debris buildup while also being easy to clean. The 1030-S profile is compatible with 10 series fasteners and has center cavities that can be pressurized up to 150 psi. The eight open T-slots make this profile great for mounting accessories, flat plates and hinges while the ability to pressurize it lends it to linear motion or machine frames.

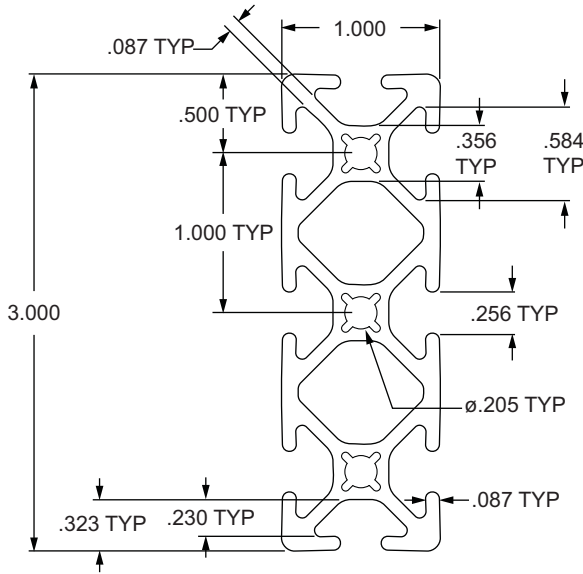

Part No.	Series	Stock Length	Material	Alloy**	Finish	Drop Lock	Moment of Inertia	Surface Area	Yield Strength	Modulus of Elasticity	Weight
1030-S*	10	145", 242"	Aluminum	6105-T5	Clear Anodize	2°	IX = 0.1262 ⁱⁿ ⁴ IY = 0.9599 ⁱⁿ ⁴	1.135 in. ²	35,000 psi	10,200,000 lb / in. ²	0.1101 lb / in.
1030-S-Black-FB		per inch			Black Anodize						

* The above profiles are sold per inch or stock length.

** Or comparable

Standard Machining Services

Service No.	Series	Service Description	Reference Page
7003	10	Cut to Length	851
7051	10	Access Hole	855
7042	10	Anchor Counterbore	857
7036	10	Tap Profile End	853

1030 Profile

1030 is a 1.00" x 3.00" fractional 10 series rectangular T-slot profile with eight open T-slots, one on each 1.00" face and three on each 3.00" face. The profile has align-a-grooves to assist in alignment when connecting profiles. The 1030 profile is compatible with 10 series fasteners and has center cavities that can be pressurized up to 150 psi. The eight open T-slots make this profile great for mounting accessories, flat plates and hinges while the ability to pressurize it lends it to projects involving linear motion or machine frames.

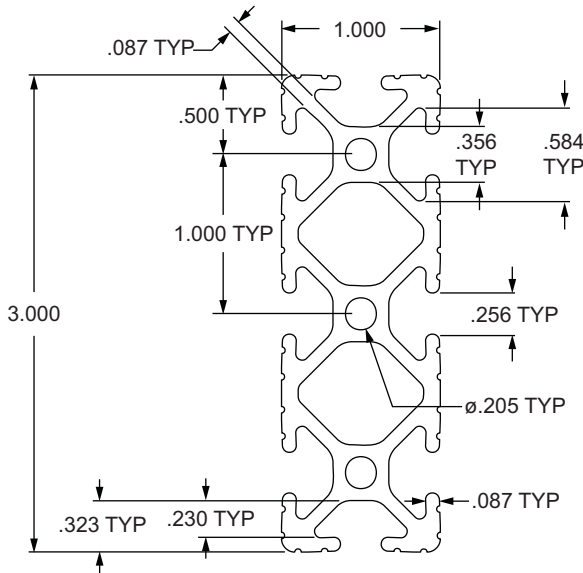

Part No.	Series	Stock Length	Material	Alloy**	Finish	Drop Lock	Moment of Inertia	Surface Area	Yield Strength	Modulus of Elasticity	Weight
1030 *	10	145", 242"	Aluminum	6105-T5	Clear Anodize	2°	IX = 0.9711 ⁱⁿ⁴ IY = 0.1238 ⁱⁿ⁴	1.140 in. ²	35,000 psi	10,200,000 lb / in. ²	0.1112 lb / in.
1030-Black-FB		per inch			Black Anodize						

* The above profiles are sold per inch or stock length.

** Or comparable

Standard Machining Services

Service No.	Series	Service Description	Reference Page
7003	10	Cut to Length	851
7051	10	Access Hole	855
7042	10	Anchor Counterbore	857
7036	10	Tap Profile End	853

2.00" X 2.00" Smooth Surface T-Slotted Profile - Eight Open T-Slots

2020-S Profile

2020-S is a 2.00" x 2.00" fractional 10 series square T-slot profile with eight open T-slots, two on each 2.00" face. The profile is smooth, which makes it resistant to dirt and debris buildup while also being easy to clean. The 2020-S profile is compatible with 10 series fasteners and has a center cavity that can be pressurized up to 150 psi. The eight open T-slots, strength, and ability to pressurize this profile make it a great choice for automation applications, machine frames and workstations.

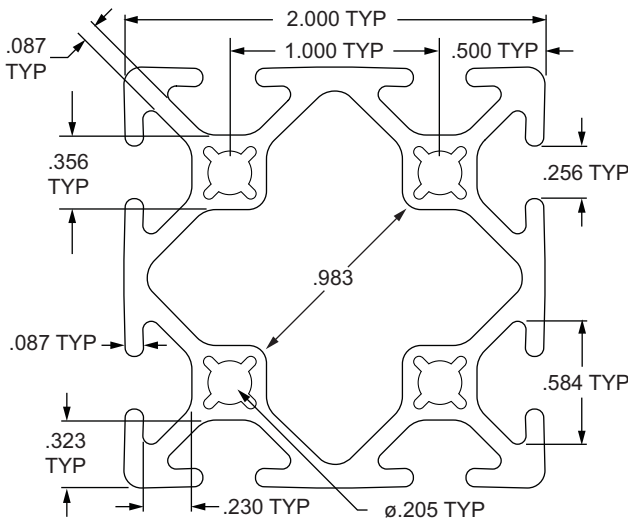

Part No.	Series	Stock Length	Material	Alloy**	Finish	Drop Lock	Moment of Inertia	Surface Area	Yield Strength	Modulus of Elasticity	Weight
2020-S*	10	145", 242"	Aluminum	6105-T5	Clear Anodize	2°	IX = 0.5545 ⁱⁿ⁴ IY = 0.5545 ⁱⁿ⁴	1.216 in. ²	35,000 psi	10,200,000 lb / in. ²	0.1179 lb / in.
2020-S-Black-FB		per inch			Black Anodize						

* The above profiles are sold per inch or stock length.

** Or comparable

Standard Machining Services

Service No.	Series	Service Description	Reference Page
7012	10	Cut to Length	851
7051	10	Access Hole	855
7042	10	Anchor Counterbore	857
7064	10	Tap Profile End	853

2020 Profile

2020 is a 2.00" x 2.00" fractional 10 series square T-slot profile with eight open T-slots, two on each 2.00" face. The profile has align-a-grooves to assist in alignment when connecting profiles. The 2020 profile is compatible with 10 series fasteners and has a center cavity that can be pressurized up to 150 psi. The eight open T-slots, strength, and ability to pressurize this profile make it a great choice for automation applications, machine frames and workstations.

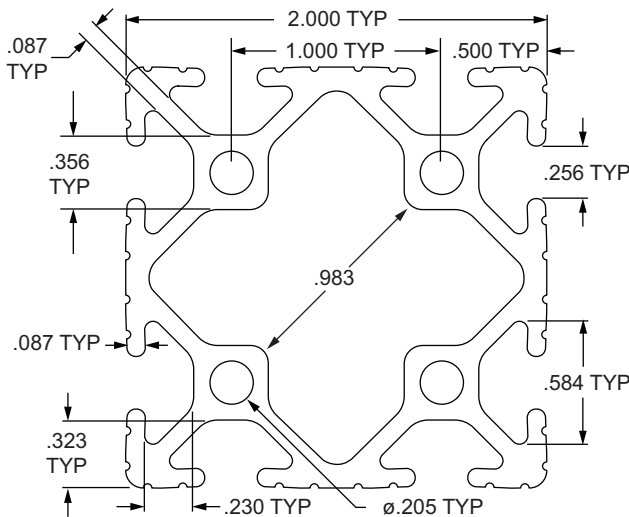

Part No.	Series	Stock Length	Material	Alloy**	Finish	Drop Lock	Moment of Inertia	Surface Area	Yield Strength	Modulus of Elasticity	Weight
2020 *	10	145", 242"	Aluminum	6105-T5	Clear Anodize	2°	IX = 0.5509 ⁱⁿ⁴ IY = 0.5509 ⁱⁿ⁴	1.228 in. ²	35,000 psi	10,200,000 lb / in. ²	0.1198 lb / in.
2020-Black *		145"			Black Anodize						
2020-Black-FB		per inch			Black Anodize						

* The above profiles are sold per inch or stock length.

** Or comparable

Standard Machining Services

Service No.	Series	Service Description	Reference Page
7012	10	Cut to Length	851
7051	10	Access Hole	855
7042	10	Anchor Counterbore	857
7064	10	Tap Profile End	853

2.00" X 4.00" Smooth Surface T-Slotted Profile - Twelve Open T-Slots

2040-S Profile

2040-S is a 2.00" x 4.00" fractional 10 series rectangular T-slot profile with twelve open T-slots, two on each 2.00" face and four on each 4.00" face. The profile is smooth, which makes it resistant to dirt and debris buildup while also being easy to clean. The 2040-S profile is compatible with 10 series fasteners and has center cavities that can be pressurized up to 150 psi. The twelve open T-slots, strength, and ability to pressurize this profile make it a great choice for automation applications, machine frames and workstations.

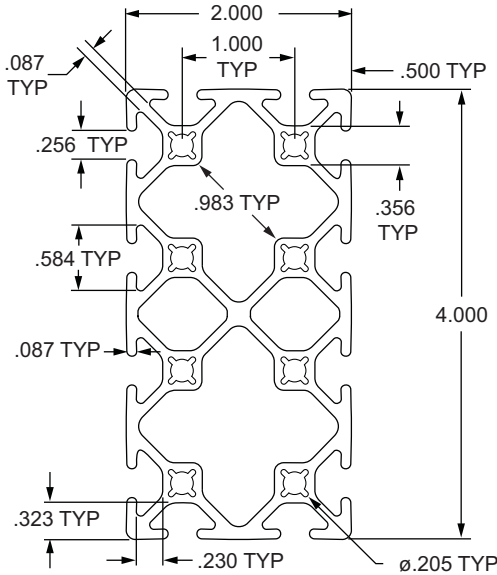

Part No.	Series	Stock Length	Material	Alloy**	Finish	Drop Lock	Moment of Inertia	Surface Area	Yield Strength	Modulus of Elasticity	Weight
2040-S*	10	145", 242"	Aluminum	6105-T5	Clear Anodize	2°	IX = 1.0543 ³⁴ IY = 3.5123 ³⁴	2.255 in. ²	35,000 psi	10,200,000 lb / in. ²	0.2188 lb / in.
2040-S-Black-FB		per inch			Black Anodize						

* The above profiles are sold per inch or stock length.

** Or comparable

Standard Machining Services

Service No.	Series	Service Description	Reference Page
7013	10	Cut to Length	851
7051	10	Access Hole	855
7042	10	Anchor Counterbore	857
7038	10	Tap Profile End	853

2040 Profile

2040 is a 2.00" x 4.00" fractional 10 series rectangular T-slot profile with twelve open T-slots, two on each 2.00" face and four on each 4.00" face. The profile has align-a-grooves to assist in alignment when connecting profiles. The 2040 profile is compatible with 10 series fasteners and has center cavities that can be pressurized up to 150 psi. The twelve open T-slots, strength, and ability to pressurize this profile make it a great choice for automation applications, machine frames and workstations.

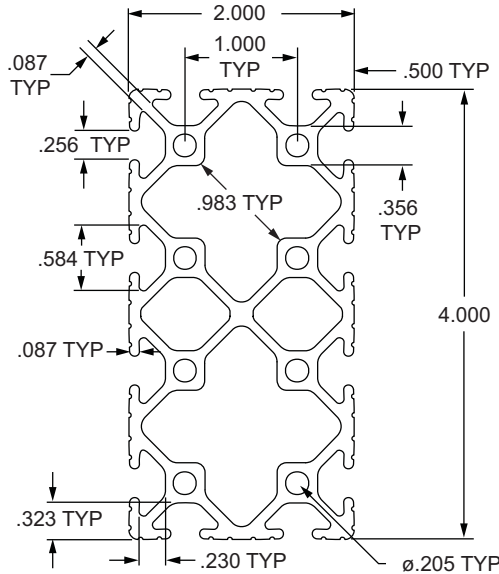

Part No.	Series	Stock Length	Material	Alloy**	Finish	Drop Lock	Moment of Inertia	Surface Area	Yield Strength	Modulus of Elasticity	Weight
2040 *	10	145", 242"	Aluminum	6105-T5	Clear Anodize	2°	IX = 3.5168 ⁱⁿ⁴ IY = 1.0513 ⁱⁿ⁴	2.290 in. ²	35,000 psi	10,200,000 lb / in. ²	0.2233 lb / in.
2040-Black-FB		per inch			Black Anodize						

* The above profiles are sold per inch or stock length.

** Or comparable

Standard Machining Services

Service No.	Series	Service Description	Reference Page
7013	10	Cut to Length	851
7051	10	Access Hole	855
7042	10	Anchor Counterbore	857
7038	10	Tap Profile End	853

1.50" X 1.50" Ultra-Lite Smooth Surface T-Slotted Profile - Four Open T-Slots

1515-ULS Profile

1515-ULS is a 1.50" x 1.50" ultra-lite fractional 15 series square T-slot profile with four open T-slots, one on each 1.50" face. The profile is smooth, which makes it resistant to dirt and debris buildup while also being easy to clean. The 1515-ULS profile is compatible with all 15 series fasteners. This profile lends itself to clean room applications, guards, enclosures, or workstations. The four open T-slots enable access from any direction and are useful for mounting accessories.

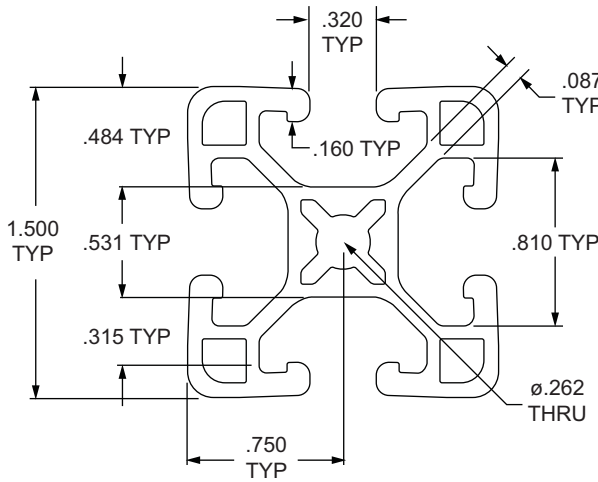

Part No.	Series	Stock Length	Material	Alloy**	Finish	Drop Lock	Moment of Inertia	Surface Area	Yield Strength	Modulus of Elasticity	Weight
1515-ULS *		145", 242"	Aluminum	6105-T5	Clear Anodize	2°	IX = 0.1765 ⁱⁿ⁴ IY = 0.1765 ⁱⁿ⁴	2.290 in. ²	35,000 psi	10,200,000 lb / in. ²	0.0790 lb / in.
1515-ULS-Black *	15	145"			Black Anodize						
1515-ULS-Black-FB		per inch			Black Anodize						

* The above profiles are sold per inch or stock length.

** Or comparable

Standard Machining Services

Service No.	Series	Service Description	Reference Page
7010	15	Cut to Length	851
7050	15	Access Hole	855
7040	15	Anchor Counterbore	857
7060	15	Tap Profile End	853

1515-UL Profile

1515-UL is a 1.50" x 1.50" ultra-lite fractional 15 series square T-slot profile with four open T-slots, one on each 1.50" face. The profile has align-a-grooves to assist in alignment when connecting profiles. The 1515-UL profile is compatible with all 15 series fasteners. The 1515-UL profile is the lightest in the 1515 profile family and lends itself to machine guards, sound enclosures, work benches, panel mount racks or displays. The four open T-slots enable access from any direction and are useful for mounting accessories.

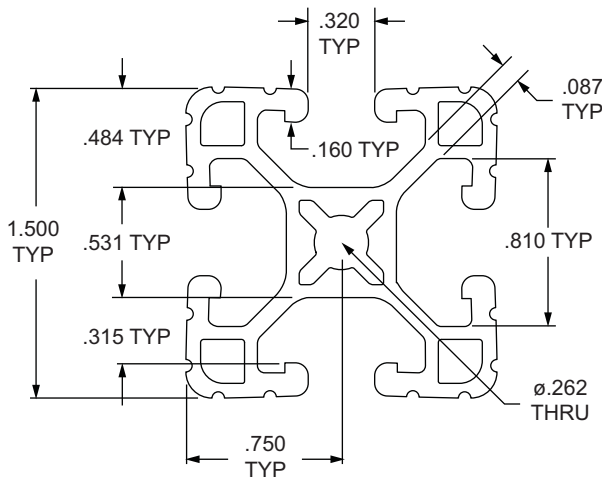

Part No.	Series	Stock Length	Material	Alloy**	Finish	Drop Lock	Moment of Inertia	Surface Area	Yield Strength	Modulus of Elasticity	Weight
1515-UL *	15	145", 242"	Aluminum	6105-T5	Clear Anodize	2°	IX = 0.1772 ⁱⁿ⁴ IY = 0.1772 ⁱⁿ⁴	0.787 in. ²	35,000 psi	10,200,000 lb / in. ²	0.0768 lb / in.
1515-UL-Black *		145"			Black Anodize						
1515-UL-Black-FB		per inch			Black Anodize						

* The above profiles are sold per inch or stock length.

** Or comparable

Standard Machining Services

Service No.	Series	Service Description	Reference Page
7010	15	Cut to Length	851
7050	15	Access Hole	855
7040	15	Anchor Counterbore	857
7060	15	Tap Profile End	853

1.50" X 1.50" Lite Smooth Surface T-Slotted Profile - Four Open T-Slots

1515-LS Profile

1515-LS is a 1.50" x 1.50" lite fractional 15 series square T-slot profile with four open T-slots, one on each 1.50" face. The profile is smooth, which makes it resistant to dirt and debris buildup while also being easy to clean. The 1515-LS profile is compatible with all 15 series fasteners. This profile lends itself to clean room applications, guards, enclosures, or workstations. The four open T-slots enable access from any direction and are useful for mounting accessories.

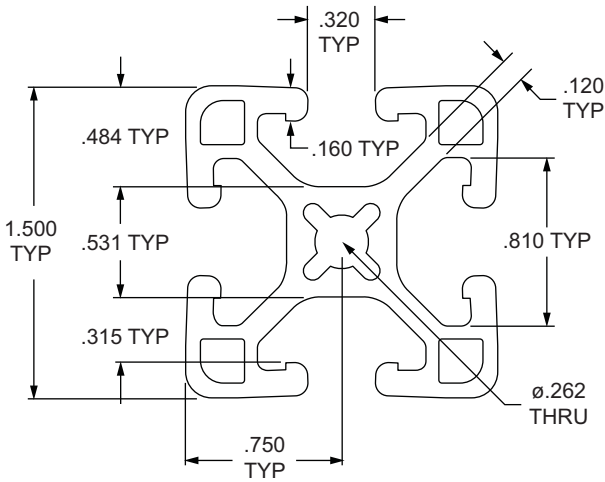

Part No.	Series	Stock Length	Material	Alloy**	Finish	Drop Lock	Moment of Inertia	Surface Area	Yield Strength	Modulus of Elasticity	Weight
1515-LS *		145", 242"	Aluminum	6105-T5	Clear Anodize	2°	IX = 0.1921 ⁱⁿ⁴ IY = 0.1921 ⁱⁿ⁴	0.882 in. ²	35,000 psi	10,200,000 lb / in. ²	0.0860 lb / in.
1515-LS-Black *	15	145"			Black Anodize						
1515-LS-Black-FB		per inch			Black Anodize						

* The above profiles are sold per inch or stock length.

** Or comparable

Standard Machining Services

Service No.	Series	Service Description	Reference Page
7010	15	Cut to Length	851
7050	15	Access Hole	855
7040	15	Anchor Counterbore	857
7060	15	Tap Profile End	853

1515-Lite Profile

1515-Lite is a 1.50" x 1.50" lite fractional 15 series square T-slot profile with four open T-slots, one on each 1.50" face. The profile has align-a-grooves to assist in alignment when connecting profiles. The 1515-Lite profile is compatible with all 15 series fasteners. This profile lends itself to machine guards, enclosures or work benches. The four open T-slots enable access from any direction and are useful for mounting accessories.

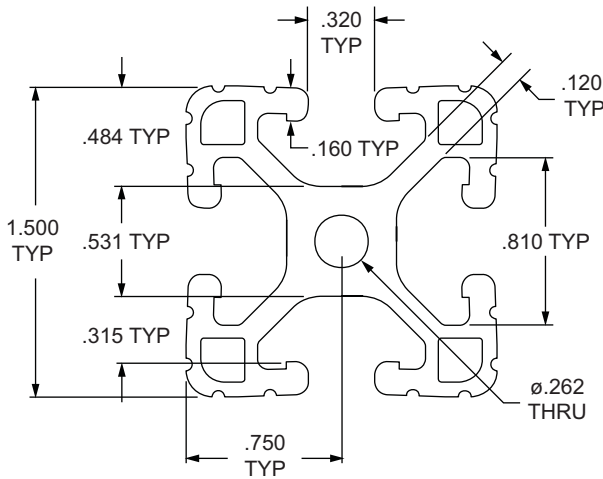

Part No.	Series	Stock Length	Material	Alloy**	Finish	Drop Lock	Moment of Inertia	Surface Area	Yield Strength	Modulus of Elasticity	Weight
1515-Lite *	15	97", 145", 242"	Aluminum	6105-T5	Clear Anodize	2°	IX = 0.1853 ^{m4} IY = 0.1853 ^{m4}	0.896 in. ²	35,000 psi	10,200,000 lb / in. ²	0.0873 lb / in.
1515-Lite-Black *		145"			Black Anodize						
1515-Lite-Black-FB		per inch			Black Anodize						
1515-Lite-Yellow *		145"			Yellow Powder Coat						

* The above profiles are sold per inch or stock length.

** Or comparable

Standard Machining Services

Service No.	Series	Service Description	Reference Page
7010	15	Cut to Length	851
7050	15	Access Hole	855
7040	15	Anchor Counterbore	857
7060	15	Tap Profile End	853

1.50" X 1.50" Smooth Surface T-Slotted Profile - Four Open T-Slots

1515-S Profile

1515-S is a 1.50" x 1.50" fractional 15 series square T-slot profile with four open T-slots, one on each 1.50" face. The profile is smooth, which makes it resistant to dirt and debris buildup while also being easy to clean. The 1515-S profile is compatible with all 15 series fasteners. This profile is the most heavy-duty in the 1515 profile family and lends itself to clean room applications, guards, enclosures, or workstations.

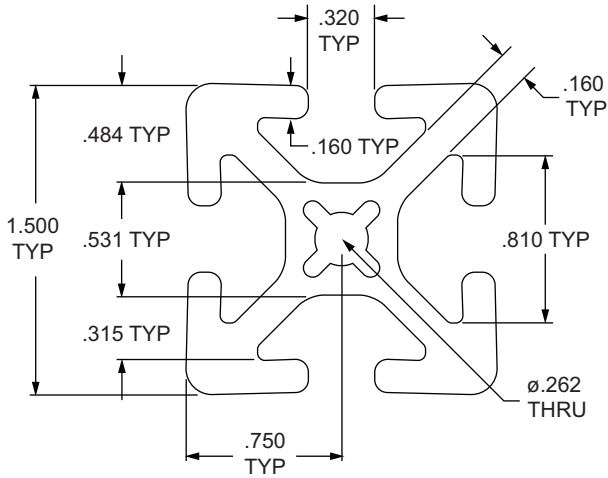

Part No.	Series	Stock Length	Material	Alloy**	Finish	Drop Lock	Moment of Inertia	Surface Area	Yield Strength	Modulus of Elasticity	Weight
1515-S *	15	145", 242"	Aluminum	6105-T5	Clear Anodize	2°	IX = 0.2631 ¹⁴ IY = 0.2631 ¹⁴	1.138 in. ²	35,000 psi	10,200,000 lb / in. ²	0.1109 lb / in.
1515-S-Black *		145"			Black Anodize						
1515-S-Black-FB		per inch			Black Anodize						

* The above profiles are sold per inch or stock length.

** Or comparable

Standard Machining Services

Service No.	Series	Service Description	Reference Page
7010	15	Cut to Length	851
7050	15	Access Hole	855
7040	15	Anchor Counterbore	857
7060	15	Tap Profile End	853

80/20[®] Inc. 1.50" X 1.50" T-Slotted Profile - Four Open T-Slots

1515 Profile

1515 is a 1.50" x 1.50" fractional 15 series square T-slot profile with four open T-slots, one on each 1.50" face. The profile has align-a-grooves to assist in alignment when connecting profiles. The 1515 profile is compatible with all 15 series fasteners. This profile is the most heavy-duty in the 1515 profile family and lends itself to machine frames, guarding applications, enclosures, or desks.

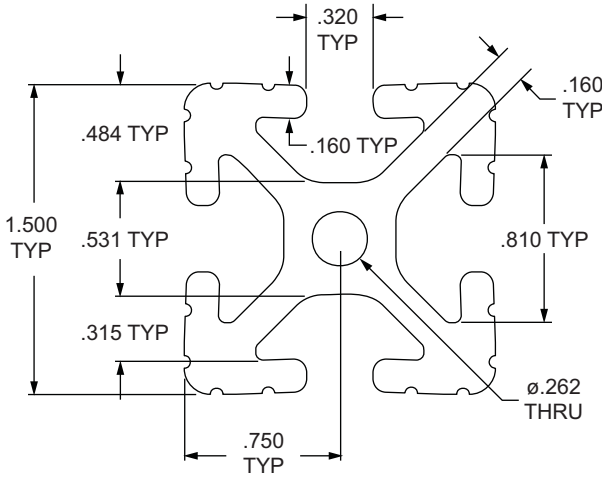

Part No.	Series	Stock Length	Material	Alloy**	Finish	Drop Lock	Moment of Inertia	Surface Area	Yield Strength	Modulus of Elasticity	Weight
1515 *	15	97", 145", 242"	Aluminum	6105-T5	Clear Anodize	2°	IX = 0.2542 ⁱⁿ⁴ IY = 0.2542 ⁱⁿ⁴	1.152 in. ²	35,000 psi	10,200,000 lb / in. ²	0.1123 lb / in.
1515-Black *		145"			Black Anodize						
1515-Black-FB		per inch			Black Anodize						

* The above profiles are sold per inch or stock length.

** Or comparable

Standard Machining Services

Service No.	Series	Service Description	Reference Page
7010	15	Cut to Length	851
7050	15	Access Hole	855
7040	15	Anchor Counterbore	857
7060	15	Tap Profile End	853

1.50" X 1.50" Lite Smooth Surface T-Slotted Profile - Single Open T-Slot

1501-LS Profile

1501-LS is a 1.50" x 1.50" lite fractional 15 series square T-slot profile with one open T-slot on one 1.50" face. The profile is smooth, which makes it resistant to dirt and debris buildup while also being easy to clean. The 1501-LS profile is compatible with 15 series fasteners. The three closed faces on this profile provide a clean, aesthetic look and lends itself to furniture, displays, desks, trade show booths, or retail kiosks.

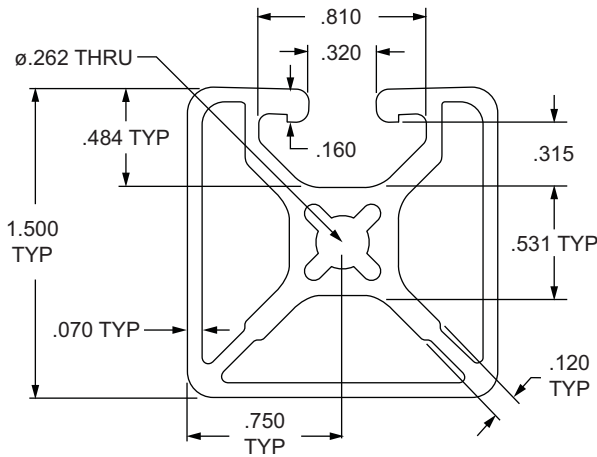

Part No.	Series	Stock Length	Material	Alloy**	Finish	Drop Lock	Moment of Inertia	Surface Area	Yield Strength	Modulus of Elasticity	Weight
1501-LS *	15	145", 242"	Aluminum	6105-T5	Clear Anodize	2°	IX = 0.1820 ^{in⁴} IY = 0.1799 ^{in⁴}	0.815 in. ²	35,000 psi	10,200,000 lb / in. ²	0.0788 lb / in.
1501-LS-Black-FB		per inch			Black Anodize						

* The above profiles are sold per inch or stock length.

** Or comparable

Standard Machining Services

Service No.	Series	Service Description	Reference Page
7010	15	Cut to Length	851
7050	15	Access Hole	855
7040	15	Anchor Counterbore	857
7060	15	Tap Profile End	853

1501 Profile

1501 is a 1.50" x 1.50" fractional 15 series square T-slot profile with one open T-slot on one 1.50" face. The profile has align-a-grooves to assist in alignment when connecting profiles. The 1501 profile is compatible with 15 series fasteners. The three closed faces on this profile provide a clean, aesthetic look and lends itself to furniture, displays, desks, trade show booths, or retail kiosks.

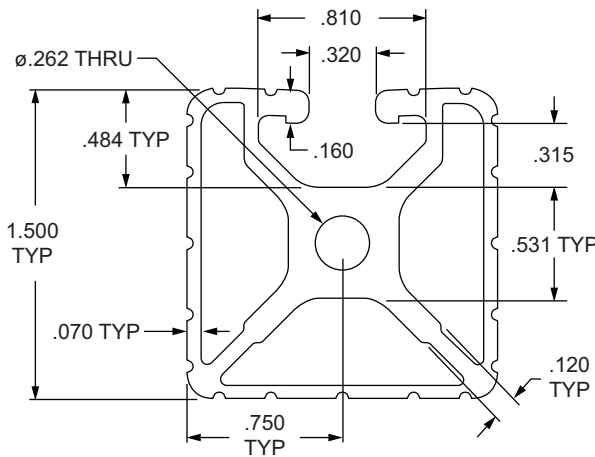

Part No.	Series	Stock Length	Material	Alloy**	Finish	Drop Lock	Moment of Inertia	Surface Area	Yield Strength	Modulus of Elasticity	Weight
1501 *	15	145", 242"	Aluminum	6105-T5	Clear Anodize	2°	IX = 0.1726 ^{m4} IY = 0.1694 ^{m4}	0.826 in. ²	35,000 psi	10,200,000 lb / in. ²	0.0805 lb / in.
1501-Black-FB		per inch			Black Anodize						

* The above profiles are sold per inch or stock length.

** Or comparable

Standard Machining Services

Service No.	Series	Service Description	Reference Page
7010	15	Cut to Length	851
7050	15	Access Hole	855
7040	15	Anchor Counterbore	857
7060	15	Tap Profile End	853

1.50" X 1.50" Lite Smooth Surface T-Slotted Profile - Two Adjacent Open T-Slots

1502-LS Profile

1502-LS is a 1.50" x 1.50" lite fractional 15 series square T-slot profile with two adjacent open T-slots, one on two 1.50" faces. The profile is smooth, which makes it resistant to dirt and debris buildup while also being easy to clean. The 1502-LS profile is compatible with 15 series fasteners. The two closed faces on this profile provide a clean, aesthetic look and lends itself to furniture, displays, desks, trade show booths, or retail kiosks.

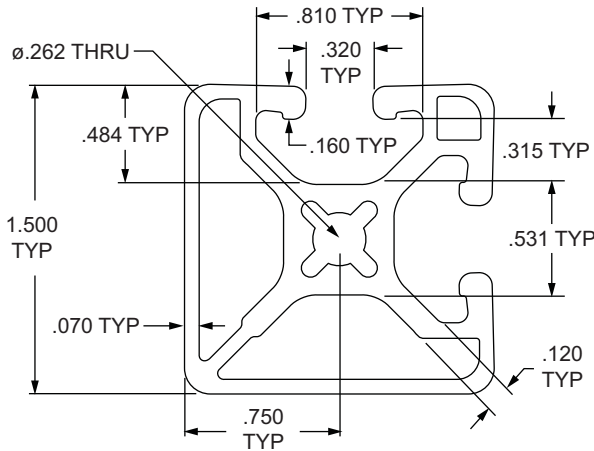

Part No.	Series	Stock Length	Material	Alloy**	Finish	Drop Lock	Moment of Inertia	Surface Area	Yield Strength	Modulus of Elasticity	Weight
1502-LS *	15	145", 242"	Aluminum	6105-T5	Clear Anodize	2°	IX = 0.1834 ^{in⁴} IY = 0.1834 ^{in⁴}	0.832 in. ²	35,000 psi	10,200,000 lb / in. ²	0.0811 lb / in.
1502-LS-Black-FB		per inch			Black Anodize						

* The above profiles are sold per inch or stock length.

** Or comparable

Standard Machining Services

Service No.	Series	Service Description	Reference Page
7010	15	Cut to Length	851
7050	15	Access Hole	855
7040	15	Anchor Counterbore	857
7060	15	Tap Profile End	853

1502 Profile

1502 is a 1.50" x 1.50" fractional 15 series square T-slot profile with two adjacent open T-slots, one on two 1.50" faces. The profile has align-a-grooves to assist in alignment when connecting profiles. The 1502 profile is compatible with 15 series fasteners. The two closed faces on this profile provide a clean, aesthetic look and lends itself to furniture, displays, desks, trade show booths, or retail kiosks.

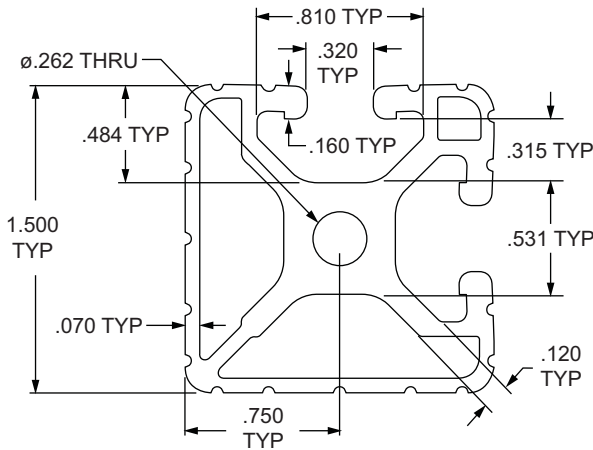

Part No.	Series	Stock Length	Material	Alloy**	Finish	Drop Lock	Moment of Inertia	Surface Area	Yield Strength	Modulus of Elasticity	Weight
1502 *	15	145", 242"	Aluminum	6105-T5	Clear Anodize	2°	IX = 0.1660 ⁱⁿ⁴ IY = 0.1730 ⁱⁿ⁴	0.844 in. ²	35,000 psi	10,200,000 lb / in. ²	0.0823 lb / in.
1502-Black-FB		per inch			Black Anodize						

* The above profiles are sold per inch or stock length.

** Or comparable

Standard Machining Services

Service No.	Series	Service Description	Reference Page
7010	15	Cut to Length	851
7050	15	Access Hole	855
7040	15	Anchor Counterbore	857
7060	15	Tap Profile End	853

1.50" X 1.50" Lite Smooth Surface T-Slotted Profile - Three Adjacent Open T-Slots

1503-LS Profile

1503-LS is a 1.50" x 1.50" lite fractional 15 series square T-slot profile with three adjacent open T-slots, one on three 1.50" faces. The profile is smooth, which makes it resistant to dirt and debris buildup while also being easy to clean. The 1503-LS profile is compatible with 15 series fasteners. The closed face on this profile provides a clean, aesthetic look and lends itself to work spaces, displays, or retail kiosks.

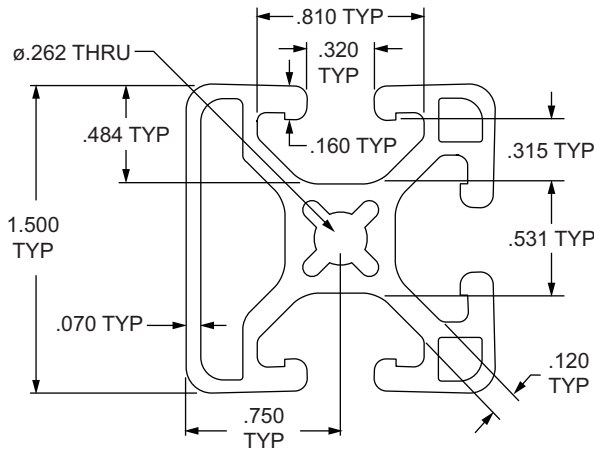

Part No.	Series	Stock Length	Material	Alloy**	Finish	Drop Lock	Moment of Inertia	Surface Area	Yield Strength	Modulus of Elasticity	Weight
1503-LS *	15	145", 242"	Aluminum	6105-T5	Clear Anodize	2°	IX = 0.1859 ⁱⁿ⁴ IY = 0.1840 ⁱⁿ⁴	0.848 in. ²	35,000 psi	10,200,000 lb / in. ²	0.0827 lb / in.
1503-LS-Black-FB		per inch			Black Anodize						

* The above profiles are sold per inch or stock length.

** Or comparable

Standard Machining Services

Service No.	Series	Service Description	Reference Page
7010	15	Cut to Length	851
7050	15	Access Hole	855
7040	15	Anchor Counterbore	857
7060	15	Tap Profile End	853

1503 Profile

1503 is a 1.50" x 1.50" fractional 15 series square T-slot profile with three adjacent open T-slots, one on three 1.50" faces. The profile has align-a-grooves to assist in alignment when connecting profiles. The 1503 profile is compatible with 15 series fasteners. The closed face on this profile provides a clean, aesthetic look and lends itself to work spaces, displays, or retail kiosks.

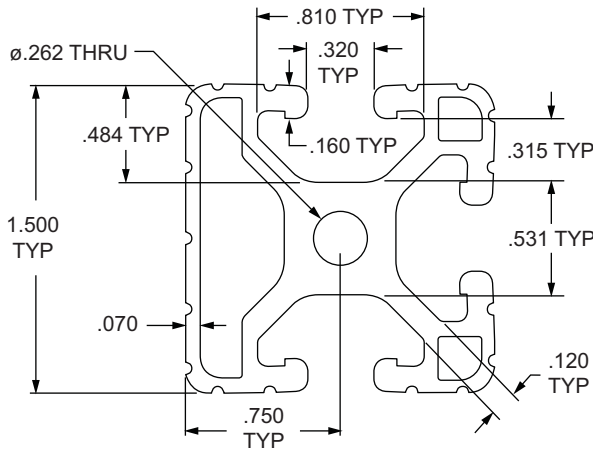

Part No.	Series	Stock Length	Material	Alloy**	Finish	Drop Lock	Moment of Inertia	Surface Area	Yield Strength	Modulus of Elasticity	Weight
1503 *	15	145", 242"	Aluminum	6105-T5	Clear Anodize	2°	IX = 0.1760 ⁱⁿ⁴ IY = 0.1790 ⁱⁿ⁴	0.862 in. ²	35,000 psi	10,200,000 lb / in. ²	0.0840 lb / in.
1503-Black-FB		per inch			Black Anodize						

* The above profiles are sold per inch or stock length.

** Or comparable

Standard Machining Services

Service No.	Series	Service Description	Reference Page
7010	15	Cut to Length	851
7050	15	Access Hole	855
7040	15	Anchor Counterbore	857
7060	15	Tap Profile End	853

1.50" X 1.50" Lite Smooth Surface T-Slotted Profile - Two Opposite Open T-Slots

1504-LS Profile

1504-LS is a 1.50" x 1.50" lite fractional 15 series square T-slot profile with two opposite open T-slots, one on two 1.50" faces. The profile is smooth, which makes it resistant to dirt and debris buildup while also being easy to clean. The 1504-LS profile is compatible with 15 series fasteners. The placement of the T-slots allow support structures or panels to be easily placed into them and lends itself to guarding, furniture or displays.

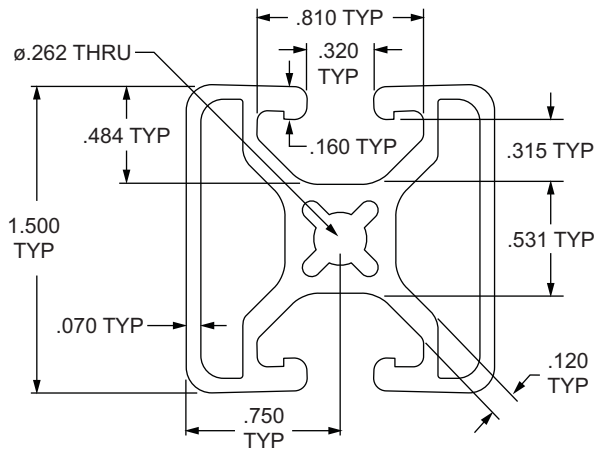

Part No.	Series	Stock Length	Material	Alloy**	Finish	Drop Lock	Moment of Inertia	Surface Area	Yield Strength	Modulus of Elasticity	Weight
1504-LS *	15	145", 242"	Aluminum	6105-T5	Clear Anodize	2°	IX = 0.1796 ^{in⁴} IY = 0.1759 ^{in⁴}	0.815 in. ²	35,000 psi	10,200,000 lb / in. ²	0.0795 lb / in.
1504-LS-Black-FB		per inch			Black Anodize						

* The above profiles are sold per inch or stock length.

** Or comparable

Standard Machining Services

Service No.	Series	Service Description	Reference Page
7010	15	Cut to Length	851
7050	15	Access Hole	855
7040	15	Anchor Counterbore	857
7060	15	Tap Profile End	853

1.50" X 1.50" 45 Degree Closed Side T-Slotted Profile - Two Adjacent Open T-Slots

1547 Profile

1547 is a 1.50" x 1.50" fractional 15 series 45 degree closed back T-slot profile with two open T-slots, one on each of the 1.50" profile faces. The profile has align-a-grooves to assist in alignment when connecting profiles. The 1547 profile is compatible with 15 series fasteners. This profile lends itself to workstations and displays because panels or other support structures can be easily placed in the T-slots.

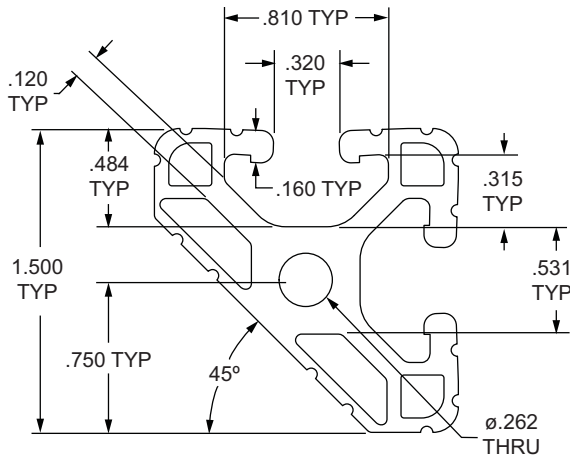

Part No.	Series	Stock Length	Material	Alloy**	Finish	Drop Lock	Moment of Inertia	Surface Area	Yield Strength	Modulus of Elasticity	Weight
1547 *	15	145", 242"	Aluminum	6105-T5	Clear Anodize	2°	IX = 0.1365 ⁱⁿ⁴ IY = 0.1365 ⁱⁿ⁴	0.740 in. ²	35,000 psi	10,200,000 lb / in. ²	0.0723 lb / in.
1547-Black-FB		per inch			Black Anodize						

* The above profiles are sold per inch or stock length.

** Or comparable

Standard Machining Services

Service No.	Series	Service Description	Reference Page
7010	15	Cut to Length	851
7050	15	Access Hole	855
7040	15	Anchor Counterbore	857
7060	15	Tap Profile End	853

Choose the Right Profile for Your Project.

You have a lot of choices when it comes to 80/20 T-slotted aluminum profiles. To help you narrow down your options, take advantage of the 80/20 **Profile Selector** on 8020.net to select the best profile for your needs.



8020.net/profile-selector

1.50" X 1.50" Lite Smooth Surface Quarter Round T-Slotted Profile - Two Open T-Slots

1517-LS Profile

1517-LS is a 1.50" x 1.50" lite fractional 15 series quarter round T-slot profile with a 1.123" radius curved back and two open T-slots, one on each of the 1.50" profile faces. The profile is smooth, which makes it resistant to dirt and debris buildup while also being easy to clean. The 1517-LS profile is compatible with 15 series fasteners. This profile lends itself to large workstations and displays because it provides an aesthetic appearance and panels or other support structures can be easily placed in the T-slots.

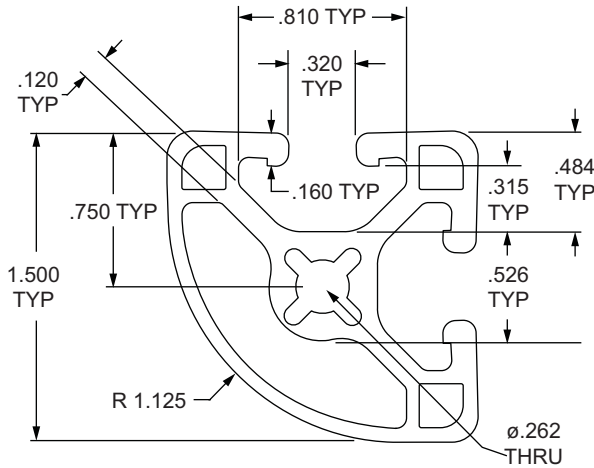

Part No.	Series	Stock Length	Material	Alloy**	Finish	Drop Lock	Moment of Inertia	Surface Area	Yield Strength	Modulus of Elasticity	Weight
1517-LS *	15	145"	Aluminum	6105-T5	Clear Anodize	2°	IX = 0.1686" ⁴ IY = 0.1686" ⁴	0.748 in. ²	35,000 psi	10,200,000 lb / in. ²	0.0729 lb / in.
1517-LS-Black-FB		per inch			Black Anodize						

* The above profiles are sold per inch or stock length.

** Or comparable

Standard Machining Services

Service No.	Series	Service Description	Reference Page
7010	15	Cut to Length	851
7050	15	Access Hole	855
7040	15	Anchor Counterbore	857
7060	15	Tap Profile End	853

80/20® 1.50" X 1.50" Quarter Round T-Slotted Profile - Two Open T-Slots

1517 Profile

1517 is a 1.50" x 1.50" fractional 15 series quarter round T-slot profile with a 1.123" radius curved back and two open T-slots, one on each of the 1.50" profile faces. The profile has align-a-grooves to assist in alignment when connecting profiles. The 1517 profile is compatible with 15 series fasteners. This profile lends itself to large workstations and displays because it provides an aesthetic appearance and panels or other support structures can be easily placed in the T-slots.

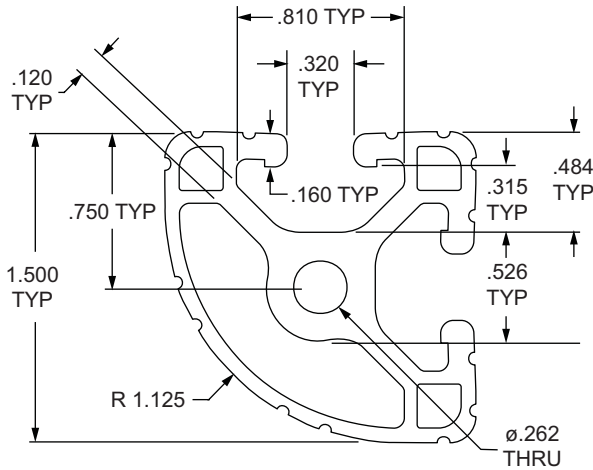

Part No.	Series	Stock Length	Material	Alloy**	Finish	Drop Lock	Moment of Inertia	Surface Area	Yield Strength	Modulus of Elasticity	Weight
1517 *	15	97", 145", 242"	Aluminum	6105-T5	Clear Anodize	2°	IX = 0.1662 ⁱⁿ⁴ IY = 0.1662 ⁱⁿ⁴	0.765 in. ²	35,000 psi	10,200,000 lb / in. ²	0.0746 lb / in.
1517-Black-FB		per inch			Black Anodize						

* The above profiles are sold per inch or stock length.

** Or comparable

Standard Machining Services

Service No.	Series	Service Description	Reference Page
7010	15	Cut to Length	851
7050	15	Access Hole	855
7040	15	Anchor Counterbore	857
7060	15	Tap Profile End	853

1.50" X .75" Smooth Surface T-Slotted Profile - Single Open T-Slot

1575 Profile

1575 is a 1.50" x 0.75" fractional 15 series rectangular T-slot profile with one open T-slot on one 1.50" face. The profile is smooth, which makes it resistant to dirt and debris buildup while also being easy to clean. The 1575 profile is compatible with 15 series fasteners. It is a thinner profile that connects easily to flat surfaces and works well as a supporting structure or spacer for mounting accessories such as handles, door tracks, rails, valves or sensors.

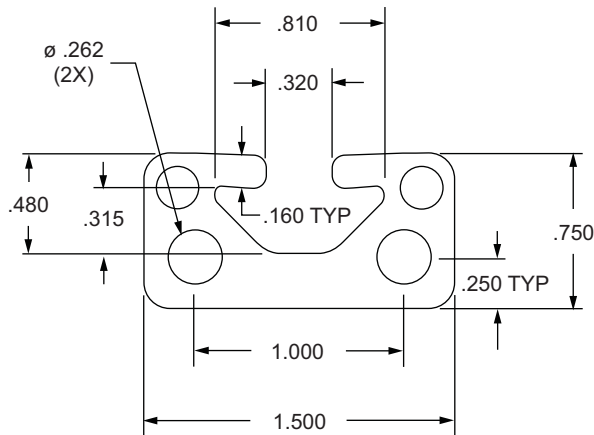

Part No.	Series	Stock Length	Material	Alloy**	Finish	Drop Lock	Moment of Inertia	Surface Area	Yield Strength	Modulus of Elasticity	Weight
1575 *	15	145", 242"	Aluminum	6105-T5	Clear Anodize	2°	IX = 0.0380 ⁱⁿ⁴ IY = 0.1470 ⁱⁿ⁴	0.686 in. ²	35,000 psi	10,200,000 lb / in. ²	0.0669 lb / in.
1575-Black-FB		per inch			Black Anodize						

* The above profiles are sold per inch or stock length.

** Or comparable

Standard Machining Services

Service No.	Series	Service Description	Reference Page
7010	15	Cut to Length	851
7050	15	Access Hole	855
7040	15	Anchor Counterbore	857
7014	15	Tap Profile End	853
7257	15	Drill Thru & Counterbore	858

1534-Lite Profile

1534-Lite is a 1.50" x 0.75" lite fractional 15 series rectangular T-slot profile with one open T-slot on one 1.50" face. The profile has align-a-grooves to assist in alignment when connecting profiles. The 1534-Lite profile is compatible with 15 series fasteners. It is a thinner profile that connects easily to flat surfaces and works well as a supporting structure or spacer for mounting accessories such as handles, door tracks, rails, valves or sensors.

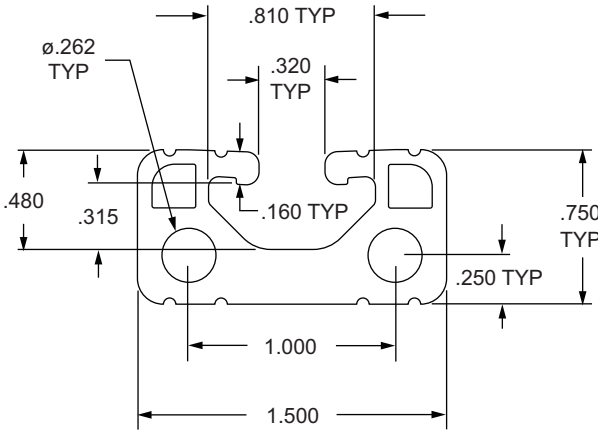

Part No.	Series	Stock Length	Material	Alloy**	Finish	Drop Lock	Moment of Inertia	Surface Area	Yield Strength	Modulus of Elasticity	Weight
1534-Lite *	15	145"	Aluminum	6105-T5	Clear Anodize	2°	IX = 0.0356 ⁱⁿ⁴ IY = 0.1360 ⁱⁿ⁴	0.634 in. ²	35,000 psi	10,200,000 lb / in. ²	0.0618 lb / in.
1534-Lite-Black-FB		per inch			Black Anodize						

* The above profiles are sold per inch or stock length.

** Or comparable

Standard Machining Services

Service No.	Series	Service Description	Reference Page
7010	15	Cut to Length	851
7050	15	Access Hole	855
7040	15	Anchor Counterbore	857
7014	15	Tap Profile End	853
7257	15	Drill Thru & Counterbore	858

3.00" X .75" Smooth Surface T-Slotted Profile - Two Adjacent Open T-Slots

3075 Profile

3075 is a 3.00" x 0.75" fractional 15 series rectangular T-slot profile with two adjacent open T-slots, two on one 3.00" face. The profile is smooth, which makes it resistant to dirt and debris buildup while also being easy to clean. The 3075 profile is compatible with 15 series fasteners. It is a thinner profile that connects easily to flat surfaces and works well as a supporting structure or spacer for mounting accessories such as handles, door tracks, rails, valves or sensors.

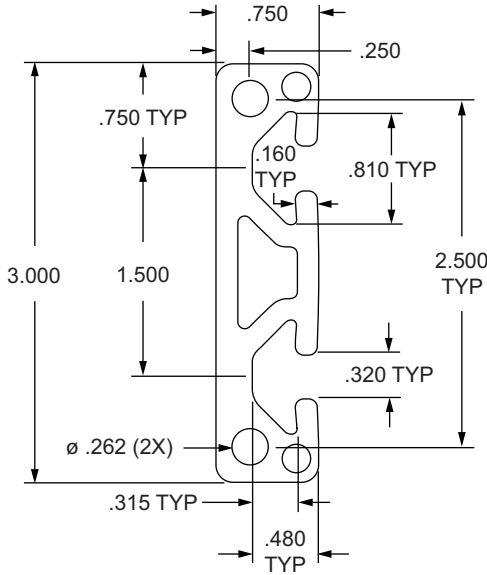

Part No.	Series	Stock Length	Material	Alloy**	Finish	Drop Lock	Moment of Inertia	Surface Area	Yield Strength	Modulus of Elasticity	Weight
3075 *	15	145"	Aluminum	6105-T5	Clear Anodize	2°	IX = 1.0672 ⁱⁿ⁴ IY = 0.0789 ⁱⁿ⁴	1.320 in. ²	35,000 psi	10,200,000 lb / in. ²	0.1287 lb / in.
3075-Black-FB		per inch			Black Anodize						

* The above profiles are sold per inch or stock length.

** Or comparable

Standard Machining Services

Service No.	Series	Service Description	Reference Page
7020	15	Cut to Length	851
7050	15	Access Hole	855
7040	15	Anchor Counterbore	857
7016	15	Tap Profile End	853
7257	15	Drill Thru & Counterbore	858

3034-Lite Profile

3034-Lite is a 3.00" x 0.75" lite fractional 15 series rectangular T-slot profile with two adjacent open T-slots, two on one 3.00" face. The profile has align-a-grooves to assist in alignment when connecting profiles. The 3034-Lite profile is compatible with 15 series fasteners. It is a thinner profile that connects easily to flat surfaces and works well as a supporting structure or spacer for mounting accessories such as handles, door tracks, rails, valves or sensors.

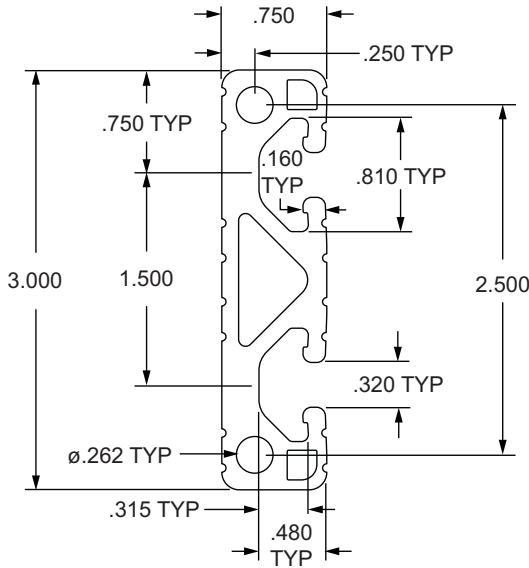

Part No.	Series	Stock Length	Material	Alloy**	Finish	Drop Lock	Moment of Inertia	Surface Area	Yield Strength	Modulus of Elasticity	Weight
3034-Lite *	15	145"	Aluminum	6105-T5	Clear Anodize	2°	IX = 0.9829 ⁱⁿ⁴ IY = 0.0725 ⁱⁿ⁴	1.186 in. ²	35,000 psi	10,200,000 lb / in. ²	0.1157 lb / in.
3034-Lite-Black-FB		per inch			Black Anodize						

* The above profiles are sold per inch or stock length.

** Or comparable

Standard Machining Services

Service No.	Series	Service Description	Reference Page
7020	15	Cut to Length	851
7050	15	Access Hole	855
7040	15	Anchor Counterbore	857
7016	15	Tap Profile End	853
7257	15	Drill Thru & Counterbore	858

1.50" X 3.00" Ultra Lite Smooth Surface T-Slotted Profile - Six Open T-Slots

1530-ULS Profile

1530-ULS is a 1.50" x 3.00" ultra-lite fractional 15 series rectangular T-slot profile with six open T-slots, two on each 3.00" face and one on each 1.50" face. The profile is smooth, which makes it resistant to dirt and debris buildup while also being easy to clean. The 1530-ULS profile is compatible with 15 series fasteners. The center cavity of the profile can be pressurized up to 150 psi, lending itself to work spaces, machine guards, displays and panel mount racks.

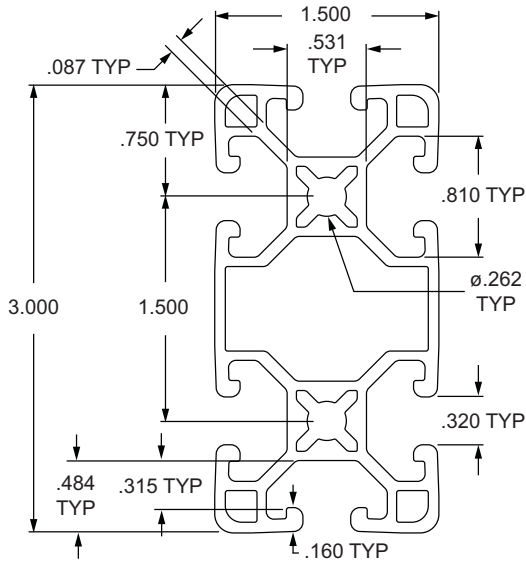

Part No.	Series	Stock Length	Material	Alloy**	Finish	Drop Lock	Moment of Inertia	Surface Area	Yield Strength	Modulus of Elasticity	Weight
1530-ULS *	15	145", 242"	Aluminum	6105-T5	Clear Anodize	2"	IX = 1.2855 ⁱⁿ⁴ IY = 0.3317 ⁱⁿ⁴	1.388 in. ²	35,000 psi	10,200,000 lb / in. ²	0.1350 lb / in.
1530-ULS-Black-FB		per inch			Black Anodize						

* The above profiles are sold per inch or stock length.

** Or comparable

Standard Machining Services

Service No.	Series	Service Description	Reference Page
7020	15	Cut to Length	851
7050	15	Access Hole	855
7040	15	Anchor Counterbore	857
7045	15	Tap Profile End	853

1530-UL Profile

1530-UL is a 1.50" x 3.00" ultra-lite fractional 15 series rectangular T-slot profile with six open T-slots, two on each 3.00" face and one on each 1.50" face. The profile has align-a-grooves to assist in alignment when connecting profiles. The 1530-UL profile is compatible with 15 series fasteners. The center cavity of the profile can be pressurized up to 150 psi, lending itself to work spaces, machine guards, displays and panel mount racks.

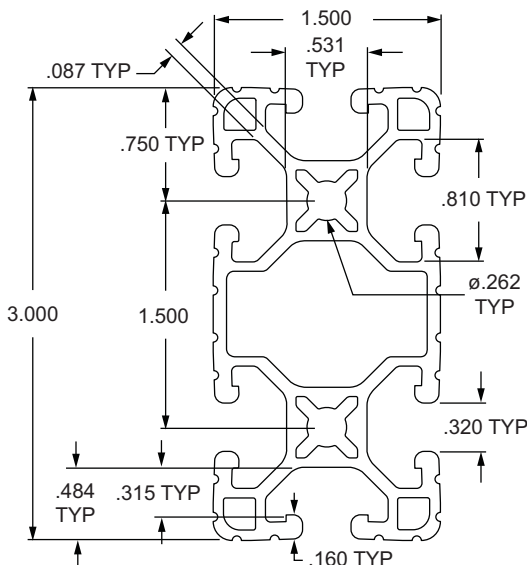

Part No.	Series	Stock Length	Material	Alloy**	Finish	Drop Lock	Moment of Inertia	Surface Area	Yield Strength	Modulus of Elasticity	Weight
1530-UL *	15	145", 242"	Aluminum	6105-T5	Clear Anodize	2°	IX = 1.2481 ^{™4} IY = 0.3177 ^{™4}	1.354 in. ²	35,000 psi	10,200,000 lb / in. ²	0.1320 lb / in.
1530-UL-Black-FB		per inch			Black Anodize						

* The above profiles are sold per inch or stock length.

** Or comparable

Standard Machining Services

Service No.	Series	Service Description	Reference Page
7020	15	Cut to Length	851
7050	15	Access Hole	855
7040	15	Anchor Counterbore	857
7045	15	Tap Profile End	853

1.50" X 3.00" Lite Smooth Surface T-Slotted Profile - Six Open T-Slots

1530-LS Profile

1530-LS is a 1.50" x 3.00" lite fractional 15 series rectangular T-slot profile with six open T-slots, two on each 3.00" face and one on each 1.50" face. The profile is smooth, which makes it resistant to dirt and debris buildup while also being easy to clean. The 1530-LS profile is compatible with 15 series fasteners. The center cavity of the profile can be pressurized up to 150 psi, lending itself to work spaces, machine guards, displays and panel mount racks.

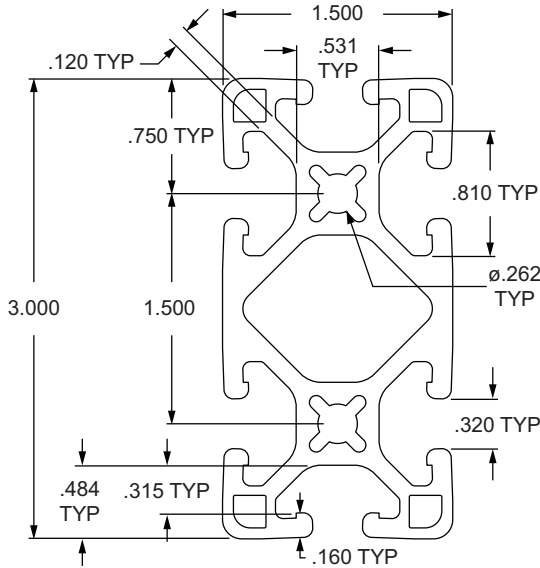

Part No.	Series	Stock Length	Material	Alloy**	Finish	Drop Lock	Moment of Inertia	Surface Area	Yield Strength	Modulus of Elasticity	Weight
1530-LS *	15	145", 242"	Aluminum	6105-T5	Clear Anodize	2°	IX = 1,3881 ¹⁴ IY = 0.4061 ¹⁴	1.682 in. ²	35,000 psi	10,200,000 lb / in. ²	0.1640 lb / in.
1530-LS-Black *		145"			Black Anodize						
1530-LS-Black-FB		per inch			Black Anodize						

* The above profiles are sold per inch or stock length.

** Or comparable

Standard Machining Services

Service No.	Series	Service Description	Reference Page
7020	15	Cut to Length	851
7050	15	Access Hole	855
7040	15	Anchor Counterbore	857
7045	15	Tap Profile End	853

1530-Lite Profile

1530-Lite is a 1.50" x 3.00" lite fractional 15 series rectangular T-slot profile with six open T-slots, two on each 3.00" face and one on each 1.50" face. The profile has align-a-grooves to assist in alignment when connecting profiles. The 1530-Lite profile is compatible with 15 series fasteners. The center cavity of the profile can be pressurized up to 150 psi, lending itself to work spaces, machine guards, displays and panel mount racks.

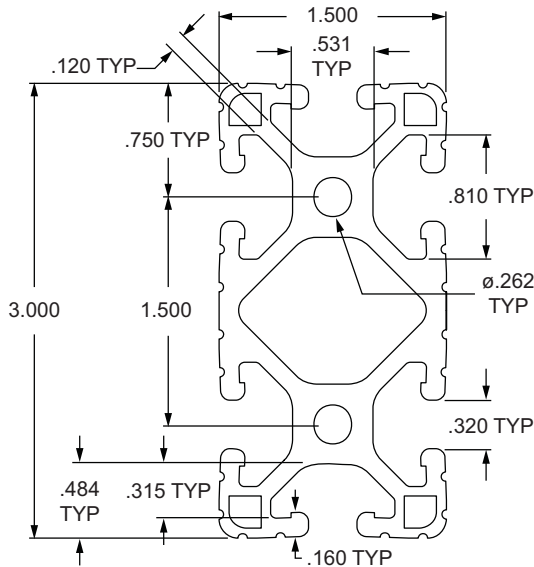

Part No.	Series	Stock Length	Material	Alloy**	Finish	Drop Lock	Moment of Inertia	Surface Area	Yield Strength	Modulus of Elasticity	Weight
1530-Lite *	15	97", 145", 242"	Aluminum	6105-T5	Clear Anodize	2°	IX = 1.3847 ^{m4} IY = 0.3935 ^{m4}	1.722 in. ²	35,000 psi	10,200,000 lb / in. ²	0.1679 lb / in.
1530-Lite-Black *		145"			Black Anodize						
1530-Lite-Black-FB		per inch			Black Anodize						
1530-Lite-Yellow *		145"			Yellow Powder Coat						

* The above profiles are sold per inch or stock length.

** Or comparable

Standard Machining Services

Service No.	Series	Service Description	Reference Page
7020	15	Cut to Length	851
7050	15	Access Hole	855
7040	15	Anchor Counterbore	857
7045	15	Tap Profile End	853

1.50" X 3.00" Smooth Surface T-Slotted Profile - Six Open T-Slots

1530-S Profile

1530-S is a 1.50" x 3.00" fractional 15 series rectangular T-slot profile with six open T-slots, two on each 3.00" face and one on each 1.50" face. The profile is smooth, which makes it resistant to dirt and debris buildup while also being easy to clean. The 1530-S profile is compatible with 15 series fasteners. The center cavity of the profile can be pressurized up to 150 psi, lending itself to work spaces, machine guards or displays.

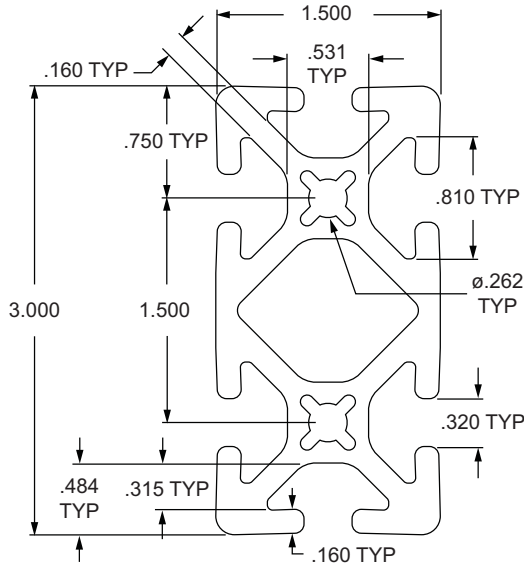

Part No.	Series	Stock Length	Material	Alloy**	Finish	Drop Lock	Moment of Inertia	Surface Area	Yield Strength	Modulus of Elasticity	Weight
1530-S *	15	145", 242"	Aluminum	6105-T5	Clear Anodize	2°	IX = 1.8127 ⁱⁿ⁴ IY = 0.4957 ⁱⁿ⁴	2.036 in. ²	35,000 psi	10,200,000 lb / in. ²	0.1985 lb / in.
1530-S-Black *		145"			Black Anodize						
1530-S-Black-FB		per inch			Black Anodize						

* The above profiles are sold per inch or stock length.

** Or comparable

Standard Machining Services

Service No.	Series	Service Description	Reference Page
7020	15	Cut to Length	851
7050	15	Access Hole	855
7040	15	Anchor Counterbore	857
7045	15	Tap Profile End	853

80/20[®] Inc. 1.50" X 3.00" T-Slotted Profile - Six Open T-Slots

1530 Profile

1530 is a 1.50" x 3.00" fractional 15 series rectangular T-slot profile with six open T-slots, two on each 3.00" face and one on each 1.50" face. The profile has align-a-grooves to assist in alignment when connecting profiles. The 1530 profile is compatible with 15 series fasteners. The center cavity of the profile can be pressurized up to 150 psi, lending itself to work spaces, machine guards, displays and panel mount racks.

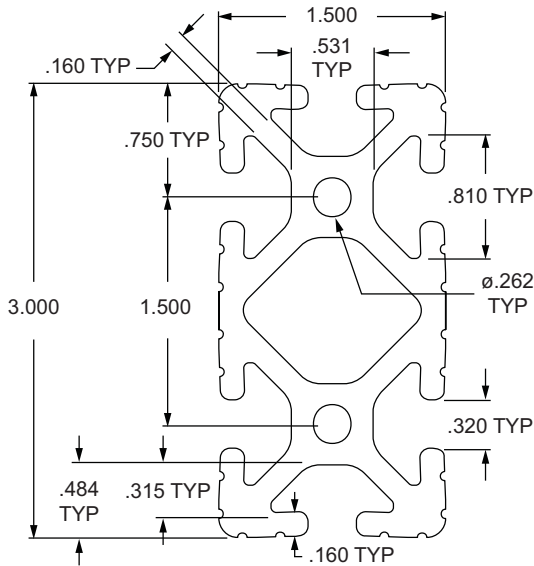

Part No.	Series	Stock Length	Material	Alloy**	Finish	Drop Lock	Moment of Inertia	Surface Area	Yield Strength	Modulus of Elasticity	Weight
1530 *	15	97", 145", 242"	Aluminum	6105-T5	Clear Anodize	2°	IX = 1.8042 ⁱⁿ⁴ IY = 0.4824 ⁱⁿ⁴	2.077 in. ²	35,000 psi	10,200,000 lb / in. ²	0.2025 lb / in.
1530-Black *		145"			Black Anodize						
1530-Black-FB		per inch			Black Anodize						

* The above profiles are sold per inch or stock length.

** Or comparable

Standard Machining Services

Service No.	Series	Service Description	Reference Page
7020	15	Cut to Length	851
7050	15	Access Hole	855
7040	15	Anchor Counterbore	857
7045	15	Tap Profile End	853

1.50" X 4.50" Smooth Surface T-Slotted Profile - Eight Open T-Slots

1545-S Profile

1545-S is a 1.50" x 4.50" fractional 15 series rectangular T-slot profile with eight open T-slots, three on each 4.50" face and one on each 1.50" face. The profile is smooth, which makes it resistant to dirt and debris buildup while also being easy to clean. The 1545-S profile is compatible with 15 series fasteners and has center cavities that can be pressurized up to 150 psi. The eight open T-slots make this profile great for mounting accessories, flat plates and hinges while the ability to pressurize it lends it to machine frames or robotics.

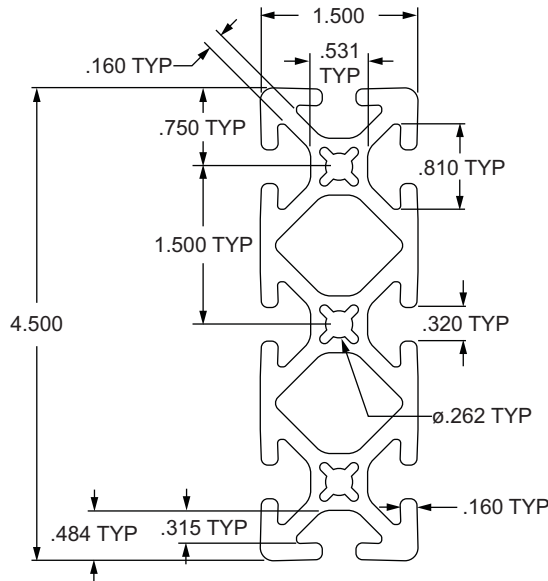

Part No.	Series	Stock Length	Material	Alloy**	Finish	Drop Lock	Moment of Inertia	Surface Area	Yield Strength	Modulus of Elasticity	Weight
1545-S*	15	145", 242"	Aluminum	6105-T5	Clear Anodize	2°	IX = 5.6675 ^{in.4} IY = 0.7282 ^{in.4}	2.935 in. ²	35,000 psi	10,200,000 lb / in. ²	0.2862 lb / in.
1545-S-Black-FB		per inch			Black Anodize						

* The above profiles are sold per inch or stock length.

** Or comparable

Standard Machining Services

Service No.	Series	Service Description	Reference Page
7021	15	Cut to Length	851
7050	15	Access Hole	855
7040	15	Anchor Counterbore	857
7026	15	Tap Profile End	853

1545 Profile

1545 is a 1.50" x 4.50" fractional 15 series rectangular T-slot profile with eight open T-slots, three on each 4.50" face and one on each 1.50" face. The profile has align-a-grooves to assist in alignment when connecting profiles. The 1545 profile is compatible with 15 series fasteners and has center cavities that can be pressurized up to 150 psi. The eight open T-slots make this profile great for mounting accessories, flat plates and hinges while the pressurized cavities lend it to machine frames or robotics.

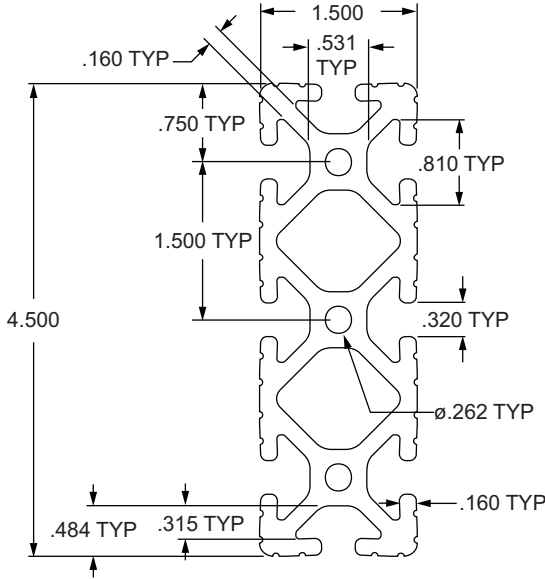

Part No.	Series	Stock Length	Material	Alloy**	Finish	Drop Lock	Moment of Inertia	Surface Area	Yield Strength	Modulus of Elasticity	Weight
1545 *	15	145", 242"	Aluminum	6105-T5	Clear Anodize	2°	IX = 5.6929 ^{™4} IY = 0.7097 ^{™4}	3.002 in. ²	35,000 psi	10,200,000 lb / in. ²	0.2927 lb / in.
1545-Black-FB		per inch			Black Anodize						

* The above profiles are sold per inch or stock length.

** Or comparable

Standard Machining Services

Service No.	Series	Service Description	Reference Page
7021	15	Cut to Length	851
7050	15	Access Hole	855
7040	15	Anchor Counterbore	857
7026	15	Tap Profile End	853

3.00" X 3.00" Lite Smooth T-Slotted Profile - Eight Open T-Slots

3030-LS Profile

3030-LS is a 3.00" x 3.00" lite fractional 15 series square T-slot profile with eight open T-slots, two on each 3.00" face. The profile is smooth, which makes it resistant to dirt and debris buildup while also being easy to clean. The 3030-LS profile is the light-duty version in the 3030 profile family, is compatible with 15 series fasteners, and has a center cavity that can be pressurized up to 150 psi. The eight open T-slots, strength, and ability to pressurize this profile make it a great choice for automation applications, machine frames and workstations.

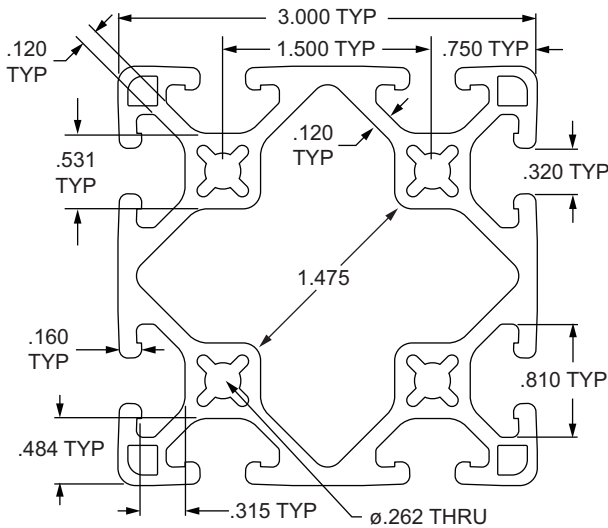

Part No.	Series	Stock Length	Material	Alloy**	Finish	Drop Lock	Moment of Inertia	Surface Area	Yield Strength	Modulus of Elasticity	Weight
3030-LS *	15	145", 242"	Aluminum	6105-T5	Clear Anodize	2"	IX = 2.6861 ¹⁴ IY = 2.6861 ¹⁴	2.659 in. ²	35,000 psi	10,200,000 lb / in. ²	0.2593 lb / in.
3030-LS-Black-FB		per inch			Black Anodize						

* The above profiles are sold per inch or stock length.

** Or comparable

Standard Machining Services

Service No.	Series	Service Description	Reference Page
7030	15	Cut to Length	851
7050	15	Access Hole	855
7040	15	Anchor Counterbore	857
7055	15	Tap Profile End	853

3030-Lite Profile

3030-Lite is a 3.00" x 3.00" lite fractional 15 series square T-slot profile with eight open T-slots, two on each 3.00" face. The profile has align-a-grooves to assist in alignment when connecting profiles. The 3030-Lite profile is the light-duty version in the 3030 profile family, is compatible with 15 series fasteners, and has a center cavity that can be pressurized up to 150 psi. The eight open T-slots, strength, and ability to pressurize this profile make it a great choice for automation applications, machine frames and workstations.

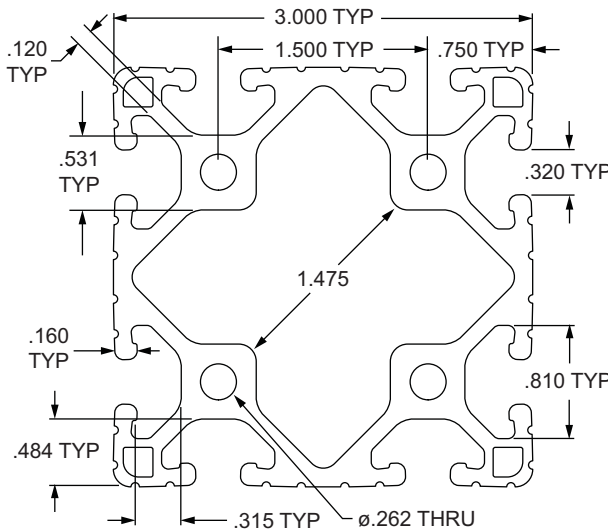

Part No.	Series	Stock Length	Material	Alloy**	Finish	Drop Lock	Moment of Inertia	Surface Area	Yield Strength	Modulus of Elasticity	Weight
3030-Lite *	15	145", 242"	Aluminum	6105-T5	Clear Anodize	2°	IX = 2.6959 ⁱⁿ⁴ IY = 2.6959 ⁱⁿ⁴	2.763 in. ²	35,000 psi	10,200,000 lb / in. ²	0.2695 lb / in.
3030-Lite-Black-FB		per inch			Black Anodize						

* The above profiles are sold per inch or stock length.

** Or comparable

Standard Machining Services

Service No.	Series	Service Description	Reference Page
7030	15	Cut to Length	851
7050	15	Access Hole	855
7040	15	Anchor Counterbore	857
7055	15	Tap Profile End	853

3.00" X 3.00" Smooth Surface T-Slotted Profile - Eight Open T-Slots

3030-S Profile

3030-S is a 3.00" x 3.00" fractional 15 series square T-slot profile with eight open T-slots, two on each 3.00" face. The profile is smooth, which makes it resistant to dirt and debris buildup. The 3030-S profile is compatible with 15 series fasteners and has a center cavity that can be pressurized up to 150 psi. The eight open T-slots, strength, and ability to pressurize this profile make it a great choice for automation applications, machine frames and workstations.

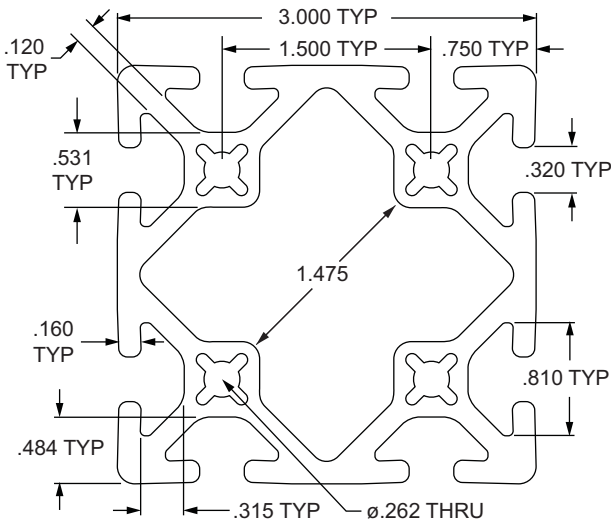

Part No.	Series	Stock Length	Material	Alloy**	Finish	Drop Lock	Moment of Inertia	Surface Area	Yield Strength	Modulus of Elasticity	Weight
3030-S *	15	145", 242"	Aluminum	6105-T5	Clear Anodize	2°	IX = 3.3496 ⁱⁿ⁴ IY = 3.3496 ⁱⁿ⁴	3.109 in. ²	35,000 psi	10,200,000 lb / in. ²	0.3032 lb / in.
3030-S-Black *		145"			Black Anodize						
3030-S-Black-FB		per inch			Black Anodize						

* The above profiles are sold per inch or stock length.

** Or comparable

Standard Machining Services

Service No.	Series	Service Description	Reference Page
7030	15	Cut to Length	851
7050	15	Access Hole	855
7040	15	Anchor Counterbore	857
7055	15	Tap Profile End	853

3030 Profile

3030 is a 3.00" x 3.00" fractional 15 series square T-slot profile with eight open T-slots, two on each 3.00" face. The profile has align-a-grooves to assist in alignment when connecting profiles. The 3030 profile is compatible with 15 series fasteners and has a center cavity that can be pressurized up to 150 psi. The eight open T-slots, strength, and ability to pressurize this profile make it a great choice for automation applications, machine frames and workstations.

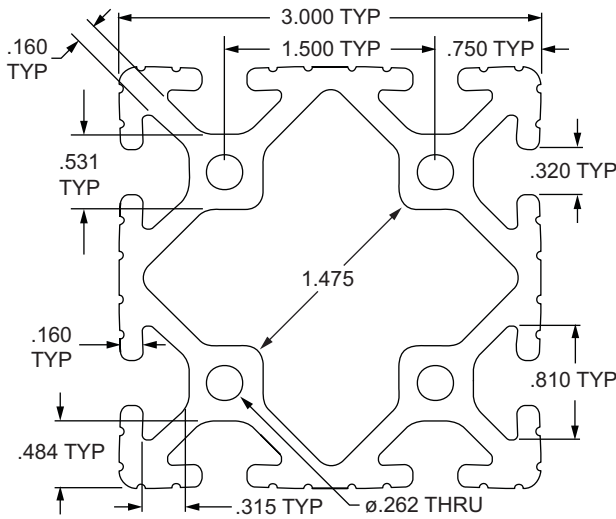

Part No.	Series	Stock Length	Material	Alloy**	Finish	Drop Lock	Moment of Inertia	Surface Area	Yield Strength	Modulus of Elasticity	Weight
3030 *	15	145", 242"	Aluminum	6105-T5	Clear Anodize	2°	IX = 3.4133 ⁱⁿ⁴ IY = 3.4133 ⁱⁿ⁴	3.212 in. ²	35,000 psi	10,200,000 lb / in. ²	0.3132 lb / in.
3030-Black *		145"			Black Anodize						
3030-Black-FB		per inch			Black Anodize						

* The above profiles are sold per inch or stock length.

** Or comparable

Standard Machining Services

Service No.	Series	Service Description	Reference Page
7030	15	Cut to Length	851
7050	15	Access Hole	855
7040	15	Anchor Counterbore	857
7055	15	Tap Profile End	853

3.00" X 6.00" T-Slotted Profile - Twelve Open T-Slots

3060 Profile

3060 is a 3.00" x 6.00" fractional 15 series rectangular T-slot profile with twelve open T-slots, two on each 3.00" face and four on each 6.00" face. The profile has align-a-grooves to assist in alignment when connecting profiles. The 3060 profile is the largest fractional profile offered by 80/20, is compatible with 15 series fasteners, and has center cavities that can be pressurized up to 150 psi. The twelve open T-slots, strength, and ability to pressurize this profile make it a great choice for automation, machine framing and workstations.

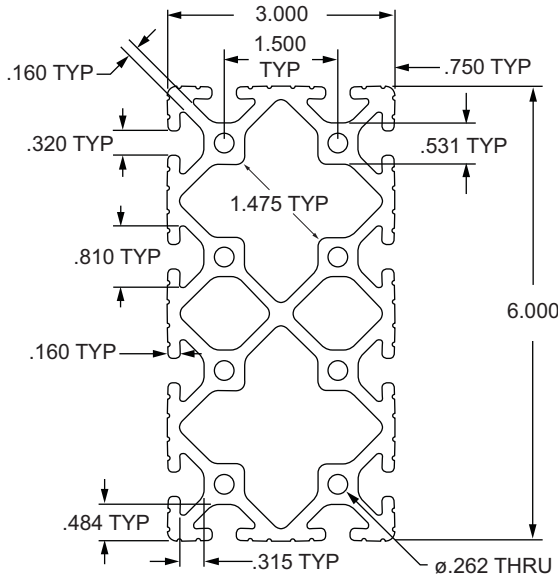

Part No.	Series	Stock Length	Material	Alloy**	Finish	Drop Lock	Moment of Inertia	Surface Area	Yield Strength	Modulus of Elasticity	Weight
3060 *	15	145", 242"	Aluminum	6105-T5	Clear Anodize	2°	IX = 22.0300 ⁷⁴ IY = 6.5164 ⁷⁴	5.963 in. ²	35,000 psi	10,200,000 lb / in. ²	0.5815 lb / in.
3060-Black-FB		per inch			Black Anodize						

* The above profiles are sold per inch or stock length.

** Or comparable

Standard Machining Services

Service No.	Series	Service Description	Reference Page
7023	15	Cut to Length	851
7050	15	Access Hole	855
7040	15	Anchor Counterbore	857
7029	15	Tap Profile End	853

20-2020 Profile

20-2020 is a 20mm x 20mm metric 20 series square T-slot profile with four open T-slots, one on each 20mm face. The profile is smooth, which makes it resistant to dirt and debris buildup while also being easy to clean. The 20-2020 profile is compatible with all 20 series fasteners. The 20-2020 profile is part of the smallest profile series 80/20 offers and lends itself to machine guards, work benches, panel mount racks or displays. The four open T-slots enable access from any direction and are useful for mounting accessories.

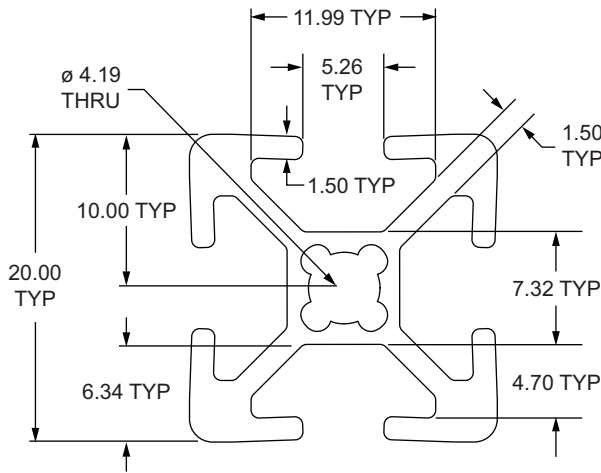

Part No.	Series	Stock Length	Material	Alloy**	Finish	Drop Lock	Moment of Inertia	Surface Area	Yield Strength	Modulus of Elasticity	Weight
20-2020 *	20	4 or 6 Meter	Aluminum	6105-T5	Clear Anodize	2°	IX = 0.6826 cm ⁴ IY = 0.6826 cm ⁴	1.591 cm ²	241.1 N / mm ²	70,326.5 N / mm ²	0.4420 kg / m
20-2020-Black-FB		per millimeter			Black Anodize						

* The above profiles are sold per millimeter or stock length.

** Or comparable

Standard Machining Services

Service No.	Series	Service Description	Reference Page
20-7005	20	Cut to Length	851
20-7069	20	Access Hole	855
20-7042	20	Anchor Counterbore	857
20-7063	20	Tap Profile End	853

20mm X 40mm T-Slotted Profile - Six Open T-Slots

20-2040 Profile

20-2040 is a 20mm x 40mm metric 20 series rectangular T-slot profile with six open T-slots, two on each 40mm face and one on each 20mm face. The profile is smooth, which makes it resistant to dirt and debris buildup while also being easy to clean. The 20-2040 profile is compatible with 20 series fasteners. It is a part of the smallest profile series 80/20 offers, lending itself to work spaces, machine guards, displays and panel mount racks.

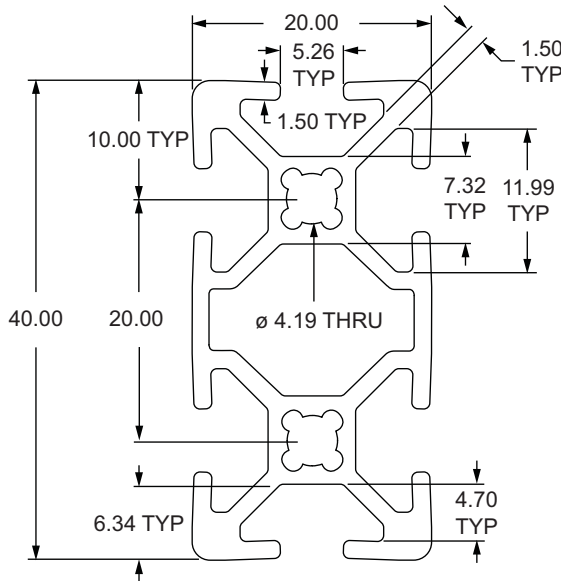

Part No.	Series	Stock Length	Material	Alloy**	Finish	Drop Lock	Moment of Inertia	Surface Area	Yield Strength	Modulus of Elasticity	Weight
20-2040 *	20	4 or 6 Meter	Aluminum	6105-T5	Clear Anodize	2°	IX = 4.5357 cm ⁴ IY = 1.2133 cm ⁴	2.750 cm ²	241.1 N / mm ²	70,326.5 N / mm ²	0.7426 kg / m
20-2040-Black-FB		per millimeter			Black Anodize						

* The above profiles are sold per millimeter or stock length.

** Or comparable

Standard Machining Services

Service No.	Series	Service Description	Reference Page
20-7020	20	Cut to Length	851
20-7069	20	Access Hole	855
20-7042	20	Anchor Counterbore	857
20-7047	20	Tap Profile End	854

20-4040 Profile

20-4040 is a 40mm x 40mm metric 20 series square T-slot profile with eight open T-slots, two on each 40mm face. The profile is smooth, which makes it resistant to dirt and debris buildup while also being easy to clean. The 20-4040 profile is compatible with 20 series fasteners. The eight open T-slots and strength make it a great choice for automation applications, machine frames and workstations.

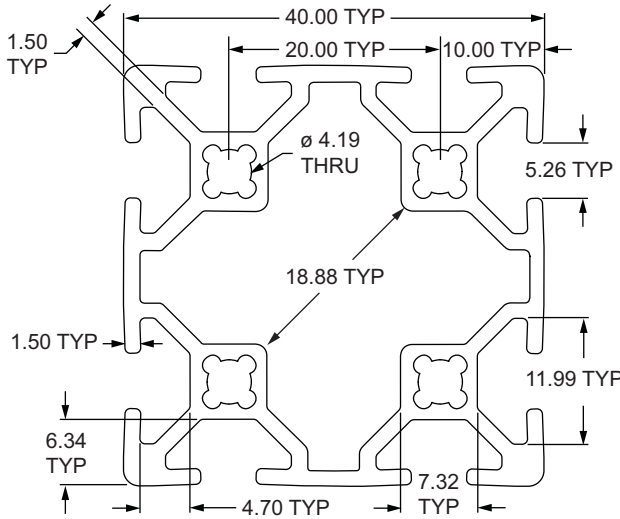

Part No.	Series	Stock Length	Material	Alloy**	Finish	Drop Lock	Moment of Inertia	Surface Area	Yield Strength	Modulus of Elasticity	Weight
20-4040 *	20	4 or 6 Meter	Aluminum	6105-T5	Clear Anodize	2°	IX = 7.8219 cm ⁴ IY = 7.8219 cm ⁴	4.227 cm ²	241.1 N / mm ²	70,326.5 N / mm ²	1.1721 kg / m
20-4040-Black-FB		per millimeter			Black Anodize						

* The above profiles are sold per millimeter or stock length.

** Or comparable

Standard Machining Services

Service No.	Series	Service Description	Reference Page
20-7030	20	Cut to Length	851
20-7069	20	Access Hole	855
20-7042	20	Anchor Counterbore	857
20-7067	20	Tap Profile End	854

25mm X 25mm T-Slotted Profile - Four Open T-Slots

25-2525 Profile

25-2525 is a 25mm x 25mm metric 25 series square T-slot profile with four open T-slots, one on each 25mm face. The profile is smooth, which makes it resistant to dirt and debris buildup while also being easy to clean. The 25-2525 profile is compatible with all 25 series fasteners. This profile lends itself to clean room applications, guards, enclosures, or workstations.

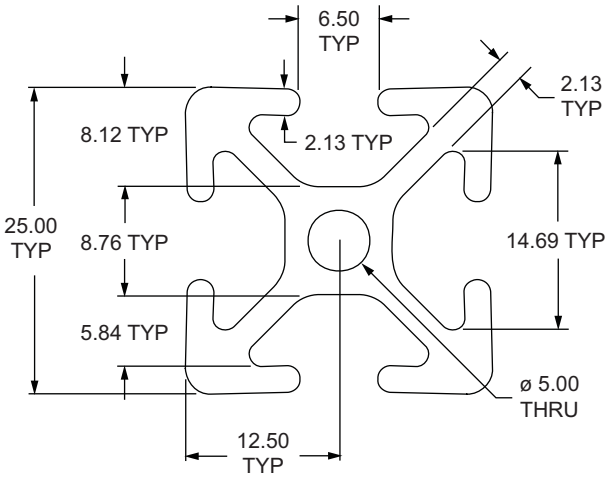

Part No.	Series	Stock Length	Material	Alloy**	Finish	Drop Lock	Moment of Inertia	Surface Area	Yield Strength	Modulus of Elasticity	Weight
25-2525 *	25	4 or 6 Meter	Aluminum	6105-T5	Clear Anodize	2°	IX = 1.7726 cm ⁴ IY = 1.7726 cm ⁴	2.746 cm ²	241.1 N / mm ²	70,326.5 N / mm ²	0.7426 kg / m
25-2525-Black *		4 Meter			Black Anodize						
25-2525-Black-FB		per millimeter			Black Anodize						

* The above profiles are sold per millimeter or stock length.

** Or comparable

Standard Machining Services

Service No.	Series	Service Description	Reference Page
25-7005	25	Cut to Length	851
25-7051	25	Access Hole	855
25-7042	25	Anchor Counterbore	857
25-7063	25	Tap Profile End	854

25-2501 Profile

25-2501 is a 25mm x 25mm metric 25 series square T-slot profile with one open T-slot on one 25mm face. The profile is smooth, which makes it resistant to dirt and debris buildup while also being easy to clean. The 25-2501 profile is compatible with 25 series fasteners. The three closed faces on this profile provide a clean, aesthetic look and it lends itself to furniture, displays, desks, trade show booths, or retail kiosks.

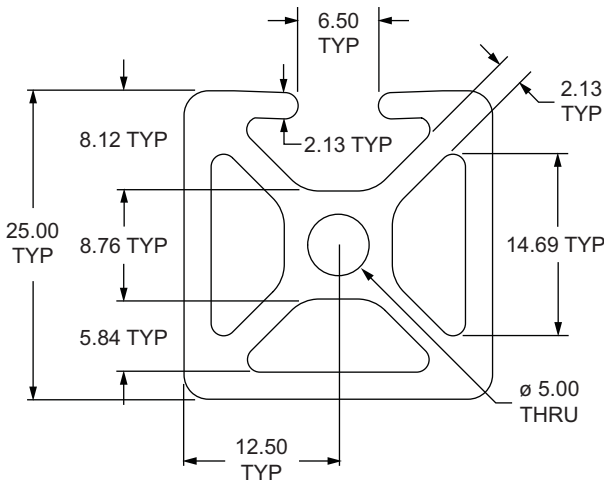

Part No.	Series	Stock Length	Material	Alloy**	Finish	Drop Lock	Moment of Inertia	Surface Area	Yield Strength	Modulus of Elasticity	Weight
25-2501 *	25	4 or 6 Meter	Aluminum	6105-T5	Clear Anodize	2°	IX = 2.1892 cm ⁴ IY = 1.9873 cm ⁴	3.185 cm ²	241.1 N / mm ²	70,326.5 N / mm ²	0.8607 kg / m
25-2501-Black-FB		per millimeter			Black Anodize						

* The above profiles are sold per millimeter or stock length.

** Or comparable

Standard Machining Services

Service No.	Series	Service Description	Reference Page
25-7005	25	Cut to Length	851
25-7051	25	Access Hole	855
25-7042	25	Anchor Counterbore	857
25-7063	25	Tap Profile End	854

25mm X 25mm T-Slotted Profile - Two Adjacent Open T-Slots

25-2502 Profile

25-2502 is a 25mm x 25mm metric 25 series square T-slot profile with two adjacent open T-slots, one on two 25mm faces. The profile is smooth, which makes it resistant to dirt and debris buildup while also being easy to clean. The 25-2502 profile is compatible with 25 series fasteners. The two closed faces on this profile provide a clean, aesthetic look while also having the capability to mount additional profiles, parts and accessories. It lends itself to furniture, displays, desks, trade show booths, or retail kiosks.

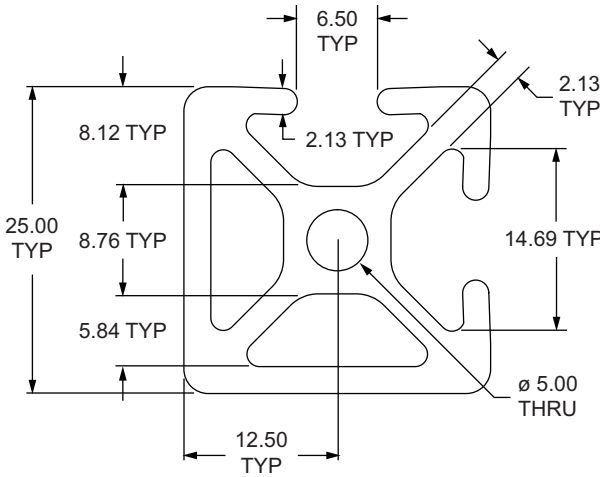

Part No.	Series	Stock Length	Material	Alloy**	Finish	Drop Lock	Moment of Inertia	Surface Area	Yield Strength	Modulus of Elasticity	Weight
25-2502 *	25	4 or 6 Meter	Aluminum	6105-T5	Clear Anodize	2°	IX = 1.9780 cm ⁴ IY = 1.9780 cm ⁴	3.039 cm ²	241.1 N / mm ²	70,326.5 N / mm ²	0.8214 kg / m
25-2502-Black-FB		per millimeter			Black Anodize						

* The above profiles are sold per millimeter or stock length.

** Or comparable

Standard Machining Services

Service No.	Series	Service Description	Reference Page
25-7005	25	Cut to Length	851
25-7051	25	Access Hole	855
25-7042	25	Anchor Counterbore	857
25-7063	25	Tap Profile End	854

25-2503 Profile

25-2503 is a 25mm x 25mm metric 25 series square T-slot profile with three adjacent open T-slots, one on three 25mm faces. The profile is smooth, which makes it resistant to dirt and debris buildup while also being easy to clean. The 25-2503 profile is compatible with 25 series fasteners. The closed face on this profile provides a clean, aesthetic look while also having the capability to mount additional profiles, parts, and accessories.

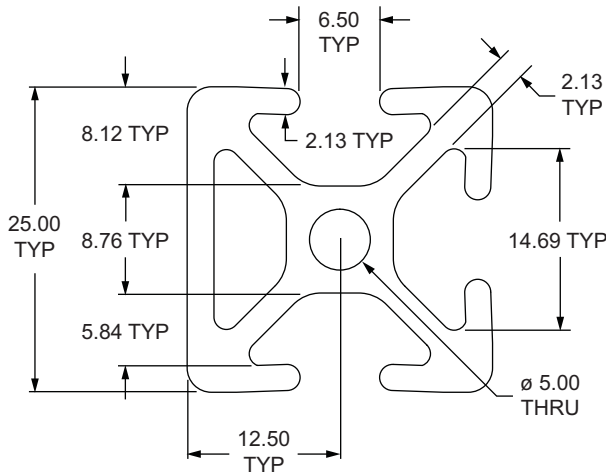

Part No.	Series	Stock Length	Material	Alloy**	Finish	Drop Lock	Moment of Inertia	Surface Area	Yield Strength	Modulus of Elasticity	Weight
25-2503 *	25	4 or 6 Meter	Aluminum	6105-T5	Clear Anodize	2°	IX = 1.9688 cm ⁴ IY = 1.7669 cm ⁴	2.892 cm ²	241.1 N / mm ²	70,326.5 N / mm ²	0.7820 kg / m
25-2503-Black-FB		per millimeter			Black Anodize						

* The above profiles are sold per millimeter or stock length.

** Or comparable

Standard Machining Services

Service No.	Series	Service Description	Reference Page
25-7005	25	Cut to Length	851
25-7051	25	Access Hole	855
25-7042	25	Anchor Counterbore	857
25-7063	25	Tap Profile End	854

25mm X 25mm T-Slotted Profile - Two Opposite Open T-Slots

25-2504 Profile

25-2504 is a 25mm x 25mm metric 25 series square T-slot profile with two opposite open T-slots, one on two 25mm faces. The profile is smooth, which makes it resistant to dirt and debris buildup while also being easy to clean. The 25-2504 profile is compatible with 25 series fasteners. The placement of the T-slots allow support structures or panels to be easily placed into them while maintaining a continuous surface, lending itself to projects such as guarding, furniture or displays.

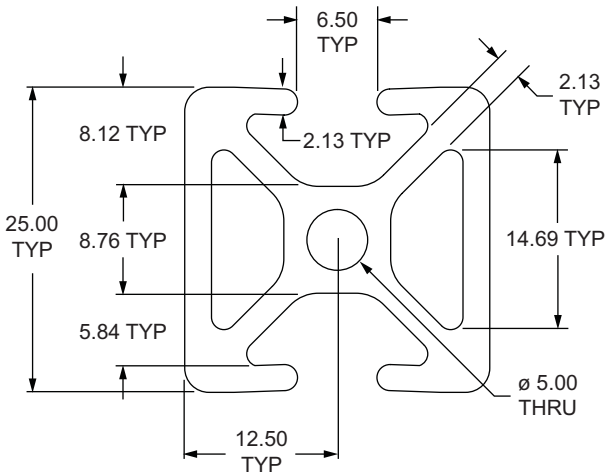

Part No.	Series	Stock Length	Material	Alloy**	Finish	Drop Lock	Moment of Inertia	Surface Area	Yield Strength	Modulus of Elasticity	Weight
25-2504 *	25	4 or 6 Meter	Aluminum	6105-T5	Clear Anodize	2°	IX = 2.2730 cm ⁴ IY = 1.7761 cm ⁴	3.039 cm ²	241.1 N / mm ²	70,326.5 N / mm ²	0.8214 kg / m
25-2504-Black-FB		per millimeter			Black Anodize						

* The above profiles are sold per millimeter or stock length.

** Or comparable

Standard Machining Services

Service No.	Series	Service Description	Reference Page
25-7005	25	Cut to Length	851
25-7051	25	Access Hole	855
25-7042	25	Anchor Counterbore	857
25-7063	25	Tap Profile End	854

80/20® 25mm X 25mm Quarter Round T-Slotted Profile - Two Open T-Slots

25-2527 Profile

25-2527 is a 25mm x 25mm metric 25 series quarter round T-slot profile with an 18.75mm radius curved back and two open T-slots, one on each of the 25mm profile faces. The profile is smooth, which makes it resistant to dirt and debris buildup while also being easy to clean. The 25-2527 profile is compatible with 25 series fasteners. This profile lends itself to workstations and displays because panels or other support structures can be easily placed in the T-slots allowing a continuous surface and aesthetic appearance.

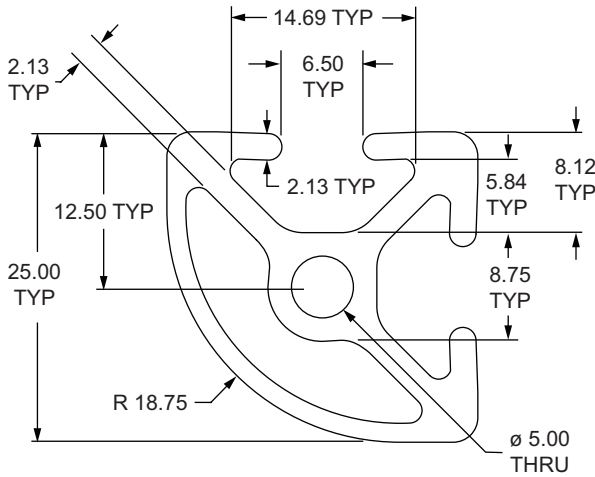

Part No.	Series	Stock Length	Material	Alloy**	Finish	Drop Lock	Moment of Inertia	Surface Area	Yield Strength	Modulus of Elasticity	Weight
25-2527 *	25	4 or 6 Meter	Aluminum	6105-T5	Clear Anodize	2°	IX = 1.4578 cm ⁴ IY = 1.4578 cm ⁴	2.428 cm ²	241.1 N / mm ²	70,326.5 N / mm ²	0.6567 kg / m
25-2527-Black-FB		per millimeter			Black Anodize						

* The above profiles are sold per millimeter or stock length.

** Or comparable

Standard Machining Services

Service No.	Series	Service Description	Reference Page
25-7005	25	Cut to Length	851
25-7051	25	Access Hole	855
25-7042	25	Anchor Counterbore	857
25-7063	25	Tap Profile End	854

25mm X 12.5mm T-Slotted Profile - Single Open T-slot

25-2514 Profile

25-2514 is a 25mm x 12.5mm metric 25 series rectangular T-slot profile with one open T-slot on one 25mm face. The profile is smooth, which makes it resistant to dirt and debris buildup while also being easy to clean. The 25-2514 profile is compatible with 25 series fasteners. It is a thinner profile that connects easily to flat surfaces and works well as a supporting structure or spacer for mounting accessories such as handles, door tracks, rails, valves or sensors.

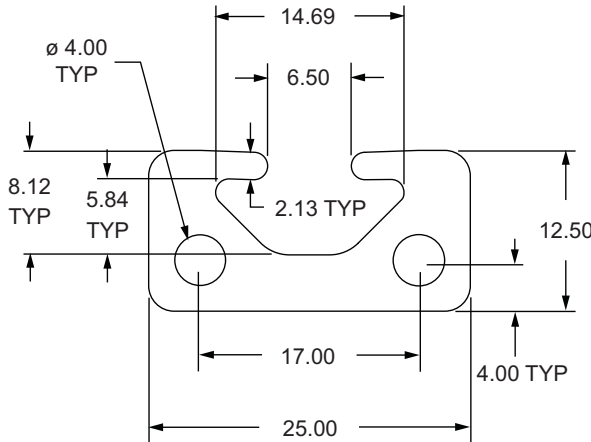

Part No.	Series	Stock Length	Material	Alloy**	Finish	Drop Lock	Moment of Inertia	Surface Area	Yield Strength	Modulus of Elasticity	Weight
25-2514 *	25	4 Meter	Aluminum	6105-T5	Clear Anodize	2°	IX = 0.3030 cm ⁴ IY = 1.3003 cm ⁴	2.022 cm ²	241.1 N / mm ²	70,326.5 N / mm ²	0.5458 kg / m
25-2514-Black-FB		per millimeter			Black Anodize						

* The above profiles are sold per millimeter or stock length.

** Or comparable

Standard Machining Services

Service No.	Series	Service Description	Reference Page
25-7005	25	Cut to Length	851
25-7051	25	Access Hole	855
25-7042	25	Anchor Counterbore	857
25-7007	25	Tap Profile End	854
25-7256	25	Drill Thru & Counterbore	858

80/20[®] 50mm X 12.5mm T-Slotted Profile - Two Adjacent Open T-Slots

25-5013 Profile

25-5013 is a 50mm x 12.5mm metric 25 series rectangular T-slot profile with two adjacent open T-slots, two on one 50mm face. The profile is smooth, which makes it resistant to dirt and debris buildup while also being easy to clean. The 25-5013 profile is compatible with 25 series fasteners. It is a thinner profile that connects easily to flat surfaces and works well as a supporting structure or spacer for mounting accessories such as handles, door tracks, rails, valves or sensors.

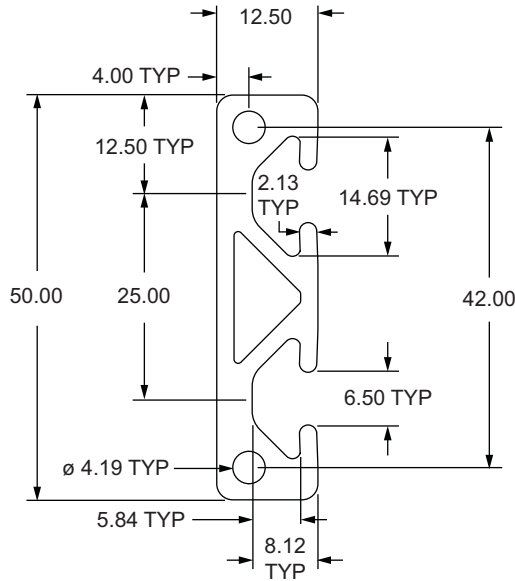

Part No.	Series	Stock Length	Material	Alloy**	Finish	Drop Lock	Moment of Inertia	Surface Area	Yield Strength	Modulus of Elasticity	Weight
25-5013 *	25	4 Meter	Aluminum	6105-T5	Clear Anodize	2°	IX = 8.8452 cm ⁴ IY = 0.5897 cm ⁴	3.528 cm ²	241.1 N / mm ²	70,326.5 N / mm ²	0.9627 kg / m
25-5013-Black-FB		per millimeter			Black Anodize						

* The above profiles are sold per millimeter or stock length.

** Or comparable

Standard Machining Services

Service No.	Series	Service Description	Reference Page
25-7005	25	Cut to Length	851
25-7051	25	Access Hole	855
25-7042	25	Anchor Counterbore	857
25-7009	25	Tap Profile End	854
25-7256	25	Drill Thru & Counterbore	858

25mm X 50mm T-Slotted Profile - Six Open T-Slots

25-2550 Profile

25-2550 is a 25mm x 50mm metric 25 series rectangular T-slot profile with six open T-slots, two on each 50mm face and one on each 25mm face. The profile is smooth, which makes it resistant to dirt and debris buildup while also being easy to clean. The 25-2550 profile is compatible with 25 series fasteners. The center cavity of the profile can be pressurized up to 1.034 N/mm² (150 psi), lending itself to work spaces, machine guards, displays and panel mount racks.

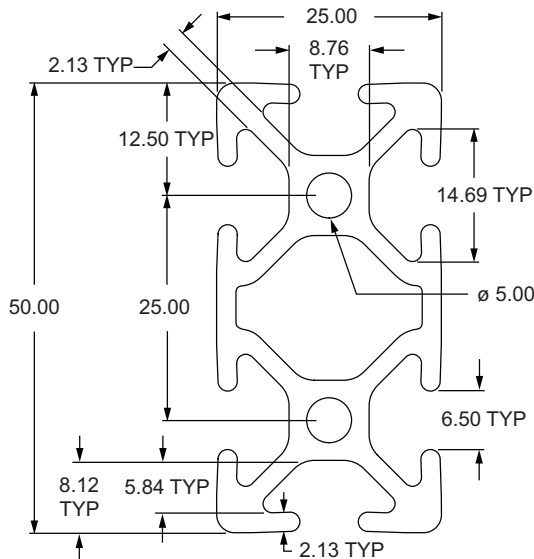

Part No.	Series	Stock Length	Material	Alloy**	Finish	Drop Lock	Moment of Inertia	Surface Area	Yield Strength	Modulus of Elasticity	Weight
25-2550 *	25	4 or 6 Meter	Aluminum	6105-T5	Clear Anodize	2°	IX = 12.1714 cm ⁴ IY = 3.1966 cm ⁴	4.857 cm ²	241.1 N / mm ²	70,326.5 N / mm ²	1.3135 kg / m
25-2550-Black *		4 Meter			Black Anodize						
25-2550-Black-FB		per millimeter			Black Anodize						

* The above profiles are sold per millimeter or stock length.

** Or comparable

Standard Machining Services

Service No.	Series	Service Description	Reference Page
25-7000	25	Cut to Length	851
25-7051	25	Access Hole	855
25-7042	25	Anchor Counterbore	857
25-7047	25	Tap Profile End	854

25-2576 Profile

25-2576 is a 25mm x 75mm metric 25 series rectangular T-slot profile with eight open T-slots, three on each 75mm face and one on each 25mm face. The profile is smooth, which makes it resistant to dirt and debris while also easy to clean. The 25-2576 profile is compatible with 25 series fasteners and has center cavities that can be pressurized up to 1.034 N/mm² (150 psi). The eight open T-slots make this profile great for mounting accessories, flat plates and hinges while the ability to pressurize it lends it to projects with linear motion or machine frames.

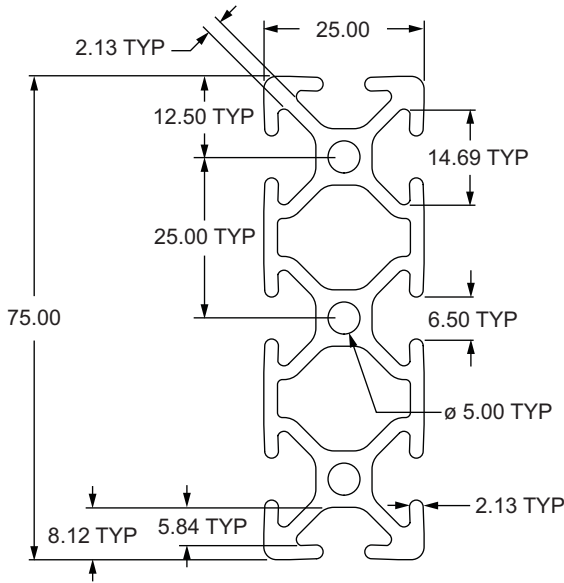

Part No.	Series	Stock Length	Material	Alloy**	Finish	Drop Lock	Moment of Inertia	Surface Area	Yield Strength	Modulus of Elasticity	Weight
25-2576 *	25	4 or 6 Meter	Aluminum	6105-T5	Clear Anodize	2°	IX = 37.2852 cm ⁴ IY = 4.5921 cm ⁴	6.889 cm ²	241.1 N / mm ²	70,326.5 N / mm ²	1.8664 kg / m
25-2576-Black-FB		per millimeter			Black Anodize						

* The above profiles are sold per millimeter or stock length.

** Or comparable

Standard Machining Services

Service No.	Series	Service Description	Reference Page
25-7003	25	Cut to Length	851
25-7051	25	Access Hole	855
25-7042	25	Anchor Counterbore	857
25-7037	25	Tap Profile End	854

50mm X 50mm T-Slotted Profile - Eight Open T-Slots

25-5050 Profile

25-5050 is a 50mm x 50mm metric 25 series square T-slot profile with eight open T-slots, two on each 50mm face. The profile is smooth, which makes it resistant to dirt and debris buildup while also being easy to clean. The 25-5050 profile is compatible with 25 series fasteners and has a center cavity that can be pressurized up to 1.034 N/mm² (150 psi). The eight open T-slots, strength, and ability to pressurize this profile make it a great choice for automation applications, machine frames and workstations.

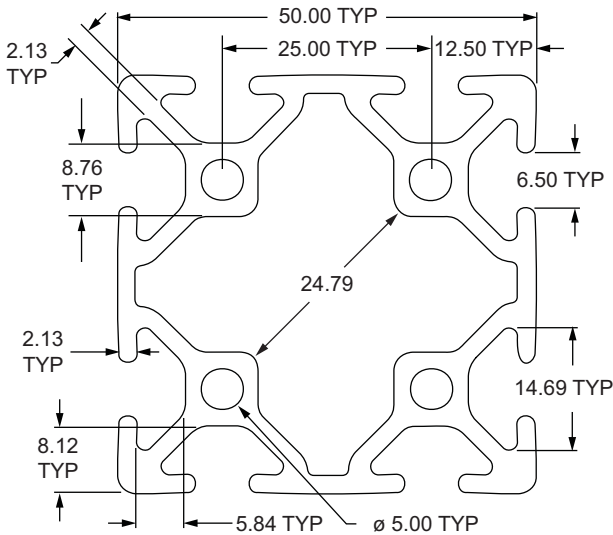

Part No.	Series	Stock Length	Material	Alloy**	Finish	Drop Lock	Moment of Inertia	Surface Area	Yield Strength	Modulus of Elasticity	Weight
25-5050 *	25	4 or 6 Meter	Aluminum	6105-T5	Clear Anodize	2°	IX = 21.1231 cm ⁴ IY = 21.1231 cm ⁴	7.487 cm ²	241.1 N / mm ²	70,326.5 N / mm ²	2.0239 kg / m
25-5050-Black *		4 Meter			Black Anodize						
25-5050-Black-FB		per millimeter			Black Anodize						

* The above profiles are sold per millimeter or stock length.

** Or comparable

Standard Machining Services

Service No.	Series	Service Description	Reference Page
25-7012	25	Cut to Length	851
25-7051	25	Access Hole	855
25-7042	25	Anchor Counterbore	857
25-7067	25	Tap Profile End	854

25-5010 Profile

25-5010 is a 50mm x 100mm metric 25 series rectangular T-slot profile with twelve open T-slots, two on each 50mm face and four on each 100mm face. The profile is smooth, which makes it resistant to dirt and debris buildup while also being easy to clean. The 25-5010 profile is compatible with 25 series fasteners, and has center cavities that can be pressurized up to 1.034 N/mm² (150 psi). The twelve open T-slots, strength, and ability to pressurize this profile make it a great choice for automation applications, machine frames and workstations.

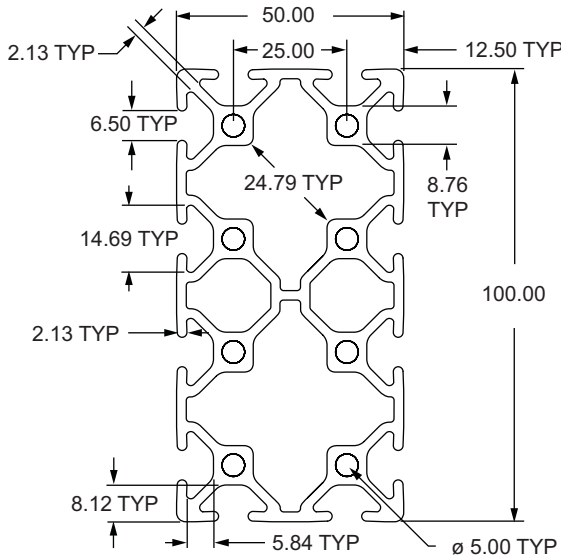

Part No.	Series	Stock Length	Material	Alloy**	Finish	Drop Lock	Moment of Inertia	Surface Area	Yield Strength	Modulus of Elasticity	Weight
25-5010 *	25	4 or 6 Meter	Aluminum	6105-T5	Clear Anodize	2°	IX = 132.0109 cm ⁴ IY = 39.1136 cm ⁴	13.743 cm ²	241.1 N / mm ²	70,326.5 N / mm ²	3.7133 kg / m
25-5010-Black-FB		per millimeter			Black Anodize						

* The above profiles are sold per millimeter or stock length.

** Or comparable

Standard Machining Services

Service No.	Series	Service Description	Reference Page
25-7013	25	Cut to Length	851
25-7051	25	Access Hole	855
25-7042	25	Anchor Counterbore	857
25-7039	25	Tap Profile End	854

30mm X 30mm T-Slotted Profile - Four Open T-Slots

30-3030 Profile

30-3030 is a 30mm x 30mm metric 30 series square T-slot profile with four open T-slots, one on each 30mm face. The profile is smooth, which makes it resistant to dirt and debris buildup while also being easy to clean. The 30-3030 profile is compatible with all 30 series fasteners. This profile lends itself to clean room applications, guards, enclosures, or workstations.

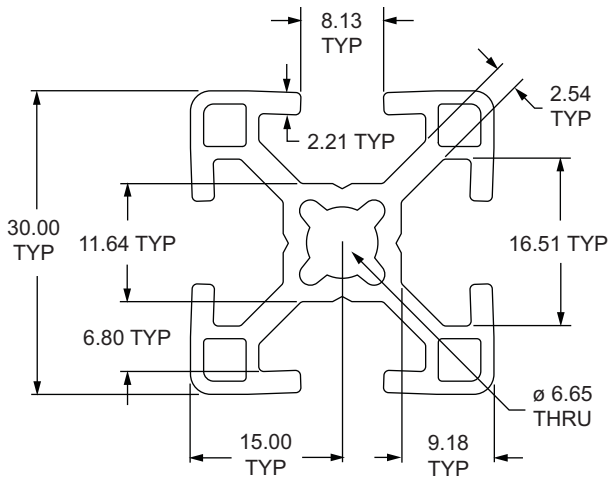

Part No.	Series	Stock Length	Material	Alloy**	Finish	Drop Lock	Moment of Inertia	Surface Area	Yield Strength	Modulus of Elasticity	Weight
30-3030 *	30	4 or 6 Meter	Aluminum	6105-T5	Clear Anodize	2°	IX = 2.7221 cm ⁴ IY = 2.7221 cm ⁴	3.144 cm ²	241.1 N / mm ²	70,326.5 N / mm ²	0.8715 kg / m
30-3030-Black-FB		per millimeter			Black Anodize						

* The above profiles are sold per millimeter or stock length.

** Or comparable

Standard Machining Services

Service No.	Series	Service Description	Reference Page
30-7010	30	Cut to Length	851
30-7246	30	Access Hole	855
30-7044	30	Anchor Counterbore	857
30-7059	30	Tap Profile End	854
30-7034	30	Bolt Connector	872

30-3001 Profile

30-3001 is a 30mm x 30mm metric 30 series square T-slot profile with one open T-slot on one 30mm face. The profile is smooth, which makes it resistant to dirt and debris buildup while also being easy to clean. The 30-3001 profile is compatible with 30 series fasteners. The three closed faces on this profile provide a clean, aesthetic look and it lends itself to furniture, displays, desks, trade show booths, or retail kiosks.

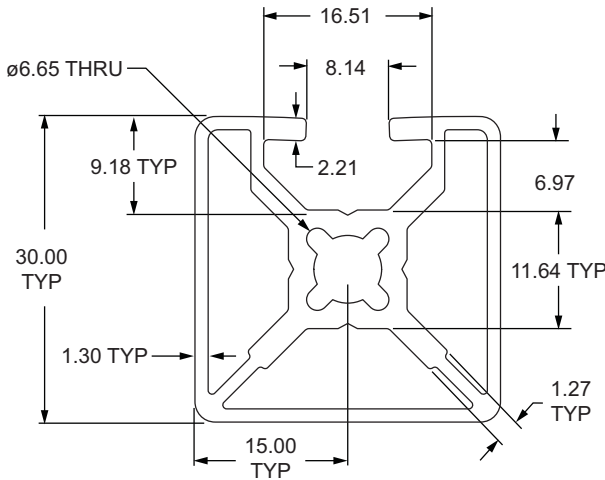

Part No.	Series	Stock Length	Material	Alloy**	Finish	Drop Lock	Moment of Inertia	Surface Area	Yield Strength	Modulus of Elasticity	Weight
30-3001 *	30	4 or 6 Meter	Aluminum	6105-T5	Clear Anodize	2°	IX = 2.7176 cm ⁴ IY = 2.6691 cm ⁴	3.067 cm ²	241.1 N / mm ²	70,326.5 N / mm ²	0.8220 kg / m
30-3001-Black-FB		per millimeter			Black Anodize						

* The above profiles are sold per millimeter or stock length.

** Or comparable

Standard Machining Services

Service No.	Series	Service Description	Reference Page
30-7010	30	Cut to Length	851
30-7246	30	Access Hole	855
30-7044	30	Anchor Counterbore	857
30-7059	30	Tap Profile End	854
30-7034	30	Bolt Connector	872

30mm X 30mm T-Slotted Profile - Two Adjacent Open T-Slots

30-3002 Profile

30-3002 is a 30mm x 30mm metric 30 series square T-slot profile with two adjacent open T-slots, one on two 30mm faces. The profile is smooth, which makes it resistant to dirt and debris buildup while also being easy to clean. The 30-3002 profile is compatible with 30 series fasteners. The two closed faces on this profile provide a clean, aesthetic look while also having the capability to mount additional profiles, parts and accessories. It lends itself to furniture, displays, desks, trade show booths, or retail kiosks.

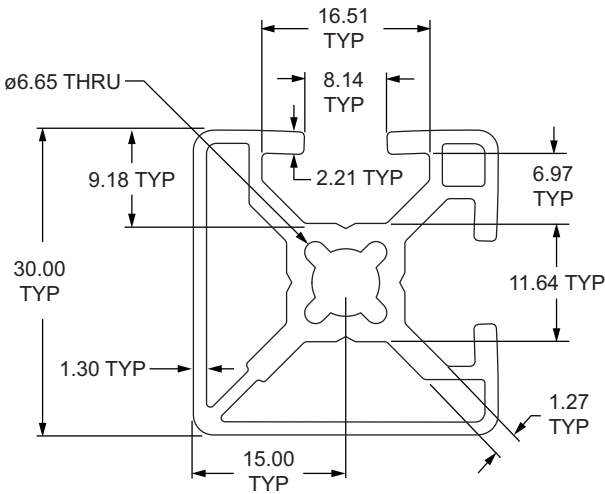

Part No.	Series	Stock Length	Material	Alloy**	Finish	Drop Lock	Moment of Inertia	Surface Area	Yield Strength	Modulus of Elasticity	Weight
30-3002 *	30	4 or 6 Meter	Aluminum	6105-T5	Clear Anodize	2°	IX = 2.6758 cm ⁴ IY = 2.6758 cm ⁴	3.066 cm ²	241.1 N / mm ²	70,326.5 N / mm ²	0.8217 kg / m
30-3002-Black-FB		per millimeter			Black Anodize						

* The above profiles are sold per millimeter or stock length.

** Or comparable

Standard Machining Services

Service No.	Series	Service Description	Reference Page
30-7010	30	Cut to Length	851
30-7246	30	Access Hole	855
30-7044	30	Anchor Counterbore	857
30-7059	30	Tap Profile End	854
30-7034	30	Bolt Connector	872

80/20[®] 30mm X 30mm T-Slotted Profile - Three Adjacent Open T-Slots

30-3003 Profile

30-3003 is a 30mm x 30mm metric 30 series square T-slot profile with three adjacent open T-slots, one on three 30mm faces. The profile is smooth, which makes it resistant to dirt and debris buildup while also being easy to clean. The 30-3003 profile is compatible with 30 series fasteners. The three closed faces on this profile provide a clean, aesthetic look while also having the capability to mount additional profiles, parts and accessories. It lends itself to furniture, displays, desks, trade show booths, or retail kiosks.

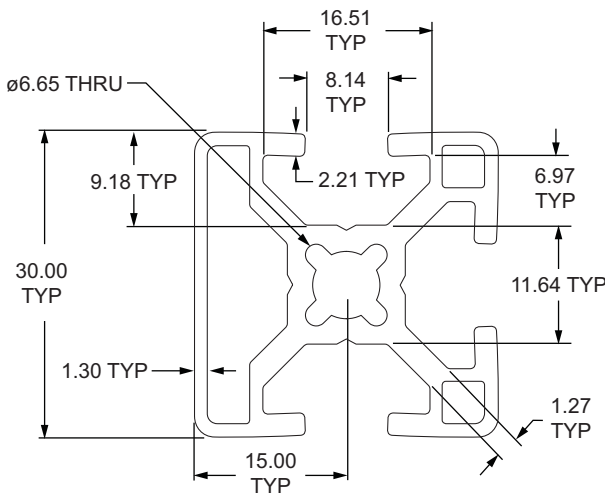

Part No.	Series	Stock Length	Material	Alloy**	Finish	Drop Lock	Moment of Inertia	Surface Area	Yield Strength	Modulus of Elasticity	Weight
30-3003 *	30	4 or 6 Meter	Aluminum	6105-T5	Clear Anodize	2°	IX = 2.6832 cm ⁴ IY = 2.6343 cm ⁴	3.065 cm ²	241.1 N / mm ²	70,326.5 N / mm ²	0.8214 kg / m
30-3003-Black-FB		per millimeter			Black Anodize						

* The above profiles are sold per millimeter or stock length.

** Or comparable

Standard Machining Services

Service No.	Series	Service Description	Reference Page
30-7010	30	Cut to Length	851
30-7246	30	Access Hole	855
30-7044	30	Anchor Counterbore	857
30-7059	30	Tap Profile End	854
30-7034	30	Bolt Connector	872

30mm X 30mm T-Slotted Profile - Two Opposite Open T-Slots

30-3004 Profile

30-3004 is a 30mm x 30mm metric 30 series square T-slot profile with two opposite open T-slots, one on two 30mm faces. The profile is smooth, which makes it resistant to dirt and debris buildup while also being easy to clean. The 30-3004 profile is compatible with 30 series fasteners. The placement of the T-slots allow support structures or panels to be easily placed into them while maintaining a continuous surface, lending itself to projects such as guarding, furniture or displays.

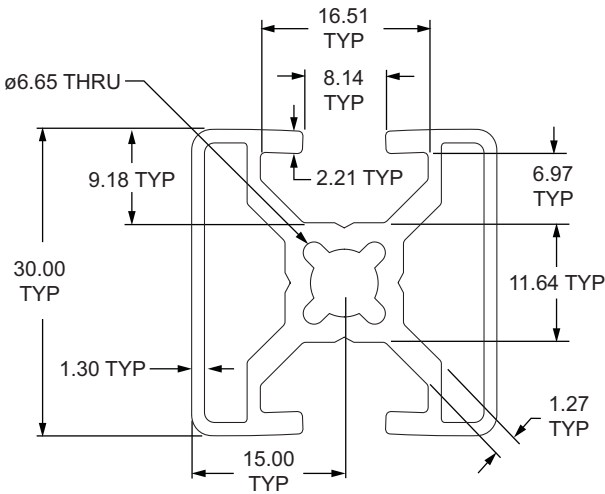

Part No.	Series	Stock Length	Material	Alloy**	Finish	Drop Lock	Moment of Inertia	Surface Area	Yield Strength	Modulus of Elasticity	Weight
30-3004 *	30	4 or 6 Meter	Aluminum	6105-T5	Clear Anodize	2°	IX = 2.6212 cm ⁴ IY = 2.5234 cm ⁴	2.986 cm ²	241.1 N / mm ²	70,326.5 N / mm ²	0.8002 kg / m
30-3004-Black-FB		per millimeter			Black Anodize						

* The above profiles are sold per millimeter or stock length.

** Or comparable

Standard Machining Services

Service No.	Series	Service Description	Reference Page
30-7010	30	Cut to Length	851
30-7246	30	Access Hole	855
30-7044	30	Anchor Counterbore	857
30-7059	30	Tap Profile End	854
30-7034	30	Bolt Connector	872

80/20® 30mm X 30mm Quarter Round T-Slotted Profile - Two Open T-Slots

30-3022 Profile

30-3022 is a 30mm x 30mm metric 30 series quarter round T-slot profile with a 22mm radius curved back and two open T-slots, one on each of the 30mm profile faces. The profile is smooth, which makes it resistant to dirt and debris buildup while also being easy to clean. The 30-3022 profile is compatible with 30 series fasteners. This profile lends itself to workstations and displays because panels or other support structures can be easily placed in the T-slots allowing a continuous surface and aesthetic appearance.

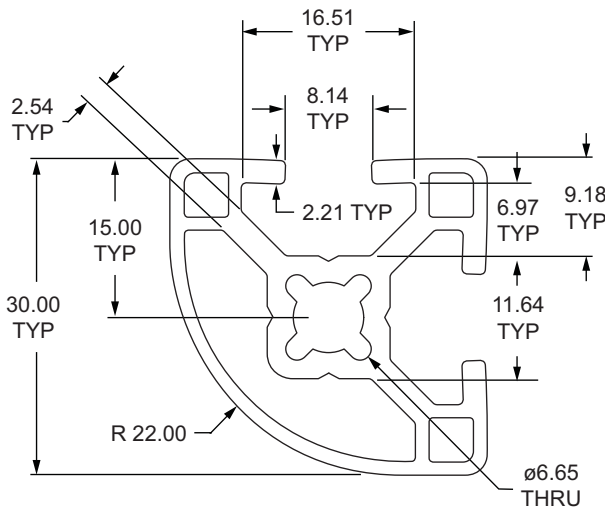

Part No.	Series	Stock Length	Material	Alloy**	Finish	Drop Lock	Moment of Inertia	Surface Area	Yield Strength	Modulus of Elasticity	Weight
30-3022 *	30	4 or 6 Meter	Aluminum	6105-T5	Clear Anodize	2°	IX = 2.2948 cm ⁴ IY = 2.2948 cm ⁴	2.840 cm ²	241.1 N / mm ²	70,326.5 N / mm ²	0.7612 kg / m
30-3022-Black-FB		per millimeter			Black Anodize						

* The above profiles are sold per millimeter or stock length.

** Or comparable

Standard Machining Services

Service No.	Series	Service Description	Reference Page
30-7010	30	Cut to Length	851
30-7246	30	Access Hole	855
30-7044	30	Anchor Counterbore	857
30-7059	30	Tap Profile End	854
30-7034	30	Bolt Connector	872

30mm X 60mm T-Slotted Profile - Six Open T-Slots

30-3060 Profile

30-3060 is a 30mm x 60mm metric 30 series rectangular T-slot profile with six open T-slots, two on each 60mm face and one on each 30mm face. The profile is smooth, which makes it resistant to dirt and debris buildup while also being easy to clean. The 30-3060 profile is compatible with 30 series fasteners and lends itself to work spaces, machine guards and displays.

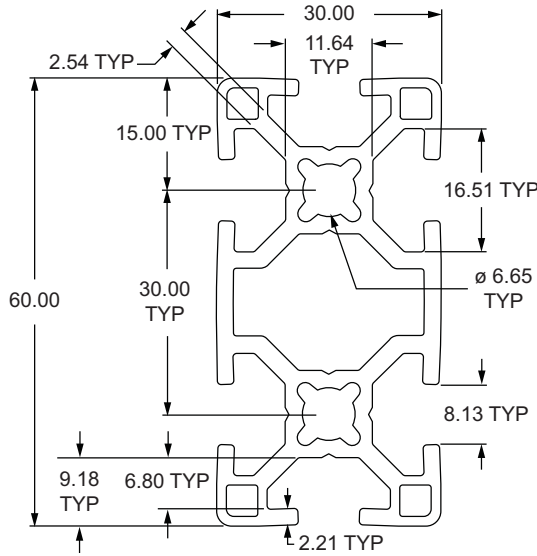

Part No.	Series	Stock Length	Material	Alloy**	Finish	Drop Lock	Moment of Inertia	Surface Area	Yield Strength	Modulus of Elasticity	Weight
30-3060 *	30	4 or 6 Meter	Aluminum	6105-T5	Clear Anodize	2°	IX = 5.4332 cm ⁴ IY = 19.6933 cm ⁴	5.928 cm ²	241.1 N / mm ²	70,326.5 N / mm ²	1.6428 kg / m
30-3060-Black-FB		per millimeter			Black Anodize						

* The above profiles are sold per millimeter or stock length.

** Or comparable

Standard Machining Services

Service No.	Series	Service Description	Reference Page
30-7020	30	Cut to Length	851
30-7246	30	Access Hole	855
30-7044	30	Anchor Counterbore	857
30-7048	30	Tap Profile End	854

30-6060 Profile

30-6060 is a 60mm x 60mm metric 30 series square T-slot profile with eight open T-slots, two on each 60mm face. The profile is smooth, which makes it resistant to dirt and debris buildup while also being easy to clean. The 30-6060 profile is compatible with 30 series fasteners. The eight open T-slots and strength make it a great choice for automation applications, machine frames and workstations.

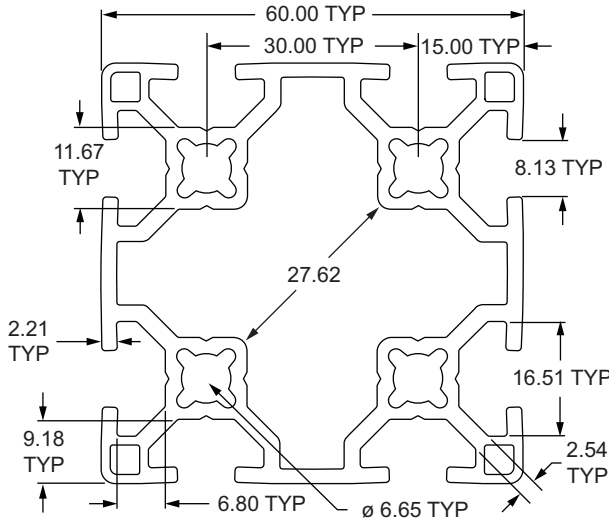

Part No.	Series	Stock Length	Material	Alloy**	Finish	Drop Lock	Moment of Inertia	Surface Area	Yield Strength	Modulus of Elasticity	Weight
30-6060 *	30	4 or 6 Meter	Aluminum	6105-T5	Clear Anodize	2°	IX = 36.3307 cm ⁴ IY = 36.3307 cm ⁴	9.299 cm ²	241.1 N / mm ²	70,326.5 N / mm ²	2.5787 kg / m
30-6060-Black-FB		per millimeter			Black Anodize						

* The above profiles are sold per millimeter or stock length.

** Or comparable

Standard Machining Services

Service No.	Series	Service Description	Reference Page
30-7030	30	Cut to Length	851
30-7246	30	Access Hole	855
30-7044	30	Anchor Counterbore	857
30-7056	30	Tap Profile End	854

40mm X 40mm Ultra-Lite T-Slotted Profile - Four Open T-Slots

40-4040-UL Profile

40-4040-UL is a 40mm x 40mm ultra-lite metric 40 series square T-slot profile with four open T-slots, one on each 40mm face. The profile is smooth, which makes it resistant to dirt and debris buildup while also being easy to clean. The 40-4040-UL profile is compatible with all 40 series fasteners. This profile lends itself to clean room applications, guards, enclosures, or work stations. The four open T-slots enable access from any direction and are useful for mounting accessories.

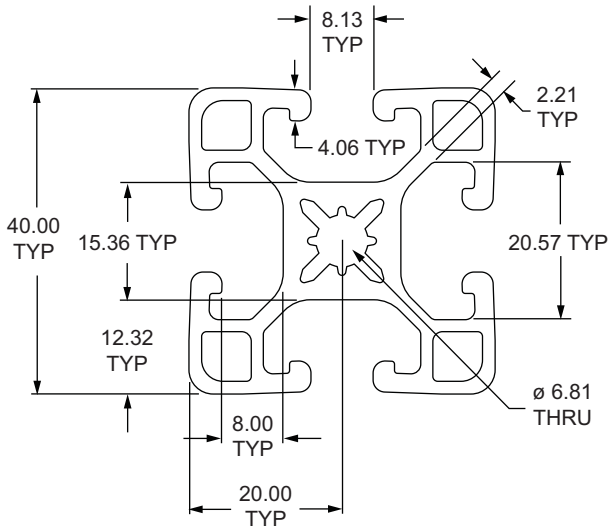

Part No.	Series	Stock Length	Material	Alloy**	Finish	Drop Lock	Moment of Inertia	Surface Area	Yield Strength	Modulus of Elasticity	Weight
40-4040-UL *		4 or 6 Meter	Aluminum	6105-T5	Clear Anodize	2°	IX = 8.7059 cm ⁴ IY = 8.7059 cm ⁴	5.750 cm ²	241.1 N / mm ²	70,326.5 N / mm ²	1.5533 kg / m
40-4040-UL-Black *	40	4 Meter			Black Anodize						
40-4040-UL-Black-FB		per millimeter			Black Anodize						

* The above profiles are sold per millimeter or stock length.

** Or comparable

Standard Machining Services

Service No.	Series	Service Description	Reference Page
40-7010	40	Cut to Length	851
40-7050	40	Access Hole	855
40-7044	40	Anchor Counterbore	857
40-7059	40	Tap Profile End	854

40-4040-Lite Profile

40-4040-Lite is a 40mm x 40mm lite metric 40 series square T-slot profile with four open T-slots, one on each 40mm face. The profile is smooth, which makes it resistant to dirt and debris buildup while also being easy to clean. The 40-4040-Lite profile is compatible with all 40 series fasteners. This profile lends itself to machine guards, enclosures, work benches, or displays. The four open T-slots enable access from any direction and are useful for mounting accessories.

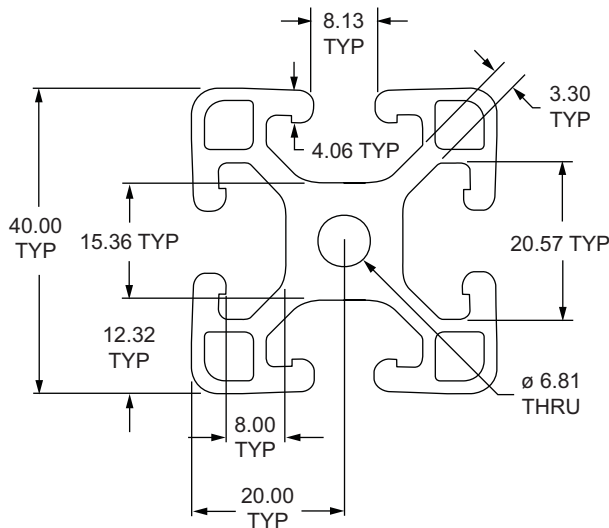

Part No.	Series	Stock Length	Material	Alloy**	Finish	Drop Lock	Moment of Inertia	Surface Area	Yield Strength	Modulus of Elasticity	Weight
40-4040-Lite *		4 or 6 Meter			Clear Anodize	2°	IX = 9.3983 cm ⁴ IY = 9.3983 cm ⁴	6.608 cm ²	241.1 N / mm ²	70,326.5 N / mm ²	1.7860 kg / m
40-4040-Lite-Black *	40	4 Meter	Aluminum	6105-T5	Black Anodize						
40-4040-Lite-Black-FB		per millimeter			Black Anodize						

* The above profiles are sold per millimeter or stock length.

** Or comparable

Standard Machining Services

Service No.	Series	Service Description	Reference Page
40-7010	40	Cut to Length	851
40-7050	40	Access Hole	855
40-7044	40	Anchor Counterbore	857
40-7059	40	Tap Profile End	854

40mm X 40mm T-Slotted Profile - Four Open T-Slots

40-4040 Profile

40-4040 is a 40mm x 40mm metric 40 series square T-slot profile with four open T-slots, one on each 40mm face. The profile is smooth, which makes it resistant to dirt and debris buildup while also being easy to clean. The 40-4040 profile is compatible with all 40 series fasteners. This profile is the most heavy-duty in the 40-4040 profile family and lends itself to clean room applications, guards, enclosures, or workstations. The four open T-slots enable access from any direction and are useful for mounting accessories.

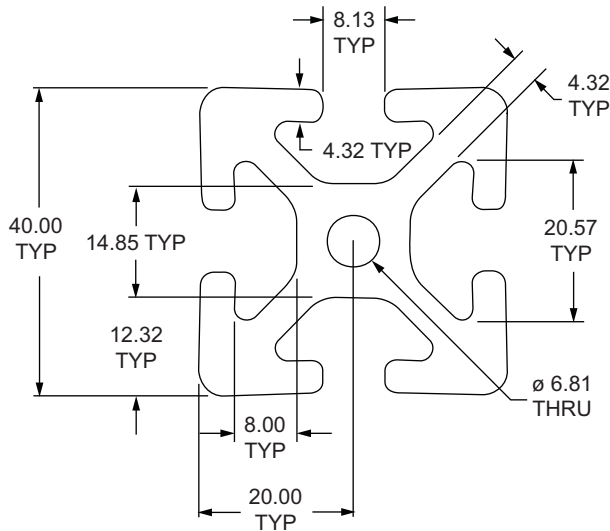

Part No.	Series	Stock Length	Material	Alloy**	Finish	Drop Lock	Moment of Inertia	Surface Area	Yield Strength	Modulus of Elasticity	Weight
40-4040 *		4 or 6 Meter	Aluminum	6105-T5	Clear Anodize	2°	IX = 13.7870 cm ⁴ IY = 13.7870 cm ⁴	8.742 cm ²	241.1 N / mm ²	70,326.5 N / mm ²	2.3640 kg / m
40-4040-Black *	40	4 Meter			Black Anodize						
40-4040-Black-FB		per millimeter			Black Anodize						

* The above profiles are sold per millimeter or stock length.

** Or comparable

Standard Machining Services

Service No.	Series	Service Description	Reference Page
40-7010	40	Cut to Length	851
40-7050	40	Access Hole	855
40-7044	40	Anchor Counterbore	857
40-7059	40	Tap Profile End	854

40-4001 Profile

40-4001 is a 40mm x 40mm metric 40 series square T-slot profile with one open T-slot on one 40mm face. The profile is smooth, which makes it resistant to dirt and debris buildup while also being easy to clean. The 40-4001 profile is compatible with 40 series fasteners. The three closed faces on this profile provide a clean, aesthetic look and it lends itself to furniture, displays, desks, trade show booths, or retail kiosks.

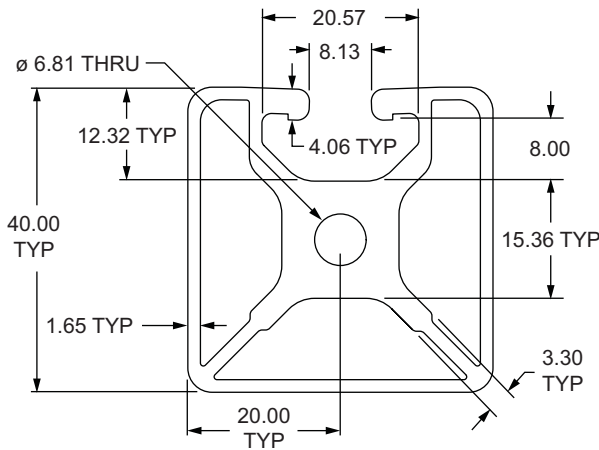

Part No.	Series	Stock Length	Material	Alloy**	Finish	Drop Lock	Moment of Inertia	Surface Area	Yield Strength	Modulus of Elasticity	Weight
40-4001 *	40	4 or 6 Meter	Aluminum	6105-T5	Clear Anodize	2°	IX = 8.5389 cm ⁴ IY = 8.2599 cm ⁴	5.968 cm ²	241.1 N / mm ²	70,326.5 N / mm ²	1.6142 kg / m
40-4001-Black-FB		per millimeter			Black Anodize						

* The above profiles are sold per millimeter or stock length.

** Or comparable

Standard Machining Services

Service No.	Series	Service Description	Reference Page
40-7010	40	Cut to Length	851
40-7050	40	Access Hole	855
40-7044	40	Anchor Counterbore	857
40-7059	40	Tap Profile End	854

40mm X 40mm T-Slotted Profile - Two Adjacent Open T-Slots

40-4002 Profile

40-4002 is a 40mm x 40mm metric 40 series square T-slot profile with two adjacent open T-slots, one on two 40mm faces. The profile is smooth, which makes it resistant to dirt and debris buildup while also being easy to clean. The 40-4002 profile is compatible with 40 series fasteners. The two closed faces on this profile provide a clean, aesthetic look and lends itself to furniture, displays, desks, trade show booths, or retail kiosks.

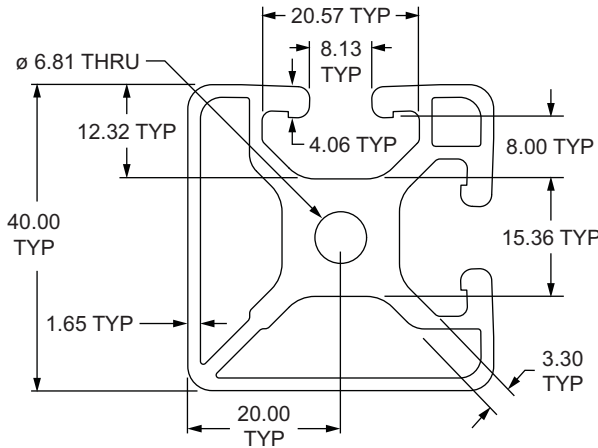

Part No.	Series	Stock Length	Material	Alloy**	Finish	Drop Lock	Moment of Inertia	Surface Area	Yield Strength	Modulus of Elasticity	Weight
40-4002 *		4 or 6 Meter	Aluminum	6105-T5	Clear Anodize	2°	IX = 8.6303 cm ⁴ IY = 8.6303 cm ⁴	6.118 cm ²	241.1 N / mm ²	70,326.5 N / mm ²	1.6535 kg / m
NEW 40-4002-Black *	40	4 Meter			Black Anodize						
40-4002-Black-FB		per millimeter			Black Anodize						

* The above profiles are sold per millimeter or stock length.

** Or comparable

Standard Machining Services

Service No.	Series	Service Description	Reference Page
40-7010	40	Cut to Length	851
40-7050	40	Access Hole	855
40-7044	40	Anchor Counterbore	857
40-7059	40	Tap Profile End	854

80/20®
40mm X 40mm T-Slotted Profile - Three Adjacent Open T-Slots

40-4003 Profile

40-4003 is a 40mm x 40mm metric 40 series square T-slot profile with three adjacent open T-slots, one on three 40mm faces. The profile is smooth, which makes it resistant to dirt and debris buildup while also being easy to clean. The 40-4003 profile is compatible with 40 series fasteners. The closed face on this profile provides a clean, aesthetic look while also having the capability to mount additional profiles, parts and accessories. It lends itself to furniture, displays, desks, trade show booths, or retail kiosks.

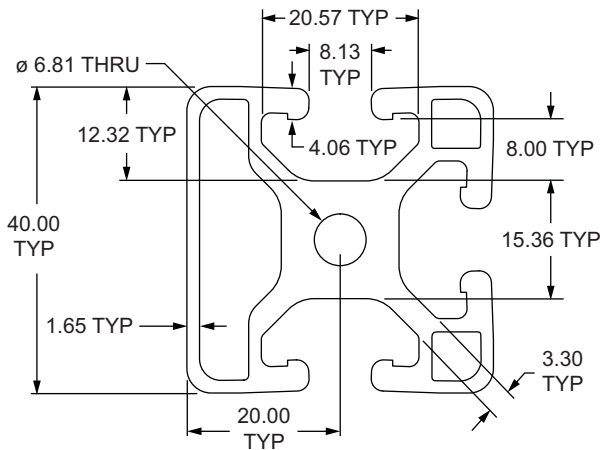

Part No.	Series	Stock Length	Material	Alloy**	Finish	Drop Lock	Moment of Inertia	Surface Area	Yield Strength	Modulus of Elasticity	Weight
40-4003 *		4 or 6 Meter			Clear Anodize	2°	IX = 9.0094 cm ⁴ IY = 8.7823 cm ⁴	6.268 cm ²	241.1 N / mm ²	70,326.5 N / mm ²	1.6947 kg / m
NEW 40-4003-Black *	40	4 Meter	Aluminum	6105-T5	Black Anodize						
40-4003-Black-FB		per millimeter			Black Anodize						

* The above profiles are sold per millimeter or stock length.

** Or comparable

Standard Machining Services

Service No.	Series	Service Description	Reference Page
40-7010	40	Cut to Length	851
40-7050	40	Access Hole	855
40-7044	40	Anchor Counterbore	857
40-7059	40	Tap Profile End	854

40mm X 40mm T-Slotted Profile - Two Opposite Open T-Slots

40-4004 Profile

40-4004 is a 40mm x 40mm metric 40 series square T-slot profile with two opposite open T-slots, one on two 40mm faces. The profile is smooth, which makes it resistant to dirt and debris buildup while also being easy to clean. The 40-4004 profile is compatible with 40 series fasteners. The placement of the T-slots allow support structures or panels to be easily placed into them while maintaining a continuous surface, lending itself to projects such as guarding, furniture or displays.

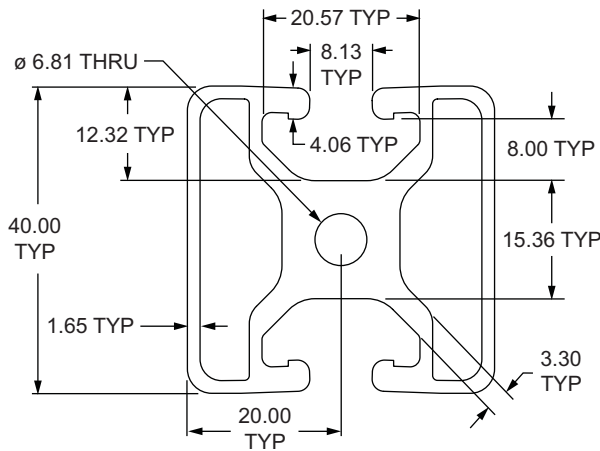

Part No.	Series	Stock Length	Material	Alloy**	Finish	Drop Lock	Moment of Inertia	Surface Area	Yield Strength	Modulus of Elasticity	Weight
40-4004 *	40	4 or 6 Meter	Aluminum	6105-T5	Clear Anodize	2°	IX = 8.6050 cm ⁴ IY = 8.0430 cm ⁴	5.954 cm ²	241.1 N / mm ²	70,326.5 N / mm ²	1.6106 kg / m
40-4004-Black-FB		per millimeter			Black Anodize						

* The above profiles are sold per millimeter or stock length.

** Or comparable

Standard Machining Services

Service No.	Series	Service Description	Reference Page
40-7010	40	Cut to Length	851
40-7050	40	Access Hole	855
40-7044	40	Anchor Counterbore	857
40-7059	40	Tap Profile End	854

40mm X 40mm Quarter Round Lite T-Slotted Profile - Two Open T-Slots

40-4030-Lite Profile

40-4030-Lite is a 40mm x 40mm metric 40 series quarter round T-slot profile with a 30mm radius curved back and two open T-slots, one on each of the 40mm profile faces. The profile is smooth, which makes it resistant to dirt and debris buildup while also being easy to clean. The 40-4030-Lite profile is compatible with 40 series fasteners. This profile lends itself to workstations and displays because panels or other support structures can be easily placed in the T-slots allowing a continuous surface and aesthetic appearance.

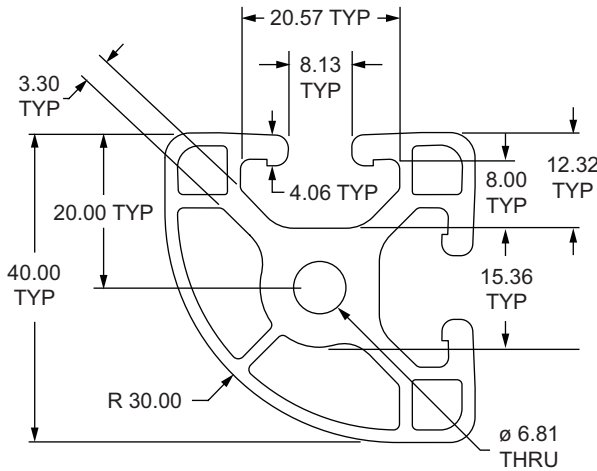

Part No.	Series	Stock Length	Material	Alloy**	Finish	Drop Lock	Moment of Inertia	Surface Area	Yield Strength	Modulus of Elasticity	Weight
40-4030-Lite *	40	4 or 6 Meter	Aluminum	6105-T5	Clear Anodize	2°	IX = 7.5590 cm ⁴ IY = 7.5590 cm ⁴	5.729 cm ²	241.1 N / mm ²	70,326.5 N / mm ²	1.5497 kg / m
40-4030-Lite-Black-FB		per millimeter			Black Anodize						

* The above profiles are sold per millimeter or stock length.

** Or comparable

Standard Machining Services

Service No.	Series	Service Description	Reference Page
40-7010	40	Cut to Length	851
40-7050	40	Access Hole	855
40-7044	40	Anchor Counterbore	857
40-7059	40	Tap Profile End	854

40mm T-slotted Profile 30 Degree Radius - Two Opposite Open T-Slots

40-4093 Profile

40-4093 is a 40mm metric 40 series T-slot profile with a 30 degree radius and two opposite open T-slots, one on each of the 40mm profile faces. The profile is smooth, which makes it resistant to dirt and debris buildup while also being easy to clean. The 40-4093 profile is compatible with 40 series fasteners. This profile lends itself to workstations and displays because it provides an aesthetic appearance and panels or other support structures can be easily placed in the T-slots.

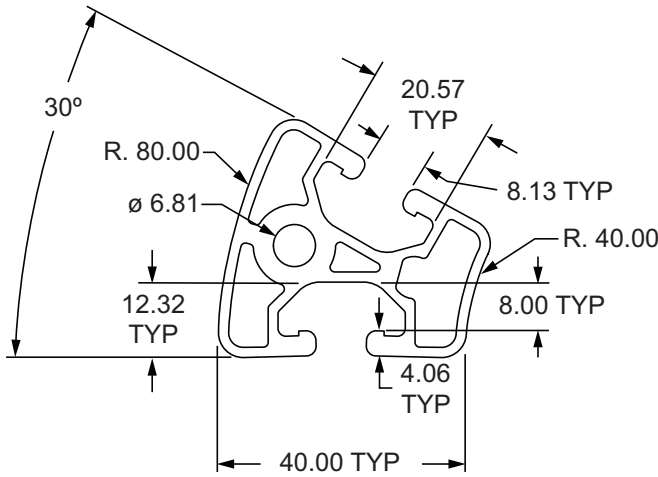

Part No.	Series	Stock Length	Material	Alloy**	Finish	Drop Lock	Moment of Inertia	Surface Area	Yield Strength	Modulus of Elasticity	Weight
40-4093 *	40	4 Meter	Aluminum	6105-T5	Clear Anodize	2°	—	4.711 cm ²	241.1 N / mm ²	70,326.5 N / mm ²	1.2742 kg / m
40-4093-Black-FB		per millimeter			Black Anodize						

* The above profiles are sold per millimeter or stock length.

** Or comparable

Standard Machining Services

Service No.	Series	Service Description	Reference Page
40-7020	40	Cut to Length	851
40-7059	40	Tap Profile End	854

80/20®
40mm T-slotted Profile 45 Degree Radius - Two Opposite Open T-Slots

40-4094 Profile

40-4094 is a 40mm metric 40 series T-slot profile with a 45 degree radius and two opposite open T-slots, one on each of the 40mm profile faces. The profile is smooth, which makes it resistant to dirt and debris buildup while also being easy to clean. The 40-4094 profile is compatible with 40 series fasteners. This profile lends itself to workstations and displays because panels or other support structures can be easily placed in the T-slots allowing a continuous surface and aesthetic appearance.

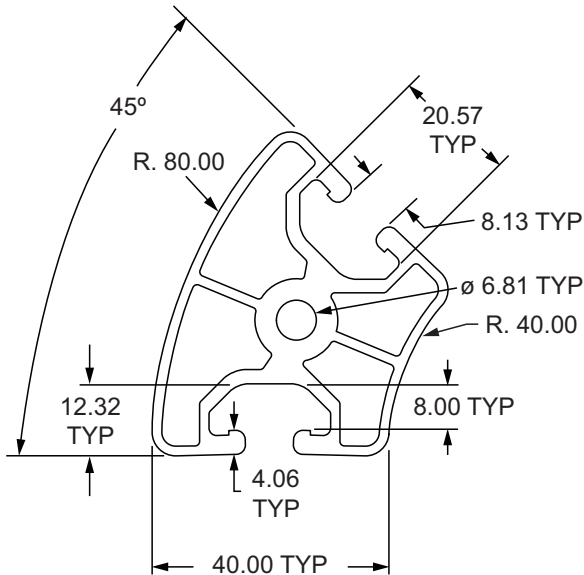

Part No.	Series	Stock Length	Material	Alloy**	Finish	Drop Lock	Moment of Inertia	Surface Area	Yield Strength	Modulus of Elasticity	Weight
40-4094 *	40	4 Meter	Aluminum	6105-T5	Clear Anodize	2°	—	6.309 cm ²	241.1 N / mm ²	70,326.5 N / mm ²	1.7054 kg / m
NEW 40-4094-Black *		4 Meter			Black Anodize						
40-4094-Black-FB		per millimeter			Black Anodize						

* The above profiles are sold per millimeter or stock length.

** Or comparable

Standard Machining Services

Service No.	Series	Service Description	Reference Page
40-7020	40	Cut to Length	851
40-7059	40	Tap Profile End	854

40mm T-slotted Profile 60 Degree Radius - Two Opposite Open T-Slots

40-4096 Profile

40-4096 is a 40mm metric 40 series T-slot profile with a 60 degree radius and two opposite open T-slots, one on each of the 40mm profile faces. The profile is smooth, which makes it resistant to dirt and debris buildup while also being easy to clean. The 40-4096 profile is compatible with 40 series fasteners. This profile lends itself to workstations, kiosks or point of purchase displays because panels or other support structures can be easily placed in the T-slots allowing a continuous surface and aesthetic appearance.

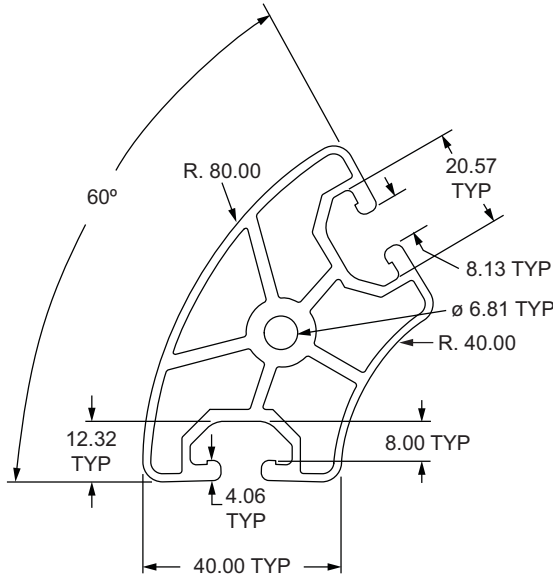

Part No.	Series	Stock Length	Material	Alloy**	Finish	Drop Lock	Moment of Inertia	Surface Area	Yield Strength	Modulus of Elasticity	Weight
40-4096 *	40	4 Meter	Aluminum	6105-T5	Clear Anodize	2°	—	7.828 cm ²	241.1 N / mm ²	70,326.5 N / mm ²	2.1170 kg / m
40-4096-Black-FB		per millimeter			Black Anodize						

* The above profiles are sold per millimeter or stock length.

** Or comparable

Standard Machining Services

Service No.	Series	Service Description	Reference Page
40-7020	40	Cut to Length	851
40-7059	40	Tap Profile End	854

40mm X 40mm Lite 45 Degree T-Slotted Profile - Two Adjacent Open T-Slots

40-4045-Lite Profile

40-4045-Lite is a 40mm x 40mm metric 40 series 45 degree closed back T-slot profile with two open T-slots, one on each of the 40mm profile faces. The profile is smooth, which makes it resistant to dirt and debris buildup while also being easy to clean. The 40-4045-Lite profile is compatible with 40 series fasteners. This profile lends itself to large workstations and displays because panels or other support structures can be easily placed in the T-slots allowing a continuous surface and aesthetic appearance.

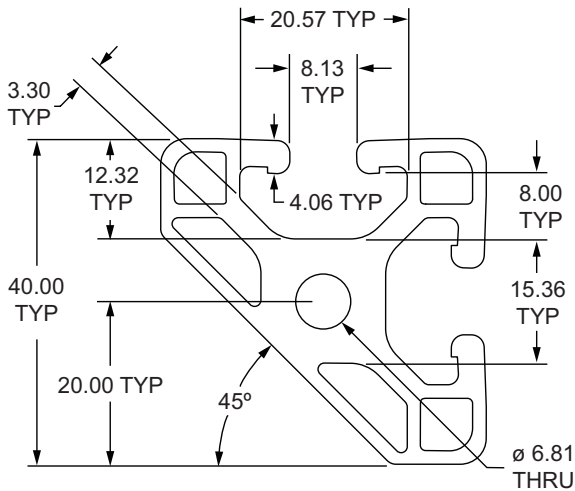

Part No.	Series	Stock Length	Material	Alloy**	Finish	Drop Lock	Moment of Inertia	Surface Area	Yield Strength	Modulus of Elasticity	Weight
40-4045-Lite *	40	4 or 6 Meter	Aluminum	6105-T5	Clear Anodize	2°	IX = 6.9991 cm ⁴ IY = 7.0047 cm ⁴	5.541 cm ²	241.1 N / mm ²	70,326.5 N / mm ²	1.4996 kg / m
40-4045-Lite-Black-FB		per millimeter			Black Anodize						

* The above profiles are sold per millimeter or stock length.

** Or comparable

Standard Machining Services

Service No.	Series	Service Description	Reference Page
40-7010	40	Cut to Length	851
40-7050	40	Access Hole	855
40-7044	40	Anchor Counterbore	857
40-7059	40	Tap Profile End	854

40mm X 20mm T-Slotted Profile - Single Open T-Slot

40-4020 Profile

40-4020 is a 40mm x 20mm metric 40 series rectangular T-slot profile with one open T-slot on one 40mm face. The profile is smooth, which makes it resistant to dirt and debris buildup while also being easy to clean. The 40-4020 profile is compatible with 40 series fasteners. It is a thinner profile that connects easily to flat surfaces and works well as a supporting structure or spacer for mounting accessories such as handles, door tracks, rails, valves or sensors.

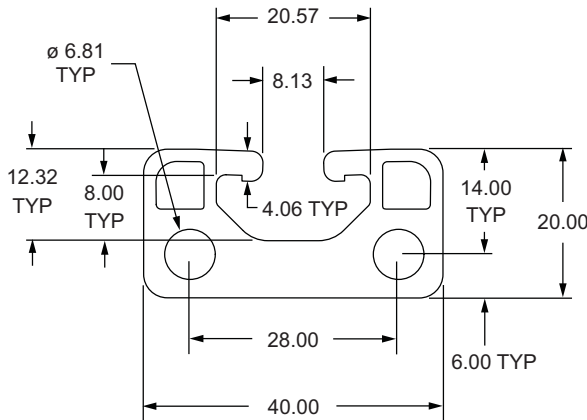

Part No.	Series	Stock Length	Material	Alloy**	Finish	Drop Lock	Moment of Inertia	Surface Area	Yield Strength	Modulus of Elasticity	Weight
40-4020 *	40	4 Meter	Aluminum	6105-T5	Clear Anodize	2°	IX = 1.8260 cm ⁴ IY = 6.6587 cm ⁴	4.550 cm ²	241.1 N / mm ²	70,326.5 N / mm ²	1.2312 kg / m
40-4020-Black-FB		per millimeter			Black Anodize						

* The above profiles are sold per millimeter or stock length.

** Or comparable

Standard Machining Services

Service No.	Series	Service Description	Reference Page
40-7010	40	Cut to Length	851
40-7050	40	Access Hole	855
40-7044	40	Anchor Counterbore	857
40-7015	40	Tap Profile End	854
40-7257	40	Drill Thru & Counterbore	858

40-8020 Profile

40-8020 is a 80mm x 20mm metric 40 series rectangular T-slot profile with two adjacent open T-slots, two on one 80mm face. The profile is smooth, which makes it resistant to dirt and debris buildup while also being easy to clean. The 40-8020 profile is compatible with 40 series fasteners. It is a thinner profile that connects easily to flat surfaces and works well as a supporting structure or spacer for mounting accessories such as handles, door tracks, rails, valves or sensors.

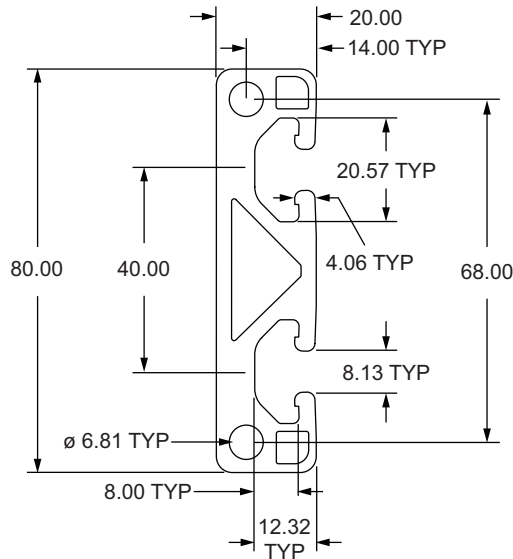

Part No.	Series	Stock Length	Material	Alloy**	Finish	Drop Lock	Moment of Inertia	Surface Area	Yield Strength	Modulus of Elasticity	Weight
40-8020 *	40	4 Meter	Aluminum	6105-T5	Clear Anodize	2°	IX = 49.6609 cm ⁴ IY = 3.7286 cm ⁴	8.482 cm ²	241.1 N / mm ²	70,326.5 N / mm ²	2.2960 kg / m
40-8020-Black-FB		per millimeter			Black Anodize						

* The above profiles are sold per millimeter or stock length.

** Or comparable

Standard Machining Services

Service No.	Series	Service Description	Reference Page
40-7020	40	Cut to Length	851
40-7050	40	Access Hole	855
40-7044	40	Anchor Counterbore	857
40-7017	40	Tap Profile End	854
40-7257	40	Drill Thru & Counterbore	858

40mm X 80mm Ultra-Lite T-Slotted Profile - Six Open T-Slots

40-4080-UL Profile

40-4080-UL is a 40mm x 80mm metric 40 series rectangular T-slot profile with six open T-slots, two on each 80mm face and one on each 40mm face. The profile is smooth, which makes it resistant to dirt and debris buildup while also being easy to clean. The 40-4080-UL profile is compatible with 40 series fasteners. It is the lightest in the 40-4080 profile family and the center cavity of the profile can be pressurized up to 1.034 N/mm² (150 psi), lending itself to work spaces, machine guards, displays and panel mount racks.

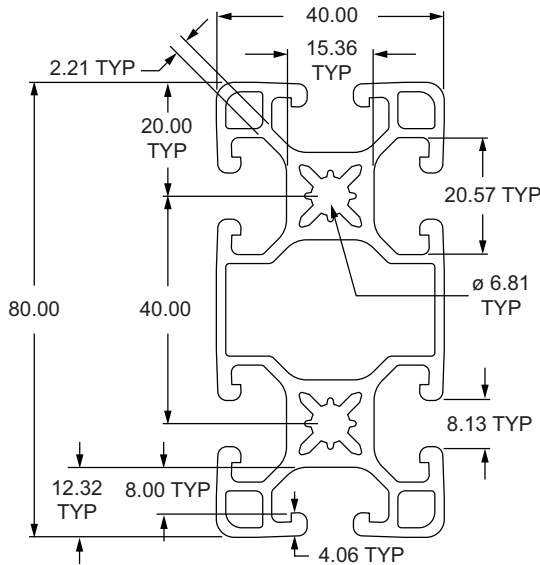

Part No.	Series	Stock Length	Material	Alloy**	Finish	Drop Lock	Moment of Inertia	Surface Area	Yield Strength	Modulus of Elasticity	Weight
40-4080-UL *	40	4 or 6 Meter	Aluminum	6105-T5	Clear Anodize	2°	IX = 63.1358 cm ⁴ IY = 15.4754 cm ⁴	9.792 cm ²	241.1 N / mm ²	70,326.5 N / mm ²	2.6485 kg / m
40-4080-UL-Black-FB		per millimeter			Black Anodize						

* The above profiles are sold per millimeter or stock length.

** Or comparable

Standard Machining Services

Service No.	Series	Service Description	Reference Page
40-7020	40	Cut to Length	851
40-7050	40	Access Hole	855
40-7044	40	Anchor Counterbore	857
40-7048	40	Tap Profile End	854

40-4080-Lite Profile

40-4080-Lite is a 40mm x 80mm metric 40 series rectangular T-slot profile with six open T-slots, two on each 80mm face and one on each 40mm face. The profile is smooth, which makes it resistant to dirt and debris buildup while also being easy to clean. The 40-4080-Lite profile is compatible with 40 series fasteners. The center cavity of the profile can be pressurized up to 1.034 N/mm² (150 psi), lending itself to work spaces, machine guards, displays and panel mount racks.

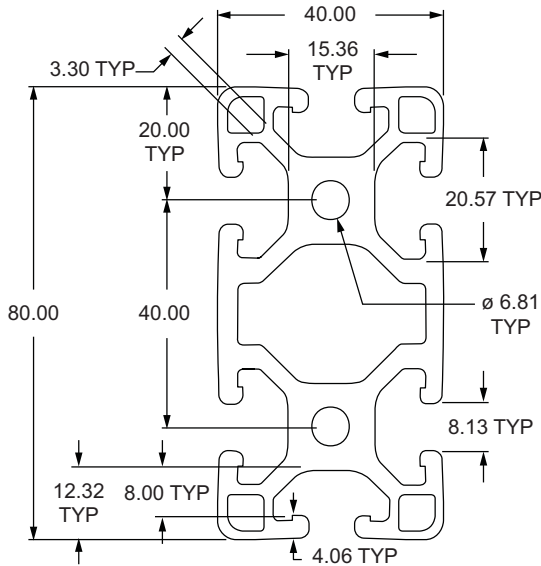

Part No.	Series	Stock Length	Material	Alloy**	Finish	Drop Lock	Moment of Inertia	Surface Area	Yield Strength	Modulus of Elasticity	Weight
40-4080-Lite *		4 or 6 Meter	Aluminum	6105-T5	Clear Anodize	2°	IX = 71.8926 cm ⁴ IY = 18.7791 cm ⁴	12.532 cm ²	241.1 N / mm ²	70,326.5 N / mm ²	3.3876 kg / m
40-4080-Lite-Black *	40	4 Meter			Black Anodize						
40-4080-Lite-Black-FB		per millimeter			Black Anodize						

* The above profiles are sold per millimeter or stock length.

** Or comparable

Standard Machining Services

Service No.	Series	Service Description	Reference Page
40-7020	40	Cut to Length	851
40-7050	40	Access Hole	855
40-7044	40	Anchor Counterbore	857
40-7048	40	Tap Profile End	854

40mm X 80mm T-Slotted Profile - Six Open T-Slots

40-4080 Profile

40-4080 is a 40mm x 80mm metric 40 series rectangular T-slot profile with six open T-slots, two on each 80mm face and one on each 40mm face. The profile is smooth, which makes it resistant to dirt and debris buildup while also being easy to clean. The 40-4080 profile is compatible with 40 series fasteners. It is the heavy-duty profile in the 40-4080 profile family and the center cavity of the profile can be pressurized up to 1.034 N/mm² (150 psi), lending itself to work spaces, machine guards, displays and panel mount racks.

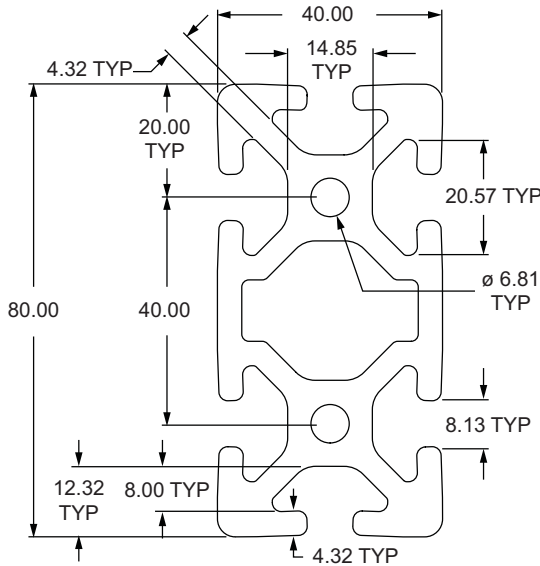

Part No.	Series	Stock Length	Material	Alloy**	Finish	Drop Lock	Moment of Inertia	Surface Area	Yield Strength	Modulus of Elasticity	Weight
40-4080 *	40	4 or 6 Meter	Aluminum	6105-T5	Clear Anodize	2°	IX = 97.6617 cm ⁴ IY = 25.2917 cm ⁴	15.332 cm ²	241.1 N / mm ²	70,326.5 N / mm ²	4.1464 kg / m
40-4080-Black *		4 Meter			Black Anodize						
40-4080-Black-FB		per millimeter			Black Anodize						

* The above profiles are sold per millimeter or stock length.

** Or comparable

Standard Machining Services

Service No.	Series	Service Description	Reference Page
40-7020	40	Cut to Length	851
40-7050	40	Access Hole	855
40-7044	40	Anchor Counterbore	857
40-7048	40	Tap Profile End	854

40mm X 80mm Lite T-Slotted Profile - Two Adjacent Open T-Slots

40-4082-Lite Profile

40-4082-Lite is a 40mm x 80mm lite metric 40 series rectangular T-slot profile with two adjacent open T-slots, two on one 80mm face. The profile is smooth, which makes it resistant to dirt and debris buildup while also being easy to clean. The 40-4082-Lite profile is compatible with 40 series fasteners. The three closed faces on this profile provide a clean, aesthetic look while the center cavity of the profile can be pressurized up to 1.034 N/mm² (150 psi), lending itself to work spaces, machine guards, displays and panel mount racks.

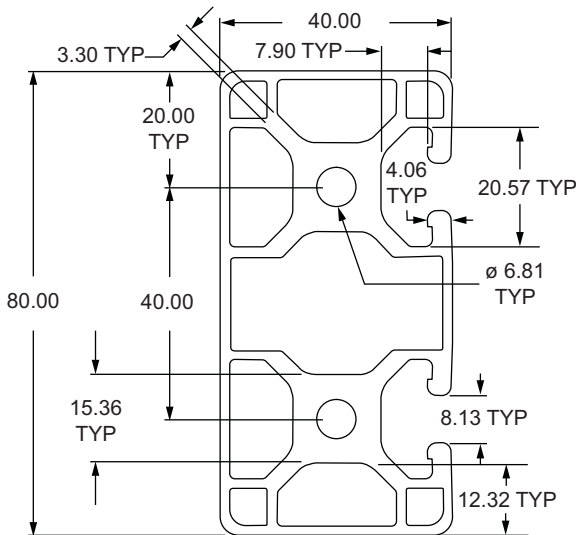

Part No.	Series	Stock Length	Material	Alloy**	Finish	Drop Lock	Moment of Inertia	Surface Area	Yield Strength	Modulus of Elasticity	Weight
40-4082-Lite *	40	4 or 6 Meter	Aluminum	6105-T5	Clear Anodize	2°	IX = 66.4788 cm ⁴ IY = 16.3044 cm ⁴	10.982 cm ²	241.1 N / mm ²	70,326.5 N / mm ²	2.9689 kg / m
40-4082-Lite-Black-FB		per millimeter			Black Anodize						

* The above profiles are sold per millimeter or stock length.

** Or comparable

Standard Machining Services

Service No.	Series	Service Description	Reference Page
40-7020	40	Cut to Length	851
40-7050	40	Access Hole	855
40-7044	40	Anchor Counterbore	857
40-7048	40	Tap Profile End	854

40mm X 80mm Lite T-Slotted Profile - Three Adjacent Open T-Slots

40-4083-Lite Profile

40-4083-Lite is a 40mm x 80mm lite metric 40 series rectangular T-slot profile with three adjacent open T-slots, two on one 80mm face and one on one 40mm face. The profile is smooth, which makes it resistant to dirt and debris buildup while also being easy to clean. The 40-4083-Lite profile is compatible with 40 series fasteners. The two closed faces on this profile provide a clean, aesthetic look while the center cavity of the profile can be pressurized up to 1.034 N/mm² (150 psi), lending itself to work spaces, machine guards and displays.

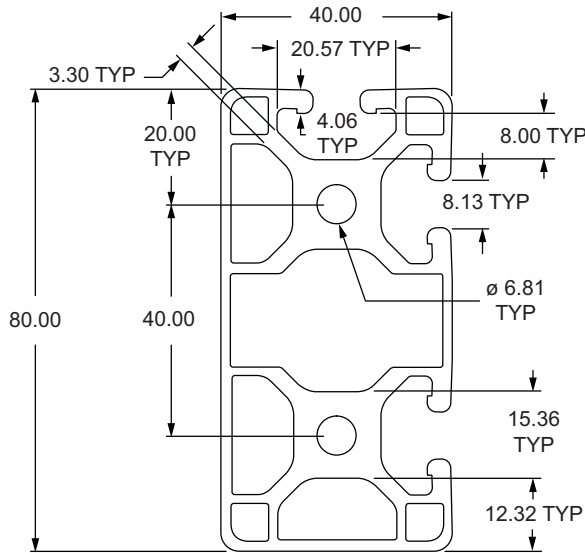

Part No.	Series	Stock Length	Material	Alloy**	Finish	Drop Lock	Moment of Inertia	Surface Area	Yield Strength	Modulus of Elasticity	Weight
40-4083-Lite *	40	4 or 6 Meter	Aluminum	6105-T5	Clear Anodize	2°	IX = 68.1908 cm ⁴ IY = 16.4684 cm ⁴	11.074 cm ²	241.1 N / mm ²	70,326.5 N / mm ²	2.9957 kg / m
40-4083-Lite-Black-FB		per millimeter			Black Anodize						

* The above profiles are sold per millimeter or stock length.

** Or comparable

Standard Machining Services

Service No.	Series	Service Description	Reference Page
40-7020	40	Cut to Length	851
40-7050	40	Access Hole	855
40-7044	40	Anchor Counterbore	857
40-7048	40	Tap Profile End	854

80/20® 40mm X 80mm Lite T-Slotted Profile - Four Adjacent Open T-Slots

40-4084-Lite Profile

40-4084-Lite is a 40mm x 80mm lite metric 40 series rectangular T-slot profile with four adjacent open T-slots, two on one 80mm face and one on each 40mm face. The profile is smooth, which makes it resistant to dirt and debris buildup while also being easy to clean. The 40-4084-Lite profile is compatible with 40 series fasteners. The closed face on this profile provides a clean, aesthetic look while the center cavity of the profile can be pressurized up to 1.034 N/mm² (150 psi), lending itself to work spaces, machine guards and displays.

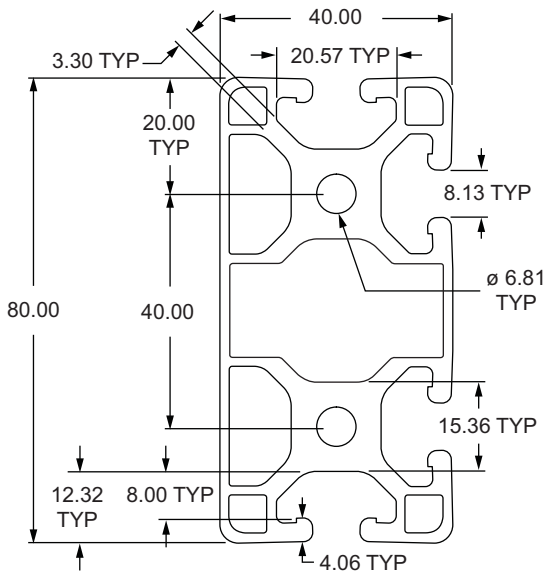

Part No.	Series	Stock Length	Material	Alloy**	Finish	Drop Lock	Moment of Inertia	Surface Area	Yield Strength	Modulus of Elasticity	Weight
40-4084-Lite *		4 or 6 Meter			Clear Anodize	2°	IX = 69.7265 cm ⁴ IY = 16.6107 cm ⁴	11.174 cm ²	241.1 N / mm ²	70,326.5 N / mm ²	3.0208 kg / m
NEW 40-4084-Lite-Black *	40	4 Meter	Aluminum	6105-T5	Black Anodize						
40-4084-Lite-Black-FB		per millimeter			Black Anodize						

* The above profiles are sold per millimeter or stock length.

** Or comparable

Standard Machining Services

Service No.	Series	Service Description	Reference Page
40-7020	40	Cut to Length	851
40-7050	40	Access Hole	855
40-7044	40	Anchor Counterbore	857
40-7048	40	Tap Profile End	854

40mm X 80mm Lite T-Slotted Profile - Two Opposite Open T-Slots

40-4085-Lite Profile

40-4085-Lite is a 40mm x 80mm lite metric 40 series rectangular T-slot profile with two open T-slots, one on each 40mm face. The profile is smooth, which makes it resistant to dirt and debris buildup while also being easy to clean. The 40-4085-Lite profile is compatible with 40 series fasteners. The closed faces on this profile provides a clean, aesthetic look while the center cavity of the profile can be pressurized up to 1.034 N/mm² (150 psi), lending itself to machine guards, enclosures, work benches, or displays.

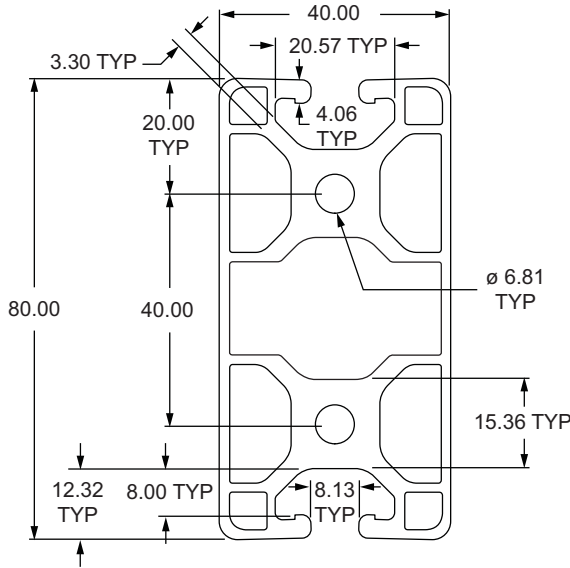

Part No.	Series	Stock Length	Material	Alloy**	Finish	Drop Lock	Moment of Inertia	Surface Area	Yield Strength	Modulus of Elasticity	Weight
40-4085-Lite *	40	4 or 6 Meter	Aluminum	6105-T5	Clear Anodize	2°	IX = 67.8369 cm ⁴ IY = 15.9404 cm ⁴	11.000 cm ²	241.1 N / mm ²	70,326.5 N / mm ²	2.9760 kg / m
40-4085-Lite-Black-FB		per millimeter			Black Anodize						

* The above profiles are sold per millimeter or stock length.

** Or comparable

Standard Machining Services

Service No.	Series	Service Description	Reference Page
40-7020	40	Cut to Length	851
40-7050	40	Access Hole	855
40-7044	40	Anchor Counterbore	857
40-7048	40	Tap Profile End	854

40mm X 120mm T-Slotted Profile - Eight Open T-Slots

40-4012 Profile

40-4012 is a 40mm x 120mm metric 40 series rectangular T-slot profile with eight open T-slots, three on each 120mm face and one on each 40mm face. The profile is smooth, which makes it resistant to dirt and debris buildup while also being easy to clean. The 40-4012 profile is compatible with 40 series fasteners and has center cavities that can be pressurized up to 1.034 N/mm² (150 psi). The eight open T-slots make this profile great for mounting accessories, flat plates and hinges. It lends itself to linear motion and machine frames.

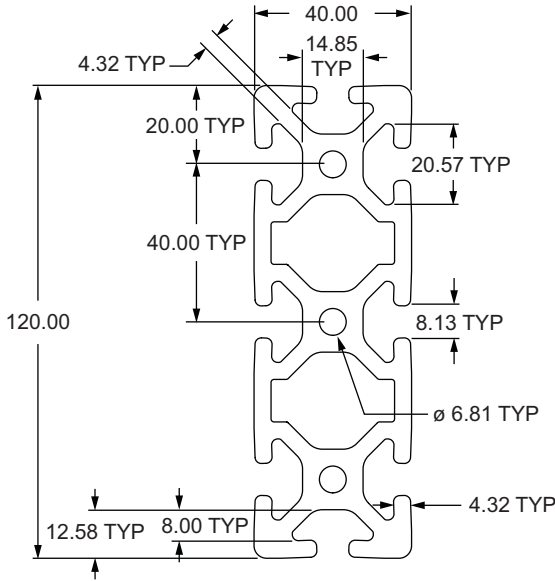

Part No.	Series	Stock Length	Material	Alloy**	Finish	Drop Lock	Moment of Inertia	Surface Area	Yield Strength	Modulus of Elasticity	Weight
40-4012 *	40	4 or 6 Meter	Aluminum	6105-T5	Clear Anodize	2°	IX = 306.3198 cm ⁴ IY = 36.8008 cm ⁴	21.927 cm ²	241.1 N / mm ²	70,326.5 N / mm ²	5.9306 kg / m
40-4012-Black-FB		per millimeter			Black Anodize						

* The above profiles are sold per millimeter or stock length.

** Or comparable

Standard Machining Services

Service No.	Series	Service Description	Reference Page
40-7021	40	Cut to Length	851
40-7050	40	Access Hole	855
40-7044	40	Anchor Counterbore	857
40-7028	40	Tap Profile End	854

80mm X 80mm T-Slotted Profile - Eight Open T-Slots

40-8080 Profile

40-8080 is a 80mm x 80mm metric 40 series square T-slot profile with eight open T-slots, two on each 80mm face. The profile is smooth, which makes it resistant to dirt and debris buildup while also being easy to clean. The 40-8080 profile is compatible with 40 series fasteners and has a center cavity that can be pressurized up to 1.034 N/mm² (150 psi). The eight open T-slots, strength, and ability to pressurize this profile make it a great choice for automation applications, machine frames and workstations.

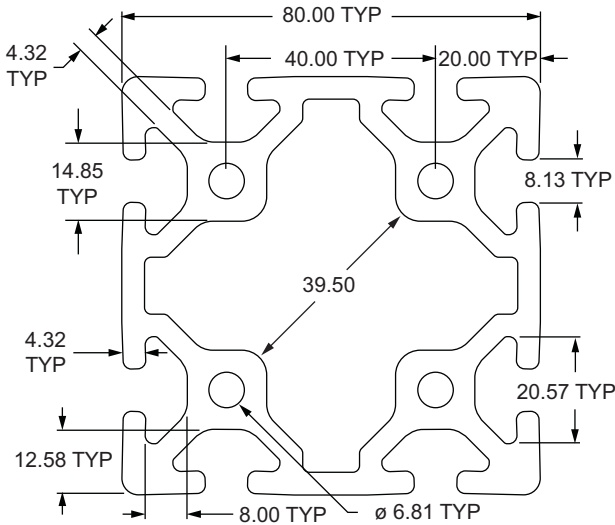

Part No.	Series	Stock Length	Material	Alloy**	Finish	Drop Lock	Moment of Inertia	Surface Area	Yield Strength	Modulus of Elasticity	Weight
40-8080 *		4 or 6 Meter	Aluminum	6105-T5	Clear Anodize	2°	IX = 171.6341 cm ⁴ IY = 171.6341 cm ⁴	23.573 cm ²	241.1 N / mm ²	70,326.5 N / mm ²	6.3762 kg / m
40-8080-Black *	40	4 Meter			Black Anodize						
40-8080-Black-FB		per millimeter			Black Anodize						

* The above profiles are sold per millimeter or stock length.

** Or comparable

Standard Machining Services

Service No.	Series	Service Description	Reference Page
40-7030	40	Cut to Length	851
40-7050	40	Access Hole	855
40-7044	40	Anchor Counterbore	857
40-7056	40	Tap Profile End	854

40-8016 Profile

40-8016 is a 80mm x 160mm metric 40 series rectangular T-slot profile with twelve open T-slots, two on each 80mm face and four on each 160mm face. The profile is smooth, which makes it resistant to dirt and debris buildup while also being easy to clean. The 40-8016 profile is compatible with 40 series fasteners, and has center cavities that can be pressurized up to 1.034 N/mm² (150 psi). The twelve open T-slots, strength, and ability to pressurize this profile make it a great choice for automation applications, machine frames and workstations.

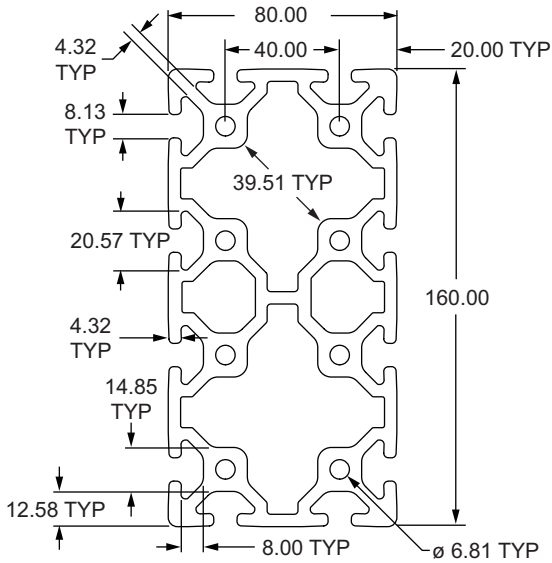

Part No.	Series	Stock Length	Material	Alloy**	Finish	Drop Lock	Moment of Inertia	Surface Area	Yield Strength	Modulus of Elasticity	Weight
40-8016 *	40	4 or 6 Meter	Aluminum	6105-T5	Clear Anodize	2°	IX = 1111.9793 cm ⁴ IY = 322.7985 cm ⁴	43.490 cm ²	241.1 N / mm ²	70,326.5 N / mm ²	11.7627 kg / m
40-8016-Black-FB		per millimeter			Black Anodize						

* The above profiles are sold per millimeter or stock length.

** Or comparable

Standard Machining Services

Service No.	Series	Service Description	Reference Page
40-7023	40	Cut to Length	851
40-7050	40	Access Hole	855
40-7044	40	Anchor Counterbore	857
40-7031	40	Tap Profile End	854

45mm X 45mm Lite T-Slotted Profile - Four Open T-Slots

45-4545-Lite Profile

45-4545-Lite is a 45mm x 45mm lite metric 45 series square T-slot profile with four open T-slots, one on each 45mm face. The profile is smooth, which makes it resistant to dirt and debris buildup while also being easy to clean. The 45-4545-Lite profile is compatible with all 45 series fasteners. This light profile lends itself to clean room applications, guards, enclosures, or workstations. The four open T-slots enable access from any direction and are useful for mounting accessories.

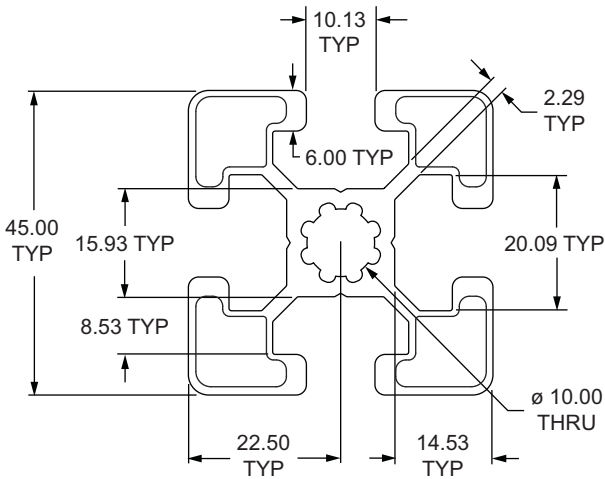

Part No.	Series	Stock Length	Material	Alloy**	Finish	Drop Lock	Moment of Inertia	Surface Area	Yield Strength	Modulus of Elasticity	Weight
45-4545-Lite *	45	4 or 6 Meter	Aluminum	6105-T5	Clear Anodize	None	IX = 9.2029 cm ⁴ IY = 9.2029 cm ⁴	5.167 cm ²	241.1 N / mm ²	70,326.5 N / mm ²	1.3976 kg / m
45-4545-Lite-Black-FB		per millimeter			Black Anodize						

* The above profiles are sold per millimeter or stock length.

** Or comparable

Standard Machining Services

Service No.	Series	Service Description	Reference Page
45-7010	45	Cut to Length	851
45-7248	45	Access Hole	855
45-7053	45	Tap Profile End	857
45-7037	45	Bolt Connector	872
45-7058	45	Central Connector	870

45-4545 Profile

45-4545 is a 45mm x 45mm metric 45 series square T-slot profile with four open T-slots, one on each 45mm face. The profile is smooth, which makes it resistant to dirt and debris buildup while also being easy to clean. The 45-4545 profile is compatible with all 45 series fasteners. This profile lends itself to clean room applications, guards, enclosures, or work stations. The four open T-slots enable access from any direction and are useful for mounting accessories.

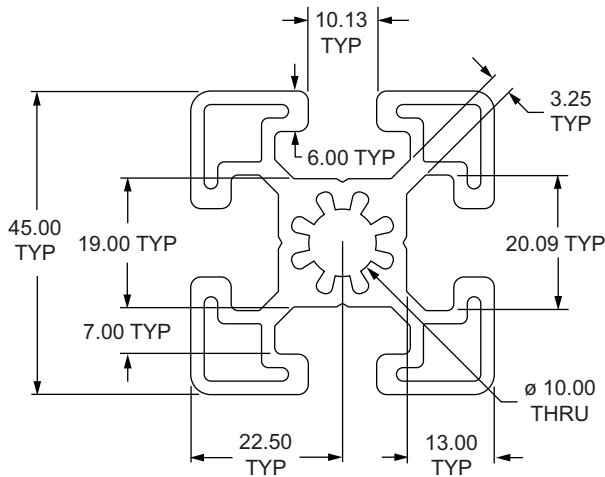

Part No.	Series	Stock Length	Material	Alloy**	Finish	Drop Lock	Moment of Inertia	Surface Area	Yield Strength	Modulus of Elasticity	Weight
45-4545*	45	4 or 6 Meter	Aluminum	6105-T5	Clear Anodize	None	IX = 13.9604 cm ⁴ IY = 13.9604 cm ⁴	7.587 cm ²	241.1 N / mm ²	70,326.5 N / mm ²	2.0455 kg / m
45-4545-Black-FB		per millimeter			Black Anodize						

* The above profiles are sold per millimeter or stock length.

** Or comparable

Standard Machining Services

Service No.	Series	Service Description	Reference Page
45-7010	45	Cut to Length	851
45-7248	45	Access Hole	855
45-7053	45	Tap Profile End	857
45-7037	45	Bolt Connector	872
45-7058	45	Central Connector	870

45mm X 90mm T-Slotted Profile - Six Open T-Slots

45-4590 Profile

45-4590 is a 45mm x 90mm metric 45 series rectangular T-slot profile with six open T-slots, two on each 90mm face and one on each 45mm face. The profile is smooth, which makes it resistant to dirt and debris buildup while also being easy to clean. The 45-4590 profile is compatible with 45 series fasteners. This profile lends itself to work spaces, machine guards, and displays. The six open T-slots enable access from any direction and are useful for mounting accessories.

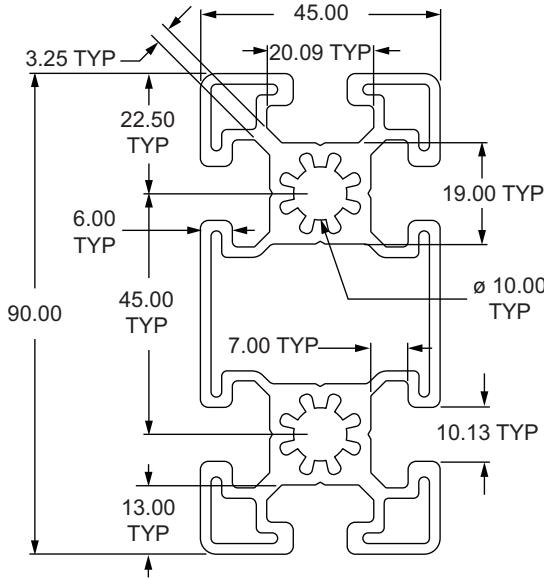

Part No.	Series	Stock Length	Material	Alloy**	Finish	Drop Lock	Moment of Inertia	Surface Area	Yield Strength	Modulus of Elasticity	Weight
45-4590 *	45	4 or 6 Meter	Aluminum	6105-T5	Clear Anodize	None	IX = 104.2072 cm ⁴ IY = 25.2637 cm ⁴	12.615 cm ²	241.1 N / mm ²	70,326.5 N / mm ²	3.4109 kg / m
45-4590-Black-FB		per millimeter			Black Anodize						

* The above profiles are sold per millimeter or stock length.

** Or comparable

Standard Machining Services

Service No.	Series	Service Description	Reference Page
45-7020	45	Cut to Length	851
45-7248	45	Access Hole	855
45-7032	45	Tap Profile End	854
45-7037	45	Bolt Connector	872

45-9090 Profile

45-9090 is a 90mm x 90mm metric 45 series square T-slot profile with eight open T-slots, two on each 90mm face. The profile is smooth, which makes it resistant to dirt and debris buildup while also being easy to clean. The 45-9090 profile is compatible with 45 series fasteners. The eight open T-slots and strength make it a great choice for automation applications, machine frames and workstations.

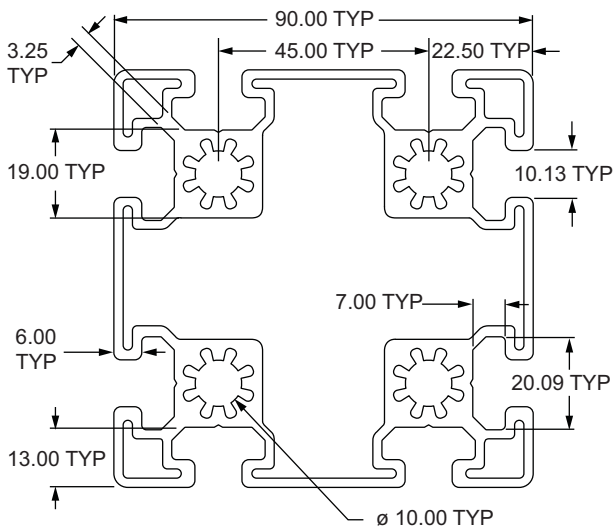

Part No.	Series	Stock Length	Material	Alloy**	Finish	Drop Lock	Moment of Inertia	Surface Area	Yield Strength	Modulus of Elasticity	Weight
45-9090 *	45	4 or 6 Meter	Aluminum	6105-T5	Clear Anodize	None	IX = 178.4968 cm ⁴ IY = 179.4968 cm ⁴	20.014 cm ²	241.1 N / mm ²	70,326.5 N / mm ²	5.4116 kg / m
45-9090-Black-FB		per millimeter			Black Anodize						

* The above profiles are sold per millimeter or stock length.

** Or comparable

Standard Machining Services

Service No.	Series	Service Description	Reference Page
45-7030	45	Cut to Length	851
45-7036	45	Tap Profile End	854
45-7037	45	Bolt Connector	872

1.50" X 1.50" Square Tube Profile - No Pre-Drilled Holes

9700 Profile

9700 is a 1.50" x 1.50" square Ready Tube profile with no pre-drilled holes. This profile lends itself to applications where you need an aesthetic look and clean, smooth surface such as framing, displays, trade show booths or retail kiosks.

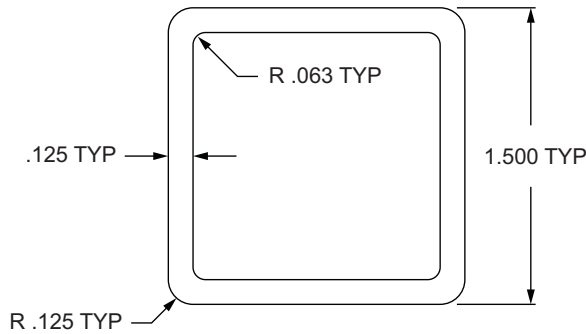

Part No.	Series	Stock Length	Material	Alloy**	Finish	Moment of Inertia	Surface Area	Yield Strength	Modulus of Elasticity	Weight
9700 *	RT	100" or 150"	Aluminum	6105-T5	Clear Anodize	IX = 0.2127 ⁱⁿ⁴ IY = 0.2127 ⁱⁿ⁴	0.6775 in. ²	35,000 psi	10,200,000 lb / in. ²	0.0660 lb / in.
9700-Black-FB		per inch			Black Anodize					

* The above profiles are sold per inch or stock length.

** Or comparable

Standard Machining Services

Service No.	Series	Service Description	Reference Page
7010	RT	Cut to Length	852
7246	RT	Clearance Drill Thru	864

9701 Profile

9701 is a 1.50" x 1.50" square Ready Tube profile with pre-drilled holes at 1.50" intervals along each face. The pre-drilled holes in this profile lend it to applications such as gravity racks, conveyor tables and material handling shelves.

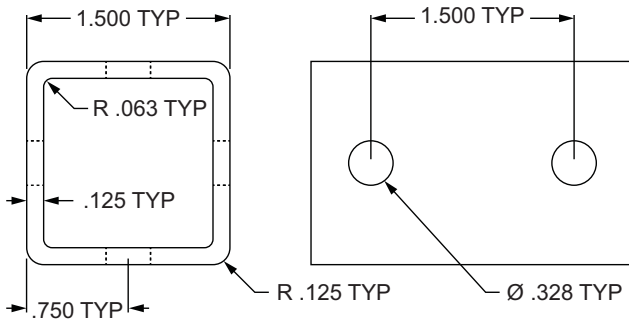

Part No.	Series	Stock Length	Material	Alloy**	Finish	Moment of Inertia	Surface Area	Yield Strength	Modulus of Elasticity	Weight
9701 *	RT	100" or 150"	Aluminum	6105-T5	Clear Anodize	—	0.6775 in. ²	35,000 psi	10,200,000 lb / in. ²	0.0660 lb / in.
9701-Black-FB		per inch			Black Anodize					

* The above profiles are sold per inch or stock length.

** Or comparable

Standard Machining Services

Service No.	Series	Service Description	Reference Page
7010	RT	Cut to Length	852
7246	RT	Clearance Drill Thru	864

1.50" X 1.50" P-Tube Profile - No Pre-Drilled Holes - Single 1.50" Flange on One Side

9705 Profile

9705 is a 1.50" x 1.50" P-shaped Ready Tube profile with no pre-drilled holes and a single 1.50" flange on one side. This profile lends itself to applications where you need an aesthetic look and clean, smooth surface such as framing, displays, trade show booths or retail kiosks.

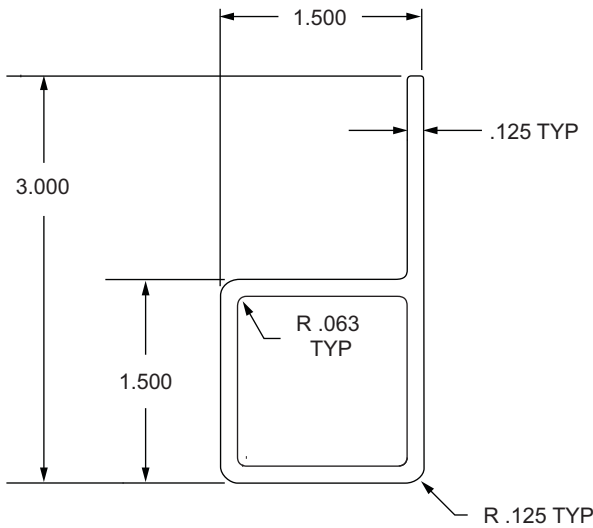

Part No.	Series	Stock Length	Material	Alloy**	Finish	Moment of Inertia	Surface Area	Yield Strength	Modulus of Elasticity	Weight
9705 *	RT	100" or 150"	Aluminum	6105-T5	Clear Anodize	—	0.8691 in. ²	35,000 psi	10,200,000 lb / in. ²	0.1033 lb / in.
9705-Black-FB		per inch			Black Anodize					

* The above profiles are sold per inch or stock length.

** Or comparable

Standard Machining Services

Service No.	Series	Service Description	Reference Page
7020	RT	Cut to Length	852
7246	RT	Clearance Drill Thru	864

1.50" X 1.50" P-Tube Profile - Pre-Drilled Holes - Single 1.50" Flange on One Side

9706 Profile

9706 is a 1.50" x 1.50" P-shaped Ready Tube profile with pre-drilled holes at 1.50" intervals and a single 1.50" flange on one side. The pre-drilled holes in this profile lend it to applications such as gravity racks, conveyor tables and material handling shelves.

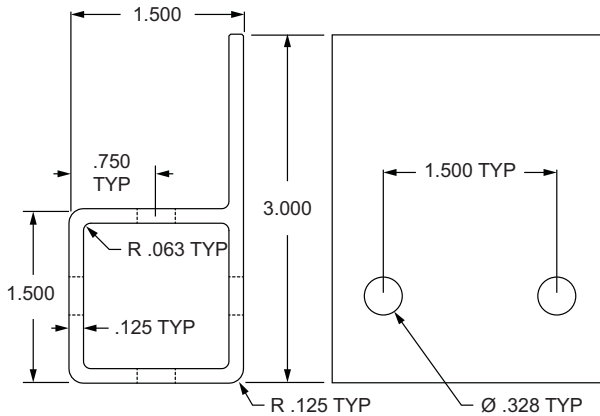

Part No.	Series	Stock Length	Material	Alloy**	Finish	Moment of Inertia	Surface Area	Yield Strength	Modulus of Elasticity	Weight
9706 *	RT	100" or 150"	Aluminum	6105-T5	Clear Anodize	—	0.8691 in. ²	35,000 psi	10,200,000 lb / in. ²	0.0848 lb / in.
9706-Black-FB		per inch			Black Anodize					

* The above profiles are sold per inch or stock length.

** Or comparable

Standard Machining Services

Service No.	Series	Service Description	Reference Page
7020	RT	Cut to Length	852
7246	RT	Clearance Drill Thru	864

1.50" X 1.50" A-Tube Profile - No Pre-Drilled Holes - Double 1.50" Flange on One Side

9725 Profile

9725 is a 1.50" x 1.50" A-shaped Ready Tube profile with a double 1.50" flange on one side and no pre-drilled holes. This profile lends itself to applications where you need an aesthetic appearance and clean, smooth surface such as framing, displays, material handling and do-it-yourself projects.

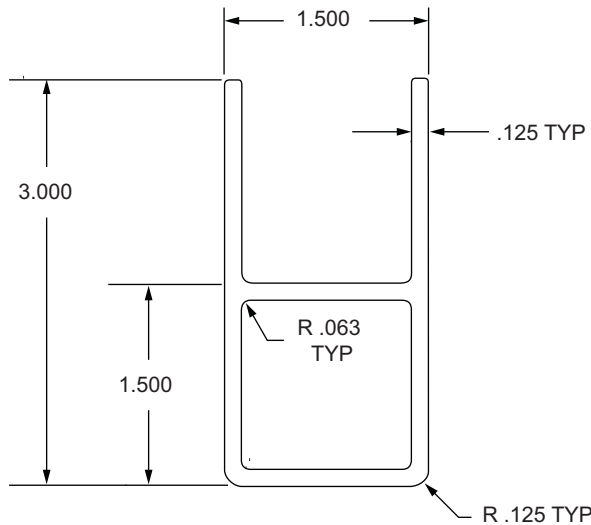

Part No.	Series	Stock Length	Material	Alloy**	Finish	Moment of Inertia	Surface Area	Yield Strength	Modulus of Elasticity	Weight
9725 *	RT	100" or 150"	Aluminum	6105-T5	Clear Anodize	—	1.061 in. ²	35,000 psi	10,200,000 lb / in. ²	0.1033 lb / in.
9725-Black-FB		per inch			Black Anodize					

* The above profiles are sold per inch or stock length.

** Or comparable

Standard Machining Services

Service No.	Series	Service Description	Reference Page
7020	RT	Cut to Length	852
7246	RT	Clearance Drill Thru	864

1.50" X 1.50" A-Tube Profile - Pre-Drilled Holes - Double 1.50" Flange on One Side

9726 Profile

9726 is a 1.50" x 1.50" A-shaped Ready Tube profile with a double 1.50" flange and pre-drilled holes at 1.50" intervals. The pre-drilled holes in this profile lend it to applications such as gravity racks, conveyor tables and material handling shelves.

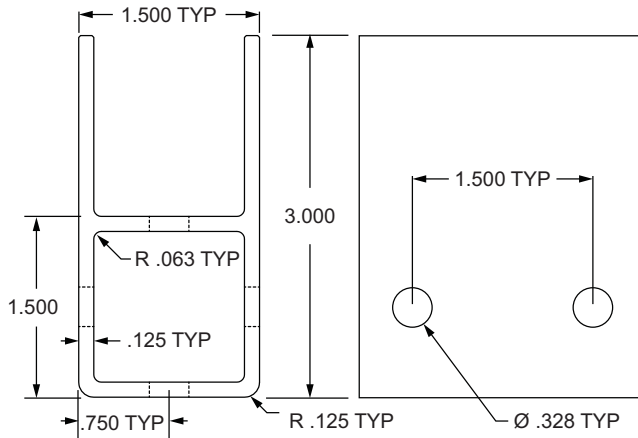

Part No.	Series	Stock Length	Material	Alloy**	Finish	Moment of Inertia	Surface Area	Yield Strength	Modulus of Elasticity	Weight
9726 *	RT	100" or 150"	Aluminum	6105-T5	Clear Anodize	—	1.061 in. ²	35,000 psi	10,200,000 lb / in. ²	0.1033 lb / in.
9726-Black-FB		per inch			Black Anodize					

* The above profiles are sold per inch or stock length.

** Or comparable

Standard Machining Services

Service No.	Series	Service Description	Reference Page
7020	RT	Cut to Length	852
7246	RT	Clearance Drill Thru	864

1.50" X 1.50" A-Tube Profile - Pre-Drilled Holes - Notches - Double 1.50" Flange on One Side

9728 Profile

9728 is a 1.50" x 1.50" A-shaped Ready Tube profile with two 1.50" adjacent flanges. Both flanges are notched and the tube has pre-drilled holes on 1.50" centerlines. The notches in this profile make it perfect for applications such as gravity racks, conveyor tables and material handling shelves.

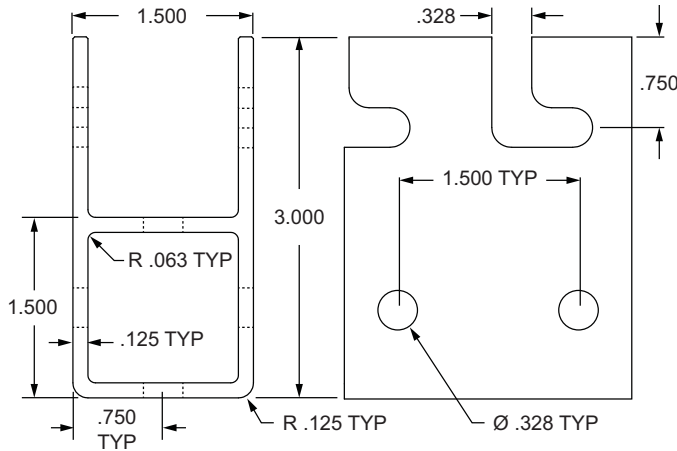

Part No.	Series	Stock Length	Material	Alloy**	Finish	Moment of Inertia	Surface Area	Yield Strength	Modulus of Elasticity	Weight
9728 *	RT	100" or 150"	Aluminum	6105-T5	Clear Anodize	—	1.061 in. ²	35,000 psi	10,200,000 lb / in. ²	0.1033 lb / in.
9728-Black-FB		per inch			Black Anodize					

* The above profiles are sold per inch or stock length.

** Or comparable

Standard Machining Services

Service No.	Series	Service Description	Reference Page
7020	RT	Cut to Length	852
7246	RT	Clearance Drill Thru	864

9000 Profile

9000 is a 1.00" x 1.00" square Quick Frame profile with a grooved interior used to hold nylon connectors into place. The profile has a smooth surface for a sleek appearance and allows for easy cleaning, lending itself to applications such as framing, displays, or retail kiosks.

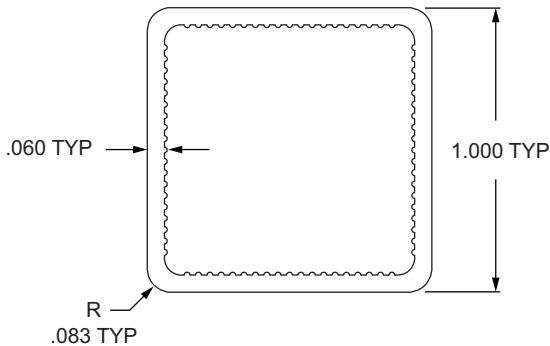

Part No.	Series	Stock Length	Material	Alloy**	Finish	Moment of Inertia	Surface Area	Yield Strength	Modulus of Elasticity	Weight
9000 *	QF	145"	Aluminum	6105-T5	Clear Anodize	—	.2228 in. ²	35,000 psi	10,200,000 lb / in. ²	0.0231 lb / in.
9000-Black-FB		per inch			Black Anodize					

* The above profiles are sold per inch or stock length.

** Or comparable

Standard Machining Services

Service No.	Series	Service Description	Reference Page
7310	QF	Cut to Length	852

1.00" X 1.00" Tube Profile - Single 0.5" Flange on One Side

9005 Profile

9005 is a 1.00" x 1.00" Quick Frame profile with a single 0.5" flange on one side and a grooved interior used to hold nylon connectors into place. The profile has a smooth surface for a sleek appearance and allows for easy cleaning, lending itself to applications such as framing, displays, or retail kiosks.

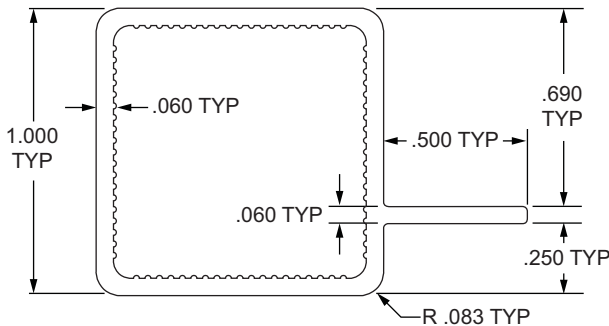

Part No.	Series	Stock Length	Material	Alloy**	Finish	Moment of Inertia	Surface Area	Yield Strength	Modulus of Elasticity	Weight
9005 *	QF	145"	Aluminum	6105-T5	Clear Anodize	—	.2528 in. ²	35,000 psi	10,200,000 lb / in. ²	0.0261 lb / in.
9005-Black-FB		per inch			Black Anodize					

* The above profiles are sold per inch or stock length.

** Or comparable

Standard Machining Services

Service No.	Series	Service Description	Reference Page
7310	QF	Cut to Length	852
7300	QF	45° Flange Milling	875

80/20® 1.00" X 1.00" Tube Profile - Single 0.5" Flanges on Adjacent Sides

9010 Profile

9010 is a 1.00" x 1.00" Quick Frame profile with two single 0.5" flanges on adjacent sides, and a grooved interior used to hold nylon connectors into place. The profile has a smooth surface for a sleek appearance, allows for easy cleaning and holds paneling in place, lending itself to applications such as framing, displays, or retail kiosks.

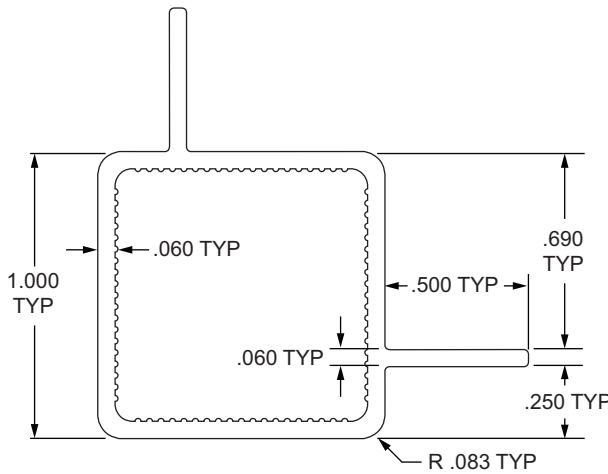

Part No.	Series	Stock Length	Material	Alloy**	Finish	Moment of Inertia	Surface Area	Yield Strength	Modulus of Elasticity	Weight
9010 *	QF	145"	Aluminum	6105-T5	Clear Anodize	—	.2828 in. ²	35,000 psi	10,200,000 lb / in. ²	0.0291 lb / in.
9010-Black-FB		per inch			Black Anodize					

* The above profiles are sold per inch or stock length.

** Or comparable

Standard Machining Services

Service No.	Series	Service Description	Reference Page
7310	QF	Cut to Length	852
7301	QF	45° Flange Milling	875

1.00" X 1.00" Tube Profile - Single 0.5" Flanges on Opposite Sides

9015 Profile

9015 is a 1.00" x 1.00" Quick Frame profile with two single 0.5" flanges on opposite sides, and a grooved interior used to hold nylon connectors into place. The profile has a smooth surface for a sleek appearance, allows for easy cleaning and holds paneling in place, lending itself to applications such as framing, displays, or retail kiosks.

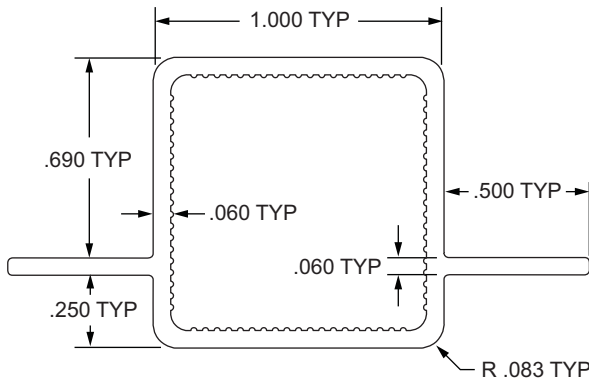

Part No.	Series	Stock Length	Material	Alloy**	Finish	Moment of Inertia	Surface Area	Yield Strength	Modulus of Elasticity	Weight
9015 *	QF	145"	Aluminum	6105-T5	Clear Anodize	—	.2828 in. ²	35,000 psi	10,200,000 lb / in. ²	0.0291 lb / in.
9015-Black-FB		per inch			Black Anodize					

* The above profiles are sold per inch or stock length.

** Or comparable

Standard Machining Services

Service No.	Series	Service Description	Reference Page
7310	QF	Cut to Length	852
7302	QF	45° Flange Milling	875

80/20® 1.00" X 1.00" Tube Profile - Double 0.5" Flanges on One Side

9025 Profile

9025 is a 1.00" x 1.00" Quick Frame profile with right angle double 0.5" twin flanges and a grooved interior used to hold nylon connectors into place. The profile has a smooth surface for a sleek appearance and allows for easy cleaning. The positioning of the twin flanges makes the profile perfect for light-weight applications requiring paneling such as enclosures, guarding, storage, and shelving solutions.

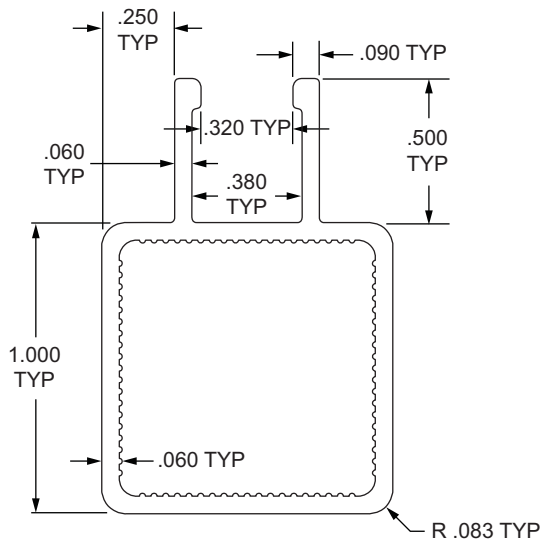

Part No.	Series	Stock Length	Material	Alloy**	Finish	Moment of Inertia	Surface Area	Yield Strength	Modulus of Elasticity	Weight
9025 *	QF	145"	Aluminum	6105-T5	Clear Anodize	—	.2889 in. ²	35,000 psi	10,200,000 lb / in. ²	0.0296 lb / in.
9025-Black-FB		per inch			Black Anodize					

* The above profiles are sold per inch or stock length.

** Or comparable

Standard Machining Services

Service No.	Series	Service Description	Reference Page
7310	QF	Cut to Length	852
7300	QF	45° Flange Milling	875

1.00" X 1.00" Tube Profile - Double 0.5" Flanges on Adjacent Sides

9030 Profile

9030 is a 1.00" x 1.00" Quick Frame profile with right angle double 0.5" twin flanges. The profile has a smooth surface for a sleek appearance and allows for easy cleaning. The positioning of the twin flanges makes the profile perfect for light-weight applications requiring paneling such as enclosures, guarding, storage, and shelving solutions.

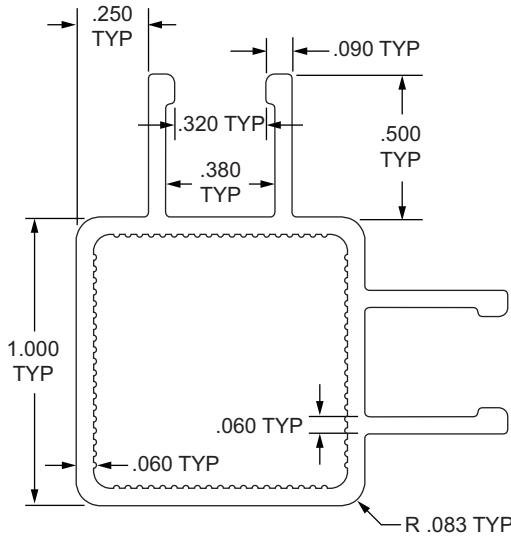

Part No.	Series	Stock Length	Material	Alloy**	Finish	Moment of Inertia	Surface Area	Yield Strength	Modulus of Elasticity	Weight
9030 *	QF	145"	Aluminum	6105-T5	Clear Anodize	—	.3550 in. ²	35,000 psi	10,200,000 lb / in. ²	0.0362 lb / in.
9030-Black-FB		per inch			Black Anodize					

* The above profiles are sold per inch or stock length.

** Or comparable

Standard Machining Services

Service No.	Series	Service Description	Reference Page
7310	QF	Cut to Length	852
7301	QF	45° Flange Milling	875

80/20® 1.00" X 1.00" Tube Profile - Double 0.5" Flanges on Opposite Sides

9035 Profile

9035 is a 1.00" x 1.00" Quick Frame profile with 0.5" double twin flanges on opposite sides and a grooved interior used to hold nylon connectors into place. The profile has a smooth surface for a sleek appearance and allows for easy cleaning. The positioning of the twin flanges makes the profile perfect for light-weight applications requiring paneling such as enclosures, guarding, storage, and shelving solutions.

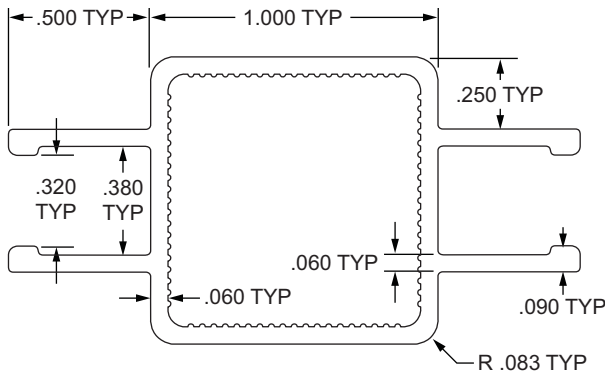

Part No.	Series	Stock Length	Material	Alloy**	Finish	Moment of Inertia	Surface Area	Yield Strength	Modulus of Elasticity	Weight
9035 *	QF	145"	Aluminum	6105-T5	Clear Anodize	—	.3550 in. ²	35,000 psi	10,200,000 lb / in. ²	0.0362 lb / in.
9035-Black-FB		per inch			Black Anodize					

* The above profiles are sold per inch or stock length.

** Or comparable

Standard Machining Services

Service No.	Series	Service Description	Reference Page
7310	QF	Cut to Length	852
7302	QF	45° Flange Milling	875

80/20 **IN** Action

Look Close: Our Products Are Everywhere

You'll find that once you start looking around you'll see 80/20 products everywhere! From machine guards to displays, 80/20 is a product for individuals, industries and businesses alike.

- Workstations
- Safety & Guarding
- Material Handling
- Displays
- MRO



Displays



Workstations

Better Quality Greater Efficiencies Increased Productivity

Businesses find that the T-slot system leads to decreased waste and custom solutions. You can find 80/20 in industries such as:

- Automation
- Pneumatics
- Industrial Manufacturing
- Molding & Plastics
- Healthcare
- Automotive
- Arts & Entertainment
- Architecture
- Robotics
- Research & Development
- Universities
- Retail



Architecture



Healthcare



Robotics

PROFILES

Pictorial Table Of Contents



Introduction to Fastening Methods



Page 204

Fastening Method Types

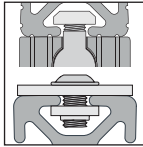

Page 205

Get to Know Your Hardware



Page 206

T-Nut Types



Page 207

Hardware Options



Page 208

Ready Tube Connectors



Page 209

Quick Frame Connectors

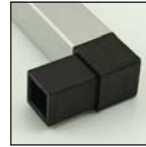

Page 210

Internal Fastening Methods

Standard Anchor Fastener



Page 212

Standard Anchor Fastener Cam



Page 213

Short Double Anchor Fastener



Page 214

Long Double Anchor Fastener



Page 215

Butt Fastener



Page 216

Standard End Fastener



Page 217

Single Tab End Fastener



Page 218

Double End Fastener



Page 219

Hidden Corner Connector



Page 220

Miter Connector



Page 221

90 Degree Inside Corner Connector



Page 222

Central Connector



Page 223

Bolt Connector



Page 224

External Fastening Methods

Plate Connector



Page 225

45 Degree Support Connector



Page 226

45 Degree Supports



Page 227

2 Hole Straight Flat Plate



Page 233

3 Hole Straight Flat Plate



Page 234

4 Hole Straight Flat Plate



Page 235

4 Hole Square Flat Plate



Page 236

6 Hole Rectangular Flat Plate



Page 237

8 Hole Rectangular Flat Plate



Page 238

2 Hole Straight Transition Plate



Page 239

2 Hole Straight Transition Plate with Flush Offset



Page 240

2 Hole Slotted Transition Plate with Flush Offset



Page 241

3 Hole Straight Transition Plate Small Series Primary



Page 242

3 Hole Straight Transition Plate Large Series Primary



Page 243

CONTINUE



Pictorial Table Of Contents

4 Hole Straight Transition Plates



Page 244

4 Hole Rectangular Transition Plates



Page 245

4 Hole Rectangular Transition Plates with Flush Offset



Page 246

4 Hole Rectangular Slotted Transition Plates w/ Flush Offset



Page 247

6 Hole Rectangular Transition Plates Small Series Primary



Page 248

6 Hole Rectangular Transition Plates Large Series Primary



Page 249

8 Hole Rectangular Transition Plates



Page 250

4 Hole 90 Degree Angled Flat Plates



Page 251

5 Hole 90 Degree Angled Flat Plates



Page 252

6 Hole 90 Degree Angled Stacked Flat Plates



Page 253

6 Hole 90 Degree Angled Squared Flat Plates



Page 254

7 Hole 90 Degree Angled Squared Flat Plates



Page 255

7 Hole 90 Degree Angled Stacked Flat Plates



Page 256

9 Hole 90 Degree Angled Flat Plates



Page 257

10 Hole 90 Degree Angled Flat Plates



Page 258

12 Hole 90 Degree Angled Flat Plates



Page 259

4 Hole 15 Degree Angled Flat Plates



Page 260

6 Hole 15 Degree Angled Flat Plates



Page 261

4 Hole 30 Degree Angled Flat Plates



Page 262

6 Hole 30 Degree Angled Flat Plates



Page 263

4 Hole 45 Degree Angled Flat Plates



Page 264

6 Hole 45 Degree Angled Flat Plates



Page 265

4 Hole 60 Degree Angled Flat Plates



Page 266

6 Hole 60 Degree Angled Flat Plates



Page 267

4 Hole Tee Flat Plate



Page 268

5 Hole Tee Flat Plate



Page 269

6 Hole Tee Flat Plate



Page 270

7 Hole Tee Flat Plate



Page 271

8 Hole Tee Flat Plate



Page 272

11 Hole Tee Flat Plate



Page 273

12 Hole Tee Flat Plate



Page 274

16 Hole Tee Flat Plate



Page 275

7 Hole Cross Flat Plate



Page 276

12 Hole Cross Flat Plate



Page 277

16 Hole Cross Flat Plate



Page 278

CONTINUE

Pictorial Table Of Contents



<p>20 Hole Cross Flat Plate</p>  <p>Page 279</p>	<p>5 Hole "L" Flat Plate</p>  <p>Page 280</p>	<p>5 Hole "T" Flat Plate</p>  <p>Page 281</p>	<p>2 Hole Lite Inside Corner Bracket</p>  <p>Page 282</p>	<p>2 Hole Inside Corner Bracket</p>  <p>Page 283</p>	<p>2 Hole Slotted Inside Corner Bracket</p>  <p>Page 284</p>	<p>2 Hole Inside Corner Bracket with Single Support</p>  <p>Page 285</p>
<p>2 Hole 18mm Slotted Bracket with Dual Support</p>  <p>Page 286</p>	<p>2 Hole 20mm Slotted Bracket with Dual Support</p>  <p>Page 287</p>	<p>2 Hole 27mm Slotted Bracket with Dual Support</p>  <p>Page 288</p>	<p>2 Hole 28mm Slotted Bracket with Dual Support</p>  <p>Page 289</p>	<p>2 Hole 39mm Slotted Bracket with Dual Support</p>  <p>Page 290</p>	<p>2 Hole 42mm Slotted Bracket with Dual Support</p>  <p>Page 291</p>	<p>3 Hole Inside Corner Bracket</p>  <p>Page 292</p>
<p>3 Hole Slotted Inside Corner Bracket</p>  <p>Page 293</p>	<p>4 Hole Wide Inside Corner Bracket</p>  <p>Page 294</p>	<p>4 Hole Tall Inside Corner Bracket</p>  <p>Page 295</p>	<p>4 Hole Inside Corner Bracket with Single Support</p>  <p>Page 296</p>	<p>4 Hole Inside Corner Bracket with Dual Support</p>  <p>Page 297</p>	<p>4 Hole Tall Lite Inside Corner Bracket</p>  <p>Page 298</p>	<p>4 Hole Wide Slotted Inside Corner Bracket</p>  <p>Page 299</p>
<p>6 Hole Tall Inside Corner Bracket</p>  <p>Page 300</p>	<p>6 Hole Wide 2x4 Corner Bracket</p>  <p>Page 301</p>	<p>6 Hole Wide 2x4 Slotted Bracket</p>  <p>Page 302</p>	<p>6 Hole Wide 3x3 Corner Bracket</p>  <p>Page 303</p>	<p>6 Hole Center Corner Bracket</p>  <p>Page 304</p>	<p>6 Hole Left Aligned Corner Bracket</p>  <p>Page 305</p>	<p>6 Hole Right Aligned Corner Bracket</p>  <p>Page 306</p>
<p>6 Hole Wide Slotted Inside Corner Bracket</p>  <p>Page 307</p>	<p>8 Hole Inside Corner Bracket</p>  <p>Page 308</p>	<p>8 Hole 57mm Bracket with Dual Support</p>  <p>Page 309</p>	<p>8 Hole 76mm Bracket with Dual Support</p>  <p>Page 310</p>	<p>8 Hole 86mm Bracket with Dual Support</p>  <p>Page 311</p>	<p>9 Hole Wide Slotted Inside Corner Bracket</p>  <p>Page 312</p>	<p>10 Hole Inside Corner Bracket</p>  <p>Page 313</p>

CONTINUE 



Pictorial Table Of Contents

12 Hole Tall Inside Corner Bracket



Page 314

12 Hole Wide Inside Corner Bracket



Page 315

18 Hole Inside Corner Bracket



Page 316

3 Way Triangular Corner Bracket



Page 317

3 Way Rounded Corner Bracket



Page 318

2 Hole Lite Transition Inside Corner Bracket



Page 319

2 Hole Transition Inside Corner Bracket



Page 320

4 Hole Tall Transition Inside Corner Bracket



Page 321

4 Hole Lite Wide Transition Inside Corner Bracket



Page 322

4 Hole Wide Transition Inside Corner Bracket



Page 323

8 Hole Center Transition Inside Corner Bracket



Page 324

2 Hole Gusseted Inside Corner Bracket



Page 325

4 Hole Tall Gusseted Inside Corner Bracket



Page 326

4 Hole Wide Gusseted Inside Corner Bracket



Page 327

8 Hole Gusseted Inside Corner Bracket



Page 328

3 Way Squared Corner Connector



Page 329

2 Way Light Squared Corner Connector



Page 330

3 Way Light Squared Corner Connector



Page 331

3 Way Rounded Corner Connector



Page 332

3 Way Triangular Corner Connector



Page 333

Variable Angle Connectors

Standard Angle Clamp Block



Page 334

Economy Angle Clamp Block



Page 335

2 Hole Pivot Joint



Page 336

3 Hole Triangular Pivot Plate



Page 338

3 Hole Recessed Straight Pivot Plate



Page 339

3 Hole Recessed Triangular Pivot Plate



Page 340

5 Hole Triangular Pivot Plate



Page 341

5 Hole Recessed Triangular Pivot Plate



Page 342

0 Degree Structural Pivot Nub



Page 343

90 Degree Structural Pivot Nub



Page 344

Universal Structural Pivot Nub



Page 345

0 Degree Structural Right Angle Pivot Nub



Page 346

90 Degree Structural Right Angle Pivot Nub



Page 347

Universal Structural Right Angle Pivot Nub



Page 348

CONTINUE

Pictorial Table Of Contents



"L" Structural
Pivot Arm



Page 349

Standard Straight
Structural
Pivot Arm



Page 350

Extended Straight
Structural Pivot Arm



Page 351

Standard Structural
Pivot Assembly with
Dual Straight Arms



Page 352

Standard Structural
Pivot Assembly with
Dual "L" Arms



Page 354

Standard Structural
Pivot Assembly with
Straight and "L" Arm



Page 356

Right Angle Structural
Pivot Assembly with
Dual Straight Arms



Page 358

Right Angle Structural
Pivot Assembly with
Dual "L" Arms



Page 360

Hardware

Slide-in Economy
T-Nut Center Thread



Page 362

Slide-in Economy
T-Nut Offset Thread



Page 363

Double Slide-in
Economy T-Nut



Page 364

Triple Slide-in
Economy T-Nut



Page 365

Standard
Slide-in T-Nut



Page 366

Self-Aligning
Slide-in T-Nut with
Ball Spring



Page 368

Slide-in T-Nut
with Ball Spring



Page 369

Self-Aligning
Slide-in T-Nut



Page 370

Slide-in Economy
T-Nut Block



Page 371

Roll-in T-Nut with
Flex Handle



Page 372

Roll-in T-Nut
with Set Screw



Page 373

Roll-in T-Nut
with Ball Spring



Page 374

Self-Aligning
Roll-in T-Nut with
Ball Spring



Page 375

Self-Aligning
Roll-in T-Nut



Page 376

Tall Self-Aligning
Roll-in T-Nut with
Spring Leaf



Page 377

Short Self-Aligning
Roll-in T-Nut with
Spring Leaf



Page 378

Economy
Drop-in T-Nut



Page 379

Standard
Drop-in T-Nut



Page 380

Slide-in T-Nut with
Holding Spring



Page 382

Double Anchor
Slide-in T-Nut



Page 383

Nylon T-Slot Nut



Page 384

CONTINUE



Pictorial Table Of Contents

Button Head
Socket Cap Screw



Page 385

Flanged Button Head
Socket Cap Screw



Page 387

Flat Head Socket
Cap Screw



Page 388

Socket Head
Cap Screw



Page 389

Low Head Socket
Cap Screw



Page 393

Flanged Hex
Head Bolt



Page 393

Connecting Screw



Page 394

Self Tapping
Screw



Page 394

Self Drilling
Screw



Page 394

Threaded Insert



Page 395

Bearing Pad
Screw



Page 395

Shoulder Bolt



Page 396

Shoulder Bolt
Assembly



Page 396

Washer



Page 397

Hex Nut



Page 398

Flanged Hex
Head Nut



Page 399

Slide-in Flanged
Economy T-Slot Stud



Page 400

Drop-in T-Slot
Stud Assembly



Page 401

Drop-in T-Slot
Stud



Page 402

Drop-in T-Slot Stud
with Flanged Hex Nut



Page 403

Slide-in Economy
T-Slot Stud



Page 404

Ready Tube[™] Connectors

Standard
Tube Insert



Page 417

Extended
Tube Insert



Page 418

Standard Tube Insert
Kit with Hex Nut



Page 419

Standard Tube Insert
Kit with Roll Pin



Page 420

Roll Pin



Page 421

Anti-Rotation Plate





















Page 422

CONTINUE

Pictorial Table Of Contents



Quick Frame[™] Connectors

<p>2 Way Butt Connector</p>  <p>Page 423</p>	<p>2 Way Corner Connector</p>  <p>Page 424</p>	<p>90 Degree Straight Base Connector</p>  <p>Page 425</p>	<p>90 Degree Corner Base Connector</p>  <p>Page 426</p>	<p>3 Way Tee Connector</p>  <p>Page 427</p>	<p>3 Way Corner Connector</p>  <p>Page 428</p>	<p>4 Way Cross Connector</p>  <p>Page 429</p>	
<p>4 Way Corner Connector</p>  <p>Page 430</p>	<p>5 Way Junction Connector</p>  <p>Page 431</p>	<p>6 Way Junction Connector</p>  <p>Page 432</p>	<p>Caster or Spacer Receptacle Insert</p>  <p>Page 433</p>	<p>3 Way Connector with Caster or Spacer Receptacle</p>  <p>Page 434</p>	<p>2 Way Spacer</p>  <p>Page 435</p>	<p>3 Way Hexagon Segment Connector</p>  <p>Page 436</p>	
<p>30 Degree Straight Hexagon Base Connector</p>  <p>Page 437</p>	<p>60 Degree Hexagon Side and Top Connector</p>  <p>Page 438</p>	<p>20 Degree Pitch Hexagon Connector</p>  <p>Page 439</p>	<p>Quick Frame to 10 Series Transition Tee</p>  <p>Page 440</p>				

Introduction to Fastening Methods

There are several options when choosing your fastening method. The intent of this section is to give an overview of points to consider as well as a brief summary of fastening options. While the variety may seem overwhelming, you can narrow down your selection based on properties of your desired fastener.

Keep in mind that in most instances, there is no "one right way" or "one right answer" when choosing your method. It will depend on personal preference, circumstance, application, design and purpose.

Internal Fasteners

Anchor Fastener



End Fastener



Central Connector



Hidden Corner Connector



45 Degree Supports



Structural Pivots



Flat Plates



Brackets & Gussets

External Fasteners

Fastening Method Types

As a way to simplify your decision-making process, it's easiest to categorize fasteners into two main groups: internal fasteners and external fasteners. Most of the fastening connections offered by 80/20 fall into one of these two groups and each group has unique attributes and properties.

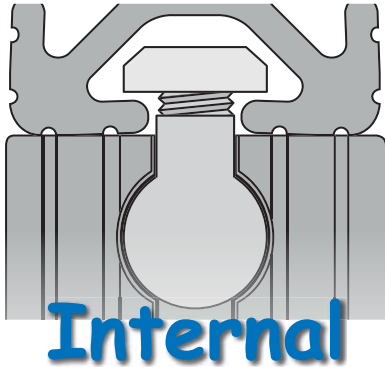

Internal connections create strong bonds between profiles because in most cases the fastener is machined into the profile. They are easy to assemble, require few parts and are simple to work into your design.

INTERNAL BENEFITS

- Fastener recessed in T-slot
- Fewer parts
- Easy to assemble
- Easy to incorporate
- Hardware typically included
- Hidden connections available
- Options for infinite positioning
- Typically will not affect design area



External connections mount to the outside of the T-slot, strengthen connection points, and are easy to implement into the application. Most external connections are reconfigurable and can be mounted anywhere along the T-slot.

EXTERNAL BENEFITS

- Mount to T-slot
- Usually no machining required
- Options for infinite positioning
- Easy to implement
- Reconfigurable connections
- Ability for variable angles
- Strengthen connection points
- Assemble with simple hardware
- Options for connecting more than two profiles

Visit Online for More

For more information on 80/20 fasteners visit www.8020.net to view the Fastener Application Test.



Get to Know Your Hardware								
Part	Part Image	No Machining	Hardware Included	Reconfigurable	Flush	More Than 2-Way Hub	Hidden	Infinite Positioning
<i>Internal</i>								
Anchor Fastener			✓	✓	✓			✓
End Fastener			✓		✓	✓	✓	
Inside Corner Connector		✓	✓					✓
Hidden Corner Connector		✓	✓		✓		✓	✓
Butt Fastener			✓		✓			
Miter Connector			✓		✓			
<i>External</i>								
Flat Plates		✓		✓				✓
Brackets and Gussets		✓		✓		✓		✓
3-Way Corner Connectors					✓	✓		
45 Degree Supports		✓	✓		✓			
Pivot Hinge Assemblies		✓		✓				✓

T-Nut Types

80/20 offers a wide variety of hardware with options in size, material, shape, thread alignment, and installation method. Three popular types of T-nuts are slide-in, drop-in, and roll-in.

Drop-In T-Nut

Drop-in T-nuts load from anywhere on the profile, making them perfect in instances where the ends of the profiles are captivated and you want to add to your application without dismantling the frame.

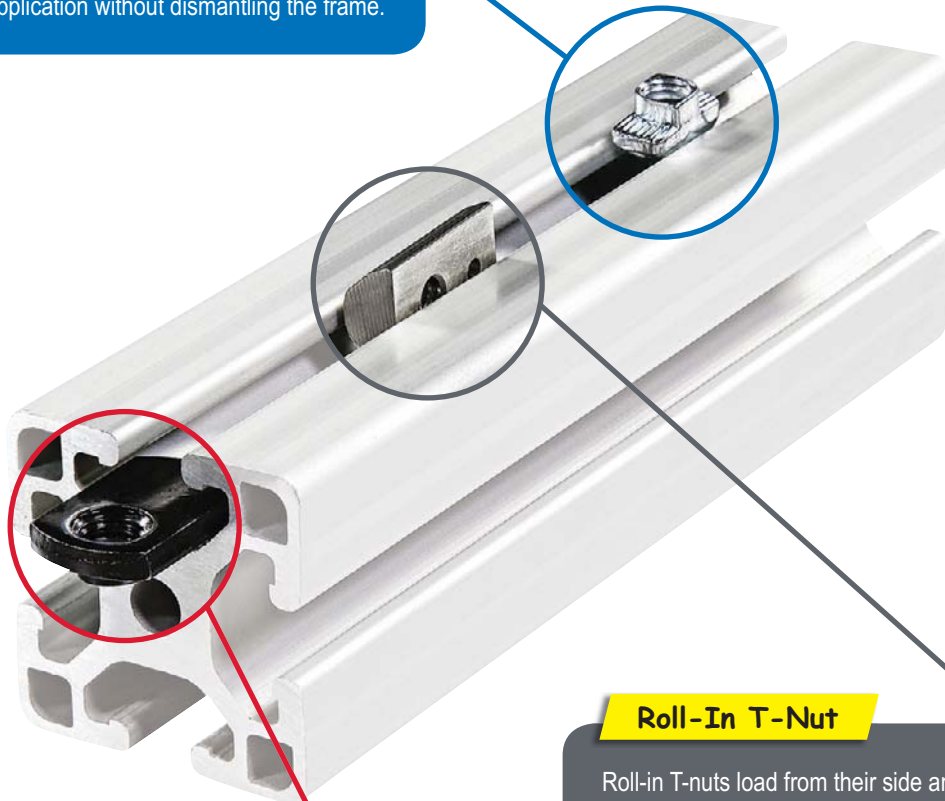

Slide-In T-Nut

Slide-in T-nuts load from the end of the profile and are available in several configurations including a centered or offset thread, and material and finish options.

Roll-In T-Nut

Roll-in T-nuts load from their side and spin into place, which allows for infinite positioning along the T-slot. They can be used even when profiles are captivated. Roll-in T-nuts come in several variations, including self-aligning options as well as features to hold the T-nut in place for easy positioning.

Hardware Options

80/20 offers a wide variety of bolt fastening options. Some of the most frequently used are Button Head, Socket Head, Flanged Button Head, Flat Head and Low Head.

Button Head (BHSCS)

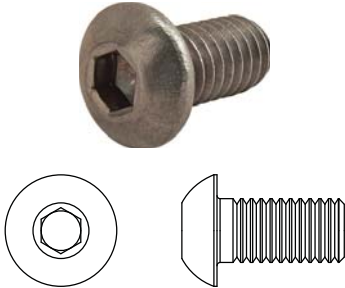

Socket Head (SHCS)



Flanged Button Head (FBHSCS)

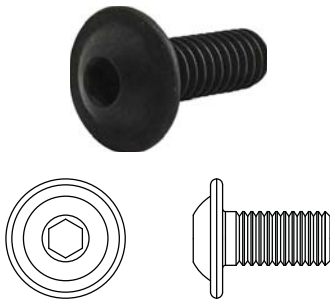

Flat Head (FHSCS)

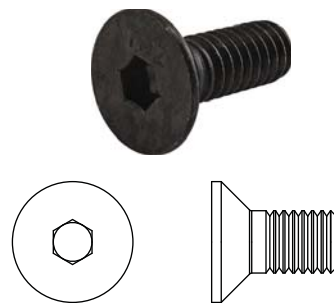

Low Head (LHSCS)



Need to Know

Possible hardware materials include: Black Zinc, Bright Zinc, Blue Zinc and Stainless Steel.

Ready Tube[™] Fasteners 101

80/20 offers several fastening options for Ready Tube profiles. While the most common is the Ready Connector Kit, there are also additional internal and external connection methods. Because Ready Tube profiles have pre-drilled holes, the connection methods do not require machining.



Only need a wrench!

Ready Tube Connects in 4 Steps

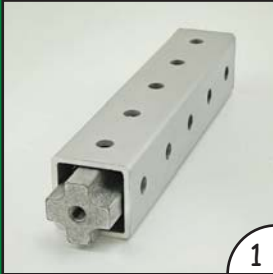

1



2



3



4

Standard Insert Kit



The Standard Tube Insert Kit includes all of the hardware you will need to easily assemble your project. This method is used for 90 degree connections when the end of the mounting profile is exactly .750" of an inch from the first hole centerline.

Extended Insert Kit



The Extended Tube Insert Kit also includes all of the hardware you will need to easily assemble your project. This kit is used in instances when the end of the mounting profile is not exactly .750" of an inch from the first hole centerline.

Roll Pin



The roll pin is commonly used with the standard tube insert and is an internal connection method for Ready Tube. It provides a smooth, clean finish and eliminates the need for protruding hardware when used with Ready Tube connector kits.

Compatible with Additional 15 Series Fasteners

80/20 corner brackets, gussets, and flat plates can also be used to make connections between Ready Tube profiles. All of these connection methods are external, meaning that they are easy to use, reconfigurable, and mount directly to the profile.



Quick Frame™ Fasteners 101

80/20 Quick Frame connectors are made of black or gray nylon and used with a Quick Frame Profile which has built-in ridges that bite into the fastener to create tension without the use of additional hardware. The profiles connect quickly and easily using only a soft-faced mallet to form light-duty yet sturdy builds.

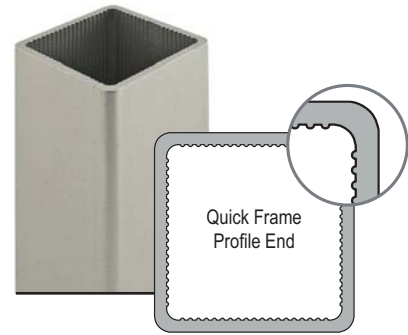

Quick Frame Connects in 4 Steps

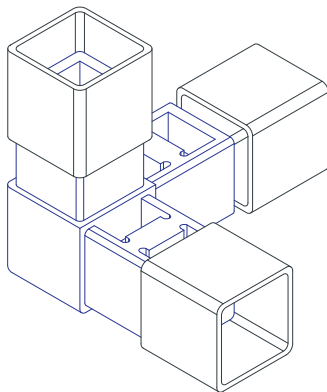
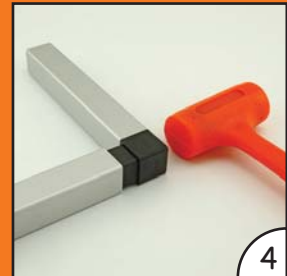
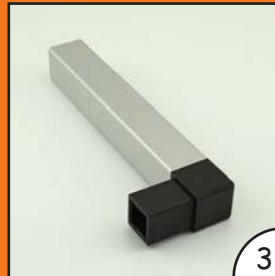

No Machining, No Additional Hardware



80/20 Quick Frame connectors require no machining or additional hardware for assembly. This fast and efficient method is perfect for lightweight and cost-effective applications that still require a sturdy and secure connection. Quick Frame connectors also do not degrade and can even be submerged in water without deteriorating.

Variety of Fastening Options

80/20 has a variety of Quick Frame fastening options that enable connections between multiple profiles (up to eight using just one connector) as well as options to join profiles at varying angles. 80/20 also offers base connectors for projects that will be attached or mounted to any flat surface or T-slot profile. Use a soft faced mallet to install Quick Frame connectors (see page 906).



80/20[®] Inc. **Xtreme** DIY

Do-It-Yourself Solutions

80/20's Xtreme[®] DIY series is a compilation of projects that businesses or the home-hobbyist can customize and alter to fit specific needs and requirements. These are designed to get your creativity flowing as well as highlight the diverse and unique ways 80/20 aluminum T-slot profiles and parts provide solutions.

Xtreme Ideas

- In the Home
- For the Garage or Shop
- At the Workplace
- Support Hobbyists

Visit our YouTube channel to view all the Xtreme DIY solutions and catch new 80/20 videos.

You Tube[™]

 **Subscribe**

Standard Anchor Fastener

80/20[®] Inc.

Part Description:

The standard anchor fastener assembly is comprised of a socket head cap screw, cam, and T-nut. It is one of the strongest internal fastening methods, offering a long-lasting connection. The anchor fastener provides infinite positioning along the mating profile's T-slot, allowing a large degree of adjustability. The anchor fastener provides 90 degree, flush, vibration resistant connections, especially convenient where space restrictions apply. This connection method requires a counterbore machining service on the mounting profile. **Additional Information:** Cams are available separately (without the socket head cap screw and T-nut) for instances where you want to create your own custom assembly.

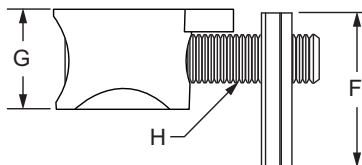
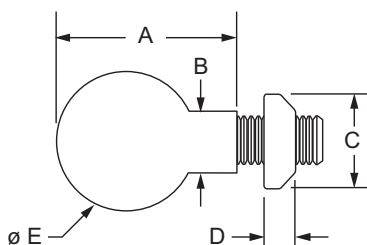

Part No.	Series	T-Nut	Cam Color	A	B	C	D	E	F	G	H	Weight
3395	10	Standard Slide-in	Bright	.730"	.245"	.431"	.171"	.562"	.490"	.406"	10-32 x .75" SHCS	.031 lb
3896	10	Standard Slide-in	Bright	.730"	.245"	.431"	.171"	.562"	.490"	.406"	M5 x 18mm SHCS	.031 lb
3665*	10	Economy Slide-in	Black	.730"	.245"	.380"	.124"	.562"	.625"	.406"	10-32 x .75" SHCS	.030 lb
3392	10	Standard Slide-in	Black	.730"	.245"	.431"	.171"	.562"	.490"	.406"	10-32 x .75" SHCS	.031 lb
3363	10	Roll-in w/ Flex Handle	Bright	.730"	.245"	.395"	.200"	.562"	.620"	.406"	10-32 x .75" SHCS	.031 lb
3360	15	Standard Slide-in	Bright	1.383"	.309"	.625"	.250"	.810"	.700"	.625"	5/16-18 x 1.30" SHCS	.101 lb
3897	15	Standard Slide-in	Bright	1.383"	.309"	.625"	.250"	.810"	.700"	.625"	M8 x 32mm SHCS	.105 lb
3660**	15	Standard Slide-in	Bright	1.383"	.309"	.625"	.250"	.810"	.700"	.625"	5/16-18 x 1.30" SHCS	.101 lb
3359	15	Standard Slide-in	Black	1.383"	.309"	.625"	.250"	.810"	.700"	.625"	5/16-18 x 1.30" SHCS	.102 lb
3362	15	Roll-in w/ Flex Handle	Bright	1.383"	.309"	.510"	.285"	.810"	.875"	.625"	5/16-18 x 1.30" SHCS	.099 lb
3373	15	Roll-in w/ Ball Spring	Bright	1.383"	.309"	.551"	.291"	.810"	.886"	.625"	5/16-18 x 1.30" SHCS	.099 lb
3661*	15	Drop-in	Bright	1.383"	.309"	.510"	.285"	.810"	.875"	.625"	5/16-18 x 1.25" SHCS	.099 lb
13184	20	Roll-in w/ Ball Spring	Bright	16.90mm	5.00mm	7.90mm	4.20mm	11.80mm	11.85mm	8.50mm	M4 x 14mm SHCS	.0091 kg
25-3896	25	Standard Slide-in	Bright	18.54mm	6.22mm	10.94mm	4.34mm	14.27mm	12.44mm	10.31mm	M5 x 18mm SHCS	.0145 kg
25-3392	25	Standard Slide-in	Black	18.54mm	6.22mm	10.94mm	6.35mm	14.27mm	12.44mm	10.31mm	M5 x 18mm SHCS	.0145 kg
25-3363	25	Roll-in w/ Flex Handle	Bright	18.54mm	6.22mm	10.03mm	5.08mm	14.27mm	15.74mm	10.31mm	M5 x 18mm SHCS	.0159 kg
13186	30	Economy Slide-in	Bright	25.00mm	8.00mm	13.00mm	3.39mm	15.70mm	20.60mm	12.50mm	M6 x 20mm SHCS	.0213 kg
40-3897	40	Standard Slide-in	Bright	33.00mm	7.84mm	15.87mm	6.35mm	19.93mm	17.45mm	15.97mm	M8 x 30mm SHCS	.0449 kg
40-3359	40	Standard Slide-in	Black	33.00mm	7.84mm	15.87mm	6.35mm	19.93mm	17.45mm	15.97mm	M8 x 30mm SHCS	.0449 kg
40-3362	40	Roll-in w/ Flex Handle	Bright	33.00mm	7.84mm	12.95mm	7.23mm	19.93mm	22.22mm	15.97mm	M8 x 30mm SHCS	.0446 kg

*Part number comes with stainless steel bolt and T-nut.

**Part number comes with stainless steel bolt and zinc T-nut.

CONTINUE



Anchor Fastener Cam Only

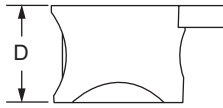
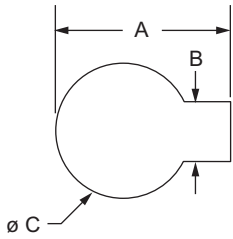

Part No.	Series	Material	Cam Color	A	B	C	D	Weight
3391	10	Zinc	Black	.730"	.245"	.562"	.406"	.015 lb
3396	10		Bright	.730"	.245"	.562"	.406"	.015 lb
3354	15		Black	1.383"	.309"	.810"	.625"	.045 lb
3361	15		Bright	1.383"	.309"	.810"	.625"	.045 lb
13183	20		Bright	16.90mm	5.00mm	11.80mm	8.50mm	.0032 kg
25-3396	25		Bright	18.54mm	6.22mm	14.27mm	10.31mm	.0069 kg
25-3391	25		Black	18.54mm	6.22mm	14.27mm	10.31mm	.0070 kg
13185	30		Bright	25.00mm	8.00mm	15.70mm	12.50mm	.0095 kg
40-3361	40		Bright	33.00mm	7.84mm	19.93mm	15.97mm	.0195 kg
40-3354	40		Black	33.00mm	7.84mm	19.93mm	15.97mm	.0195 kg

Required Machining Services

Machining Type	Profile Machined	Reference Page
Counterbore	Mounting Profile	857

Anchor Fastener Assembly

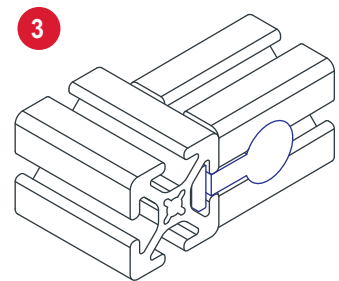
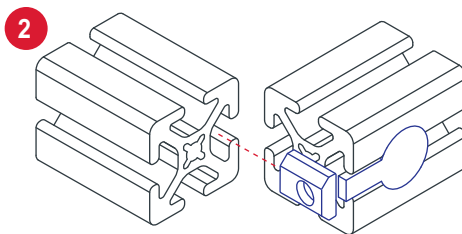
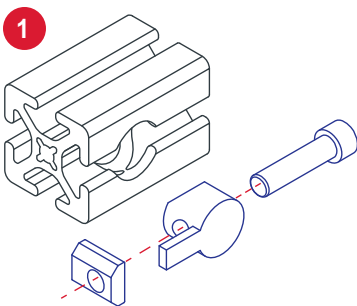

Double Anchor Fastener

Part Description:

The double anchor fastener assembly is comprised of two socket head cap screws, two cams, and a double T-nut. This design doubles the contact between the fastener and mating profile, making an extremely strong connection. The fastener provides infinite positioning along the mating profile's T-slot, allowing a large degree of adjustability. The double anchor fastener provides 90 degree, flush, vibration resistant connections, especially convenient where space restrictions apply and is used for profiles with open T-slots opposite each other. 80/20 recommends the double anchor fastener for non-column loaded supports to add extra strength. This connection method requires a counterbore machining service on the mounting profile. **Additional Information:** Cams are available separately (see page 213) for instances where you want to create your own custom assembly.

Short Double Anchor Assembly

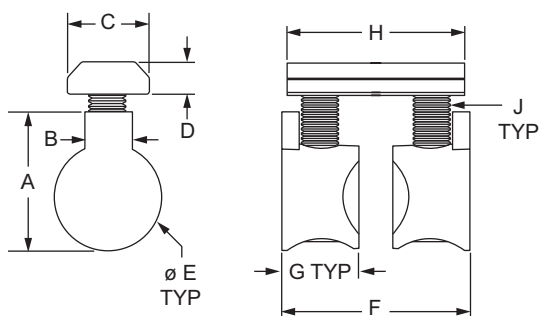

Part No.	Series	Material	Cam Color	A	B	C	D	E	F	G	H	J	Weight
3090	10	Zinc	Bright	.730"	.245"	.431"	.171"	.562"	.961"	.406"	.936"	10-32 x .75" SHCS	.061 lb
3091	10		Black	.730"	.245"	.431"	.171"	.562"	.961"	.406"	.936"	10-32 x .75" SHCS	.067 lb
3094	10		Bright	.730"	.245"	.431"	.171"	.562"	.986"	.406"	.936"	M5 x 18mm SHCS	.016 lb
3095	15		Black	1.378"	.313"	.625"	.250"	.810"	1.501"	.625"	1.437"	5/16-18 x 1.30" SHCS	.205 lb
3098	15		Bright	1.383"	.309"	.625"	.250"	.810"	1.469"	.625"	1.437"	5/16-18 x 1.30" SHCS	.205 lb
3100	15		Bright	1.383"	.309"	.625"	.250"	.810"	1.469"	.625"	1.437"	M8 x 32mm SHCS	.212 lb
25-3094	25		Bright	18.54mm	6.22mm	10.94mm	4.34mm	14.27mm	19.45mm	10.31mm	23.77mm	M5 x 18mm SHCS	.0177 kg
40-3100	40		Bright	33.00mm	7.84mm	15.87mm	6.35mm	19.93mm	39.13mm	15.97mm	38.25mm	M8 x 30mm SHCS	.0581 kg

Short Double Anchor Fastener Assembly

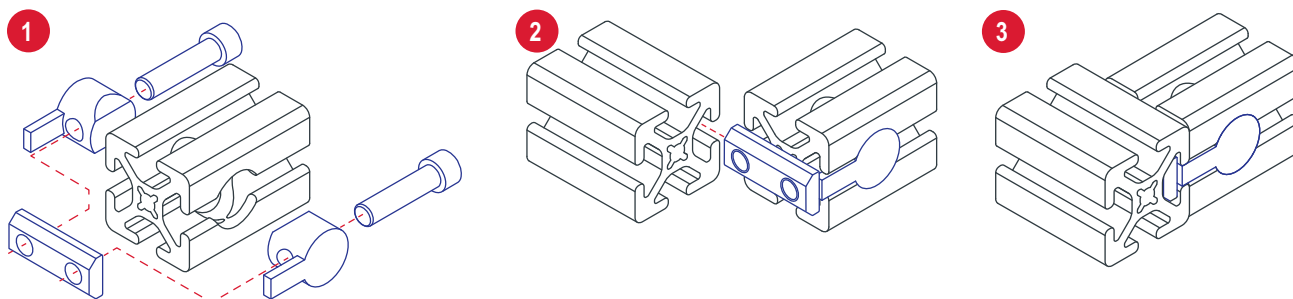

CONTINUE

Double Anchor Fastener (Continued)

Long Double Anchor Assembly

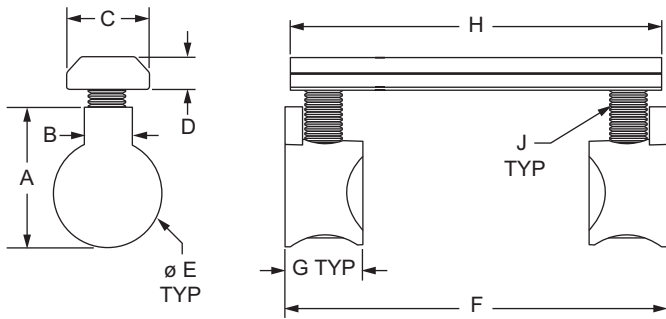

Part No.	Series	Material	Cam Color	A	B	C	D	E	F	G	H	J	Weight
3092	10	Zinc	Bright	.730"	.245"	.431"	.171"	.562"	1.961"	.406"	1.936"	10-32 x .75" SHCS	.080 lb
3093	10		Black	.730"	.245"	.431"	.171"	.562"	1.961"	.406"	1.936"	10-32 x .75" SHCS	.080 lb
3096	10		Bright	.730"	.245"	.431"	.171"	.562"	1.961"	.406"	1.936"	M5 x 18mm SHCS	.082 lb
3097	15		Black	1.383"	.309"	.625"	.250"	.810"	2.959"	.625"	2.937"	5/16-18 x 1.30" SHCS	.263 lb
3099	15		Bright	1.383"	.309"	.625"	.250"	.810"	2.959"	.625"	2.937"	5/16-18 x 1.30" SHCS	.267 lb
3102	15		Bright	1.383"	.309"	.625"	.250"	.810"	2.959"	.625"	2.937"	M8 x 32mm SHCS	.273 lb
25-3096	25		Bright	18.54mm	6.22mm	10.94mm	4.34mm	14.27mm	44.72mm	10.31mm	49.17mm	M5 x 18mm SHCS	.0263 kg
40-3102	40		Bright	33.00mm	7.84mm	15.87mm	6.35mm	19.93mm	79.07mm	15.97mm	78.15mm	M8 x 30mm SHCS	.1206 kg

Required Machining Services

Machining Type	Profile Machined	Reference Page
Counterbores	Mounting Profile	857

Long Double Anchor Fastener Assembly

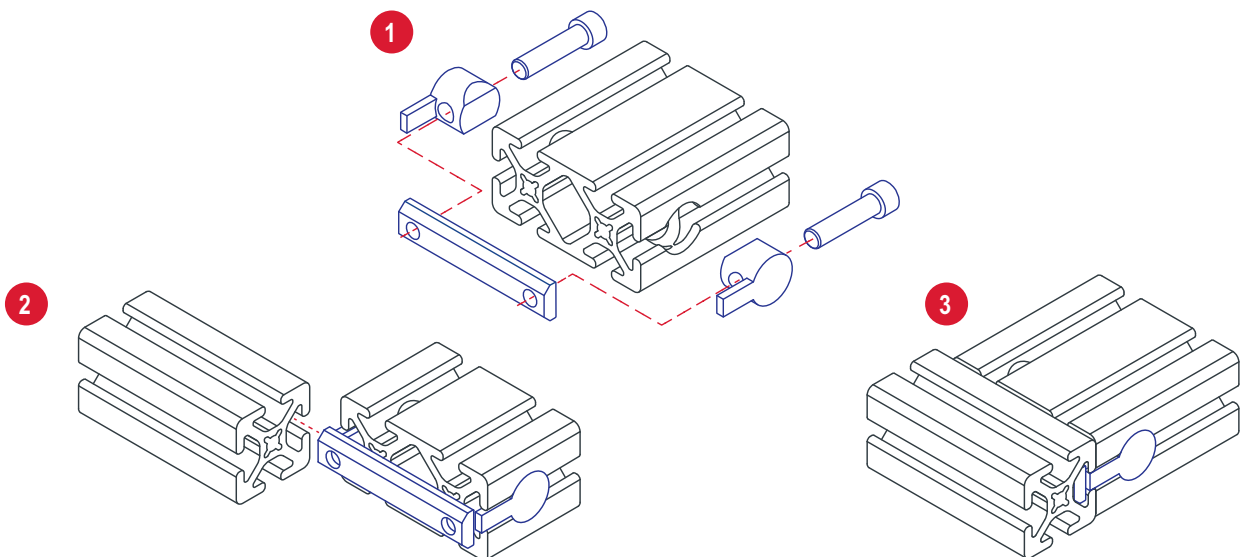

Butt Fastener

Part Description:

The butt fastener assembly is comprised of a bolt and two cams. The butt fastener connects profiles end-to-end and provides a clean, flush connection, especially convenient where space restrictions apply. The butt fastener can also be used to connect shorter bars together where logistics or space make it difficult to maneuver longer profiles. This connection method requires a counterbore machining service on each profile.

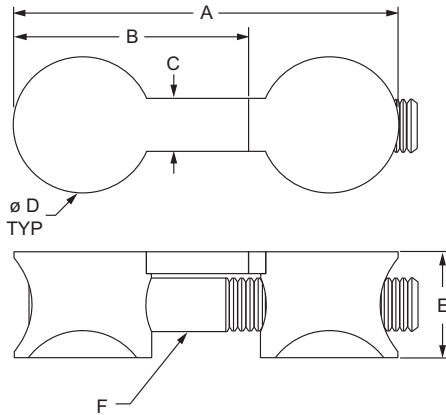

Part No.	Series	Material	Cam Color	A	B	C	D	E	F	Weight
3369	10	Zinc	Bright	1.287"	.730"	.245"	.562"	.406"	10-32 x 1.03" SHCS	.043 lb
3369-Black	10		Black	1.287"	.730"	.245"	.562"	.406"	10-32 x 1.03" SHCS	.043 lb
3370	15		Bright	2.223"	1.383"	.309"	.810"	.625"	5/16 x 1.75" SHCS	.143 lb
3370-Black	15		Black	2.223"	1.383"	.309"	.810"	.625"	5/16 x 1.75" SHCS	.143 lb
25-3369	25		Bright	37.89mm	18.54mm	6.22mm	14.14mm	10.31mm	M5 x 25mm SHCS	.0197 kg
25-3369-Black	25		Black	37.89mm	18.54mm	6.22mm	14.14mm	10.31mm	M5 x 25mm SHCS	.0197 kg
40-3370	40		Bright	58.27mm	33.00mm	7.84mm	19.93mm	15.97mm	M8 x 50mm SHCS	.0658 kg
40-3370-Black	40		Black	58.15mm	33.00mm	7.84mm	19.93mm	16.00mm	M8 x 50mm SHCS	.0658 kg

Required Machining Services

Machining Type	Profile Machined	Reference Page
Counterbore	Mounting Profiles	857

Butt Fastener Assembly

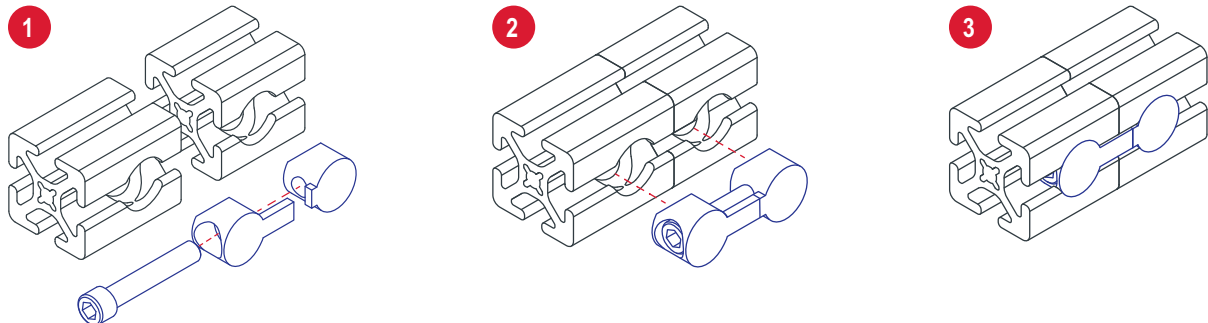



Part Description:

The standard end fastener assembly is comprised of a button head socket cap screw and wing clip. The end fastener provides a fixed, 90 degree, moderate-strength connection that is completely hidden. The winged tabs of the clip prevent the mating profile from rotating. This connection method requires two machining services; an end tap on the mounting profile and an access hole in the mating profile in order to reach the screw head. **Additional Information:** Wing clips are available separately (without the button head socket cap screw) for instances where you want to create your own custom assembly.

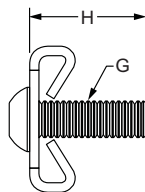
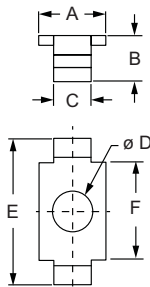

Part No.	Series	Type	Material	Color	A	B	C	D	E	F	G	H	Weight	
3381	10	Assembly	Steel	Black	.431"	.293"	.240"	.257"	.937"	.625"	1/4-20	.750"	.018 lb	
3682*	10	Assembly		Bright	.431"	.293"	.240"	.257"	.937"	.625"	1/4-20	.750"	.018 lb	
3895	10	Assembly		Bright	.431"	.293"	.240"	.257"	.937"	.625"	M6	.787"	.018 lb	
3378	10	Clip		Black	.431"	.293"	.240"	.257"	.937"	.625"	—	—	.008 lb	
3681	10	Clip		Bright	.431"	.293"	.240"	.257"	.937"	.625"	—	—	.008 lb	
3380	15	Assembly		Black	.625"	.450"	.300"	.340"	1.300"	1.000"	.625"	5/16-18	1.000"	.047 lb
3680*	15	Assembly		Bright	.625"	.450"	.300"	.340"	1.300"	1.000"	.625"	5/16-18	1.000"	.046 lb
3891	15	Assembly		Bright	.625"	.450"	.300"	.340"	1.300"	1.000"	.625"	M8	.984"	.045 lb
3379	15	Clip		Black	.625"	.450"	.300"	.340"	1.300"	1.000"	1.000"	—	—	.025 lb
3679	15	Clip		Bright	.625"	.450"	.300"	.340"	1.300"	1.000"	1.000"	—	—	.025 lb
20-3895	20	Assembly		Bright	10.00mm	4.40mm	4.80mm	5.50mm	19.00mm	16.50mm	16.50mm	M5	12.00mm	.0041 kg
20-3681	20	Clip		Bright	10.00mm	4.40mm	4.80mm	5.50mm	19.00mm	16.50mm	16.50mm	—	—	.0017 kg
25-3682*	25	Assembly		Bright	10.94mm	7.44mm	6.09mm	6.52mm	23.79mm	15.87mm	15.87mm	M6	16.00mm	.0080 kg
25-3895	25	Assembly		Bright	10.94mm	7.44mm	6.09mm	6.52mm	23.79mm	15.87mm	15.87mm	M6	16.00mm	.0082 kg
25-3681	25	Clip		Bright	10.94mm	7.44mm	6.09mm	6.52mm	23.79mm	15.87mm	15.87mm	—	—	.0045 kg
30-3891	30	Assembly		Bright	15.00mm	7.49mm	8.00mm	8.50mm	28.70mm	21.00mm	21.00mm	M8	20.00mm	.0170 kg
30-3681	30	Clip		Bright	15.00mm	7.49mm	8.00mm	8.50mm	28.70mm	21.00mm	21.00mm	—	—	.0079 kg
40-3680*	40	Assembly		Bright	15.87mm	11.43mm	7.62mm	8.63mm	33.02mm	25.40mm	25.40mm	M8	25.00mm	.0263 kg
40-3891	40	Assembly		Bright	15.87mm	11.43mm	7.62mm	8.63mm	33.02mm	25.40mm	25.40mm	M8	25.00mm	.0213 kg
40-3679	40	Clip		Bright	15.87mm	11.43mm	7.62mm	8.63mm	33.02mm	25.40mm	25.40mm	—	—	.0109 kg

*Part number comes with a stainless steel bolt.

Required Machining Services

Machining Type	Profile Machined	Reference Page
Tap Profile End	Mounting Profile	853
Access Hole	Mating Profile	855

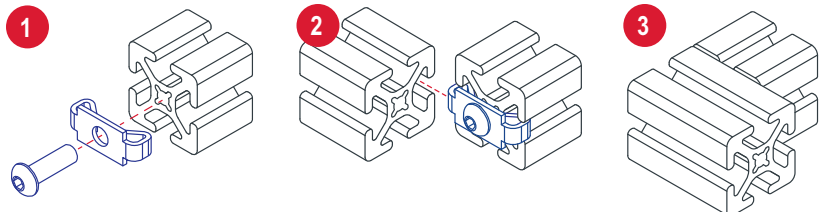

Standard End Fastener Assembly

Single Tab End Fastener

Part Description:

The single tab end fastener assembly is comprised of a button head socket cap screw and a single tab wing clip. The single tab end fastener provides a fixed, 90 degree, moderate-strength connection that is completely hidden. The single winged tab is used for closed face, radius and angled profiles; the winged tab prevents the mating profile from rotating while the straight end is flush with the mounting profile. This connection method requires two machining services; an end tap on the mounting profile and an access hole in the mating profile in order to reach the screw head. **Additional Information:** Wing clips are available separately (without the button head socket cap screw) for instances where you want to create your own custom assembly.

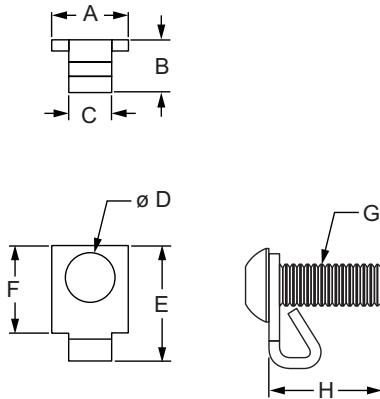

Part No.	Series	Type	Material	Color	A	B	C	D	E	F	G	H	Weight
3383	10	Assembly	Steel	Black	.431"	.293"	.240"	.275"	.645"	.489"	1/4-20	.750"	.015 lb
3183	10	Clip		Black	.431"	.293"	.240"	.275"	.645"	.489"	—	—	.005 lb
3389	15	Assembly		Black	.625"	.450"	.300"	.354"	.916"	.766"	5/16-18	1.000"	.037 lb
3189	15	Clip		Black	.625"	.450"	.300"	.354"	.916"	.766"	—	—	.010 lb
25-3383	25	Assembly		Bright	10.94mm	7.44mm	6.09mm	6.98mm	16.38mm	12.42mm	M6	16.00mm	.0068 kg
25-3183	25	Clip		Bright	10.94mm	7.44mm	6.09mm	6.98mm	16.38mm	12.42mm	—	—	.0027 kg
40-3389	40	Assembly		Bright	15.87mm	11.43mm	7.62mm	8.99mm	23.26mm	19.45mm	M8	25.00mm	.0168 kg
40-3189	40	Clip		Bright	15.87mm	11.43mm	7.62mm	8.99mm	23.26mm	19.45mm	—	—	.0064 kg

Required Machining Services

Machining Type	Profile Machined	Reference Page
Tap Profile End	Mounting Profile	853
Access Hole	Mating Profile	855

Single Tab End Fastener Assembly

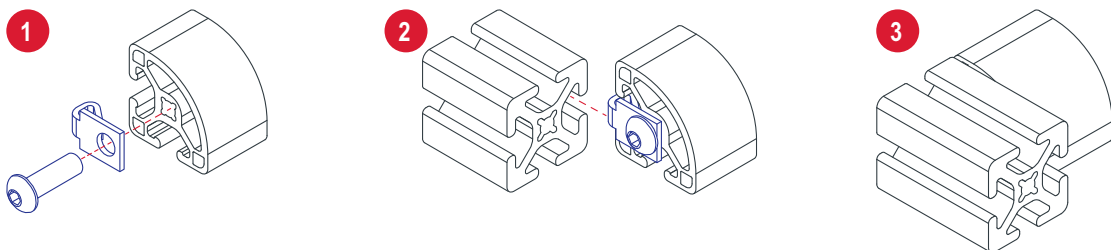

Part Description:

The double end fastener assembly is comprised of two button head socket cap screws and a double wing clip. It provides a completely hidden, fixed, 90 degree connection. The winged tabs of the clip prevent the mating profile from rotating. The double end fastener is used with larger profiles and speeds up project assembly time by replacing the need for two end fasteners. It requires an end tap service (creating two parallel through holes) on the mounting profile and two access holes in the mating profile in order to reach the screw heads. **Additional Information:** Double wing clips are available separately for instances where you want to create a custom assembly.

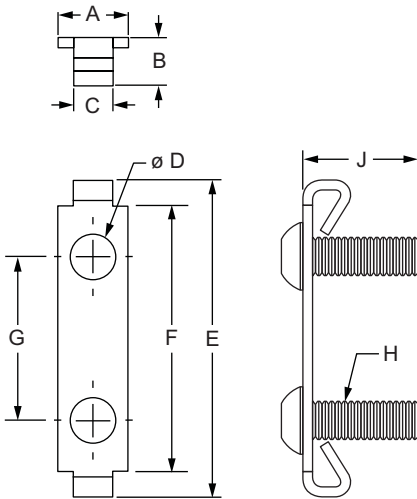

Part No.	Series	Type	Material	Color	A	B	C	D	E	F	G	H	J	Weight
3343	10	Assembly	Steel	Black	.431"	.293"	.240"	.275"	1.937"	1.625"	1.000"	1/4-20	.750"	.040 lb
3792*	10	Assembly		Bright	.431"	.293"	.240"	.275"	1.937"	1.625"	1.000"	1/4-20	.750"	.035 lb
3901	10	Assembly		Bright	.431"	.293"	.240"	.275"	1.937"	1.625"	1.000"	M6	1.000"	.034 lb
3351	10	Clip		Black	.431"	.293"	.240"	.275"	1.937"	1.625"	1.000"	—	—	.013 lb
3794*	10	Clip		Bright	.431"	.293"	.240"	.275"	1.937"	1.625"	1.000"	—	—	.010 lb
3344	15	Assembly		Black	.625"	.450"	.300"	.354"	2.800"	2.500"	1.500"	5/16-18	1.000"	.090 lb
3793*	15	Assembly		Bright	.625"	.450"	.300"	.354"	2.800"	2.500"	1.500"	5/16-18	1.000"	.091 lb
3902	15	Assembly		Bright	.625"	.450"	.300"	.354"	2.800"	2.500"	1.500"	M8	.984"	.093 lb
3352	15	Clip		Black	.625"	.450"	.300"	.354"	2.800"	2.500"	1.500"	—	—	.040 lb
3795	15	Clip		Bright	.625"	.450"	.300"	.354"	2.800"	2.500"	1.500"	—	—	.040 lb

*Part number comes with stainless steel bolts.

Double End Fastener Assembly

Required Machining Services

Machining Type	Profile Machined	Reference Page
Tap Profile End	Mounting Profile	853
Access Hole	Mating Profile	855

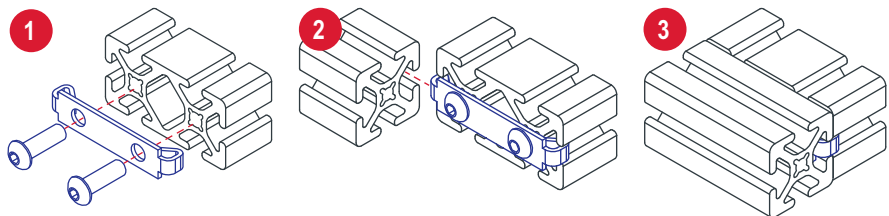

Hidden Corner Connector

Part Description:

The hidden corner connector provides a 90 degree hidden corner connection. The corner connector comes with set screws that allow for quick, easy connections. This connection can be between the inside of two profiles or between the inside of one profile and the outside of the second profile. The hidden corner connector is die cast and does not require any machining, making it a cost-effective fastening option.

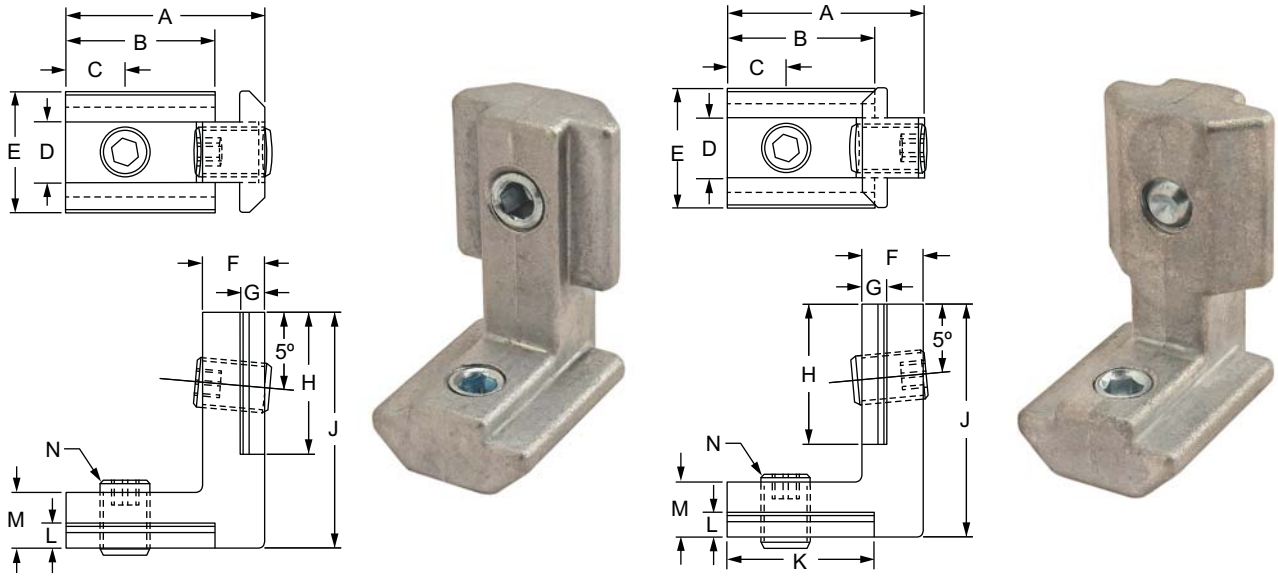

Inside-Inside Connector

Inside-Outside Connector

Part No.	Series	Type	Material	A	B	C	D	E	F	G	H	J	K	L	M	N	Weight
33450*	15 30 40	Inside-Inside	Zinc	.827"	.750"	.236"	.307"	.621"	.323"	.228"	.638"	1.181"	—	.228"	.313"	M6 x 12	.054 lb
33470*	15 30 40	Inside-Outside		.827"	.732"	.236"	.307"	.621"	.323"	.228"	.638"	1.181"	.750"	.228"	.313"	M6 x 12	.052 lb
33490**	45	Inside-Inside		32.00mm	24.00mm	9.50mm	9.80mm	19.50mm	10.00mm	4.00mm	22.90mm	38.00mm	—	4.00mm	9.00mm	M8 x 12	.0445 kg
33530**	45	Inside-Outside		32.00mm	24.00mm	9.50mm	9.80mm	19.50mm	10.00mm	4.00mm	22.90mm	38.00mm	23.98mm	4.00mm	9.00mm	M8 x 12	.0454 kg

*The suggested tool to tighten the included hardware is a 3mm hex wrench.
 **The suggested tool to tighten the included hardware is a 4mm hex wrench.

Hidden Corner Connector Assembly Inside-Outside Connector Shown

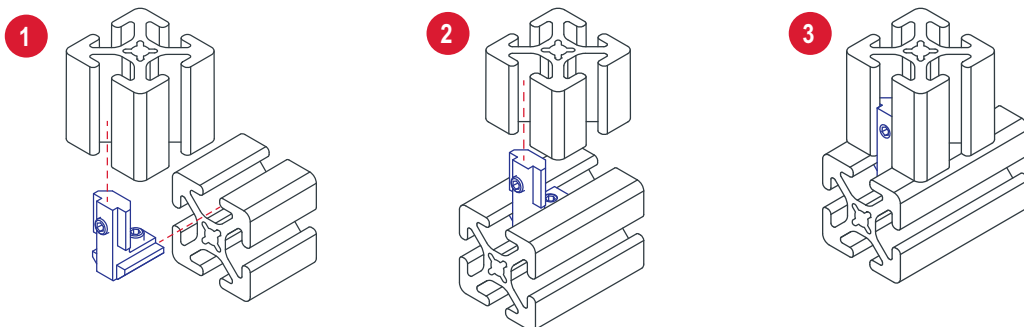



Part Description:

The miter connector creates strong, internal connections ranging from 90 degrees to 180 degrees. A miter connection reduces rotation between the profiles. This connection requires that both profiles have a miter cut machining service as well as counterbores in both the mounting and mating profiles.

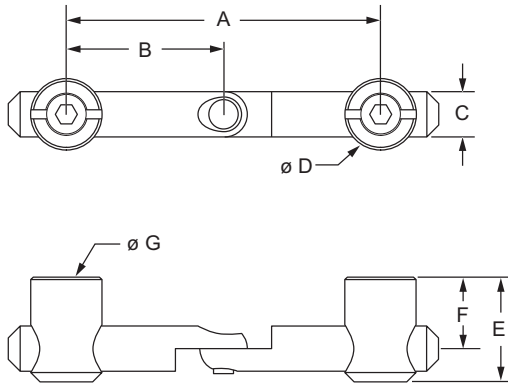

Part No.	Series	Material	Finish	A	B	C	D	E	F	G	Weight
13193	15 40 45	Steel	Bright Zinc	66.00mm (2.598")	33.00mm (1.299")	9.50mm (.374")	15.00mm (.591")	22.00mm (.866")	15.00mm (.591")	M10 x 12	.0795 kg (.175 lb)

Required Machining Services

Machining Type	Profile Machined	Reference Page
Miter Connector Profile Milling	Each Profile	868

Miter Connector Assembly

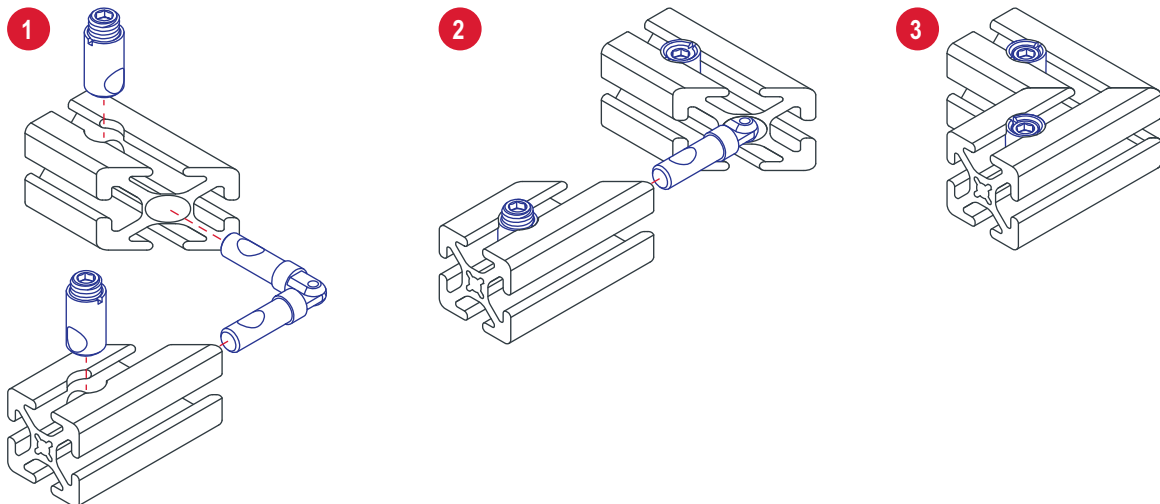

90 Degree Inside Corner Connector

Part Description:

The 90 degree inside corner connector is a strong method for creating 90 degree connections between profiles. There are options available in aluminum or zinc. The required hardware is included with the connectors and no machining services are required, making it a cost-effective fastening method. The zinc connector has a tapped hole for panel mounting. **Tip:** The suggested tool to tighten the included hardware is a 1/8" (3.175mm) hex key.

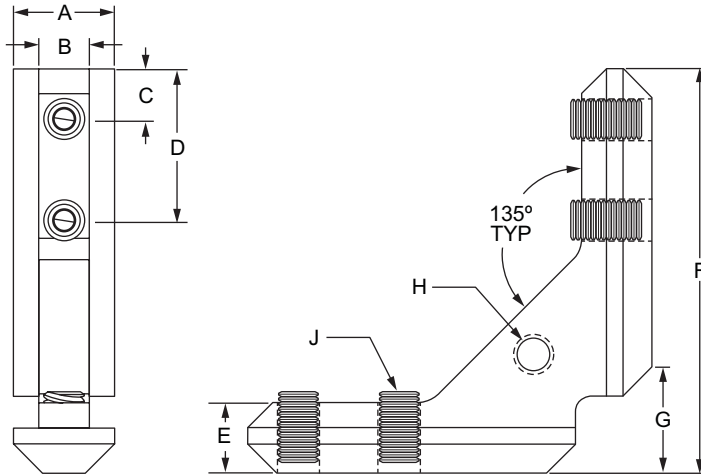

Aluminum



Zinc

Part No.	Series	Material	Finish	A	B	C	D	E	F	G	H	J	Weight
3364	15 40	Aluminum	Anodize	.625"	.313"	.312"	.937"	.436"	2.50"	.655"	—	1/4-20 x 1/2"	.097 lb
3368*	15 40	Zinc	Natural	.625"	.313"	.312"	.937"	.436"	2.50"	.655"	1/4-20 Tap	1/4-20 x 1/2"	.192 lb
40-3368*	40			15.88mm	7.95mm	7.92mm	23.79mm	11.07mm	63.50mm	16.63mm	1/4-20 Tap	1/4-20 x 1/2"	.0821 kg

*Tap thru available

90 Degree Inside Corner Connector Assembly

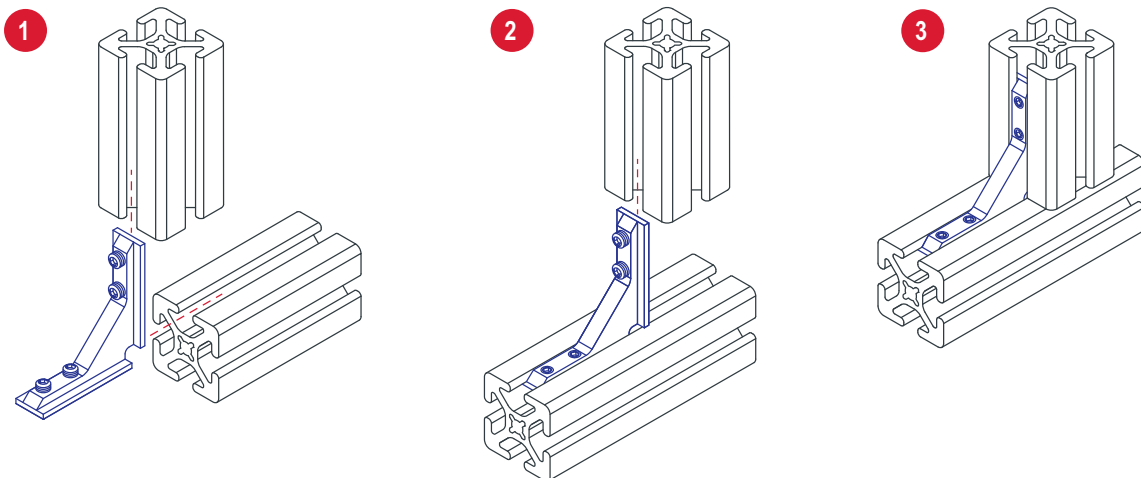

Part Description:

The central connector is an assembly comprised of a cam, conical set screw, spring, and T-stud. It is a strong internal fastening method, offering a long-lasting connection. The central connector can be used when profile ends are captivated and it provides infinite positioning along the mating profile's T-slot, allowing a large degree of adjustability. The central connector is a 90 degree, hidden, aesthetic connection. This connection method requires a counterbore machining service and profile end hole to the mounting profile.



Part No.	Series	Orientation	Spring	Material	A	B	C	D	E	F	G	H	J	K	L	Weight
13187	15 40	Vertical	Yes	Steel	2.047"	1.594"	.366"	.590"	.444"	.315"	.669"	.945"	.748"	.217"	M12 x 12	.0485 kg
13188	15 40	Horizontal			2.047"	1.594"	.366"	.590"	.444"	.748"	.669"	.945"	.315"	.217"	M12 x 12	.0462 kg
14012	45	Vertical	No		45.50mm	32.00mm	9.60mm	16.70mm	11.38mm	9.60mm	18.00mm	28.00mm	19.50mm	5.40mm	M12 x 12	.0558 kg
14013	45	Horizontal			45.50mm	32.00mm	9.60mm	16.70mm	11.38mm	19.50mm	18.00mm	28.00mm	9.60mm	5.40mm	M12 x 12	.0553 kg

Required Machining Services

Machining Type	Profile Machined	Reference Page
Central Connector Profile Milling	Mounting Profile	870

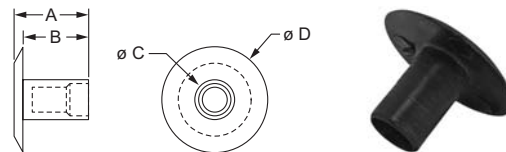

Central Connector Cover Cap

Part No.	Series	Material	A	B	C	D	Weight
13001	45	Black Nylon	12.00mm	10.50mm	6.40mm	17.00mm	.0022 Kg

Central Connector Assembly

Vertical Central Connector Shown

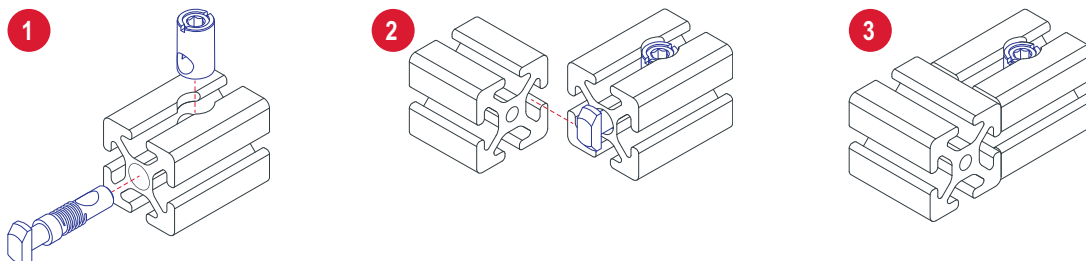

Bolt Connector

Part Description:

The bolt connector is an assembly connection providing an internal, long-lasting fastening method. The bolt connector loads from the side or end of the profile and forms a 90 degree connection. This fastening method requires only a drill through machining service to the mounting profile.



13189



13190
13192

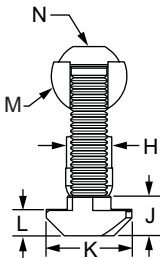
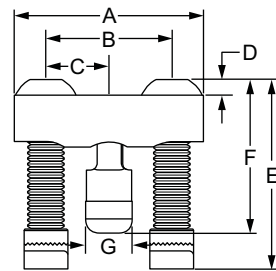
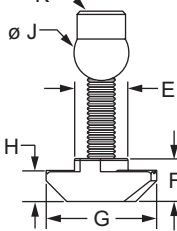
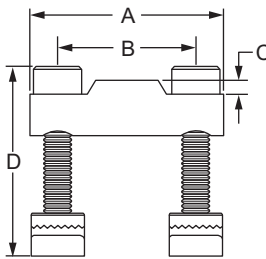

Part No.	Series	Material	A	B	C	D	E	F	G	H	J	K	L	M	N	Weight
13189	30	Steel	28.00mm	20.00mm	2.00mm	29.00mm	7.70mm	6.20mm	16.00mm	4.40mm	8.00mm	M4 x 25mm	—	—	—	.0243 kg
13190	45		42.00mm	28.00mm	14.00mm	3.40mm	44.40mm	36.50mm	10.30mm	9.70mm	8.80mm	19.00mm	5.80mm	16.80mm	M8 x 40	.0755 kg
13192	45		87.00mm	73.00mm	14.00mm	3.25mm	39.25mm	36.25mm	10.30mm	10.10mm	8.80mm	19.00mm	5.80mm	16.80mm	M8 x 35	.0130 kg

Required Machining Services

Machining Type	Profile Machined	Reference Page
Bolt Connector Profile Milling	Mounting Profile	872

Bolt Connector Assembly

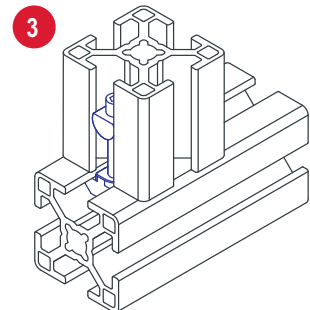
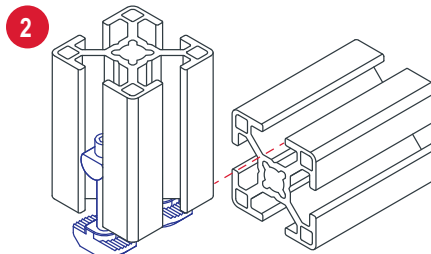
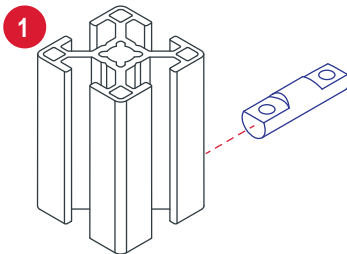

Part Description:

The plate connector is a strong external fastening method offering a long-lasting connection. The plate connector loads from the side or end of the profile and forms a 90 degree connection. The plate connector allows users to mount to the mating profile's T-slot acting as a drop-in connector. This fastening method requires only an end tap machining service to the mounting profile.

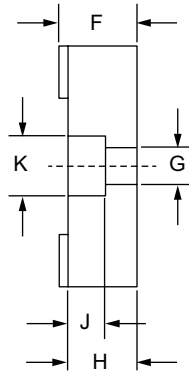
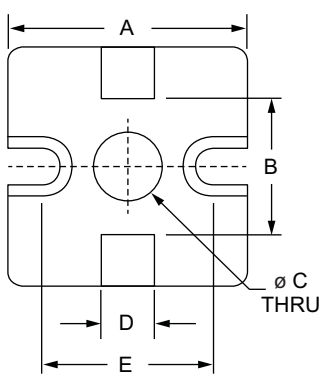

Powder Coat



Natural

Part No.	Series	Material	Finish	A	B	C	D	E	F	G	H	J	K	Weight
14137	45	Zinc	Natural	45.00mm	24.50mm	13.00mm	10.00mm	32.00mm	14.70mm	6.50mm	13.00mm	7.00mm	11.00mm	.0921 kg
14136	45		Powder Coat	45.00mm	24.50mm	13.00mm	10.00mm	32.00mm	14.70mm	6.50mm	13.00mm	7.00mm	11.00mm	.0894 kg

Required Machining Services

Machining Type	Profile Machined	Reference Page
Tap Profile End	Mounting Profile	853

Suggested Hardware (Mount to Profile)

Part No.	Series	Qty.	Description
13004	45	1	M12 x 30mm Six Lobe Screw
11-6516	45	2	M6 x 16mm SHCS
13129	45	2	M6 Drop-in T-Nut

Plate Connector Assembly

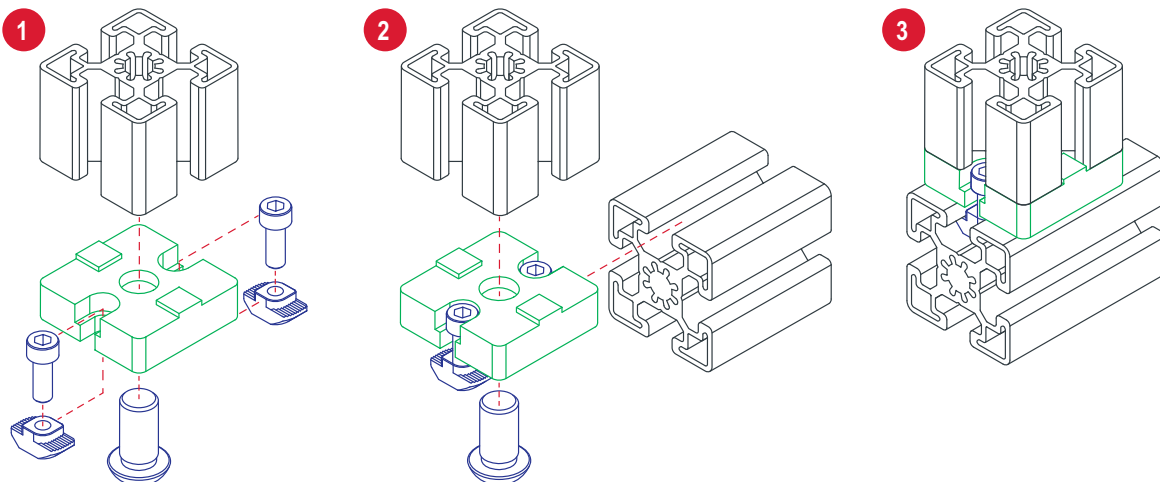

45 Degree Support Connector

Part Description:

The 45 degree support connector provides a clean, flush connection and is typically used to reinforce a 90 degree connection. It requires minimal machining (an end tap to the support bar) and mounts using standard hardware. The 45 degree support connector is designed for use with 40mm by 40mm profiles. This connection lends itself to applications with heavy loads to minimize beam deflection.

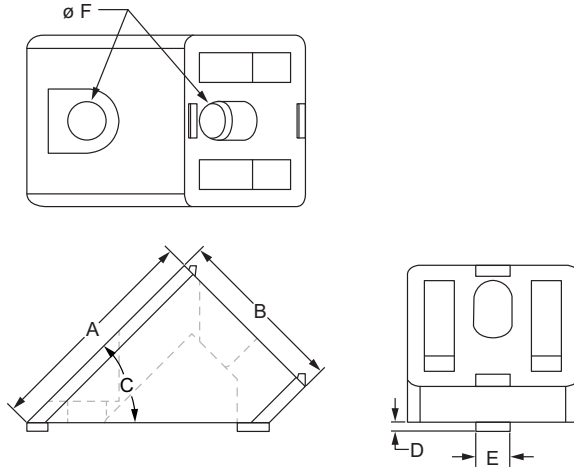

Part No.	Series	Material	Finish	A	B	C	D	E	F	Weight
14118	40	Aluminum	Clear Anodize	52.00mm	40.00mm	45°	2.00mm	8.00mm	9.00mm	.2123 kg

Required Machining Services

Machining Type	Profile Machined	Reference Page
Tap Profile End	Profile End	853

Suggested Hardware (Mount to T-Slot)

Part No.	Series	Qty.	Description	T-Nut	Location
11-8520	40	1	M8 x 20mm SHCS	—	To Profile End
75-3621	40	1	M8 x 16mm SHCS	Economy	To T-Slot

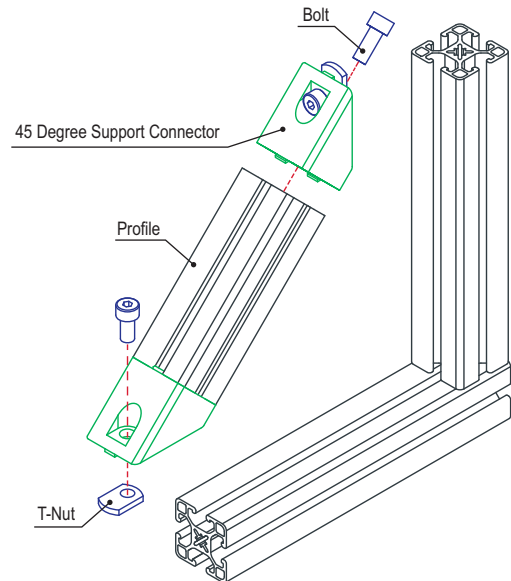

Part Description:

The 45 degree support assembly includes socket head cap screws, washers and T-nuts. The support assembly is pre-machined with counterbores and a 45 degree miter angle on both ends. This fastening method provides a clean, flush connection and is typically used to reinforce a 90 degree connection. This connection lends itself to applications with heavy loads to minimize beam deflection.

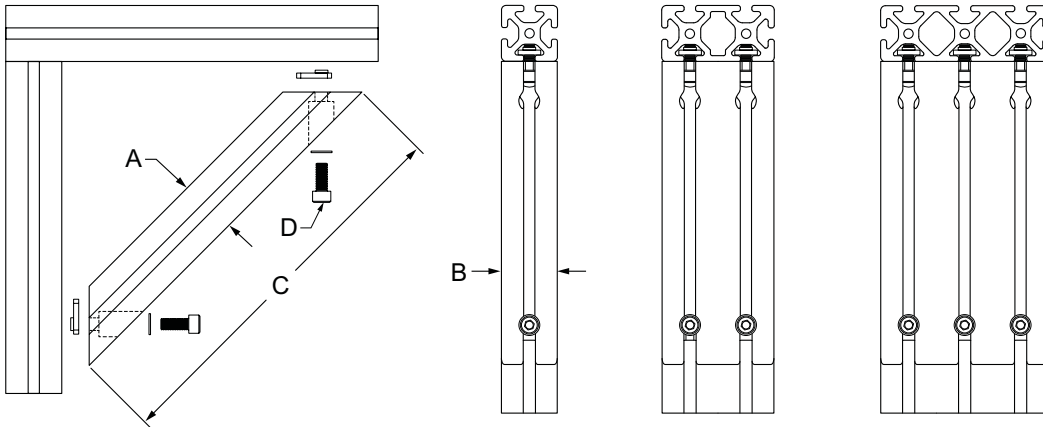

Part No.	Series	Profile	A	B	C	D (Included Hardware)						Weight	Product Representation (Length Will Vary)
						Bolt	Qty.	T-Nut	Qty.	Washer	Qty.		
2565	10	1010	1.000"	1.000"	6.000"	3067	2	3382	2	3258	2	.244 lb	
2565-Black	10	1010-Black	1.000"	1.000"	6.000"	3067	2	3382	2	3258	2	.244 lb	
2570	10	1010	1.000"	1.000"	12.000"	3067	2	3382	2	3258	2	.581 lb	
2570-Black	10	1010-Black	1.000"	1.000"	12.000"	3067	2	3382	2	3258	2	.581 lb	
2575	10	1010	1.000"	1.000"	18.000"	3067	2	3382	2	3258	2	.845 lb	
2575-Black	10	1010-Black	1.000"	1.000"	18.000"	3067	2	3382	2	3258	2	.845 lb	
2583	10	1010	1.000"	1.000"	24.000"	3067	2	3382	2	3258	2	1.056 lb	
2583-Black	10	1010-Black	1.000"	1.000"	24.000"	3067	2	3382	2	3258	2	1.056 lb	
2566	10	1020	1.000"	2.000"	6.000"	3067	4	3382	4	3258	4	.573 lb	
2566-Black	10	1020-Black	1.000"	2.000"	6.000"	3067	4	3382	4	3258	4	.573 lb	
2567	10	1020	1.000"	2.000"	12.000"	3067	4	3382	4	3258	4	1.041 lb	
2567-Black	10	1020-Black	1.000"	2.000"	12.000"	3067	4	3382	4	3258	4	1.041 lb	
2568	10	1020	1.000"	2.000"	18.000"	3067	4	3382	4	3258	4	1.509 lb	
2568-Black	10	1020-Black	1.000"	2.000"	18.000"	3067	4	3382	4	3258	4	1.509 lb	
2584	10	1020	1.000"	2.000"	24.000"	3067	4	3382	4	3258	4	1.872 lb	
2584-Black	10	1020-Black	1.000"	2.000"	24.000"	3067	4	3382	4	3258	4	1.872 lb	
2571	10	1030	1.000"	3.000"	6.000"	3067	6	3382	6	3258	6	.660 lb	
2571-Black	10	1030-Black	1.000"	3.000"	6.000"	3067	6	3382	6	3258	6	.660 lb	
2572	10	1030	1.000"	3.000"	12.000"	3067	6	3382	6	3258	6	1.579 lb	
2572-Black	10	1030-Black	1.000"	3.000"	12.000"	3067	6	3382	6	3258	6	1.579 lb	
2573	10	1030	1.000"	3.000"	18.000"	3067	6	3382	6	3258	6	2.263 lb	
2573-Black	10	1030-Black	1.000"	3.000"	18.000"	3067	6	3382	6	3258	6	2.263 lb	
2574	10	1030	1.000"	3.000"	24.000"	3067	6	3382	6	3258	6	2.669 lb	
2574-Black	10	1030-Black	1.000"	3.000"	24.000"	3067	6	3382	6	3258	6	2.669 lb	

CONTINUE

45 Degree Supports (Continued)

Part No.	Series	Profile	A	B	C	D (Included Hardware)						Weight	Product Representation (Length Will Vary)
						Bolt	Qty.	T-Nut	Qty.	Washer	Qty.		
2556	15	1501	1.500"	1.500"	6.000"	3112	2	3278	2	3260	6	.517 lb	
2556-Black	15	1501-Black	1.500"	1.500"	6.000"	3112	2	3278	2	3260	6	.517 lb	
2557	15	1501	1.500"	1.500"	12.000"	3112	2	3278	2	3260	6	1.096 lb	
2557-Black	15	1501-Black	1.500"	1.500"	12.000"	3112	2	3278	2	3260	6	1.096 lb	
2558	15	1501	1.500"	1.500"	18.000"	3112	2	3278	2	3260	6	1.594 lb	
2558-Black	15	1501-Black	1.500"	1.500"	18.000"	3112	2	3278	2	3260	6	1.594 lb	
2559	15	1501	1.500"	1.500"	24.000"	3112	2	3278	2	3260	6	2.092 lb	
2559-Black	15	1501-Black	1.500"	1.500"	24.000"	3112	2	3278	2	3260	6	2.092 lb	
2533	15	1515-ULS	1.500"	1.500"	6.000"	3112	2	3278	2	3260	2	.568 lb	
2533-Black	15	1515-ULS-Black	1.500"	1.500"	6.000"	3112	2	3278	2	3260	2	.568 lb	
2534	15	1515-ULS	1.500"	1.500"	12.000"	3112	2	3278	2	3260	2	1.036 lb	
2534-Black	15	1515-ULS-Black	1.500"	1.500"	12.000"	3112	2	3278	2	3260	2	1.036 lb	
2537	15	1515-ULS	1.500"	1.500"	18.000"	3112	2	3278	2	3260	2	1.504 lb	
2537-Black	15	1515-ULS-Black	1.500"	1.500"	18.000"	3112	2	3278	2	3260	2	1.504 lb	
2538	15	1515-ULS	1.500"	1.500"	24.000"	3112	2	3278	2	3260	2	1.972 lb	
2538-Black	15	1515-ULS-Black	1.500"	1.500"	24.000"	3112	2	3278	2	3260	2	1.972 lb	
2527	15	1515-UL	1.500"	1.500"	6.000"	3112	2	3278	2	3260	2	.579 lb	
2527-Black	15	1515-UL-Black	1.500"	1.500"	6.000"	3112	2	3278	2	3260	2	.579 lb	
2528	15	1515-UL	1.500"	1.500"	12.000"	3112	2	3278	2	3260	2	1.053 lb	
2528-Black	15	1515-UL-Black	1.500"	1.500"	12.000"	3112	2	3278	2	3260	2	1.053 lb	
2529	15	1515-UL	1.500"	1.500"	18.000"	3112	2	3278	2	3260	2	1.529 lb	
2529-Black	15	1515-UL-Black	1.500"	1.500"	18.000"	3112	2	3278	2	3260	2	1.529 lb	
2532	15	1515-UL	1.500"	1.500"	24.000"	3112	2	3278	2	3260	2	2.006 lb	
2532-Black	15	1515-UL-Black	1.500"	1.500"	24.000"	3112	2	3278	2	3260	2	2.006 lb	
2539	15	1515-LS	1.500"	1.500"	6.000"	3112	2	3278	2	3260	2	.626 lb	
2539-Black	15	1515-LS-Black	1.500"	1.500"	6.000"	3112	2	3278	2	3260	2	.626 lb	
2542	15	1515-LS	1.500"	1.500"	12.000"	3112	2	3278	2	3260	2	1.115 lb	
2542-Black	15	1515-LS-Black	1.500"	1.500"	12.000"	3112	2	3278	2	3260	2	1.115 lb	
2543	15	1515-LS	1.500"	1.500"	18.000"	3112	2	3278	2	3260	2	1.679 lb	
2543-Black	15	1515-LS-Black	1.500"	1.500"	18.000"	3112	2	3278	2	3260	2	1.679 lb	
2544	15	1515-LS	1.500"	1.500"	24.000"	3112	2	3278	2	3260	2	2.206 lb	
2544-Black	15	1515-LS-Black	1.500"	1.500"	24.000"	3112	2	3278	2	3260	2	2.206 lb	
2562	15	1515-Lite	1.500"	1.500"	6.000"	3112	2	3278	2	3260	2	.447 lb	
2562-Black	15	1515-Lite-Black	1.500"	1.500"	6.000"	3112	2	3278	2	3260	2	.447 lb	
2561	15	1515-Lite	1.500"	1.500"	12.000"	3112	2	3278	2	3260	2	1.168 lb	
2561-Black	15	1515-Lite-Black	1.500"	1.500"	12.000"	3112	2	3278	2	3260	2	1.168 lb	
2563	15	1515-Lite	1.500"	1.500"	18.000"	3112	2	3278	2	3260	2	1.702 lb	
2563-Black	15	1515-Lite-Black	1.500"	1.500"	18.000"	3112	2	3278	2	3260	2	1.702 lb	
2564	15	1515-Lite	1.500"	1.500"	24.000"	3112	2	3278	2	3260	2	2.236 lb	
2564-Black	15	1515-Lite-Black	1.500"	1.500"	24.000"	3112	2	3278	2	3260	2	2.236 lb	
2546	15	1515-S	1.500"	1.500"	6.000"	3112	2	3278	2	3260	2	.787 lb	
2546-Black	15	1515-S-Black	1.500"	1.500"	6.000"	3112	2	3278	2	3260	2	.787 lb	
2547	15	1515-S	1.500"	1.500"	12.000"	3112	2	3278	2	3260	2	1.475 lb	
2547-Black	15	1515-S-Black	1.500"	1.500"	12.000"	3112	2	3278	2	3260	2	1.475 lb	
2548	15	1515-S	1.500"	1.500"	18.000"	3112	2	3278	2	3260	2	2.162 lb	
2548-Black	15	1515-S-Black	1.500"	1.500"	18.000"	3112	2	3278	2	3260	2	2.162 lb	
2549	15	1515-S	1.500"	1.500"	24.000"	3112	2	3278	2	3260	2	2.850 lb	
2549-Black	15	1515-S-Black	1.500"	1.500"	24.000"	3112	2	3278	2	3260	2	2.850 lb	

View page 227 for dimensional drawing

CONTINUE

Part No.	Series	Profile	A	B	C	D (Included Hardware)						Weight	Product Representation (Length Will Vary)
						Bolt	Qty.	T-Nut	Qty.	Washer	Qty.		
2525	15	1515	1.500"	1.500"	6.000"	3112	2	3278	2	3260	2	.706 lb	
2525-Black	15	1515-Black	1.500"	1.500"	6.000"	3112	2	3278	2	3260	2	.706 lb	
2535	15	1515	1.500"	1.500"	12.000"	3112	2	3278	2	3260	2	1.492 lb	
2535-Black	15	1515-Black	1.500"	1.500"	12.000"	3112	2	3278	2	3260	2	1.492 lb	
2545	15	1515	1.500"	1.500"	18.000"	3112	2	3278	2	3260	2	2.188 lb	
2545-Black	15	1515-Black	1.500"	1.500"	18.000"	3112	2	3278	2	3260	2	2.188 lb	
2555	15	1515	1.500"	1.500"	24.000"	3112	2	3278	2	3260	2	2.884 lb	
2555-Black	15	1515-Black	1.500"	1.500"	24.000"	3112	2	3278	2	3260	2	2.884 lb	
2551	15	1530-LS	1.500"	3.000"	6.000"	3112	4	3278	4	3260	4	1.216 lb	
2551-Black	15	1530-LS-Black	1.500"	3.000"	6.000"	3112	4	3278	4	3260	4	1.216 lb	
2552	15	1530-LS	1.500"	3.000"	12.000"	3112	4	3278	4	3260	4	2.233 lb	
2552-Black	15	1530-LS-Black	1.500"	3.000"	12.000"	3112	4	3278	4	3260	4	2.233 lb	
2553	15	1530-LS	1.500"	3.000"	18.000"	3112	4	3278	4	3260	4	3.250 lb	
2553-Black	15	1530-LS-Black	1.500"	3.000"	18.000"	3112	4	3278	4	3260	4	3.250 lb	
2554	15	1530-LS	1.500"	3.000"	24.000"	3112	4	3278	4	3260	4	4.267 lb	
2554-Black	15	1530-LS-Black	1.500"	3.000"	24.000"	3112	4	3278	4	3260	4	4.267 lb	
2578	15	1530-Lite	1.500"	3.000"	6.000"	3112	4	3278	4	3260	4	.865 lb	
2578-Black	15	1530-Lite-Black	1.500"	3.000"	6.000"	3112	4	3278	4	3260	4	.865 lb	
2579	15	1530-Lite	1.500"	3.000"	12.000"	3112	4	3278	4	3260	4	2.263 lb	
2579-Black	15	1530-Lite-Black	1.500"	3.000"	12.000"	3112	4	3278	4	3260	4	2.263 lb	
2580	15	1530-Lite	1.500"	3.000"	18.000"	3112	4	3278	4	3260	4	3.295 lb	
2580-Black	15	1530-Lite-Black	1.500"	3.000"	18.000"	3112	4	3278	4	3260	4	3.295 lb	
2581	15	1530-Lite	1.500"	3.000"	24.000"	3112	4	3278	4	3260	4	4.327 lb	
2581-Black	15	1530-Lite-Black	1.500"	3.000"	24.000"	3112	4	3278	4	3260	4	4.327 lb	
2569	15	1530-S	1.500"	3.000"	6.000"	3112	4	3278	4	3260	4	1.429 lb	
2569-Black	15	1530-S-Black	1.500"	3.000"	6.000"	3112	4	3278	4	3260	4	1.429 lb	
2576	15	1530-S	1.500"	3.000"	12.000"	3112	4	3278	4	3260	4	2.658 lb	
2576-Black	15	1530-S-Black	1.500"	3.000"	12.000"	3112	4	3278	4	3260	4	2.658 lb	
2577	15	1530-S	1.500"	3.000"	18.000"	3112	4	3278	4	3260	4	3.887 lb	
2577-Black	15	1530-S-Black	1.500"	3.000"	18.000"	3112	4	3278	4	3260	4	3.887 lb	
2582	15	1530-S	1.500"	3.000"	24.000"	3112	4	3278	4	3260	4	5.117 lb	
2582-Black	15	1530-S-Black	1.500"	3.000"	24.000"	3112	4	3278	4	3260	4	5.117 lb	
2530	15	1530	1.500"	3.000"	6.000"	3112	4	3278	4	3260	4	1.021 lb	
2530-Black	15	1530-Black	1.500"	3.000"	6.000"	3112	4	3278	4	3260	4	1.021 lb	
2540	15	1530	1.500"	3.000"	12.000"	3112	4	3278	4	3260	4	2.707 lb	
2540-Black	15	1530-Black	1.500"	3.000"	12.000"	3112	4	3278	4	3260	4	2.707 lb	
2550	15	1530	1.500"	3.000"	18.000"	3112	4	3278	4	3260	4	3.961 lb	
2550-Black	15	1530-Black	1.500"	3.000"	18.000"	3112	4	3278	4	3260	4	3.961 lb	
2560	15	1530	1.500"	3.000"	24.000"	3112	4	3278	4	3260	4	5.215 lb	
2560-Black	15	1530-Black	1.500"	3.000"	24.000"	3112	4	3278	4	3260	4	5.215 lb	
2526	15	1545	1.500"	4.500"	6.000"	3112	6	3278	6	3260	6	1.495 lb	
2526-Black	15	1545-Black	1.500"	4.500"	6.000"	3112	6	3278	6	3260	6	1.495 lb	
2531	15	1545	1.500"	4.500"	12.000"	3112	6	3278	6	3260	6	3.199 lb	
2531-Black	15	1545-Black	1.500"	4.500"	12.000"	3112	6	3278	6	3260	6	3.199 lb	
2536	15	1545	1.500"	4.500"	18.000"	3112	6	3278	6	3260	6	6.203 lb	
2536-Black	15	1545-Black	1.500"	4.500"	18.000"	3112	6	3278	6	3260	6	6.203 lb	
2541	15	1545	1.500"	4.500"	24.000"	3112	6	3278	6	3260	6	8.171 lb	
2541-Black	15	1545-Black	1.500"	4.500"	24.000"	3112	6	3278	6	3260	6	8.171 lb	

FASTENERS

View page 227 for dimensional drawing

CONTINUE

45 Degree Supports (Continued)

Part No.	Series	Profile	A	B	C	D (Included Hardware)						Weight	Product Representation (Length Will Vary)
						Bolt	Qty.	T-Nut	Qty.	Washer	Qty.		
20-2565	20	20-2020	20.00mm	20.00mm	160.00mm	11-5512	2	14122	2	11-6040	2	.0790 kg	
20-2565-Black	20	20-2020-Black	20.00mm	20.00mm	160.00mm	11-5512	2	14122	2	11-6040	2	.0790 kg	
20-2570	20	20-2020	20.00mm	20.00mm	320.00mm	11-5512	2	14122	2	11-6040	2	.1324 kg	
20-2570-Black	20	20-2020-Black	20.00mm	20.00mm	320.00mm	11-5512	2	14122	2	11-6040	2	.1324 kg	
20-2575	20	20-2020	20.00mm	20.00mm	480.00mm	11-5512	2	14122	2	11-6040	2	.2186 kg	
20-2575-Black	20	20-2020-Black	20.00mm	20.00mm	480.00mm	11-5512	2	14122	2	11-6040	2	.2186 kg	
20-2566	20	20-2040	20.00mm	40.00mm	160.00mm	11-5512	4	14122	4	11-6040	4	.1360 kg	
20-2566-Black	20	20-2040-Black	20.00mm	40.00mm	160.00mm	11-5512	4	14122	4	11-6040	4	.1360 kg	
20-2567	20	20-2040	20.00mm	40.00mm	320.00mm	11-5512	4	14122	4	11-6040	4	.2522 kg	
20-2567-Black	20	20-2040-Black	20.00mm	40.00mm	320.00mm	11-5512	4	14122	4	11-6040	4	.2522 kg	
20-2568	20	20-2040	20.00mm	40.00mm	480.00mm	11-5512	4	14122	4	11-6040	4	.3579 kg	
20-2568-Black	20	20-2040-Black	20.00mm	40.00mm	480.00mm	11-5512	4	14122	4	11-6040	4	.3579 kg	

Part No.	Series	Profile	A	B	C	D (Included Hardware)						Weight	Product Representation (Length Will Vary)
						Bolt	Qty.	T-Nut	Qty.	Washer	Qty.		
25-2565	25	25-2525	25.00mm	25.00mm	160.00mm	13-6512	2	3859	2	13-6045	2	.1173 kg	
25-2565-Black	25	25-2525-Black	25.00mm	25.00mm	160.00mm	13-6512	2	3859	2	13-6045	2	.1173 kg	
25-2570	25	25-2525	25.00mm	25.00mm	320.00mm	13-6512	2	3859	2	13-6045	2	.2312 kg	
25-2570-Black	25	25-2525-Black	25.00mm	25.00mm	320.00mm	13-6512	2	3859	2	13-6045	2	.2312 kg	
25-2575	25	25-2525	25.00mm	25.00mm	480.00mm	13-6512	2	3859	2	13-6045	2	.3274 kg	
25-2575-Black	25	25-2525-Black	25.00mm	25.00mm	480.00mm	13-6512	2	3859	2	13-6045	2	.3274 kg	
25-2566	25	25-2550	25.00mm	50.00mm	160.00mm	13-6512	4	3859	4	13-6045	4	.2045 kg	
25-2566-Black	25	25-2550-Black	25.00mm	50.00mm	160.00mm	13-6512	4	3859	4	13-6045	4	.2045 kg	
25-2567	25	25-2550	25.00mm	50.00mm	320.00mm	13-6512	4	3859	4	13-6045	4	.4150 kg	
25-2567-Black	25	25-2550-Black	25.00mm	50.00mm	320.00mm	13-6512	4	3859	4	13-6045	4	.4150 kg	
25-2568	25	25-2550	25.00mm	50.00mm	480.00mm	13-6512	4	3859	4	13-6045	4	.5775 kg	
25-2568-Black	25	25-2550-Black	25.00mm	50.00mm	480.00mm	13-6512	4	3859	4	13-6045	4	.5775 kg	

Part No.	Series	Profile	A	B	C	D (Included Hardware)						Weight	Product Representation (Length Will Vary)
						Bolt	Qty.	T-Nut	Qty.	Washer	Qty.		
30-2565	30	30-3030	30.00mm	30.00mm	160.00mm	11-8516	2	13025	2	11-6042	2	.1791 kg	
30-2565-Black	30	30-3030-Black	30.00mm	30.00mm	160.00mm	11-8516	2	13025	2	11-6042	2	.1791 kg	
30-2570	30	30-3030	30.00mm	30.00mm	320.00mm	11-8516	2	13025	2	11-6042	2	.3184 kg	
30-2570-Black	30	30-3030-Black	30.00mm	30.00mm	320.00mm	11-8516	2	13025	2	11-6042	2	.3184 kg	
30-2575	30	30-3030	30.00mm	30.00mm	480.00mm	11-8516	2	13025	2	11-6042	2	.4576 kg	
30-2575-Black	30	30-3030-Black	30.00mm	30.00mm	480.00mm	11-8516	2	13025	2	11-6042	2	.4576 kg	
30-2566	30	30-3060	30.00mm	60.00mm	160.00mm	11-8516	4	13025	4	11-6042	4	.1718 kg	
30-2566-Black	30	30-3060-Black	30.00mm	60.00mm	160.00mm	11-8516	4	13025	4	11-6042	4	.1718 kg	
30-2567	30	30-3060	30.00mm	60.00mm	320.00mm	11-8516	4	13025	4	11-6042	4	.5421 kg	
30-2567-Black	30	30-3060-Black	30.00mm	60.00mm	320.00mm	11-8516	4	13025	4	11-6042	4	.5421 kg	
30-2568	30	30-3060	30.00mm	60.00mm	480.00mm	11-8516	4	13025	4	11-6042	4	.8505 kg	
30-2568-Black	30	30-3060-Black	30.00mm	60.00mm	480.00mm	11-8516	4	13025	4	11-6042	4	.8505 kg	
30-2569	30	30-3060	30.00mm	60.00mm	640.00mm	11-8516	4	13025	4	11-6042	4	1.1075 kg	
30-2569-Black	30	30-3060-Black	30.00mm	60.00mm	640.00mm	11-8516	4	13025	4	11-6042	4	1.1075 kg	

View page 227 for dimensional drawing

CONTINUE



45 Degree Supports (Continued)

Part No.	Series	Profile	A	B	C	D (Included Hardware)						Weight	Product Representation (Length Will Vary)
						Bolt	Qty.	T-Nut	Qty.	Washer	Qty.		
40-2525	40	40-4040	40.00mm	40.00mm	160.00mm	13-8518	2	3838	2	13-6042	2	.3099 kg	
40-2525-Black	40	40-4040-Black	40.00mm	40.00mm	160.00mm	13-8518	2	3838	2	13-6042	2	.3099 kg	
40-2535	40	40-4040	40.00mm	40.00mm	320.00mm	13-8518	2	3838	2	13-6042	2	.7842 kg	
40-2535-Black	40	40-4040-Black	40.00mm	40.00mm	320.00mm	13-8518	2	3838	2	13-6042	2	.7842 kg	
40-2545	40	40-4040	40.00mm	40.00mm	480.00mm	13-8518	2	3838	2	13-6042	2	.8981 kg	
40-2545-Black	40	40-4040-Black	40.00mm	40.00mm	480.00mm	13-8518	2	3838	2	13-6042	2	.8981 kg	
40-2555	40	40-4040	40.00mm	40.00mm	640.00mm	13-8518	2	3838	2	13-6042	2	1.2165 kg	
40-2555-Black	40	40-4040-Black	40.00mm	40.00mm	640.00mm	13-8518	2	3838	2	13-6042	2	1.2165 kg	
40-2562	40	40-4040-Lite	40.00mm	40.00mm	160.00mm	13-8518	2	3838	2	13-6042	2	.2414 kg	
40-2562-Black	40	40-4040-Lite-Black	40.00mm	40.00mm	160.00mm	13-8518	2	3838	2	13-6042	2	.2414 kg	
40-2561	40	40-4040-Lite	40.00mm	40.00mm	320.00mm	13-8518	2	3838	2	13-6042	2	.5175 kg	
40-2561-Black	40	40-4040-Lite-Black	40.00mm	40.00mm	320.00mm	13-8518	2	3838	2	13-6042	2	.5175 kg	
40-2563	40	40-4040-Lite	40.00mm	40.00mm	480.00mm	13-8518	2	3838	2	13-6042	2	.9001 kg	
40-2563-Black	40	40-4040-Lite-Black	40.00mm	40.00mm	480.00mm	13-8518	2	3838	2	13-6042	2	.9001 kg	
40-2564	40	40-4040-Lite	40.00mm	40.00mm	640.00mm	13-8518	2	3838	2	13-6042	2	.8772 kg	
40-2564-Black	40	40-4040-Lite-Black	40.00mm	40.00mm	640.00mm	13-8518	2	3838	2	13-6042	2	.8772 kg	
40-2530	40	40-4080	40.00mm	80.00mm	160.00mm	13-8518	4	3838	4	13-6042	4	.7411 kg	
40-2530-Black	40	40-4080-Black	40.00mm	80.00mm	160.00mm	13-8518	4	3838	4	13-6042	4	.7411 kg	
40-2540	40	40-4080	40.00mm	80.00mm	320.00mm	13-8518	4	3838	4	13-6042	4	1.1910 kg	
40-2540-Black	40	40-4080-Black	40.00mm	80.00mm	320.00mm	13-8518	4	3838	4	13-6042	4	1.1910 kg	
40-2550	40	40-4080	40.00mm	80.00mm	480.00mm	13-8518	4	3838	4	13-6042	4	1.9075 kg	
40-2550-Black	40	40-4080-Black	40.00mm	80.00mm	480.00mm	13-8518	4	3838	4	13-6042	4	1.9075 kg	
40-2560	40	40-4080	40.00mm	80.00mm	640.00mm	13-8518	4	3838	4	13-6042	4	2.7006 kg	
40-2560-Black	40	40-4080-Black	40.00mm	80.00mm	640.00mm	13-8518	4	3838	4	13-6042	4	2.7006 kg	
40-2578	40	40-4080-Lite	40.00mm	80.00mm	160.00mm	13-8518	4	3838	4	13-6042	4	.5919 kg	
40-2578-Black	40	40-4080-Lite-Black	40.00mm	80.00mm	160.00mm	13-8518	4	3838	4	13-6042	4	.5919 kg	
40-2579	40	40-4080-Lite	40.00mm	80.00mm	320.00mm	13-8518	4	3838	4	13-6042	4	1.2491 kg	
40-2579-Black	40	40-4080-Lite-Black	40.00mm	80.00mm	320.00mm	13-8518	4	3838	4	13-6042	4	1.2491 kg	
40-2580	40	40-4080-Lite	40.00mm	80.00mm	480.00mm	13-8518	4	3838	4	13-6042	4	1.3580 kg	
40-2580-Black	40	40-4080-Lite-Black	40.00mm	80.00mm	480.00mm	13-8518	4	3838	4	13-6042	4	1.3580 kg	
40-2581	40	40-4080-Lite	40.00mm	80.00mm	640.00mm	13-8518	4	3838	4	13-6042	4	1.9590 kg	
40-2581-Black	40	40-4080-Lite-Black	40.00mm	80.00mm	640.00mm	13-8518	4	3838	4	13-6042	4	1.9590 kg	

View page 227 for dimensional drawing

CONTINUE

45 Degree Supports (Continued)

Part No.	Series	Profile	A	B	C	D (Included Hardware)						Weight	Product Representation (Length Will Vary)	
						Bolt	Qty.	T-Nut	Qty.	Washer	Qty.			
45-2525	45	45-4545	45.00mm	45.00mm	160.00mm	11-8520	2	13049	2	11-6042	2	.2818 kg		
45-2525-Black	45	45-4545-Black	45.00mm	45.00mm	160.00mm	11-8520	2	13049	2	11-6042	2	.2818 kg		
45-2535	45	45-4545	45.00mm	45.00mm	320.00mm	11-8520	2	13049	2	11-6042	2	.7378 kg		
45-2535-Black	45	45-4545-Black	45.00mm	45.00mm	320.00mm	11-8520	2	13049	2	11-6042	2	.7378 kg		
45-2545	45	45-4545	45.00mm	45.00mm	480.00mm	11-8520	2	13049	2	11-6042	2	.7933 kg		
45-2545-Black	45	45-4545-Black	45.00mm	45.00mm	480.00mm	11-8520	2	13049	2	11-6042	2	.7933 kg		
45-2555	45	45-4545	45.00mm	45.00mm	640.00mm	11-8520	2	13049	2	11-6042	2	1.0358 kg		
45-2555-Black	45	45-4545-Black	45.00mm	45.00mm	640.00mm	11-8520	2	13049	2	11-6042	2	1.0358 kg		
45-2562	45	45-4545-Lite	45.00mm	45.00mm	160.00mm	11-8520	2	13049	2	11-6042	2	.4000 kg		
45-2562-Black	45	45-4545-Lite-Black	45.00mm	45.00mm	160.00mm	11-8520	2	13049	2	11-6042	2	.4000 kg		
45-2561	45	45-4545-Lite	45.00mm	45.00mm	320.00mm	11-8520	2	13049	2	11-6042	2	.4871 kg		
45-2561-Black	45	45-4545-Lite-Black	45.00mm	45.00mm	320.00mm	11-8520	2	13049	2	11-6042	2	.4871 kg		
45-2563	45	45-4545-Lite	45.00mm	45.00mm	480.00mm	11-8520	2	13049	2	11-6042	2	1.0677 kg		
45-2563-Black	45	45-4545-Lite-Black	45.00mm	45.00mm	480.00mm	11-8520	2	13049	2	11-6042	2	1.0677 kg		
45-2564	45	45-4545-Lite	45.00mm	45.00mm	640.00mm	11-8520	2	13049	2	11-6042	2	1.2820 kg		
45-2564-Black	45	45-4545-Lite-Black	45.00mm	45.00mm	640.00mm	11-8520	2	13049	2	11-6042	2	1.2820 kg		
45-2530	45	45-4590	45.00mm	90.00mm	160.00mm	11-8520	4	13049	4	11-6042	4	.7068 kg		
45-2530-Black	45	45-4590-Black	45.00mm	90.00mm	160.00mm	11-8520	4	13049	4	11-6042	4	.7068 kg		
45-2540	45	45-4590	45.00mm	90.00mm	320.00mm	11-8520	4	13049	4	11-6042	4	1.2820 kg		
45-2540-Black	45	45-4590-Black	45.00mm	90.00mm	320.00mm	11-8520	4	13049	4	11-6042	4	1.2820 kg		
45-2550	45	45-4590	45.00mm	90.00mm	480.00mm	11-8520	4	13049	4	11-6042	4	1.8572 kg		
45-2550-Black	45	45-4590-Black	45.00mm	90.00mm	480.00mm	11-8520	4	13049	4	11-6042	4	1.8572 kg		
45-2560	45	45-4590	45.00mm	90.00mm	640.00mm	11-8520	4	13049	4	11-6042	4	2.4324 kg		
45-2560-Black	45	45-4590-Black	45.00mm	90.00mm	640.00mm	11-8520	4	13049	4	11-6042	4	2.4324 kg		

View page 227 for dimensional drawing

Part Description:

The 2 hole - straight flat plate is an external fastening method that requires no machining services. It is a durable connection that can be easily repositioned and reused. This flat plate can provide infinite positioning along the profile T-slot, allowing for a large degree of adjustability. It engages the 2-degree drop-lock feature for most profile series when the assembly bolts are tightened to the required torque, creating a strong connection. **Tip:** Pre-load your hardware prior to connecting profiles to simplify your assembly and save time.

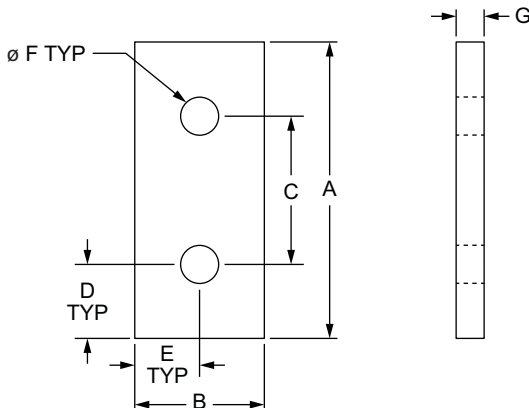

Part No.	Series	Material	Alloy*	Finish	A	B	C	D	E	F	G	Weight
4107	10	Aluminum	6105-T5	Clear Anodize	2.000"	.875"	1.000"	.500"	.438"	.257"	.188"	.029 lb
4107-Black	10			Black Anodize	2.000"	.875"	1.000"	.500"	.438"	.257"	.188"	.029 lb
4307	15			Clear Anodize	3.000"	1.490"	1.500"	.750"	.745"	.328"	.250"	.103 lb
4307-Black	15			Black Anodize	3.000"	1.490"	1.500"	.750"	.745"	.328"	.250"	.103 lb
NEW 20-4107	20			Clear Anodize	40.00mm	18.00mm	20.00mm	10.00mm	9.00mm	5.56mm	4.00mm	.0072 kg
NEW 20-4107-Black	20			Black Anodize	40.00mm	18.00mm	20.00mm	10.00mm	9.00mm	5.56mm	4.00mm	.0072 kg
25-4107	25			Clear Anodize	50.00mm	22.00mm	25.00mm	12.50mm	11.00mm	6.30mm	4.00mm	.0109 kg
25-4107-Black	25			Black Anodize	50.00mm	22.00mm	25.00mm	12.50mm	11.00mm	6.30mm	4.00mm	.0109 kg
30-4307	30			Clear Anodize	60.00mm	27.00mm	30.00mm	15.00mm	13.50mm	6.30mm	4.00mm	.0163 kg
30-4307-Black	30			Black Anodize	60.00mm	27.00mm	30.00mm	15.00mm	13.50mm	6.30mm	4.00mm	.0163 kg
40-4307	40			Clear Anodize	80.00mm	39.80mm	40.00mm	20.00mm	19.90mm	8.30mm	6.00mm	.0490 kg
40-4307-Black	40			Black Anodize	80.00mm	39.80mm	40.00mm	20.00mm	19.90mm	8.30mm	6.00mm	.0490 kg
45-4307	45			Clear Anodize	90.00mm	42.00mm	45.00mm	22.50mm	21.00mm	8.30mm	6.00mm	.0576 kg
45-4307-Black	45			Black Anodize	90.00mm	42.00mm	45.00mm	22.50mm	21.00mm	8.30mm	6.00mm	.0576 kg

* Or comparable

Suggested Hardware (Mount to T-Slot)

Part No.	Series	Qty.	Bolt	T-Nut
3321	10	2	1/4-20 x 1/2" FBHSCS	Economy
3320	15	2	5/16-18 x 11/16" FBHSCS	Economy
75-3656	20	2	M5 x 10mm BHSCS	Economy
75-3404	25	2	M6 x 10mm BHSCS	Economy
75-3600	30	2	M6 x 12mm BHSCS	Drop-in
75-3422	40	2	M8 x 16mm BHSCS	Economy
75-3619	45	2	M8 x 18mm BHSCS	Drop-in

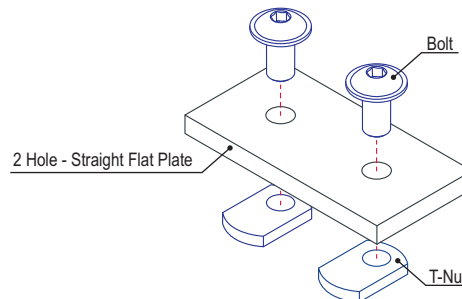

3 Hole - Straight Flat Plate

Part Description:

The 3 hole - straight flat plate is an external fastening method that requires no machining services. It is a durable connection that can be easily repositioned and reused. This flat plate can provide infinite positioning along the profile T-slot, allowing for a large degree of adjustability. It engages the 2-degree drop-lock feature for most profile series when the assembly bolts are tightened to the required torque, creating a strong connection. **Tip:** Use a double slide-in economy T-nut (pg. 364) to save time and money. Pre-load your hardware prior to connecting profiles to simplify your assembly.

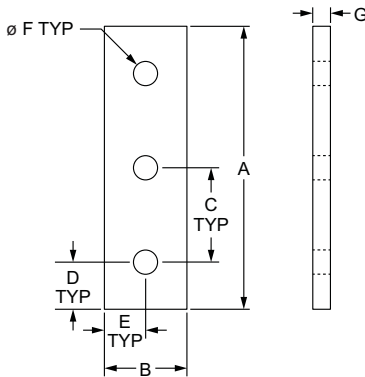

Part No.	Series	Material	Alloy*	Finish	A	B	C	D	E	F	G	Weight
4118	10	Aluminum	6105-T5	Clear Anodize	3.000"	.875"	1.000"	.500"	.438"	.257"	.188"	.044 lb
4118-Black	10			Black Anodize	3.000"	.875"	1.000"	.500"	.438"	.257"	.188"	.044 lb
4306	15			Clear Anodize	4.500"	1.490"	1.500"	.750"	.745"	.328"	.250"	.155 lb
4306-Black	15			Black Anodize	4.500"	1.490"	1.500"	.750"	.745"	.328"	.250"	.155 lb
NEW 20-4118	20			Clear Anodize	60.00mm	18.00mm	20.00mm	10.00mm	9.00mm	5.56mm	4.00mm	.0108 kg
NEW 20-4118-Black	20			Black Anodize	60.00mm	18.00mm	20.00mm	10.00mm	9.00mm	5.56mm	4.00mm	.0108 kg
25-4118	25			Clear Anodize	75.00mm	22.00mm	25.00mm	12.50mm	11.00mm	6.30mm	4.00mm	.0163 kg
25-4118-Black	25			Black Anodize	75.00mm	22.00mm	25.00mm	12.50mm	11.00mm	6.30mm	4.00mm	.0163 kg
30-4306	30			Clear Anodize	90.00mm	27.00mm	30.00mm	15.00mm	13.50mm	6.30mm	4.00mm	.0249 kg
30-4306-Black	30			Black Anodize	90.00mm	27.00mm	30.00mm	15.00mm	13.50mm	6.30mm	4.00mm	.0249 kg
40-4306	40			Clear Anodize	120.00mm	39.80mm	40.00mm	20.00mm	19.90mm	8.30mm	6.00mm	.0730 kg
40-4306-Black	40			Black Anodize	120.00mm	39.80mm	40.00mm	20.00mm	19.90mm	8.30mm	6.00mm	.0730 kg
45-4306	45			Clear Anodize	135.00mm	42.00mm	45.00mm	22.50mm	21.00mm	8.30mm	6.00mm	.0880 kg
45-4306-Black	45			Black Anodize	135.00mm	42.00mm	45.00mm	22.50mm	21.00mm	8.30mm	6.00mm	.0880 kg

* Or comparable

Suggested Hardware (Mount to T-Slot)

Part No.	Series	Qty.	Bolt	T-Nut
3321	10	3	1/4-20 x 1/2" FBHSCS	Economy
3320	15	3	5/16-18 x 11/16" FBHSCS	Economy
75-3656	20	2	M5 x 10mm BHSCS	Economy
75-3404	25	3	M6 x 10mm BHSCS	Economy
75-3600	30	3	M6 x 12mm BHSCS	Drop-in
75-3422	40	3	M8 x 16mm BHSCS	Economy
75-3619	45	3	M8 x 18mm BHSCS	Drop-in

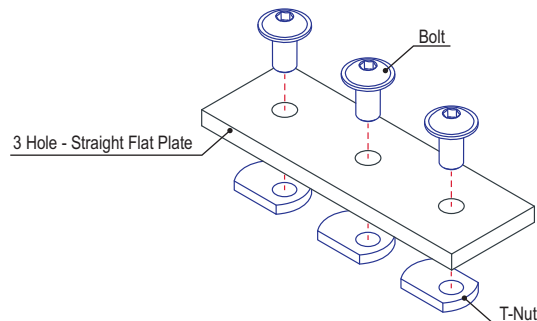

4 Hole - Straight Flat Plate

Part Description:

The 4 hole - straight flat plate is an external fastening method that requires no machining services. It is a durable connection that can be easily repositioned and reused. This flat plate can provide infinite positioning along the profile T-slot, allowing for a large degree of adjustability. It engages the 2-degree drop-lock feature when the assembly bolts are tightened to the required torque, creating a strong connection. **Tip:** Use double or triple slide-in economy T-nuts (pg. 364-365) to save time and money. Pre-load your hardware prior to connecting profiles to simplify your assembly.

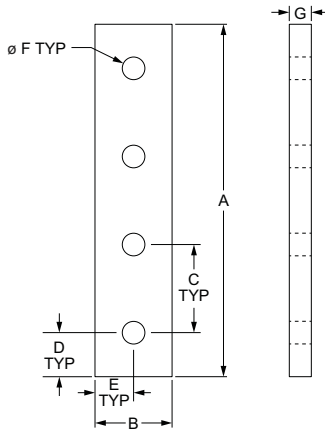

Part No.	Series	Material	Alloy*	Finish	A	B	C	D	E	F	G	Weight
4117	10	Aluminum	6105-T5	Clear Anodize	4.000"	.875"	1.000"	.500"	.438"	.257"	.188"	.058 lb
4117-Black	10			Black Anodize	4.000"	.875"	1.000"	.500"	.438"	.257"	.188"	.058 lb
4305	15			Clear Anodize	6.000"	1.490"	1.500"	.750"	.745"	.328"	.250"	.206 lb
4305-Black	15			Black Anodize	6.000"	1.490"	1.500"	.750"	.745"	.328"	.250"	.206 lb
NEW 20-4117	20			Clear Anodize	80.00mm	18.00mm	20.00mm	10.00mm	9.00mm	5.56mm	4.00mm	.0145 kg
NEW 20-4117-Black	20			Black Anodize	80.00mm	18.00mm	20.00mm	10.00mm	9.00mm	5.56mm	4.00mm	.0145 kg
25-4117	25			Clear Anodize	100.00mm	22.00mm	25.00mm	12.50mm	11.00mm	6.30mm	4.00mm	.0227 kg
25-4117-Black	25			Black Anodize	100.00mm	22.00mm	25.00mm	12.50mm	11.00mm	6.30mm	4.00mm	.0227 kg
NEW 30-4305	30			Clear Anodize	120.00mm	27.00mm	30.00mm	15.00mm	13.50mm	6.81mm	4.00mm	.0332 kg
NEW 30-4305-Black	30			Black Anodize	120.00mm	27.00mm	30.00mm	15.00mm	13.50mm	6.81mm	4.00mm	.0332 kg
40-4305	40			Clear Anodize	160.00mm	39.80mm	40.00mm	20.00mm	19.90mm	8.30mm	6.00mm	.0975 kg
40-4305-Black	40			Black Anodize	160.00mm	39.80mm	40.00mm	20.00mm	19.90mm	8.30mm	6.00mm	.0975 kg
NEW 45-4305	45			Clear Anodize	180.00mm	44.50mm	45.00mm	22.50mm	22.25mm	8.33mm	6.00mm	.1255 kg
NEW 45-4305-Black	45			Black Anodize	180.00mm	44.50mm	45.00mm	22.50mm	22.25mm	8.33mm	6.00mm	.1255 kg

* Or comparable

Suggested Hardware (Mount to T-Slot)

Part No.	Series	Qty.	Bolt	T-Nut
3321	10	4	1/4-20 x 1/2" FBHSCS	Economy
3320	15	4	5/16-18 x 11/16" FBHSCS	Economy
75-3656	20	2	M5 x 10mm BHSCS	Economy
75-3404	25	3	M6 x 10mm BHSCS	Economy
75-3600	30	3	M6 x 12mm BHSCS	Drop-in
75-3422	40	3	M8 x 16mm BHSCS	Economy
75-3619	45	3	M8 x 18mm BHSCS	Drop-in

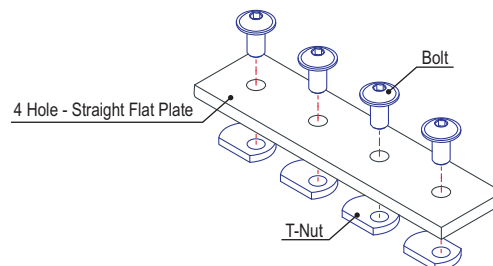

4 Hole - Square Flat Plate

Part Description:

The 4 hole - square flat plate is an external fastening method that requires no machining services. It is a durable connection that can be repositioned and reused. This connection can provide infinite positioning along the profile T-slot, allowing for a large degree of adjustability. The 4 hole - square flat plate engages the 2-degree drop-lock feature when the assembly bolts are tightened to the required torque, creating a strong connection. **Tip:** Use a double slide-in economy T-nut (pg. 364) to save time and money. Pre-load your hardware prior to connecting profiles to simplify your assembly.

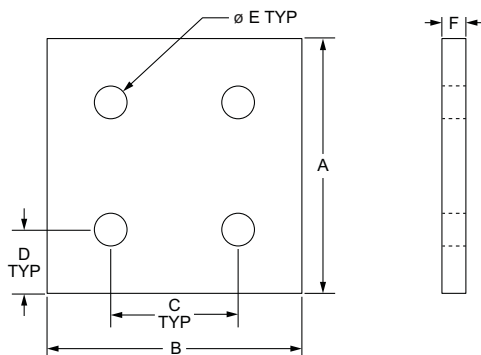

Part No.	Series	Material	Alloy*	Finish	A	B	C	D	E	F	Weight
4167	10	Aluminum	6105-T5	Clear Anodize	2.000"	2.000"	1.000"	.500"	.257"	.188"	.068 lb
4167-Black	10			Black Anodize	2.000"	2.000"	1.000"	.500"	.257"	.188"	.068 lb
4367	15			Clear Anodize	3.000"	3.000"	1.500"	.750"	.328"	.250"	.209 lb
4367-Black	15			Black Anodize	3.000"	3.000"	1.500"	.750"	.328"	.250"	.209 lb
NEW 20-4167	20			Clear Anodize	40.00mm	40.00mm	20.00mm	10.00mm	5.56mm	4.00mm	.0162 kg
NEW 20-4167-Black	20			Black Anodize	40.00mm	40.00mm	20.00mm	10.00mm	5.56mm	4.00mm	.0162 kg
25-4167	25			Clear Anodize	50.00mm	50.00mm	25.00mm	12.50mm	6.30mm	4.00mm	.0252 kg
25-4167-Black	25			Black Anodize	50.00mm	50.00mm	25.00mm	12.50mm	6.30mm	4.00mm	.0252 kg
NEW 30-4367	30			Clear Anodize	60.00mm	60.00mm	30.00mm	15.00mm	6.81mm	4.00mm	.0372 kg
NEW 30-4367-Black	30			Black Anodize	60.00mm	60.00mm	30.00mm	15.00mm	6.81mm	4.00mm	.0372 kg
40-4367	40			Clear Anodize	80.00mm	80.00mm	40.00mm	20.00mm	8.30mm	6.00mm	.0958 kg
40-4367-Black	40			Black Anodize	80.00mm	80.00mm	40.00mm	20.00mm	8.30mm	6.00mm	.0958 kg
NEW 45-4367	45			Clear Anodize	90.00mm	90.00mm	45.00mm	22.50mm	8.33mm	6.00mm	.1273 kg
NEW 45-4367-Black	45			Black Anodize	90.00mm	90.00mm	45.00mm	22.50mm	8.33mm	6.00mm	.1273 kg

* Or comparable

Suggested Hardware (Mount to T-Slot)

Part No.	Series	Qty.	Bolt	T-Nut
3321	10	4	1/4-20 x 1/2" FBHSCS	Economy
3320	15	4	5/16-18 x 11/16" FBHSCS	Economy
75-3656	20	2	M5 x 10mm BHSCS	Economy
75-3404	25	3	M6 x 10mm BHSCS	Economy
75-3600	30	3	M6 x 12mm BHSCS	Drop-in
75-3422	40	3	M8 x 16mm BHSCS	Economy
75-3619	45	3	M8 x 18mm BHSCS	Drop-in

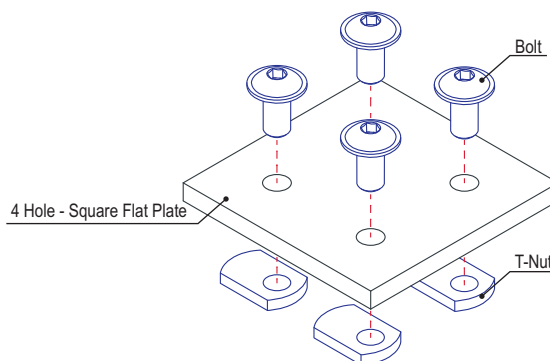

6 Hole - Rectangular Flat Plate

Part Description:

The 6 hole - rectangular flat plate is an external fastening method that requires no machining services. It is a durable connection that can be easily repositioned and reused. The flat plate can provide infinite positioning along the profile T-slot, enabling a large degree of adjustability. When the bolts are tightened to the required torque the 2-degree drop-lock feature is engaged, helping to ensure the strength of the connection. **Tip:** Use double or triple slide-in economy T-nuts (pg. 364-365) to save time and money. Pre-load your hardware prior to connecting profiles to simplify your assembly.

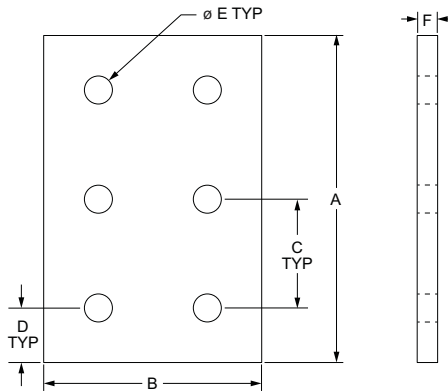

Part No.	Series	Material	Alloy*	Finish	A	B	C	D	E	F	Weight
4166	10	Aluminum	6105-T5	Clear Anodize	3.000"	2.000"	1.000"	.500"	.257"	.188"	.101 lb
4166-Black	10			Black Anodize	3.000"	2.000"	1.000"	.500"	.257"	.188"	.101 lb
4366	15			Clear Anodize	4.500"	3.000"	1.500"	.750"	.328"	.250"	.312 lb
4366-Black	15			Black Anodize	4.500"	3.000"	1.500"	.750"	.328"	.250"	.312 lb
NEW 20-4166	20			Clear Anodize	60.00mm	40.00mm	20.00mm	10.00mm	5.56mm	4.00mm	.0243 kg
NEW 20-4166-Black	20			Black Anodize	60.00mm	40.00mm	20.00mm	10.00mm	5.56mm	4.00mm	.0243 kg
25-4166	25			Clear Anodize	75.00mm	50.00mm	25.00mm	12.50mm	6.30mm	4.00mm	.0376 kg
25-4166-Black	25			Black Anodize	75.00mm	50.00mm	25.00mm	12.50mm	6.30mm	4.00mm	.0376 kg
NEW 30-4366	30			Clear Anodize	90.00mm	60.00mm	30.00mm	15.00mm	6.81mm	4.00mm	.0558 kg
NEW 30-4366-Black	30			Black Anodize	90.00mm	60.00mm	30.00mm	15.00mm	6.81mm	4.00mm	.0558 kg
40-4366	40			Clear Anodize	120.00mm	80.00mm	40.00mm	20.00mm	8.30mm	6.00mm	.1438 kg
40-4366-Black	40			Black Anodize	120.00mm	80.00mm	40.00mm	20.00mm	8.30mm	6.00mm	.1438 kg
NEW 45-4366	45			Clear Anodize	135.00mm	90.00mm	45.00mm	22.50mm	8.33mm	6.00mm	.1909 kg
NEW 45-4366-Black	45			Black Anodize	135.00mm	90.00mm	45.00mm	22.50mm	8.33mm	6.00mm	.1909 kg

* Or comparable

Suggested Hardware (Mount to T-Slot)

Part No.	Series	Qty.	Bolt	T-Nut
3321	10	6	1/4-20 x 1/2" FBHSCS	Economy
3320	15	6	5/16-18 x 11/16" FBHSCS	Economy
75-3656	20	2	M5 x 10mm BHSCS	Economy
75-3404	25	3	M6 x 10mm BHSCS	Economy
75-3600	30	3	M6 x 12mm BHSCS	Drop-in
75-3422	40	3	M8 x 16mm BHSCS	Economy
75-3619	45	3	M8 x 18mm BHSCS	Drop-in

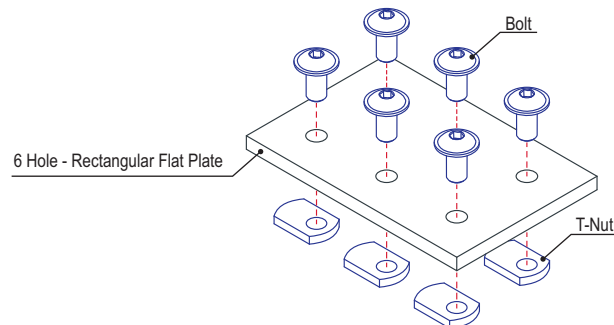

8 Hole - Rectangular Flat Plate

Part Description:

The 8 hole - rectangular flat plate is an external fastening method that requires no machining services. It is a durable connection that can be easily repositioned and reused. The flat plate can provide infinite positioning along the profile T-slot, enabling a large degree of adjustability. When the bolts are tightened to the required torque the 2-degree drop-lock feature is engaged, helping to ensure the strength of the connection. **Tip:** Use double or triple slide-in economy T-nuts (pg. 364-365) to save time and money. Pre-load your hardware prior to connecting profiles to simplify your assembly.

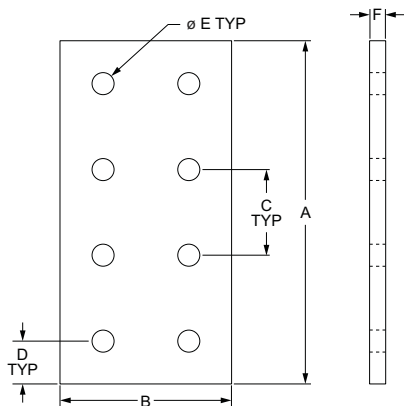

Part No.	Series	Material	Alloy*	Finish	A	B	C	D	E	F	Weight
4165	10	Aluminum	6105-T5	Clear Anodize	4.000"	2.000"	1.000"	.500"	.257"	.188"	.136 lb
4165-Black	10			Black Anodize	4.000"	2.000"	1.000"	.500"	.257"	.188"	.136 lb
4365	15			Clear Anodize	6.000"	3.000"	1.500"	.750"	.328"	.250"	.414 lb
4365-Black	15			Black Anodize	6.000"	3.000"	1.500"	.750"	.328"	.250"	.414 lb
NEW 20-4165	20			Clear Anodize	80.00mm	40.00mm	20.00mm	10.00mm	5.56mm	4.00mm	.0324 kg
NEW 20-4165-Black	20			Black Anodize	80.00mm	40.00mm	20.00mm	10.00mm	5.56mm	4.00mm	.0324 kg
25-4165	25			Clear Anodize	100.00mm	50.00mm	25.00mm	12.50mm	6.30mm	4.00mm	.0494 kg
25-4165-Black	25			Black Anodize	100.00mm	50.00mm	25.00mm	12.50mm	6.30mm	4.00mm	.0494 kg
NEW 30-4365	30			Clear Anodize	120.00mm	60.00mm	30.00mm	15.00mm	6.81mm	4.00mm	.0744 kg
NEW 30-4365-Black	30			Black Anodize	120.00mm	60.00mm	30.00mm	15.00mm	6.81mm	4.00mm	.0744 kg
40-4365	40			Clear Anodize	160.00mm	80.00mm	40.00mm	20.00mm	8.30mm	6.00mm	.1919 kg
40-4365-Black	40			Black Anodize	160.00mm	80.00mm	40.00mm	20.00mm	8.30mm	6.00mm	.1919 kg
NEW 45-4365	45			Clear Anodize	180.00mm	90.00mm	45.00mm	22.50mm	8.33mm	6.00mm	.2546 kg
NEW 45-4365-Black	45			Black Anodize	180.00mm	90.00mm	45.00mm	22.50mm	8.33mm	6.00mm	.2546 kg

* Or comparable

Suggested Hardware (Mount to T-Slot)

Part No.	Series	Qty.	Bolt	T-Nut
3321	10	8	1/4-20 x 1/2" FBHSCS	Economy
3320	15	8	5/16-18 x 11/16" FBHSCS	Economy
75-3656	20	2	M5 x 10mm BHSCS	Economy
75-3404	25	3	M6 x 10mm BHSCS	Economy
75-3600	30	3	M6 x 12mm BHSCS	Drop-in
75-3422	40	3	M8 x 16mm BHSCS	Economy
75-3619	45	3	M8 x 18mm BHSCS	Drop-in

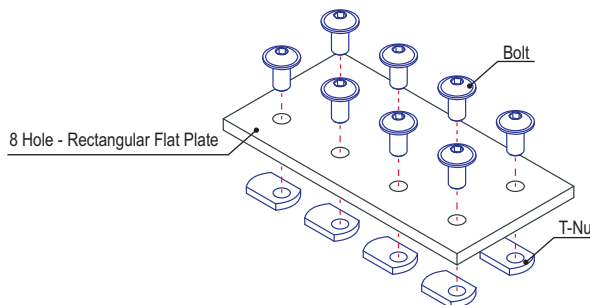

Part Description:

The 2 hole - straight transition flat plate connects profiles within the same product type (either fractional or metric) but of differing series. It is an external fastening method that requires no machining services. This option is reconfigurable and reusable and can provide infinite positioning along the profile T-slot, allowing for a large degree of adjustability. **Tip:** Pre-load your hardware prior to connecting profiles to simplify your assembly and save time.

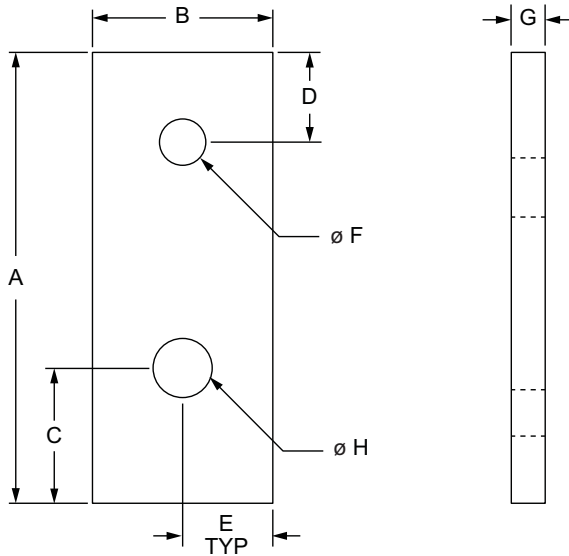

Part No.	Series	Material	Alloy*	Finish	A	B	C	D	E	F	G	H	Weight
4510	10 to 15	Aluminum	6105-T5	Clear Anodize	2.500"	1.000"	.750"	.500"	.500"	.257"	.188"	.328"	.043 lb
4510-Black	10 to 15			Black Anodize	2.500"	1.000"	.750"	.500"	.500"	.257"	.188"	.328"	.043 lb
65-4510	25 to 40			Clear Anodize	65.00mm	25.00mm	20.00mm	12.50mm	12.50mm	6.30mm	4.00mm	8.30mm	.0158 kg
65-4510-Black	25 to 40			Black Anodize	65.00mm	25.00mm	20.00mm	12.50mm	12.50mm	6.30mm	4.00mm	8.30mm	.0163 kg

* Or comparable

Suggested Hardware (Mount to T-Slot)

Part No.	Series	Qty.	Bolt	T-Nut
3321	10 to 15	1	1/4-20 x 1/2" FBHSCS	Economy
3435		1	5/16-18 x 5/8" BHSCS, Washer	Economy
75-3404	25 to 40	1	M6 x 10mm BHSCS	Economy
75-3422		1	M8 x 16mm BHSCS	Economy

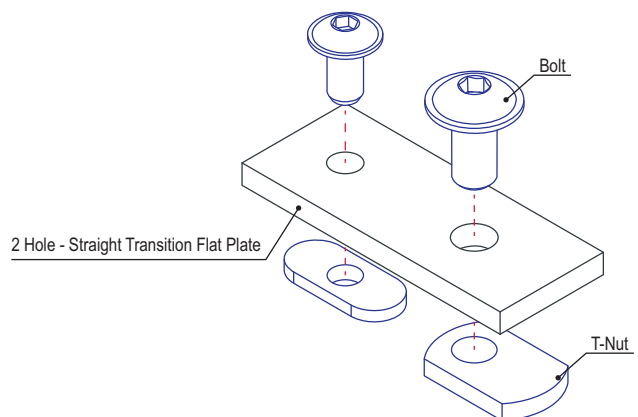

2 Hole - Straight Transition Flat Plate with Flush Offset

Part Description:

The 2 hole - straight transition flat plate with flush offset is an external fastening method that connects profiles within the same product type (either fractional or metric) but of differing series. The offset design creates a flush connection between the different sized profiles. It is a durable connection that is reconfigurable and reusable and can provide infinite positioning along the profile T-slot. **Tip:** Pre-load your hardware prior to connecting profiles to simplify your assembly and save time.

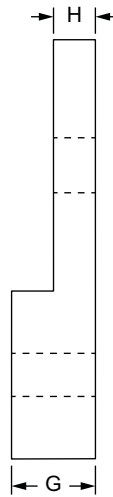
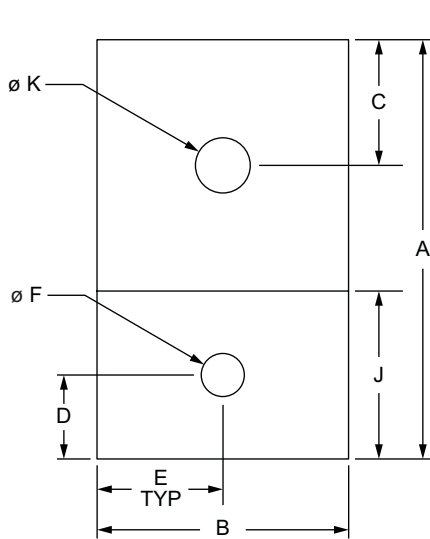

Part No.	Series	Material	Alloy*	Finish	A	B	C	D	E	F	G	H	J	K	Weight
4521	10 to 15	Aluminum	6105-T5	Clear Anodize	2.500"	1.500"	.750"	.500"	.750"	.257"	.500"	.250"	1.000"	.328"	.122 lb
4521-Black	10 to 15			Black Anodize	2.500"	1.500"	.750"	.500"	.750"	.257"	.500"	.250"	1.000"	.328"	.122 lb

* Or comparable

Suggested Hardware (Mount to T-Slot)

Part No.	Series	Qty.	Bolt	T-Nut
3384	10 to 15	1	1/4-20 x 3/4" FBHSCS	Economy
3320		1	5/16-18 x 1 1/16" FBHSCS	Economy

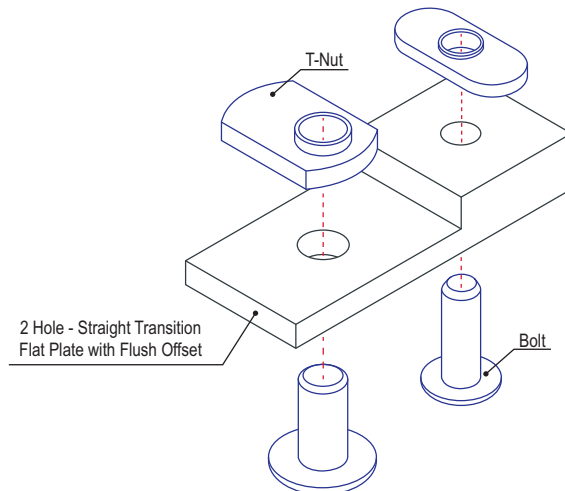

80/20® 2 Hole - Straight Slotted Transition Flat Plate with Flush Offset

Part Description:

The 2 hole - straight slotted transition flat plate with flush offset is an external fastening method that connects profiles within the same product type (either fractional or metric) but of differing series. One of the bolt holes is slotted, as opposed to circular, to allow for an added degree of adjustability when lining up profiles. The offset design creates a flush connection between the different sized profiles. It is a durable connection that is reconfigurable and reusable and can provide infinite positioning along the profile T-slot. **Tip:** Pre-load your hardware prior to connecting profiles to simplify your assembly and save time.

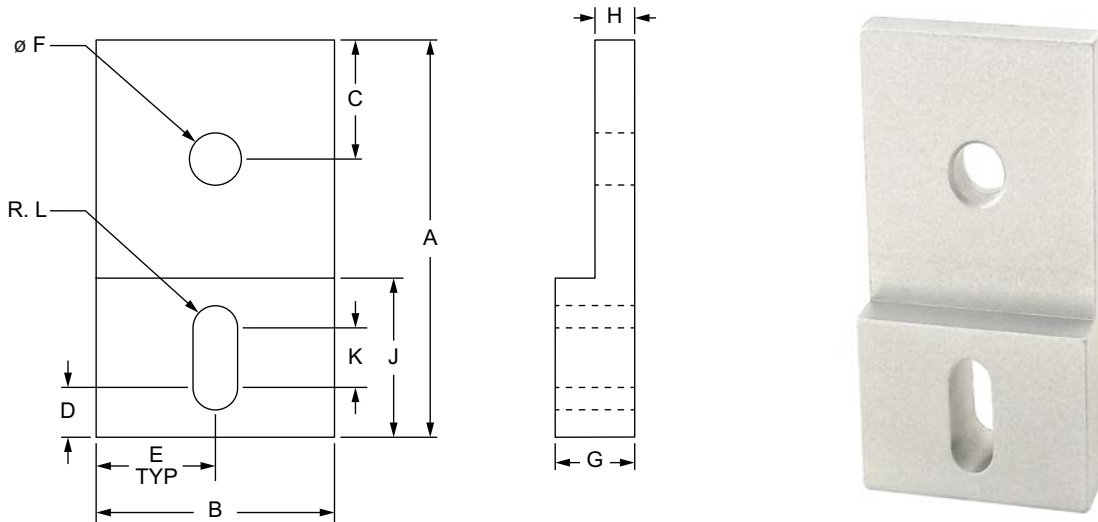

Part No.	Series	Material	Alloy*	Finish	A	B	C	D	E	F	G	H	J	K	L	Weight
4522	10 to 15	Aluminum	6105-T5	Clear Anodize	2.500"	1.500"	.750"	.312"	.750"	.328"	.500"	.250"	1.000"	.375"	.141"	.117 lb
4522-Black	10 to 15			Black Anodize	2.500"	1.500"	.750"	.312"	.750"	.328"	.500"	.250"	1.000"	.375"	.141"	.117 lb

* Or comparable

Suggested Hardware (Mount to T-Slot)

Part No.	Series	Qty.	Bolt	T-Nut
3384	10 to 15	1	1/4-20 x 3/4" FBHSCS	Economy
3320		1	5/16-18 x 11/16" FBHSCS	Economy

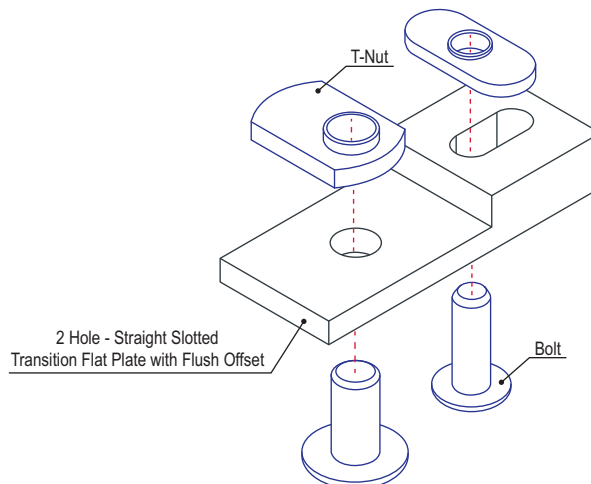

3 Hole - Straight Transition Flat Plate Small Series Primary

Part Description:

The 3 hole - straight transition flat plate small series primary connects profiles within the same product type (either fractional or metric) but of differing series. It is an external fastening method that requires no machining services. This option is reconfigurable and reusable and can provide infinite positioning along the profile T-slot, allowing for a large degree of adjustability. **Tip:** Use a double slide-in economy T-nut (pg. 364) to save time and money. Pre-load your hardware prior to connecting profiles to simplify your assembly.

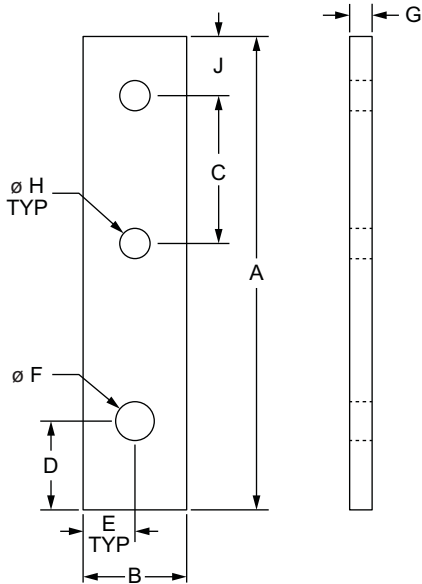

Part No.	Series	Material	Alloy*	Finish	A	B	C	D	E	F	G	H (Qty.)	J	Weight
4506	10 to 15	Aluminum	6105-T5	Clear Anodize	4.000"	.875"	1.250"	.750"	.438"	.328"	.250"	.257" (2)	.500"	.078 lb
4506-Black	10 to 15			Black Anodize	4.000"	.875"	1.250"	.750"	.438"	.328"	.250"	.257" (2)	.500"	.078 lb
65-4506	25 to 40			Clear Anodize	90.00mm	22.00mm	25.50mm	20.00mm	11.00mm	8.30mm	6.00mm	6.30mm (2)	12.00mm	.0290 kg
65-4506-Black	25 to 40			Black Anodize	90.00mm	22.00mm	25.50mm	20.00mm	11.00mm	8.30mm	6.00mm	6.30mm (2)	12.00mm	.0290 kg

* Or comparable

Suggested Hardware (Mount to T-Slot)

Part No.	Series	Qty.	Bolt	T-Nut
3321	10 to 15	2	1/4-20 x 1/2" FBHSCS	Economy
3320		1	5/16-18 x 11/16" FBHSCS	Economy
75-3405	25 to 40	2	M6 x 12mm BHSCS	Economy
75-3422		1	M8 x 16mm BHSCS	Economy

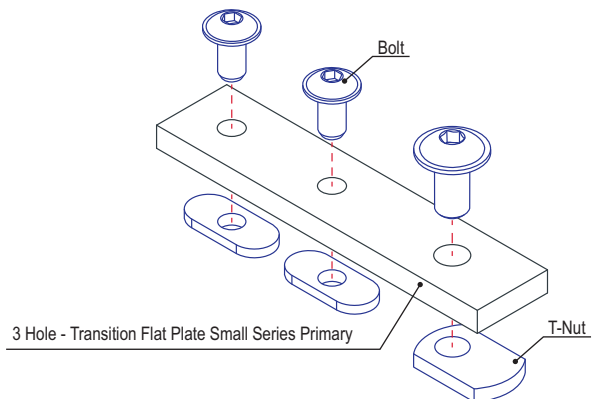



3 Hole - Straight Transition Flat Plate Large Series Primary

Part Description:

The 3 hole - straight transition flat plate large series primary connects profiles within the same product type (either fractional or metric) but of differing series. It is an external fastening method that requires no machining services. This option is reconfigurable and reusable and can provide infinite positioning along the profile T-slot, allowing for a large degree of adjustability. **Tip:** Use a double slide-in economy T-nut (pg. 364) to save time and money. Pre-load your hardware prior to connecting profiles to simplify your assembly.

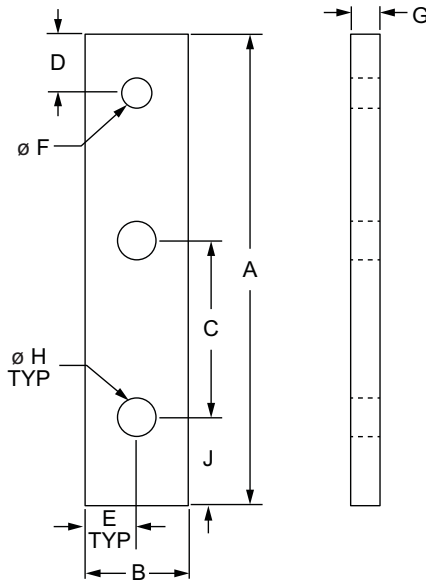

Part No.	Series	Material	Alloy*	Finish	A	B	C	D	E	F	G	H (Qty.)	J	Weight
4505	10 to 15	Aluminum	6105-T5	Clear Anodize	4.000"	.875"	1.500"	.500"	.438"	.257"	.250"	.328" (2)	.750"	.078 lb
4505-Black	10 to 15			Black Anodize	4.000"	.875"	1.500"	.500"	.438"	.257"	.250"	.328" (2)	.750"	.078 lb
65-4505	25 to 40			Clear Anodize	105.00mm	22.00mm	40.00mm	12.50mm	11.00mm	6.30mm	6.00mm	8.30mm (2)	20.00mm	.0331 kg
65-4505-Black	25 to 40			Black Anodize	105.00mm	22.00mm	40.00mm	12.50mm	11.00mm	6.30mm	6.00mm	8.30mm (2)	20.00mm	.0331 kg

* Or comparable

Suggested Hardware (Mount to T-Slot)

Part No.	Series	Qty.	Bolt	T-Nut
3321	10 to 15	1	1/4-20 x 1/2" FBHSCS	Economy
3320		2	5/16-18 x 11/16" FBHSCS	Economy
75-3405	25 to 40	1	M6 x 12mm BHSCS	Economy
75-3422		2	M8 x 16mm BHSCS	Economy

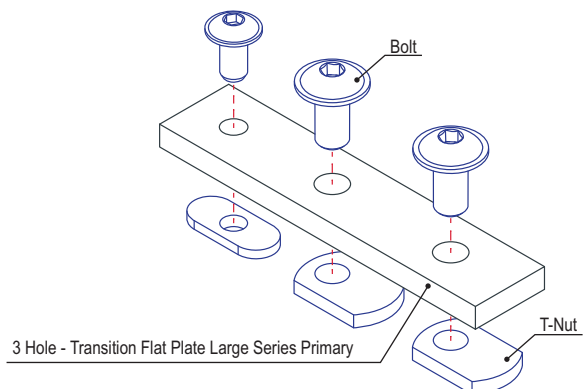

4 Hole - Straight Transition Flat Plate

Part Description:

The 4 hole - straight transition flat plate connects profiles within the same product type (either fractional or metric) but of differing series. It is an external fastening method that requires no machining services. This option is reconfigurable and reusable and can provide infinite positioning along the profile T-slot, allowing for a large degree of adjustability. **Tip:** Use a double slide-in economy T-nut (pg. 364) to save time and money. Pre-load your hardware prior to connecting profiles to simplify your assembly.

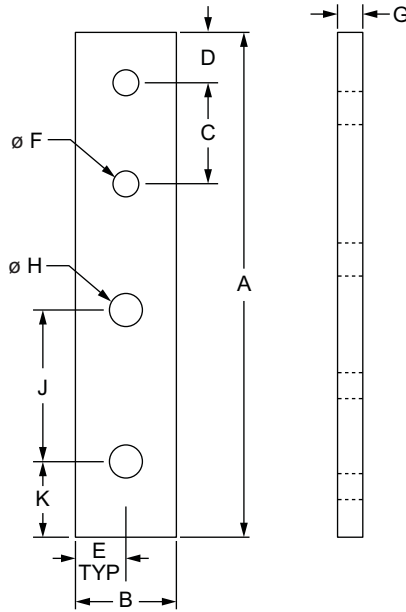

Part No.	Series	Material	Alloy*	Finish	A	B	C	D	E	F (Qty.)	G	H (Qty.)	J	K	Weight
4514	10 to 15	Aluminum	6105-T5	Clear Anodize	5.000"	1.000"	1.000"	.500"	.500"	.257" (2)	.250"	.328" (2)	1.500"	.750"	.114 lb
4514-Black	10 to 15			Black Anodize	5.000"	1.000"	1.000"	.500"	.500"	.257" (2)	.250"	.328" (2)	1.500"	.750"	.114 lb

* Or comparable

Suggested Hardware (Mount to T-Slot)

Part No.	Series	Qty.	Bolt	T-Nut
3321	10 to 15	2	1/4-20 x 1/2" FBHSCS	Economy
3320		2	5/16-18 x 11/16" FBHSCS	Economy

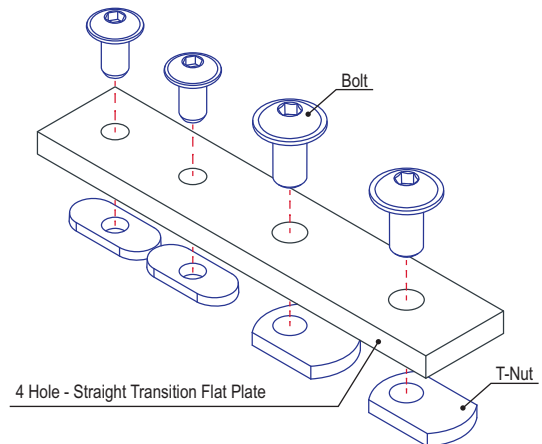



Part Description:

The 4 hole - rectangular transition flat plate connects profiles within the same product type (either fractional or metric) but of differing series. It is an external fastening method that requires no machining services. This option is reconfigurable and reusable and can provide infinite positioning along the profile T-slot, allowing for a large degree of adjustability. **Tip:** Use a double slide-in economy T-nut (pg. 364) to save time and money. Pre-load your hardware prior to connecting profiles to simplify your assembly.

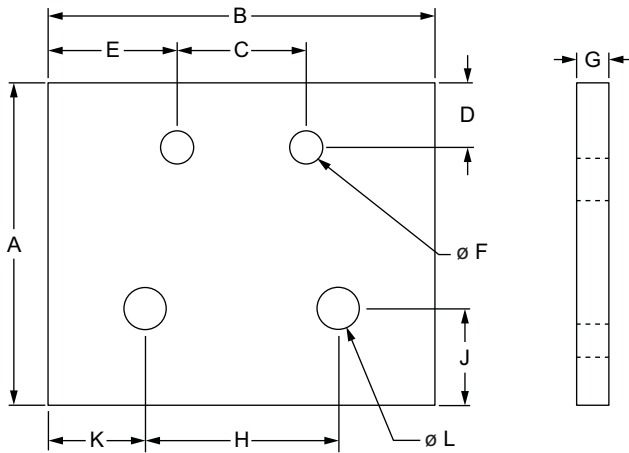

Part No.	Series	Material	Alloy*	Finish	A	B	C	D	E	F (Qty.)	G	H	J	K	L (Qty.)	Weight
4515	10 to 15	Aluminum	6105-T5	Clear Anodize	2.500"	3.000"	1.000"	.500"	1.000"	.257" (2)	.250"	1.500"	.750"	.750"	.328" (2)	.173 lb
4515-Black	10 to 15			Black Anodize	2.500"	3.000"	1.000"	.500"	1.000"	.257" (2)	.250"	1.500"	.750"	.750"	.328" (2)	.173 lb

* Or comparable

Suggested Hardware (Mount to T-Slot)

Part No.	Series	Qty.	Bolt	T-Nut
3321	10 to 15	2	1/4-20 x 1/2" FBHSCS	Economy
3320		2	5/16-18 x 11/16" FBHSCS	Economy

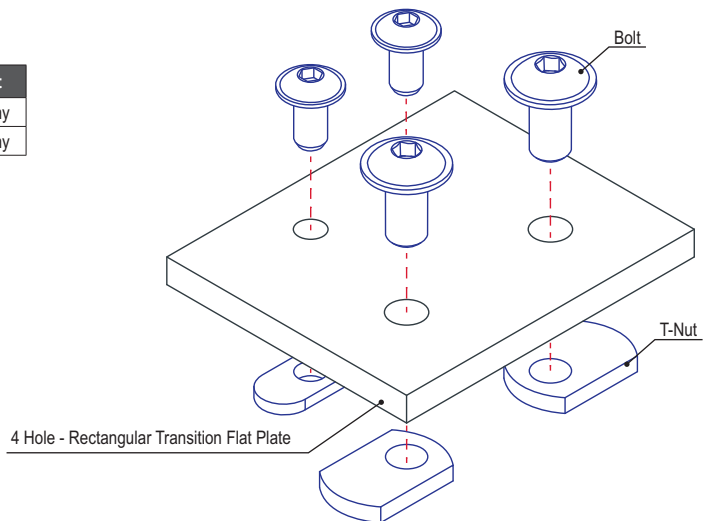

4 Hole - Rectangular Transition Flat Plate with Flush Offset

Part Description:

The 4 hole - rectangular transition flat plate with flush offset is an external fastening method that connects profiles within the same product type (either fractional or metric) but of differing series. One of the bolt holes is slotted, as opposed to circular, to allow for an added degree of adjustability when lining up profiles. The offset design creates a flush connection between the different sized profiles. It is a durable connection that is reconfigurable and reusable and can provide infinite positioning along the profile T-slot. **Tip:** Use a double slide-in economy T-nut (pg. 364) to save time and money. Pre-load your hardware prior to connecting profiles to simplify your assembly.

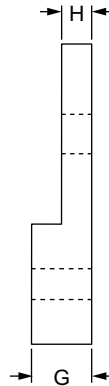
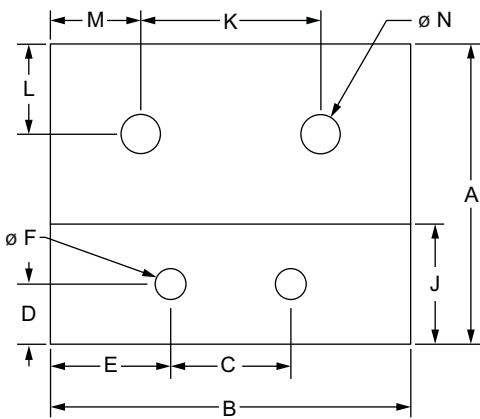

Part No.	Series	Color	A	B	C	D	E	F (Qty.)	G	H	J	K	L	M	N	Weight
4523	10 to 15	Clear	2.500"	3.000"	1.000"	.500"	1.000"	.257" (2)	.500"	.250"	1.000"	1.500"	.750"	.750"	.328"	.243 lb
4523-Black	10 to 15	Black	2.500"	3.000"	1.000"	.500"	1.000"	.257" (2)	.500"	.250"	1.000"	1.500"	.750"	.750"	.328"	.243 lb

Material Specifications

Material	Alloy*	Finish
Aluminum	6105-T5	Anodize

* Or comparable

Suggested Hardware (Mount to T-Slot)

Part No.	Series	Qty.	Bolt	T-Nut
3384		2	1/4-20 x 3/4" FBHSCS	Economy
3320	10 to 15	2	5/16-18 x 11/16" FBHSCS	Economy

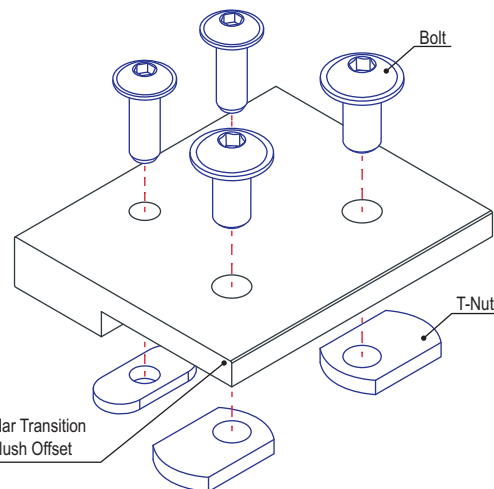

4 Hole - Rectangular Transition Flat Plate with Flush Offset

FASTENERS



4 Hole - Rectangular Slotted Transition Flat Plate with Flush Offset

Part Description:

The 4 hole - rectangular slotted transition flat plate with flush offset is an external fastening method that connects profiles within the same product type (either fractional or metric) but of differing series. One of the bolt holes is slotted, as opposed to circular, to allow for an added degree of adjustability when lining up profiles. The offset design creates a flush connection between the different sized profiles. It is a durable connection that is reconfigurable and reusable and can provide infinite positioning along the profile T-slot.

Tip: Use a double slide-in economy T-nut (pg. 364) to save time and money. Pre-load your hardware prior to connecting profiles to simplify your assembly.

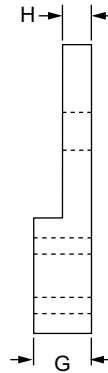
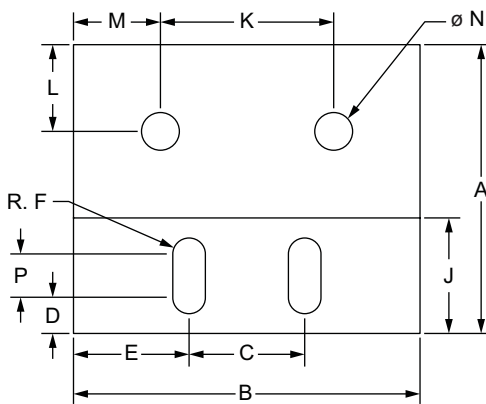

Part No.	Series	Color	A	B	C	D	E	F (Qty.)	G	H	J	K	L	M	N (Qty.)	P	Weight
4524	10 to 15	Clear	2.500"	3.000"	1.000"	.312"	1.000"	.141" (2)	.500"	.250"	1.000"	1.500"	.750"	.750"	.328" (2)	.375"	.239 lb
4524-Black	10 to 15	Black	2.500"	3.000"	1.000"	.312"	1.000"	.141" (2)	.500"	.250"	1.000"	1.500"	.750"	.750"	.328" (2)	.375"	.239 lb

Material Specifications

Material	Alloy*	Finish
Aluminum	6105-T5	Anodize

* Or comparable

Suggested Hardware (Mount to T-Slot)

Part No.	Series	Qty.	Bolt	T-Nut
3384	10 to 15	2	1/4-20 x 3/4" FBHSCS	Economy
3320		2	5/16-18 x 11/16" FBHSCS	Economy

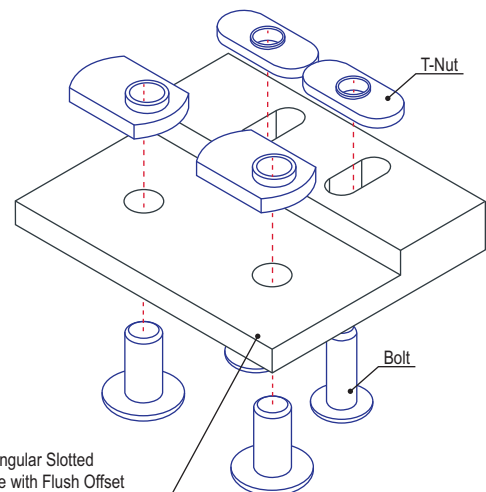

4 Hole - Rectangular Slotted Transition Flat Plate with Flush Offset

6 Hole - Rectangular Transition Flat Plate Small Series Primary

Part Description:

The 6 hole - rectangular transition flat plate small series primarily connects profiles within the same product type (either fractional or metric) but of differing series. It is an external fastening method that requires no machining services. This option is reconfigurable and reusable and can provide infinite positioning along the profile T-slot, allowing for a large degree of adjustability. **Tip:** Use a double slide-in economy T-nut (pg. 364) to save time and money. Pre-load your hardware prior to connecting profiles to simplify your assembly.

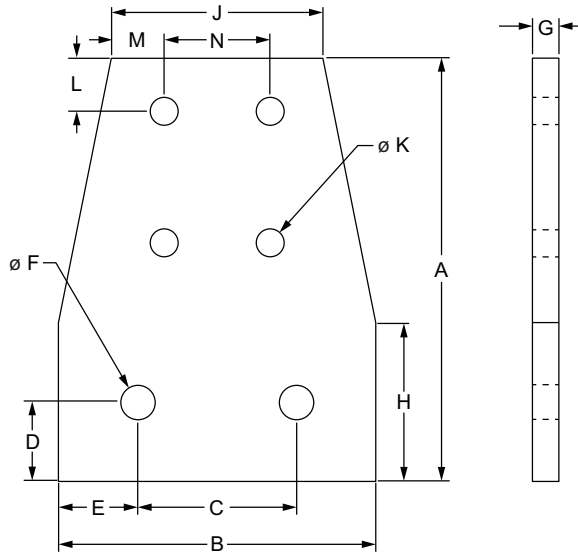

Part No.	Series	Color	A	B	C	D	E	F (Qty.)	G	H	J	K (Qty.)	L	M	N	Weight
4519	10 to 15	Clear	4.000"	3.000"	1.500"	.750"	.750"	.328" (2)	.250"	1.500"	2.000"	.257" (4)	.500"	.500"	1.000"	.250 lb
4519-Black	10 to 15	Black	4.000"	3.000"	1.500"	.750"	.750"	.328" (2)	.250"	1.500"	2.000"	.257" (4)	.500"	.500"	1.000"	.250 lb

Material Specifications

Material	Alloy*	Finish
Aluminum	6105-T5	Anodize

* Or comparable

Suggested Hardware (Mount to T-Slot)

Part No.	Series	Qty.	Bolt	T-Nut
3321	10 to 15	4	1/4-20 x 1/2" FBHSCS	Economy
3320		2	5/16-18 x 11/16" FBHSCS	Economy

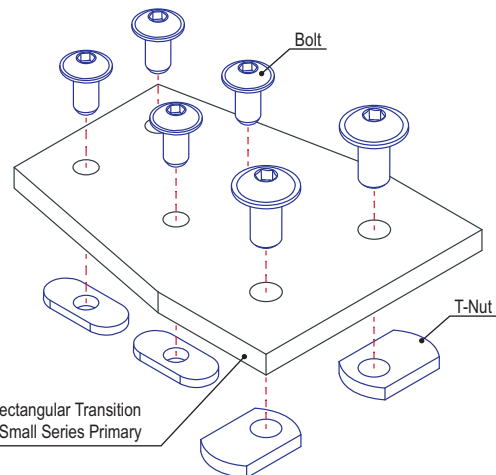

6 Hole - Rectangular Transition Flat Plate Small Series Primary



6 Hole - Rectangular Transition Flat Plate Large Series Primary

Part Description:

The 6 hole - rectangular transition flat plate large series primarily connects profiles within the same product type (either fractional or metric) but of differing series. It is an external fastening method that requires no machining services. This option is reconfigurable and reusable and can provide infinite positioning along the profile T-slot, allowing for a large degree of adjustability. **Tip:** Use a double slide-in economy T-nut (pg. 364) to save time and money. Pre-load your hardware prior to connecting profiles to simplify your assembly.

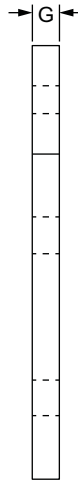
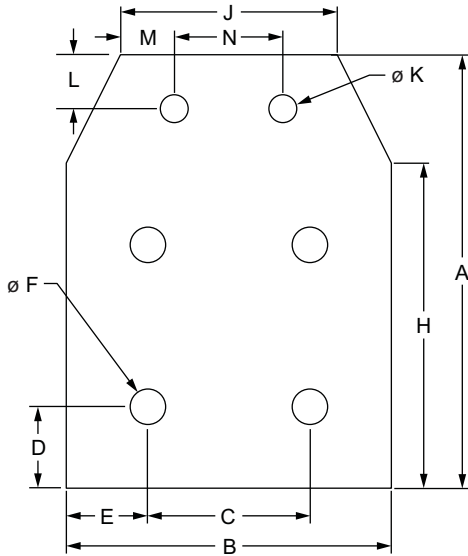

Part No.	Series	Color	A	B	C	D	E	F (Qty.)	G	H	J	K (Qty.)	L	M	N	Weight
4520	10 to 15	Clear	4.000"	3.000"	1.500"	.750"	.750"	.328" (4)	.250"	3.000"	2.000"	.257" (2)	.500"	.500"	1.000"	.264 lb
4520-Black	10 to 15	Black	4.000"	3.000"	1.500"	.750"	.750"	.328" (4)	.250"	3.000"	2.000"	.257" (2)	.500"	.500"	1.000"	.264 lb

Material Specifications

Material	Alloy*	Finish
Aluminum	6105-T5	Anodize

* Or comparable

Suggested Hardware (Mount to T-Slot)

Part No.	Series	Qty.	Bolt	T-Nut
3321	10 to 15	2	1/4-20 x 1/2" FBHSCS	Economy
3320		4	5/16-18 x 11/16" FBHSCS	Economy

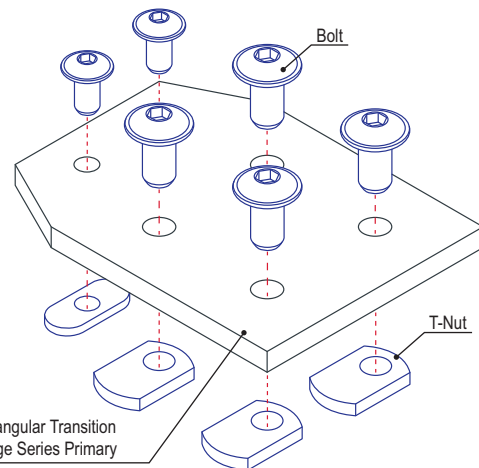

6 Hole - Rectangular Transition Flat Plate Large Series Primary

8 Hole - Rectangular Transition Flat Plate

Part Description:

The 8 hole - rectangular transition flat plate connects profiles within the same product type (either fractional or metric) but of differing series. It is an external fastening method that requires no machining services. This option is reconfigurable and reusable and can provide infinite positioning along the profile T-slot, allowing for a large degree of adjustability. **Tip:** Use a double slide-in economy T-nut (pg. 364) to save time and money. Pre-load your hardware prior to connecting profiles to simplify your assembly.

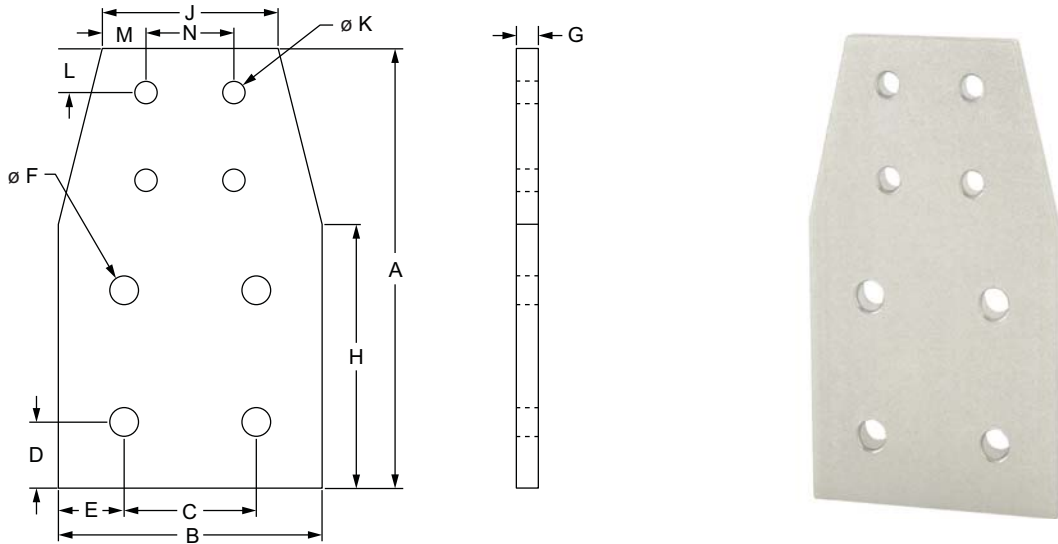

Part No.	Series	Color	A	B	C	D	E	F (Qty.)	G	H	J	K (Qty.)	L	M	N	Weight
4518	10 to 15	Clear	5.000"	3.000"	1.500"	.750"	.750"	.328" (4)	.250"	3.000"	2.000"	.257" (4)	.500"	.500"	1.000"	.327 lb
4518-Black	10 to 15	Black	5.000"	3.000"	1.500"	.750"	.750"	.328" (4)	.250"	3.000"	2.000"	.257" (4)	.500"	.500"	1.000"	.327 lb

Material Specifications

Material	Alloy*	Finish
Aluminum	6105-T5	Anodize

* Or comparable

Suggested Hardware (Mount to T-Slot)

Part No.	Series	Qty.	Bolt	T-Nut
3321	10 to 15	4	1/4-20 x 1/2" FBHSCS	Economy
3320		4	5/16-18 x 11/16" FBHSCS	Economy

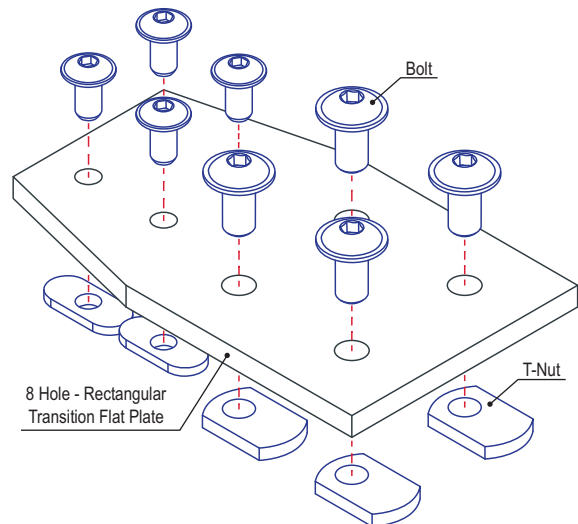

FASTENERS



Part Description:

The 4 hole - 90 degree angled flat plate is an external fastening method that requires no machining services. This flat plate creates a 90 degree angle between profiles and its shape reinforces the strength of the connection. It is a durable option that is easy to assemble and can be reconfigured and reused. **Tip:** Use double or triple slide-in economy T-nuts (pg. 364-365) to save time and money. Pre-load your hardware prior to connecting profiles to simplify your assembly.

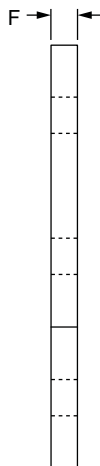
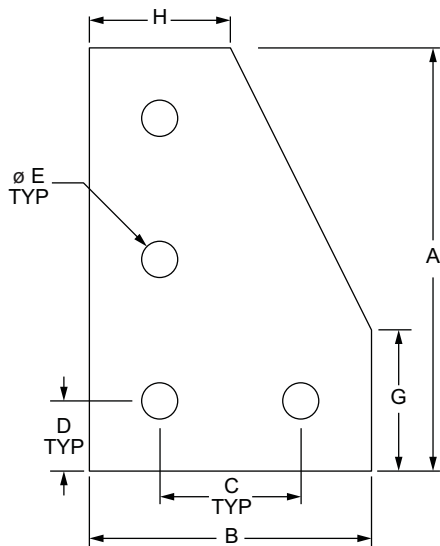

Part No.	Series	Material	Alloy*	Finish	A	B	C	D	E	F	G	H	Weight
4150	10	Aluminum	6105-T5	Clear Anodize	3.000"	2.000"	1.000"	.500"	.257"	.188"	1.000"	1.000"	.087 lb
4150-Black	10			Black Anodize	3.000"	2.000"	1.000"	.500"	.257"	.188"	1.000"	1.000"	.087 lb
4350	15			Clear Anodize	4.500"	3.000"	1.500"	.750"	.328"	.250"	1.500"	1.500"	.264 lb
4350-Black	15			Black Anodize	4.500"	3.000"	1.500"	.750"	.328"	.250"	1.500"	1.500"	.264 lb
25-4150	25			Clear Anodize	75.00mm	50.00mm	25.00mm	12.50mm	6.20mm	4.00mm	25.00mm	25.00mm	.0318 kg
25-4150-Black	25			Black Anodize	75.00mm	50.00mm	25.00mm	12.50mm	6.20mm	4.00mm	25.00mm	25.00mm	.0318 kg
40-4350	40			Clear Anodize	120.00mm	80.00mm	40.00mm	20.00mm	8.30mm	6.00mm	40.00mm	40.00mm	.1207 kg
40-4350-Black	40			Black Anodize	120.00mm	80.00mm	40.00mm	20.00mm	8.30mm	6.00mm	40.00mm	40.00mm	.1207 kg

* Or comparable

Suggested Hardware (Mount to T-Slot)

Part No.	Series	Qty.	Bolt	T-Nut
3321	10	4	1/4-20 x 1/2" FBHSCS	Economy
3320	15	4	5/16-18 x 11/16" FBHSCS	Economy
75-3404	25	4	M6 x 10mm BHSCS	Economy
75-3422	40	4	M8 x 16mm BHSCS	Economy

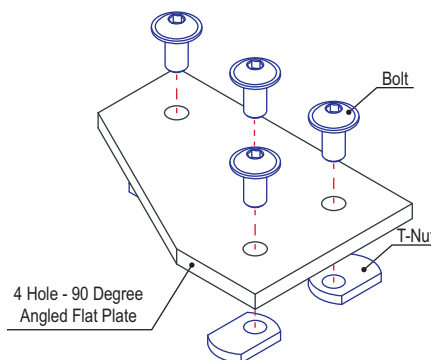

5 Hole - 90 Degree Angled Flat Plate



Part Description:

The 5 hole - 90 degree angled flat plate is an external fastening method that requires no machining services. This flat plate creates a 90 degree angle between profiles and its shape reinforces the strength of the connection. It is a durable option that is easy to assemble and can be reconfigured and reused. **Tip:** Use double or triple slide-in economy T-nuts (pg. 364-365) to save time and money. Pre-load your hardware prior to connecting profiles to simplify your assembly.

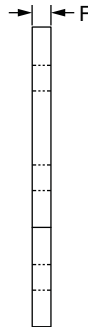
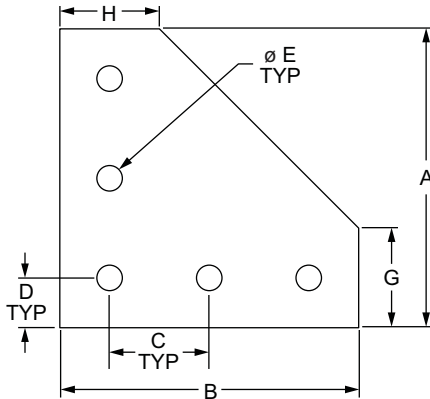

FASTENERS

Part No.	Series	Material	Alloy*	Finish	A	B	C	D	E	F	G	H	Weight
4151	10	Aluminum	6105-T5	Clear Anodize	3.000"	3.000"	1.000"	.500"	.257"	.188"	1.000"	1.000"	.119 lb
4151-Black	10			Black Anodize	3.000"	3.000"	1.000"	.500"	.257"	.188"	1.000"	1.000"	.119 lb
4351	15			Clear Anodize	4.500"	4.500"	1.500"	.750"	.328"	.250"	1.500"	1.500"	.363 lb
4351-Black	15			Black Anodize	4.500"	4.500"	1.500"	.750"	.328"	.250"	1.500"	1.500"	.363 lb
25-4151	25			Clear Anodize	75.00mm	75.00mm	25.00mm	12.50mm	6.30mm	4.00mm	25.00mm	25.00mm	.0454 kg
25-4151-Black	25			Black Anodize	75.00mm	75.00mm	25.00mm	12.50mm	6.30mm	4.00mm	25.00mm	25.00mm	.0454 kg
30-4351	30			Clear Anodize	90.00mm	90.00mm	30.00mm	15.00mm	6.30mm	4.00mm	30.00mm	30.00mm	.0644 kg
30-4351-Black	30			Black Anodize	90.00mm	90.00mm	30.00mm	15.00mm	6.30mm	4.00mm	30.00mm	30.00mm	.0644 kg
40-4351	40			Clear Anodize	120.00mm	120.00mm	40.00mm	20.00mm	8.30mm	6.00mm	40.00mm	40.00mm	.1719 kg
40-4351-Black	40			Black Anodize	120.00mm	120.00mm	40.00mm	20.00mm	8.30mm	6.00mm	40.00mm	40.00mm	.1719 kg
45-4351	45			Clear Anodize	135.00mm	135.00mm	45.00mm	22.50mm	8.30mm	6.00mm	45.00mm	45.00mm	.2214 kg
45-4351-Black	45			Black Anodize	135.00mm	135.00mm	45.00mm	22.50mm	8.30mm	6.00mm	45.00mm	45.00mm	.2214 kg

* Or comparable

Suggested Hardware (Mount to T-Slot)

Part No.	Series	Qty.	Bolt	T-Nut
3321	10	5	1/4-20 x 1/2" FBHSCS	Economy
3320	15	5	5/16-18 x 11/16" FBHSCS	Economy
75-3404	25	5	M6 x 10mm BHSCS	Economy
75-3600	30	5	M6 x 12mm BHSCS	Drop-In
75-3422	40	5	M8 x 16mm BHSCS	Economy
75-3619	45	5	M8 x 18mm BHSCS	Drop-In

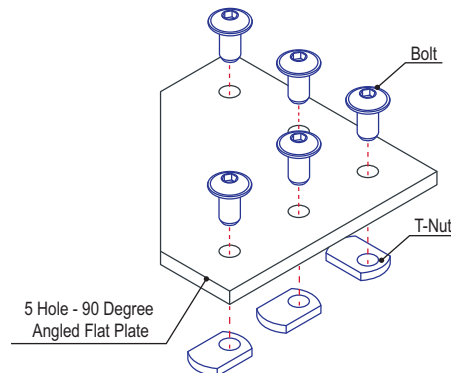



Part Description:

The 6 hole - 90 degree angled stacked flat plate is an external fastening method that requires no machining services. This flat plate creates a 90 degree angle between profiles and its shape reinforces the strength of the connection. It is a durable option that is easy to assemble and can be reconfigured and reused. **Tip:** Use double or triple slide-in economy T-nuts (pg. 364-365) to save time and money. Pre-load your hardware prior to connecting profiles to simplify your assembly.

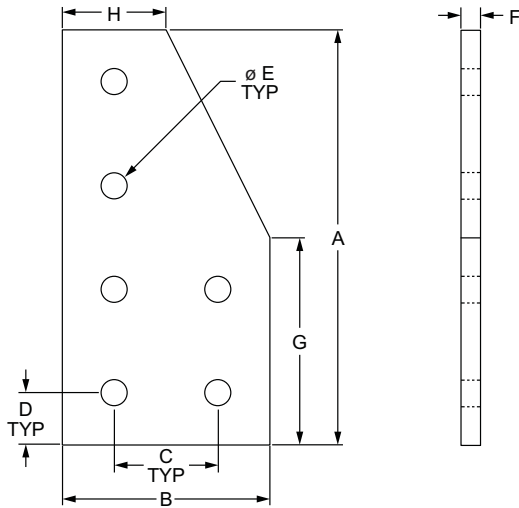

Part No.	Series	Material	Alloy*	Finish	A	B	C	D	E	F	G	H	Weight	
4120	10	Aluminum	6105-T5	Clear Anodize	4.000"	2.000"	1.000"	.500"	.257"	.188"	2.000"	1.000"	.121 lb	
4120-Black	10			Black Anodize	4.000"	2.000"	1.000"	.500"	.257"	.188"	.250"	2.000"	1.000"	.121 lb
4320	15			Clear Anodize	6.000"	3.000"	1.500"	.750"	.328"	.250"	.250"	3.000"	1.500"	.444 lb
4320-Black	15			Black Anodize	6.000"	3.000"	1.500"	.750"	.328"	.250"	.250"	3.000"	1.500"	.444 lb
25-4120	25			Clear Anodize	100.00mm	50.00mm	25.00mm	12.50mm	6.30mm	4.00mm	50.00mm	25.00mm	25.00mm	.0440 kg
25-4120-Black	25			Black Anodize	100.00mm	50.00mm	25.00mm	12.50mm	6.30mm	4.00mm	50.00mm	25.00mm	25.00mm	.0440 kg
40-4320	40			Clear Anodize	160.00mm	80.00mm	40.00mm	20.00mm	8.30mm	6.00mm	80.00mm	40.00mm	40.00mm	.1696 kg
40-4320-Black	40			Black Anodize	160.00mm	80.00mm	40.00mm	20.00mm	8.30mm	6.00mm	80.00mm	40.00mm	40.00mm	.1696 kg

* Or comparable

Suggested Hardware (Mount to T-Slot)

Part No.	Series	Qty.	Bolt	T-Nut
3321	10	6	1/4-20 x 1/2" FBHSCS	Economy
3320	15	6	5/16-18 x 11/16" FBHSCS	Economy
75-3404	25	6	M6 x 10mm BHSCS	Economy
75-3422	40	6	M8 x 16mm BHSCS	Economy

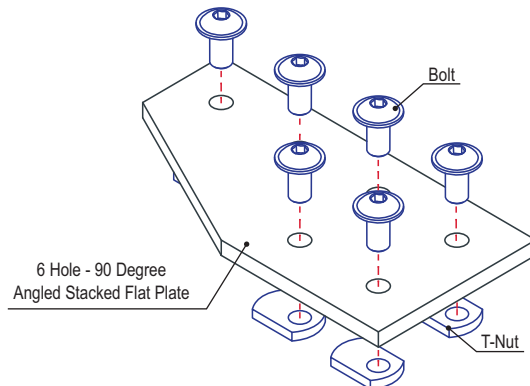

6 Hole - 90 Degree Angled Squared Flat Plate

Part Description:

The 6 hole - 90 degree angled squared flat plate is an external fastening method that requires no machining services. This flat plate creates a 90 degree angle between profiles and its shape reinforces the strength of the connection. It is a durable option that is easy to assemble and can be reconfigured and reused. **Tip:** Use double or triple slide-in economy T-nuts (pg. 364-365) to save time and money. Pre-load your hardware prior to connecting profiles to simplify your assembly.

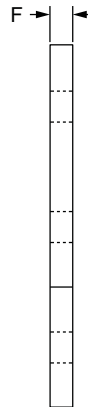
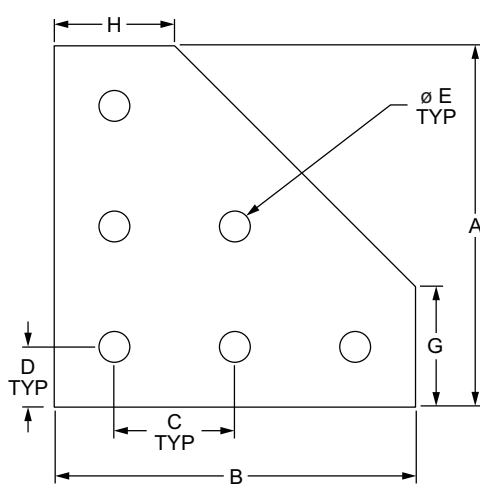

Part No.	Series	Material	Alloy*	Finish	A	B	C	D	E	F	G	H	Weight
4061	10	Aluminum	6105-T5	Clear Anodize	3.000"	3.000"	1.000"	.500"	.257"	.188"	1.000"	1.000"	.117 lb
4061-Black	10			Black Anodize	3.000"	3.000"	1.000"	.500"	.257"	.188"	1.000"	1.000"	.117 lb
4461	15			Clear Anodize	4.500"	4.500"	1.500"	.750"	.328"	.250"	1.500"	1.500"	.361 lb
4461-Black	15			Black Anodize	4.500"	4.500"	1.500"	.750"	.328"	.250"	1.500"	1.500"	.361 lb

* Or comparable

Suggested Hardware (Mount to T-Slot)

Part No.	Series	Qty.	Bolt	T-Nut
3321	10	6	1/4-20 x 1/2" FBHSCS	Economy
3320	15	6	5/16-18 x 11/16" FBHSCS	Economy

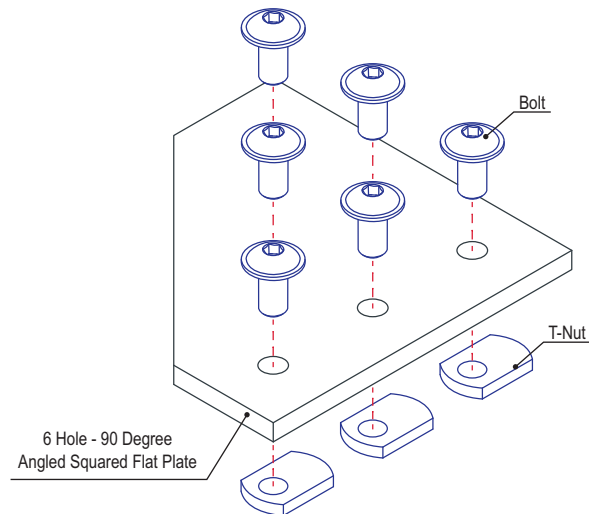



Part Description:

The 7 hole - 90 degree angled squared flat plate is an external fastening method that requires no machining services. This flat plate creates a 90 degree angle between profiles and its shape reinforces the strength of the connection. It is a durable option that is easy to assemble and can be reconfigured and reused. **Tip:** Use double or triple slide-in economy T-nuts (pg. 364-365) to save time and money. Pre-load your hardware prior to connecting profiles to simplify your assembly.

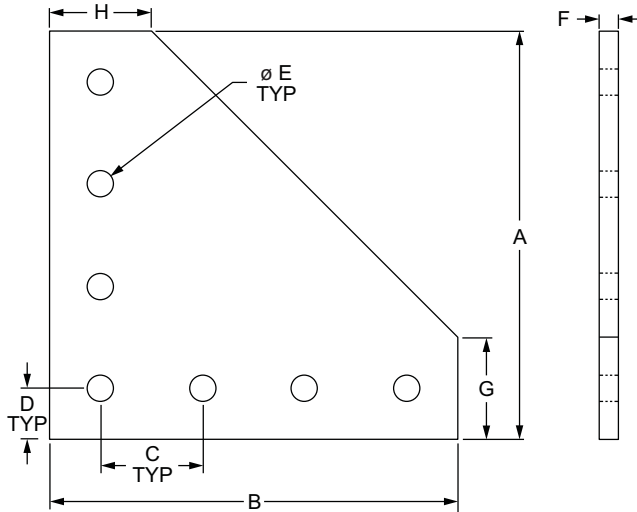

Part No.	Series	Material	Alloy*	Finish	A	B	C	D	E	F	G	H	Weight
4152	10	Aluminum	6105-T5	Clear Anodize	4.000"	4.000"	1.000"	.500"	.257"	.188"	1.000"	1.000"	.199 lb
4152-Black	10			Black Anodize	4.000"	4.000"	1.000"	.500"	.257"	.188"	1.000"	1.000"	.199 lb
4352	15			Clear Anodize	6.000"	6.000"	1.500"	.750"	.328"	.250"	1.500"	1.500"	.622 lb
4352-Black	15			Black Anodize	6.000"	6.000"	1.500"	.750"	.328"	.250"	1.500"	1.500"	.622 lb
25-4152	25			Clear Anodize	100.00mm	100.00mm	25.00mm	12.50mm	6.30mm	4.00mm	25.00mm	25.00mm	.0744 kg
25-4152-Black	25			Black Anodize	100.00mm	100.00mm	25.00mm	12.50mm	6.30mm	4.00mm	25.00mm	25.00mm	.0744 kg
40-4352	40			Clear Anodize	160.00mm	160.00mm	40.00mm	20.00mm	8.30mm	6.00mm	40.00mm	40.00mm	.2886 kg
40-4352-Black	40			Black Anodize	160.00mm	160.00mm	40.00mm	20.00mm	8.30mm	6.00mm	40.00mm	40.00mm	.2886 kg

* Or comparable

Suggested Hardware (Mount to T-Slot)

Part No.	Series	Qty.	Bolt	T-Nut
3321	10	7	1/4-20 x 1/2" FBHSCS	Economy
3320	15	7	5/16-18 x 11/16" FBHSCS	Economy
75-3404	25	7	M6 x 10mm BHSCS	Economy
75-3422	40	7	M8 x 16mm BHSCS	Economy

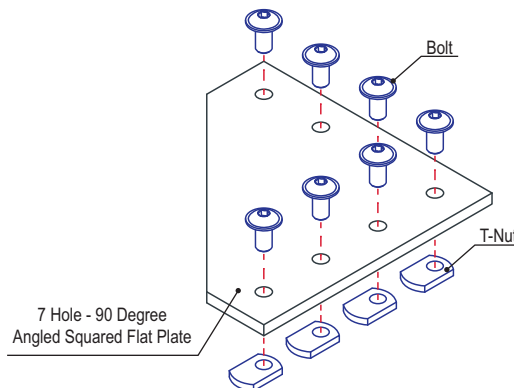

7 Hole - 90 Degree Angled Stacked Flat Plate

Part Description:

The 7 hole - 90 degree angled stacked flat plate is an external fastening method that requires no machining services. This flat plate creates a 90 degree angle between profiles and its shape reinforces the strength of the connection. It is a durable option that is easy to assemble and can be reconfigured and reused. **Tip:** Use double or triple slide-in economy T-nuts (pg. 364-365) to save time and money. Pre-load your hardware prior to connecting profiles to simplify your assembly.

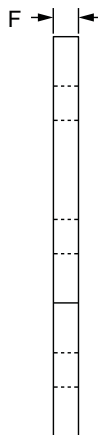
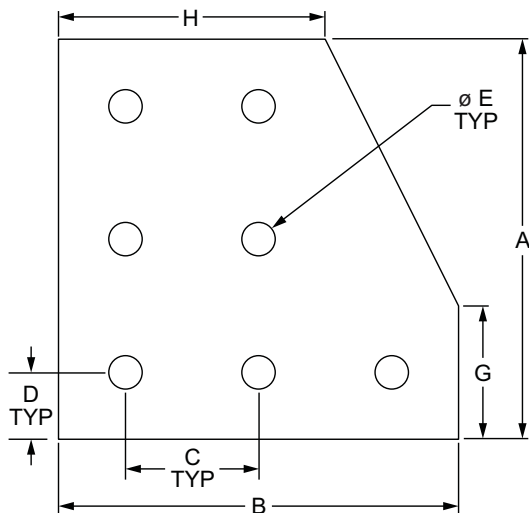

Part No.	Series	Material	Alloy*	Finish	A	B	C	D	E	F	G	H	Weight
4129	10	Aluminum	6105-T5	Clear Anodize	3.000"	3.000"	1.000"	.500"	.257"	.188"	1.000"	2.000"	.133 lb
4129-Black	10			Black Anodize	3.000"	3.000"	1.000"	.500"	.257"	.188"	1.000"	2.000"	.133 lb
4329	15			Clear Anodize	4.500"	4.500"	1.500"	.750"	.328"	.250"	1.500"	3.000"	.414 lb
4329-Black	15			Black Anodize	4.500"	4.500"	1.500"	.750"	.328"	.250"	1.500"	3.000"	.414 lb
25-4129	25			Clear Anodize	75.00mm	75.00mm	25.00mm	12.50mm	6.30mm	4.00mm	25.00mm	50.00mm	.0508 kg
25-4129-Black	25			Black Anodize	75.00mm	75.00mm	25.00mm	12.50mm	6.30mm	4.00mm	25.00mm	50.00mm	.0508 kg
40-4329	40			Clear Anodize	120.00mm	120.00mm	40.00mm	20.00mm	8.30mm	6.00mm	40.00mm	80.00mm	.1960 kg
40-4329-Black	40			Black Anodize	120.00mm	120.00mm	40.00mm	20.00mm	8.30mm	6.00mm	40.00mm	80.00mm	.1960 kg

* Or comparable

Suggested Hardware (Mount to T-Slot)

Part No.	Series	Qty.	Bolt	T-Nut
3321	10	7	1/4-20 x 1/2" FBHSCS	Economy
3320	15	7	5/16-18 x 11/16" FBHSCS	Economy
75-3404	25	7	M6 x 10mm BHSCS	Economy
75-3422	40	7	M8 x 16mm BHSCS	Economy

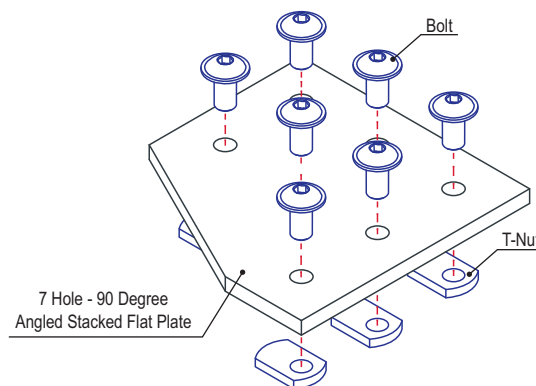



Part Description:

The 9 hole - 90 degree angled flat plate is an external fastening method that requires no machining services. This flat plate creates a 90 degree angle between profiles and its shape reinforces the strength of the connection. It is a durable option that is easy to assemble and can be reconfigured and reused. **Tip:** Use double or triple slide-in economy T-nuts (pg. 364-365) to save time and money. Pre-load your hardware prior to connecting profiles to simplify your assembly.

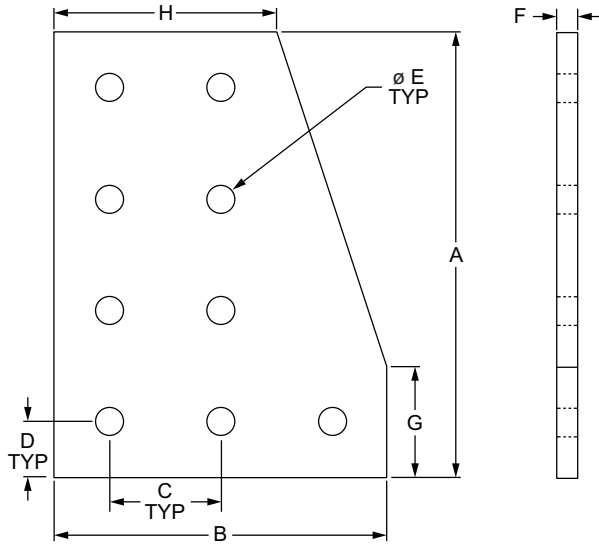

Part No.	Series	Material	Alloy*	Finish	A	B	C	D	E	F	G	H	Weight
4126	10	Aluminum	6105-T5	Clear Anodize	4.000"	3.000"	1.000"	.500"	.257"	.188"	1.000"	2.000"	.176 lb
4126-Black	10			Black Anodize	4.000"	3.000"	1.000"	.500"	.257"	.188"	1.000"	2.000"	.176 lb
4326	15			Clear Anodize	6.000"	4.500"	1.500"	.750"	.328"	.250"	1.500"	3.000"	.546 lb
4326-Black	15			Black Anodize	6.000"	4.500"	1.500"	.750"	.328"	.250"	1.500"	3.000"	.546 lb

* Or comparable

Suggested Hardware (Mount to T-Slot)

Part No.	Series	Qty.	Bolt	T-Nut
3321	10	9	1/4-20 x 1/2" FBHSCS	Economy
3320	15	9	5/16-18 x 11/16" FBHSCS	Economy

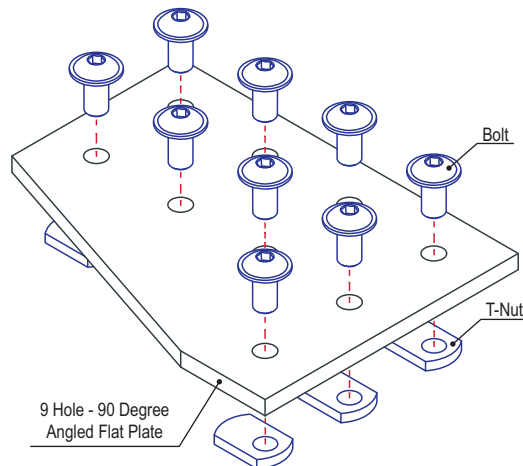

10 Hole - 90 Degree Angled Flat Plate

Part Description:

The 10 hole - 90 degree angled flat plate is an external fastening method that requires no machining services. This flat plate creates a 90 degree angle between profiles and its shape reinforces the strength of the connection. It is a durable option that is easy to assemble and can be reconfigured and reused. **Tip:** Use double or triple slide-in economy T-nuts (pg. 364-365) to save time and money. Pre-load your hardware prior to connecting profiles to simplify your assembly.

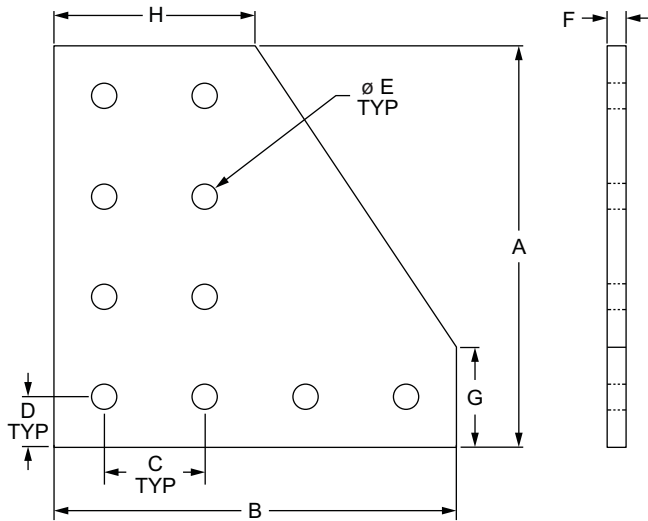

Part No.	Series	Material	Alloy*	Finish	A	B	C	D	E	F	G	H	Weight
4127	10	Aluminum	6105-T5	Clear Anodize	4.000"	4.000"	1.000"	.500"	.257"	.188"	1.000"	2.000"	.222 lb
4127-Black	10			Black Anodize	4.000"	4.000"	1.000"	.500"	.257"	.188"	1.000"	2.000"	.222 lb
4327	15			Clear Anodize	6.000"	6.000"	1.500"	.750"	.328"	.250"	1.500"	3.000"	.688 lb
4327-Black	15			Black Anodize	6.000"	6.000"	1.500"	.750"	.328"	.250"	1.500"	3.000"	.688 lb

* Or comparable

Suggested Hardware (Mount to T-Slot)

Part No.	Series	Qty.	Bolt	T-Nut
3321	10	10	1/4-20 x 1/2" FBHSCS	Economy
3320	15	10	5/16-18 x 11/16" FBHSCS	Economy

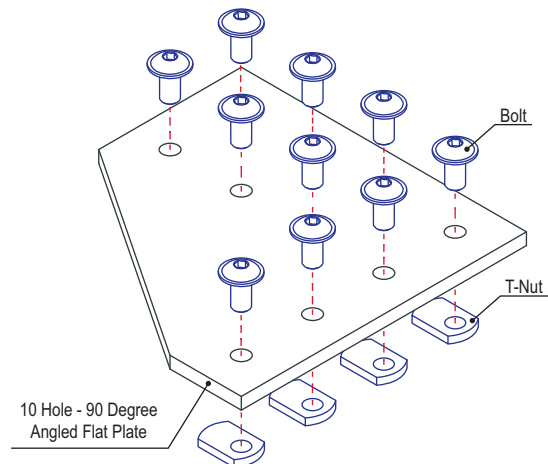



Part Description:

The 12 hole - 90 degree angled flat plate is an external fastening method that requires no machining services. This flat plate creates a 90 degree angle between profiles and its shape reinforces the strength of the connection. It is a durable option that is easy to assemble and can be reconfigured and reused. **Tip:** Use double or triple slide-in economy T-nuts (pg. 364-365) to save time and money. Pre-load your hardware prior to connecting profiles to simplify your assembly.

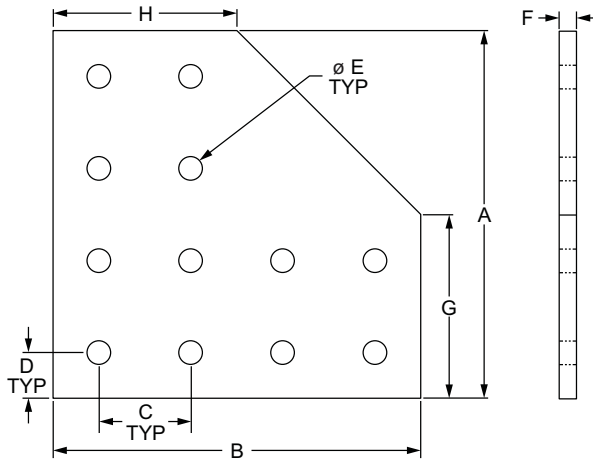

Part No.	Series	Material	Alloy*	Finish	A	B	C	D	E	F	G	H	Weight
4128	10	Aluminum	6105-T5	Clear Anodize	4.000"	4.000"	1.000"	.500"	.257"	.188"	2.000"	2.000"	.244 lb
4128-Black	10			Black Anodize	4.000"	4.000"	1.000"	.500"	.257"	.188"	2.000"	2.000"	.244 lb
4328	15			Clear Anodize	6.000"	6.000"	1.500"	.750"	.328"	.250"	3.000"	3.000"	.752 lb
4328-Black	15			Black Anodize	6.000"	6.000"	1.500"	.750"	.328"	.250"	3.000"	3.000"	.752 lb
25-4128	25			Clear Anodize	100.00mm	100.00mm	25.00mm	12.50mm	6.30mm	4.00mm	50.00mm	50.00mm	.1769 kg
25-4128-Black	25			Black Anodize	100.00mm	100.00mm	25.00mm	12.50mm	6.30mm	4.00mm	50.00mm	50.00mm	.1769 kg
40-4328	40			Clear Anodize	160.00mm	160.00mm	40.00mm	20.00mm	8.30mm	6.00mm	80.00mm	80.00mm	.3483 kg
40-4328-Black	40			Black Anodize	160.00mm	160.00mm	40.00mm	20.00mm	8.30mm	6.00mm	80.00mm	80.00mm	.3483 kg

* Or comparable

Suggested Hardware (Mount to T-Slot)

Part No.	Series	Qty.	Bolt	T-Nut
3321	10	12	1/4-20 x 1/2" FBHSCS	Economy
3320	15	12	5/16-18 x 11/16" FBHSCS	Economy
75-3404	25	12	M6 x 10mm BHSCS	Economy
75-3422	40	12	M8 x 16mm BHSCS	Economy

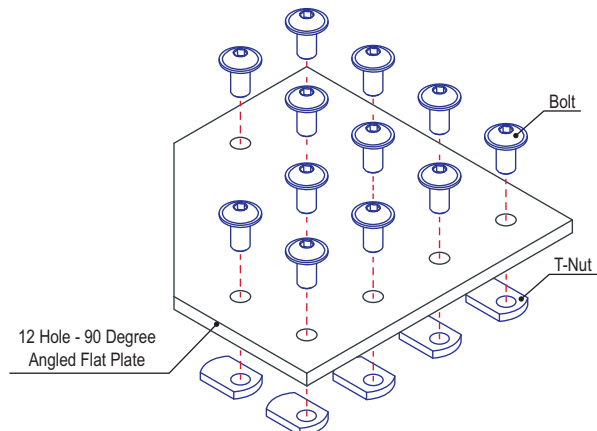

4 Hole - 15 Degree Angled Flat Plate

Part Description:

The 4 hole - 15 degree angled flat plate is an external fastening method that requires no machining services. This flat plate creates a 15 degree angle between profiles and its shape reinforces the strength of the connection. It is a durable option that is easy to assemble and can be reconfigured and reused. **Tip:** Use a double slide-in economy T-nut (pg. 364) to save time and money. Pre-load your hardware prior to connecting profiles to simplify your assembly.

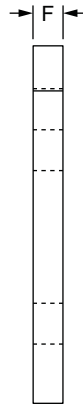
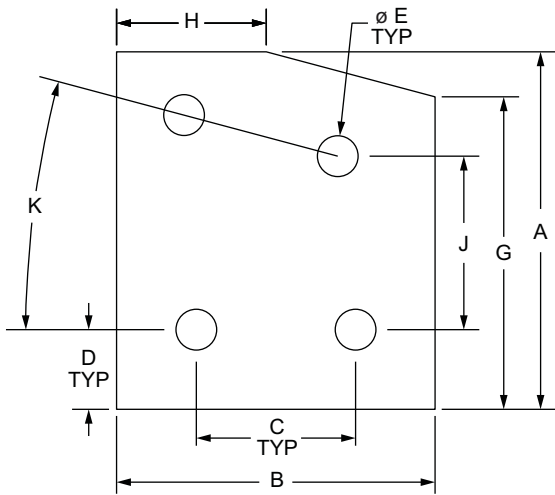

Part No.	Series	Material	Alloy*	Finish	A	B	C	D	E	F	G	H	J	K	Weight	
4110	10	Aluminum	6105-T5	Clear Anodize	2.250"	2.000"	1.000"	.500"	.257"	.188"	1.966"	.940"	1.092"	15°	.075 lb	
4110-Black	10			Black Anodize	2.250"	2.000"	1.000"	.500"	.257"	.188"	.188"	1.966"	.940"	1.092"	15°	.075 lb
4316	15			Clear Anodize	3.500"	3.000"	1.500"	.750"	.328"	.250"	.250"	2.949"	.944"	1.617"	15°	.104 lb
4316-Black	15			Black Anodize	3.500"	3.000"	1.500"	.750"	.328"	.250"	.250"	2.949"	.944"	1.617"	15°	.104 lb
40-4316	40			Clear Anodize	94.00mm	80.00mm	40.00mm	20.00mm	8.30mm	6.00mm	6.00mm	79.20mm	24.80mm	43.40mm	15°	.1057 kg
40-4316-Black	40			Black Anodize	94.00mm	80.00mm	40.00mm	20.00mm	8.30mm	6.00mm	6.00mm	79.20mm	24.80mm	43.40mm	15°	.1057 kg

* Or comparable

Suggested Hardware (Mount to T-Slot)

Part No.	Series	Qty.	Bolt	T-Nut
3321	10	4	1/4-20 x 1/2" FBHSCS	Economy
3320	15	4	5/16-18 x 11/16" FBHSCS	Economy
75-3422	40	4	M8 x 16mm BHSCS	Economy

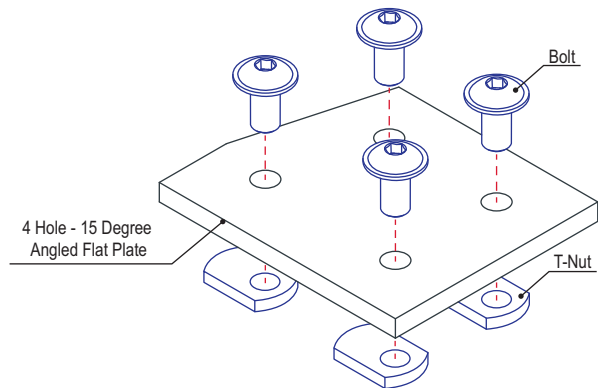



Part Description:

The 6 hole - 15 degree angled flat plate is an external fastening method that requires no machining services. This flat plate creates a 15 degree angle between profiles and its shape reinforces the strength of the connection. It is a durable option that is easy to assemble and can be reconfigured and reused. **Tip:** Use a double slide-in economy T-nut (pg. 364) to save time and money. Pre-load your hardware prior to connecting profiles to simplify your assembly.

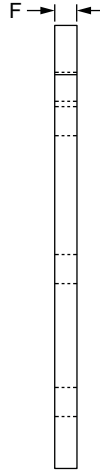
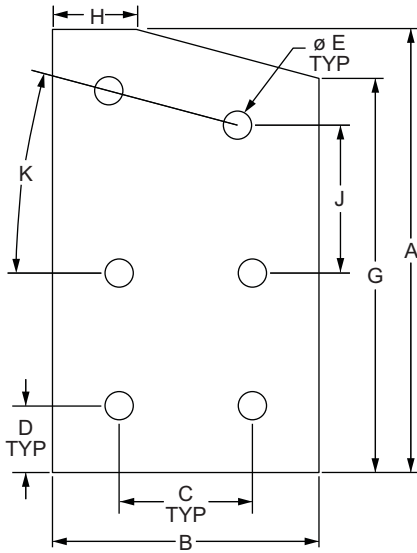

Part No.	Series	Material	Alloy*	Finish	A	B	C	D	E	F	G	H	J	K	Weight
4315	15	Aluminum	6105-T5	Clear Anodize	5.000"	3.000"	1.500"	.750"	.328"	.250"	4.307"	2.056"	1.669"	15°	.336 lb
4315-Black	15			Black Anodize	5.000"	3.000"	1.500"	.750"	.328"	.250"	4.307"	2.056"	1.669"	15°	.336 lb

* Or comparable

Suggested Hardware (Mount to T-Slot)

Part No.	Series	Qty.	Bolt	T-Nut
3320	15	6	5/16-18 x 11/16" FBHSCS	Economy

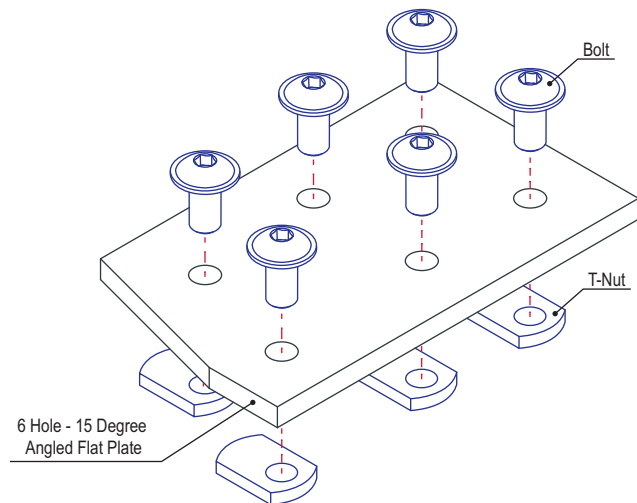

4 Hole - 30 Degree Angled Flat Plate

Part Description:

The 4 hole - 30 degree angled flat plate is an external fastening method that requires no machining services. This flat plate creates a 30 degree angle between profiles and its shape reinforces the strength of the connection. It is a durable option that is easy to assemble and can be reconfigured and reused. **Tip:** Use a double slide-in economy T-nut (pg. 364) to save time and money. Pre-load your hardware prior to connecting profiles to simplify your assembly.

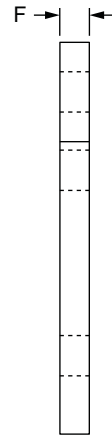
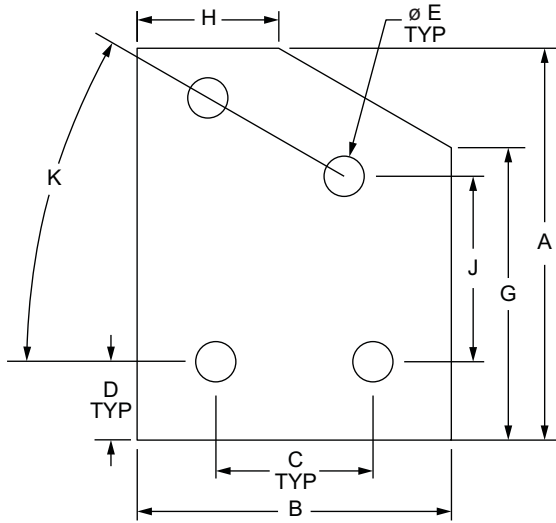

Part No.	Series	Material	Alloy*	Finish	A	B	C	D	E	F	G	H	J	K	Weight
4143	10	Aluminum	6105-T5	Clear Anodize	2.500"	2.000"	1.000"	.500"	.257"	.188"	1.866"	.902"	1.183"	30°	.080 lb
4143-Black	10			Black Anodize	2.500"	2.000"	1.000"	.500"	.257"	.188"	1.866"	.902"	1.183"	30°	.080 lb
4331	15			Clear Anodize	3.500"	3.000"	1.500"	.750"	.328"	.250"	2.799"	1.786"	1.650"	30°	.234 lb
4331-Black	15			Black Anodize	3.500"	3.000"	1.500"	.750"	.328"	.250"	2.799"	1.786"	1.650"	30°	.234 lb
40-4331	40			Clear Anodize	93.40mm	80.00mm	40.00mm	20.00mm	8.30mm	6.00mm	75.20mm	48.50mm	45.50mm	30°	.1084 kg
40-4331-Black	40			Black Anodize	93.40mm	80.00mm	40.00mm	20.00mm	8.30mm	6.00mm	75.20mm	48.50mm	45.50mm	30°	.1084 kg

* Or comparable

Suggested Hardware (Mount to T-Slot)

Part No.	Series	Qty.	Bolt	T-Nut
3321	10	4	1/4-20 x 1/2" FBHSCS	Economy
3320	15	4	5/16-18 x 11/16" FBHSCS	Economy
75-3422	40	4	M8 x 16mm BHSCS	Economy

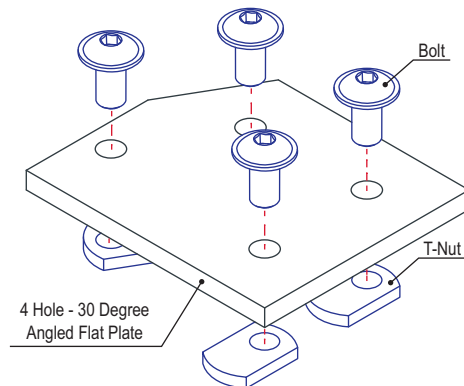



Part Description:

The 6 hole - 30 degree angled flat plate is an external fastening method that requires no machining services. This flat plate creates a 30 degree angle between profiles and its shape reinforces the strength of the connection. It is a durable option that is easy to assemble and can be reconfigured and reused. **Tip:** Use a double slide-in economy T-nut (pg. 364) to save time and money. Pre-load your hardware prior to connecting profiles to simplify your assembly.

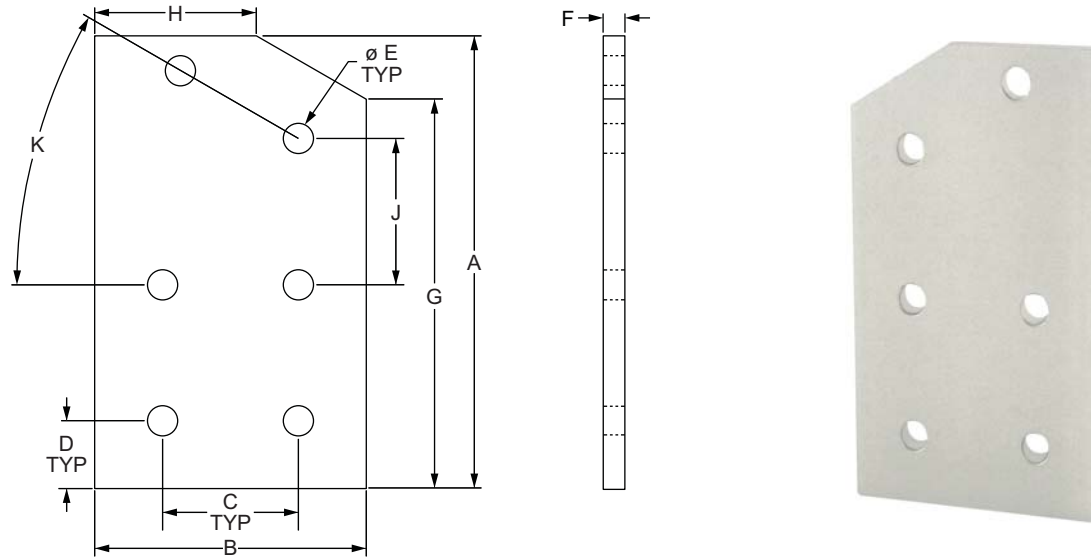

Part No.	Series	Material	Alloy*	Finish	A	B	C	D	E	F	G	H	J	K	Weight
4330	15	Aluminum	6105-T5	Clear Anodize	5.000"	3.000"	1.500"	.750"	.328"	.250"	4.299"	1.786"	1.616"	30°	.338 lb
4330-Black	15			Black Anodize	5.000"	3.000"	1.500"	.750"	.328"	.250"	4.299"	1.786"	1.616"	30°	.338 lb
40-4330	40			Clear Anodize	133.40mm	80.00mm	40.00mm	20.00mm	8.30mm	6.00mm	115.20mm	48.50mm	45.50mm	30°	.1551 kg
40-4330-Black	40			Black Anodize	133.40mm	80.00mm	40.00mm	20.00mm	8.30mm	6.00mm	115.20mm	48.50mm	45.50mm	30°	.1551 kg

* Or comparable

Suggested Hardware (Mount to T-Slot)

Part No.	Series	Qty.	Bolt	T-Nut
3320	15	6	5/16-18 x 11/16" FBHSCS	Economy
75-3422	40	6	M8 x 16mm BHSCS	Economy

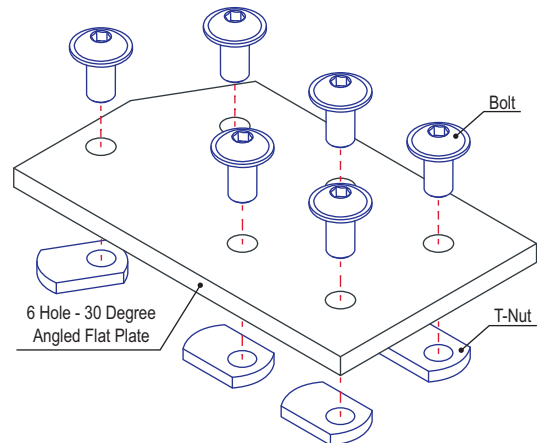

4 Hole - 45 Degree Angled Flat Plate

Part Description:

The 4 hole - 45 degree angled flat plate is an external fastening method that requires no machining services. This flat plate creates a 45 degree angle between profiles and its shape reinforces the strength of the connection. It is a durable option that is easy to assemble and can be reconfigured and reused. **Tip:** Use a double slide-in economy T-nut (pg. 364) to save time and money. Pre-load your hardware prior to connecting profiles to simplify your assembly.

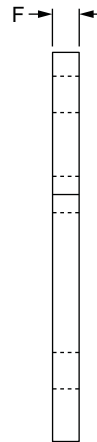
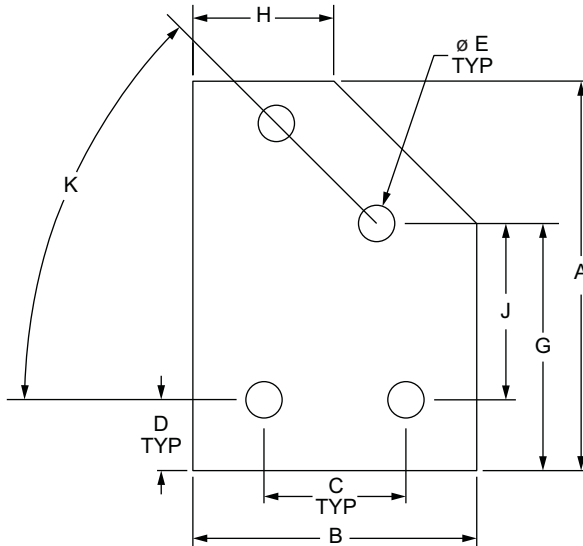

Part No.	Series	Material	Alloy*	Finish	A	B	C	D	E	F	G	H	J	K	Weight	
4145	10	Aluminum	6105-T5	Clear Anodize	2.750"	2.000"	1.000"	.500"	.257"	.188"	1.744"	.994"	1.244"	45°	.086 lb	
4145-Black	10			Black Anodize	2.750"	2.000"	1.000"	.500"	.257"	.188"	.188"	1.744"	.994"	1.244"	45°	.086 lb
4346	15			Clear Anodize	4.500"	3.000"	1.500"	.750"	.328"	.250"	2.561"	1.061"	1.811"	45°	.270 lb	
4346-Black	15			Black Anodize	4.500"	3.000"	1.500"	.750"	.328"	.250"	2.561"	1.061"	1.811"	45°	.270 lb	
40-4346	40			Clear Anodize	120.00mm	80.00mm	40.00mm	20.00mm	8.30mm	6.00mm	68.60mm	28.60mm	48.60mm	45°	.1111 kg	
40-4346-Black	40			Black Anodize	120.00mm	80.00mm	40.00mm	20.00mm	8.30mm	6.00mm	68.60mm	28.60mm	48.60mm	45°	.1111 kg	

* Or comparable

Suggested Hardware (Mount to T-Slot)

Part No.	Series	Qty.	Bolt	T-Nut
3321	10	4	1/4-20 x 1/2" FBHSCS	Economy
3320	15	4	5/16-18 x 11/16" FBHSCS	Economy
75-3422	40	4	M8 x 16mm BHSCS	Economy

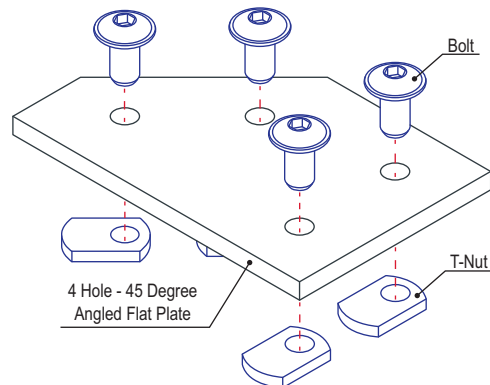



Part Description:

The 6 hole - 45 degree angled flat plate is an external fastening method that requires no machining services. This flat plate creates a 45 degree angle between profiles and its shape reinforces the strength of the connection. It is a durable option that is easy to assemble and can be reconfigured and reused. **Tip:** Use a double slide-in economy T-nut (pg. 364) to save time and money. Pre-load your hardware prior to connecting profiles to simplify your assembly.

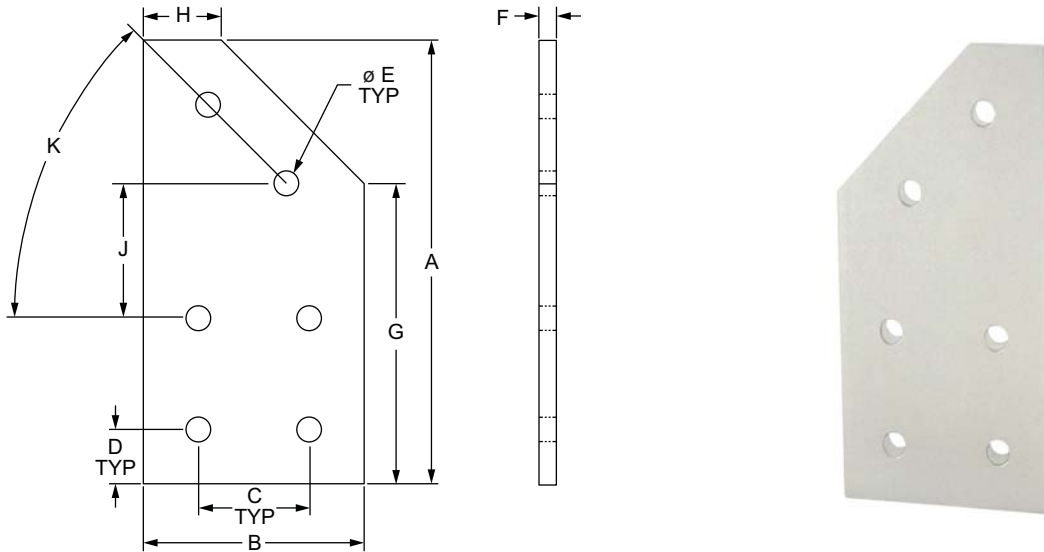

Part No.	Series	Material	Alloy*	Finish	A	B	C	D	E	F	G	H	J	K	Weight
4345	15	Aluminum	6105-T5	Clear Anodize	6.000"	3.000"	1.500"	.750"	.328"	.250"	4.061"	1.061"	1.811"	45°	.368 lb
4345-Black	15			Black Anodize	6.000"	3.000"	1.500"	.750"	.328"	.250"	4.061"	1.061"	1.811"	45°	.368 lb
40-4345	40			Clear Anodize	160.00mm	80.00mm	40.00mm	20.00mm	8.30mm	6.00mm	108.60mm	28.60mm	48.60mm	45°	.1801 kg
40-4345-Black	40			Black Anodize	160.00mm	80.00mm	40.00mm	20.00mm	8.30mm	6.00mm	108.60mm	28.60mm	48.60mm	45°	.1801 kg

* Or comparable

Suggested Hardware (Mount to T-Slot)

Part No.	Series	Qty.	Bolt	T-Nut
3320	15	6	5/16-18 x 11/16" FBHSCS	Economy
75-3422	40	6	M8 x 16mm BHSCS	Economy

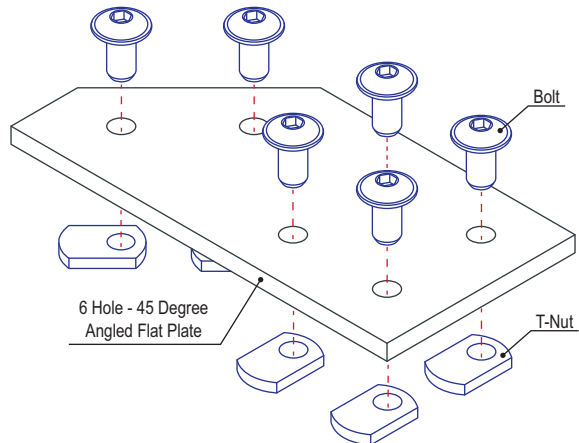

4 Hole - 60 Degree Angled Flat Plate



Part Description:

The 4 hole - 60 degree angled flat plate is an external fastening method that requires no machining services. This flat plate creates a 60 degree angle between profiles and its shape reinforces the strength of the connection. It is a durable option that is easy to assemble and can be reconfigured and reused. **Tip:** Use a double slide-in economy T-nut (pg. 364) to save time and money. Pre-load your hardware prior to connecting profiles to simplify your assembly.

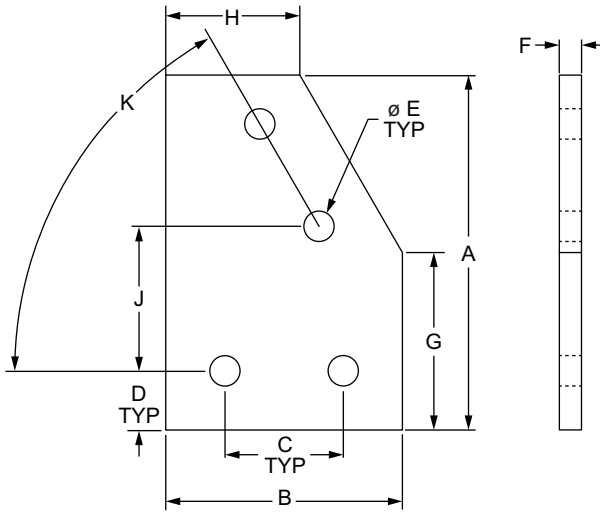

Part No.	Series	Material	Alloy*	Finish	A	B	C	D	E	F	G	H	J	K	Weight
4164	10	Aluminum	6105-T5	Clear Anodize	3.000"	2.000"	1.000"	.500"	.257"	.188"	1.500"	1.134"	1.221"	60°	.092 lb
4164-Black	10			Black Anodize	3.000"	2.000"	1.000"	.500"	.257"	.188"	1.500"	1.134"	1.221"	60°	.092 lb
4361	15			Clear Anodize	4.500"	3.000"	1.500"	.750"	.328"	.250"	2.250"	1.701"	1.558"	60°	.280 lb
4361-Black	15			Black Anodize	4.500"	3.000"	1.500"	.750"	.328"	.250"	2.250"	1.701"	1.558"	60°	.280 lb
40-4361	40			Clear Anodize	120.00mm	80.00mm	40.00mm	20.00mm	8.30mm	6.00mm	60.00mm	45.40mm	47.30mm	60°	.1296 kg
40-4361-Black	40			Black Anodize	120.00mm	80.00mm	40.00mm	20.00mm	8.30mm	6.00mm	60.00mm	45.40mm	47.30mm	60°	.1296 kg

* Or comparable

Suggested Hardware (Mount to T-Slot)

Part No.	Series	Qty.	Bolt	T-Nut
3321	10	4	1/4-20 x 1/2" FBHSCS	Economy
3320	15	4	5/16-18 x 11/16" FBHSCS	Economy
75-3422	40	4	M8 x 16mm BHSCS	Economy

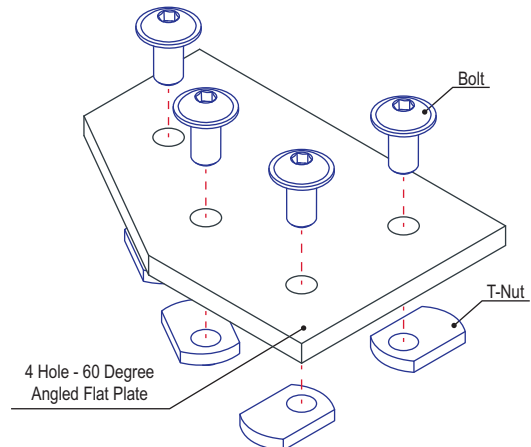



Part Description:

The 6 hole - 60 degree angled flat plate is an external fastening method that requires no machining services. This flat plate creates a 60 degree angle between profiles and its shape reinforces the strength of the connection. It is a durable option that is easy to assemble and can be reconfigured and reused. **Tip:** Use a double slide-in economy T-nut (pg. 364) to save time and money. Pre-load your hardware prior to connecting profiles to simplify your assembly.

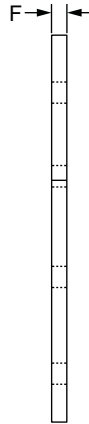
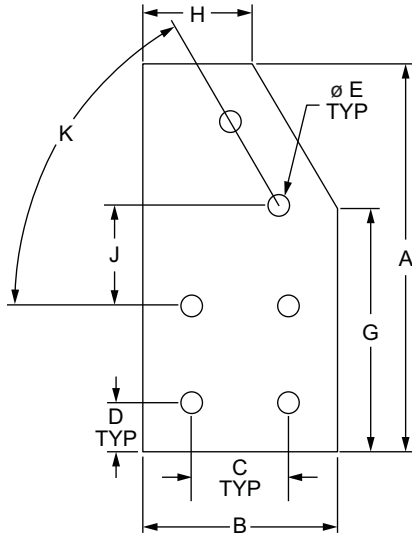

Part No.	Series	Material	Alloy*	Finish	A	B	C	D	E	F	G	H	J	K	Weight
4362	15	Aluminum	6105-T5	Clear Anodize	6.000"	3.000"	1.500"	.750"	.328"	.250"	3.750"	1.701"	1.558"	60°	.384 lb
4362-Black	15			Black Anodize	6.000"	3.000"	1.500"	.750"	.328"	.250"	3.750"	1.701"	1.558"	60°	.384 lb
40-4362	40			Clear Anodize	160.00mm	80.00mm	40.00mm	20.00mm	8.30mm	6.00mm	100.00mm	45.40mm	47.30mm	60°	.1837 kg
40-4362-Black	40			Black Anodize	160.00mm	80.00mm	40.00mm	20.00mm	8.30mm	6.00mm	100.00mm	45.40mm	47.30mm	60°	.1837 kg

* Or comparable

Suggested Hardware (Mount to T-Slot)

Part No.	Series	Qty.	Bolt	T-Nut
3320	15	6	5/16-18 x 11/16" FBHSCS	Economy
75-3422	40	6	M8 x 16mm BHSCS	Economy

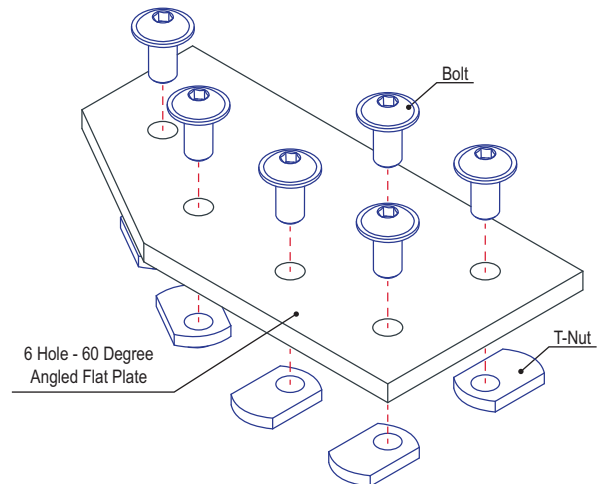

4 Hole - Tee Flat Plate

Part Description:

The 4 hole - tee flat plate is a strong, external fastening method that requires no machining services and can be used to connect more than two profiles together. This fastening option can provide infinite positioning along the profile T-slot, allowing for a large degree of adjustability. It is a long-lasting connection that is easily assembled and can be repositioned and reused. **Tip:** Use a double slide-in economy T-nut (pg. 364) to save time and money. Pre-load your hardware prior to connecting profiles to simplify your assembly.

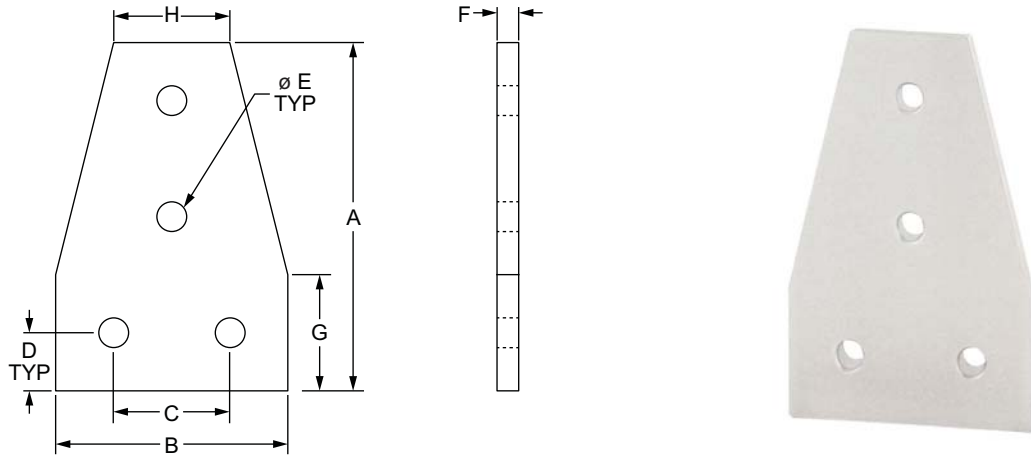

Part No.	Series	Material	Alloy*	Finish	A	B	C	D	E	F	G	H	Weight
4141	10	Aluminum	6105-T5	Clear Anodize	3.000"	2.000"	1.000"	.500"	.257"	.188"	1.000"	1.000"	.086 lb
4141-Black	10			Black Anodize	3.000"	2.000"	1.000"	.500"	.257"	.188"	1.000"	1.000"	.086 lb
4341	15			Clear Anodize	4.500"	3.000"	1.500"	.750"	.328"	.250"	1.500"	1.500"	.267 lb
4341-Black	15			Black Anodize	4.500"	3.000"	1.500"	.750"	.328"	.250"	1.500"	1.500"	.267 lb
25-4141	25			Clear Anodize	75.00mm	50.00mm	25.00mm	12.50mm	6.30mm	4.00mm	25.00mm	25.00mm	.0318 kg
25-4141-Black	25			Black Anodize	75.00mm	50.00mm	25.00mm	12.50mm	6.30mm	4.00mm	25.00mm	25.00mm	.0318 kg
40-4341	40			Clear Anodize	120.00mm	80.00mm	40.00mm	20.00mm	8.30mm	6.00mm	40.00mm	40.00mm	.1207 kg
40-4341-Black	40			Black Anodize	120.00mm	80.00mm	40.00mm	20.00mm	8.30mm	6.00mm	40.00mm	40.00mm	.1207 kg

* Or comparable

Suggested Hardware (Mount to T-Slot)

Part No.	Series	Qty.	Bolt	T-Nut
3321	10	4	1/4-20 x 1/2" FBHSCS	Economy
3320	15	4	5/16-18 x 11/16" FBHSCS	Economy
75-3404	25	4	M6 x 10mm BHSCS	Economy
75-3422	40	4	M8 x 16mm BHSCS	Economy

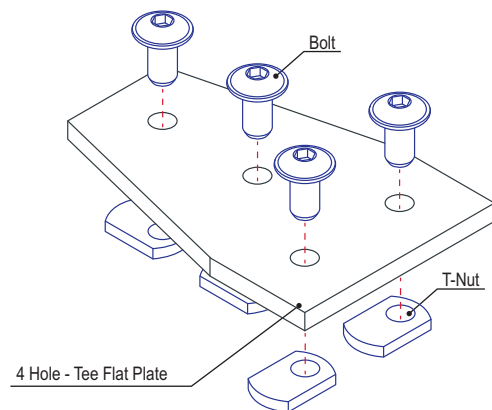

Part Description:

The 5 hole - tee flat plate is a strong, external fastening method that requires no machining services and can be used to connect more than two profiles together. This fastening option can provide infinite positioning along the profile T-slot, allowing for a large degree of adjustability. It is a long-lasting connection that is easily assembled and can be repositioned and reused. **Tip:** Use double or triple slide-in economy T-nuts (pg. 364-365) to save time and money. Pre-load your hardware prior to connecting profiles to simplify your assembly.

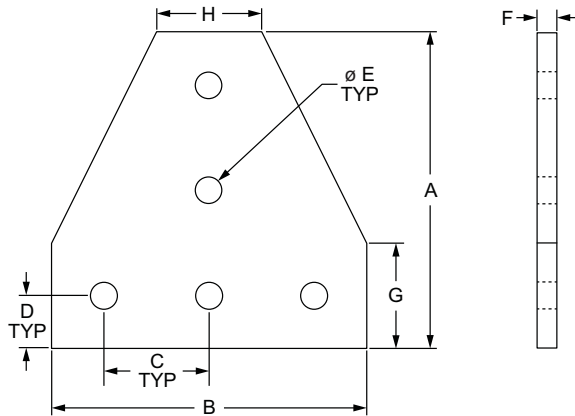

Part No.	Series	Material	Alloy*	Finish	A	B	C	D	E	F	G	H	Weight	
4140	10	Aluminum	6105-T5	Clear Anodize	3.000"	3.000"	1.000"	.500"	.257"	.188"	1.000"	1.000"	.118 lb	
4140-Black	10			Black Anodize	3.000"	3.000"	1.000"	.500"	.500"	.257"	.188"	1.000"	1.000"	.118 lb
4340	15			Clear Anodize	4.500"	4.500"	1.500"	.750"	.328"	.250"	1.500"	1.500"	1.500"	.364 lb
4340-Black	15			Black Anodize	4.500"	4.500"	1.500"	.750"	.328"	.250"	1.500"	1.500"	1.500"	.364 lb
25-4140	25			Clear Anodize	75.00mm	75.00mm	25.00mm	12.50mm	6.30mm	4.00mm	25.00mm	25.00mm	25.00mm	.0210 kg
25-4140-Black	25			Black Anodize	75.00mm	75.00mm	25.00mm	12.50mm	6.30mm	4.00mm	25.00mm	25.00mm	25.00mm	.0210 kg
30-4340	30			Clear Anodize	90.00mm	90.00mm	30.00mm	15.00mm	6.30mm	4.00mm	30.00mm	30.00mm	30.00mm	.0645 kg
30-4340-Black	30			Black Anodize	90.00mm	90.00mm	30.00mm	15.00mm	6.30mm	4.00mm	30.00mm	30.00mm	30.00mm	.0645 kg
40-4340	40			Clear Anodize	120.00mm	120.00mm	40.00mm	20.00mm	8.30mm	6.00mm	40.00mm	40.00mm	40.00mm	.1734 kg
40-4340-Black	40			Black Anodize	120.00mm	120.00mm	40.00mm	20.00mm	8.30mm	6.00mm	40.00mm	40.00mm	40.00mm	.1734 kg
45-4340	45			Clear Anodize	135.00mm	135.00mm	45.00mm	22.50mm	8.30mm	6.00mm	45.00mm	45.00mm	45.00mm	.2203 kg
45-4340-Black	45			Black Anodize	135.00mm	135.00mm	45.00mm	22.50mm	8.30mm	6.00mm	45.00mm	45.00mm	45.00mm	.2203 kg

* Or comparable

Suggested Hardware (Mount to T-Slot)

Part No.	Series	Qty.	Bolt	T-Nut
3321	10	5	1/4-20 x 1/2" FBHSCS	Economy
3320	15	5	5/16-18 x 11/16" FBHSCS	Economy
75-3404	25	5	M6 x 10mm BHSCS	Economy
75-3600	30	5	M6 x 12mm BHSCS	Drop-in
75-3422	40	5	M8 x 16mm BHSCS	Economy
75-3619	45	5	M8 x 18mm BHSCS	Drop-in

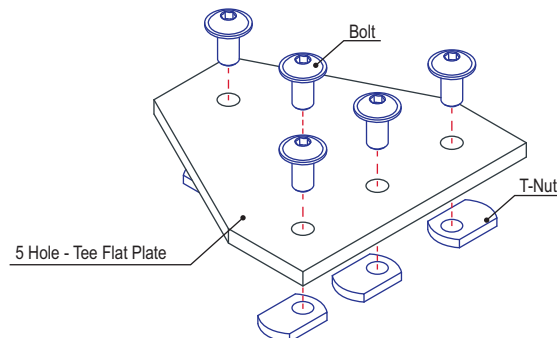

6 Hole - Tee Flat Plate

Part Description:

The 6 hole - tee flat plate is a strong, external fastening method that requires no machining services and can be used to connect more than two profiles together. This fastening option can provide infinite positioning along the profile T-slot, allowing for a large degree of adjustability. It is a long-lasting connection that is easily assembled and can be repositioned and reused. **Tip:** Use double or triple slide-in economy T-nuts (pg. 364-365) to save time and money. Pre-load your hardware prior to connecting profiles to simplify your assembly.

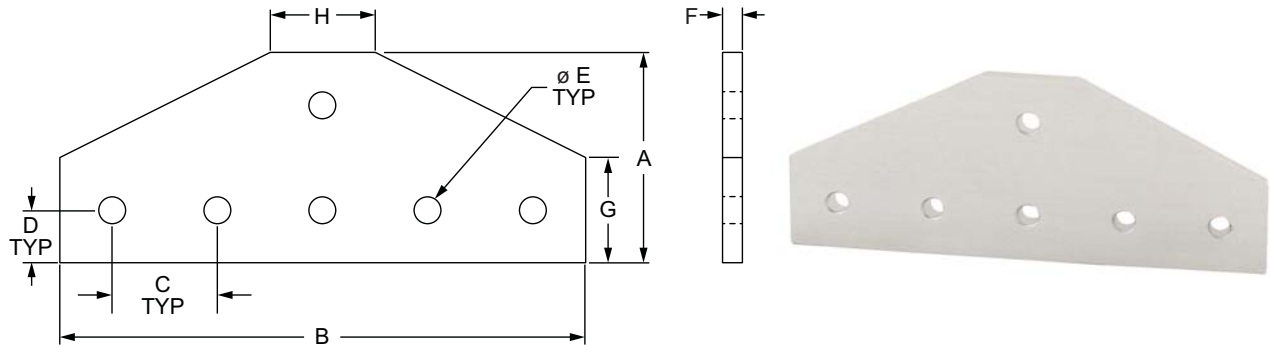

Part No.	Series	Material	Alloy*	Finish	A	B	C	D	E	F	G	H	Weight
4123	10	Aluminum	6105-T5	Clear Anodize	2.000"	5.000"	1.000"	.500"	.257"	.188"	1.000"	1.000"	.137 lb
4123-Black	10			Black Anodize	2.000"	5.000"	1.000"	.500"	.257"	.188"	1.000"	1.000"	.137 lb
4310	15			Clear Anodize	3.000"	7.500"	1.500"	.750"	.328"	.250"	1.500"	1.500"	.416 lb
4310-Black	15			Black Anodize	3.000"	7.500"	1.500"	.750"	.328"	.250"	1.500"	1.500"	.416 lb

* Or comparable

Suggested Hardware (Mount to T-Slot)

Part No.	Series	Qty.	Bolt	T-Nut
3321	10	6	1/4-20 x 1/2" FBHSCS	Economy
3320	15	6	5/16-18 x 11/16" FBHSCS	Economy

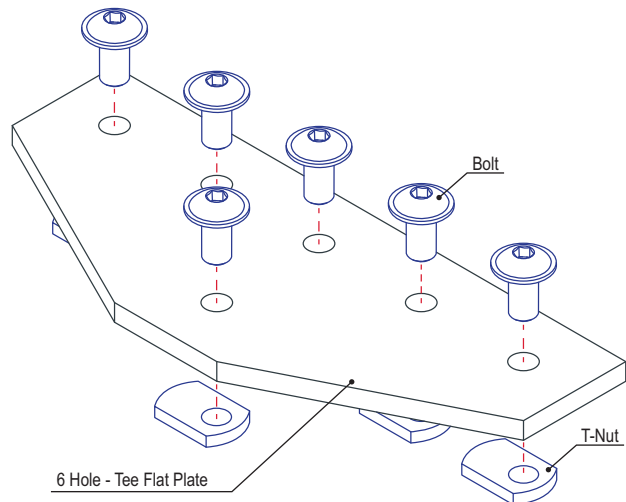

FASTENERS



Part Description:

The 7 hole - tee flat plate is a strong, external fastening method that requires no machining services and can be used to connect more than two profiles together. This fastening option can provide infinite positioning along the profile T-slot, allowing for a large degree of adjustability. It is a long-lasting connection that is easily assembled and can be repositioned and reused. **Tip:** Use double or triple slide-in economy T-nuts (pg. 364-365) to save time and money. Pre-load your hardware prior to connecting profiles to simplify your assembly.

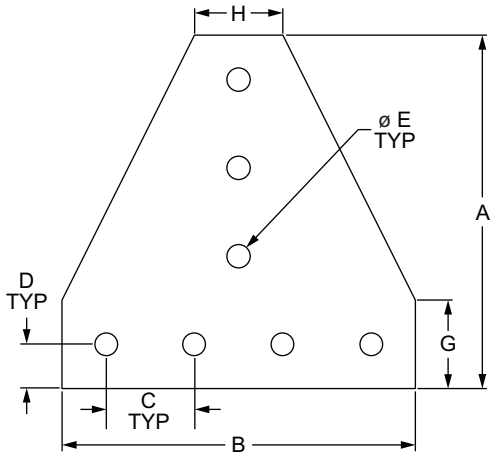

Part No.	Series	Material	Alloy*	Finish	A	B	C	D	E	F	G	H	Weight
4112	10	Aluminum	6105-T5	Clear Anodize	4.000"	4.000"	1.000"	.500"	.257"	.188"	1.000"	1.000"	.199 lb
4112-Black	10			Black Anodize	4.000"	4.000"	1.000"	.500"	.257"	.188"	1.000"	1.000"	.199 lb
4312	15			Clear Anodize	6.000"	6.000"	1.500"	.750"	.328"	.250"	1.500"	1.500"	.604 lb
4312-Black	15			Black Anodize	6.000"	6.000"	1.500"	.750"	.328"	.250"	1.500"	1.500"	.604 lb
25-4112	25			Clear Anodize	100.00mm	100.00mm	25.00mm	12.50mm	6.30mm	4.00mm	25.00mm	25.00mm	.0739 kg
25-4112-Black	25			Black Anodize	100.00mm	100.00mm	25.00mm	12.50mm	6.30mm	4.00mm	25.00mm	25.00mm	.0739 kg
40-4312	40			Clear Anodize	160.00mm	160.00mm	40.00mm	20.00mm	8.30mm	6.00mm	40.00mm	40.00mm	.2853 kg
40-4312-Black	40			Black Anodize	160.00mm	160.00mm	40.00mm	20.00mm	8.30mm	6.00mm	40.00mm	40.00mm	.2853 kg

* Or comparable

Suggested Hardware (Mount to T-Slot)

Part No.	Series	Qty.	Bolt	T-Nut
3321	10	7	1/4-20 x 1/2" FBHSCS	Economy
3320	15	7	5/16-18 x 11/16" FBHSCS	Economy
75-3404	25	7	M6 x 10mm BHSCS	Economy
75-3422	40	7	M8 x 16mm BHSCS	Economy

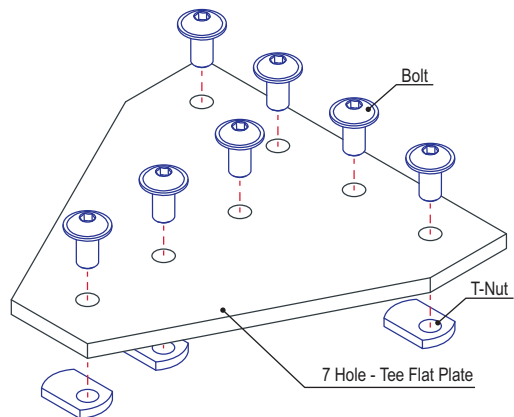

FASTENERS

8 Hole - Tee Flat Plate

Part Description:

The 8 hole - tee flat plate is a strong, external fastening method that requires no machining services and can be used to connect more than two profiles together. This fastening option can provide infinite positioning along the profile T-slot, allowing for a large degree of adjustability. It is a long-lasting connection that is easily assembled and can be repositioned and reused. **Tip:** Use double or triple slide-in economy T-nuts (pg. 364-365) to save time and money. Pre-load your hardware prior to connecting profiles to simplify your assembly.

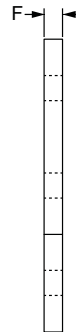
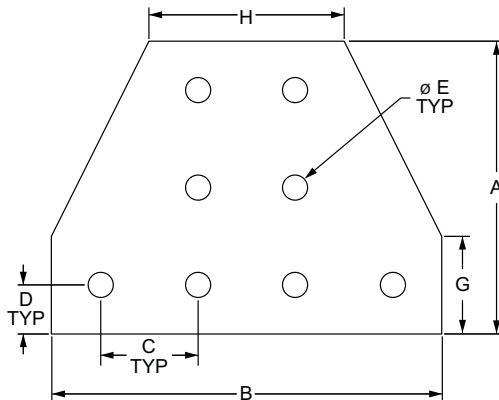

Part No.	Series	Material	Alloy*	Finish	A	B	C	D	E	F	G	H	Weight
4155	10	Aluminum	6105-T5	Clear Anodize	3.000"	4.000"	1.000"	.500"	.257"	.188"	1.000"	2.000"	.167 lb
4155-Black	10			Black Anodize	3.000"	4.000"	1.000"	.500"	.257"	.188"	1.000"	2.000"	.167 lb
4355	15			Clear Anodize	4.500"	6.000"	1.500"	.750"	.328"	.250"	1.500"	3.000"	.514 lb
4355-Black	15			Black Anodize	4.500"	6.000"	1.500"	.750"	.328"	.250"	1.500"	3.000"	.514 lb
25-4155	25			Clear Anodize	75.00mm	100.00mm	25.00mm	12.50mm	6.30mm	4.00mm	25.00mm	50.00mm	.0648 kg
25-4155-Black	25			Black Anodize	75.00mm	100.00mm	25.00mm	12.50mm	6.30mm	4.00mm	25.00mm	50.00mm	.0648 kg
40-4355	40			Clear Anodize	120.00mm	160.00mm	40.00mm	20.00mm	8.30mm	6.00mm	40.00mm	80.00mm	.2467 kg
40-4355-Black	40			Black Anodize	120.00mm	160.00mm	40.00mm	20.00mm	8.30mm	6.00mm	40.00mm	80.00mm	.2467 kg
45-4355	45			Clear Anodize	135.00mm	180.00mm	45.00mm	22.50mm	8.30mm	6.00mm	45.00mm	90.00mm	.3171 kg
45-4355-Black	45			Black Anodize	135.00mm	180.00mm	45.00mm	22.50mm	8.30mm	6.00mm	45.00mm	90.00mm	.3171 kg

* Or comparable

Suggested Hardware (Mount to T-Slot)

Part No.	Series	Qty.	Bolt	T-Nut
3321	10	8	1/4-20 x 1/2" FBHSCS	Economy
3320	15	8	5/16-18 x 11/16" FBHSCS	Economy
75-3404	25	8	M6 x 10mm BHSCS	Economy
75-3422	40	8	M8 x 16mm BHSCS	Economy
75-3619	45	8	M8 x 18mm BHSCS	Drop-in

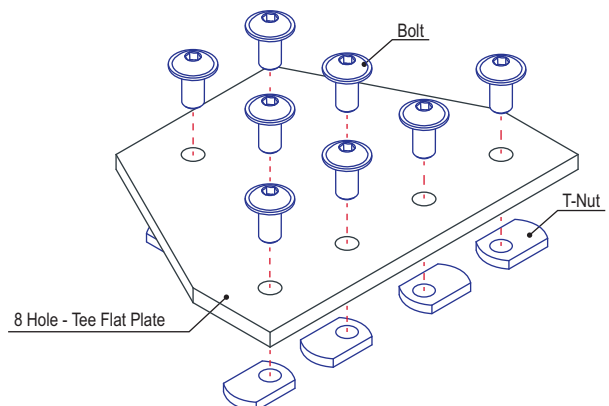



Part Description:

The 11 hole - tee flat plate is a strong, external fastening method that requires no machining services and can be used to connect more than two profiles together. This fastening option can provide infinite positioning along the profile T-slot, allowing for a large degree of adjustability. It is a long-lasting connection that is easily assembled and can be repositioned and reused. **Tip:** Use double or triple slide-in economy T-nuts (pg. 364-365) to save time and money. Pre-load your hardware prior to connecting profiles to simplify your assembly.

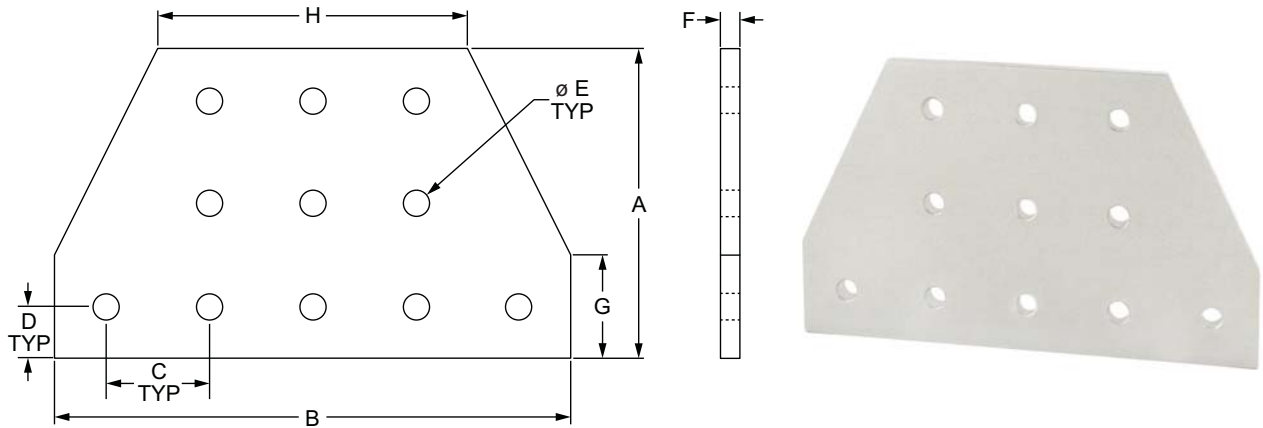

Part No.	Series	Material	Alloy*	Finish	A	B	C	D	E	F	G	H	Weight
4021	10	Aluminum	6105-T5	Clear Anodize	3.000"	5.000"	1.000"	.500"	.257"	.188"	1.000"	3.000"	.219 lb
4021-Black	10			Black Anodize	3.000"	5.000"	1.000"	.500"	.257"	.188"	1.000"	3.000"	.219 lb
4421	15			Clear Anodize	4.500"	7.000"	1.500"	.750"	.328"	.250"	1.500"	4.500"	.671 lb
4421-Black	15			Black Anodize	4.500"	7.000"	1.500"	.750"	.328"	.250"	1.500"	4.500"	.671 lb

* Or comparable

Suggested Hardware (Mount to T-Slot)

Part No.	Series	Qty.	Bolt	T-Nut
3321	10	11	1/4-20 x 1/2" FBHSCS	Economy
3320	15	11	5/16-18 x 11/16" FBHSCS	Economy

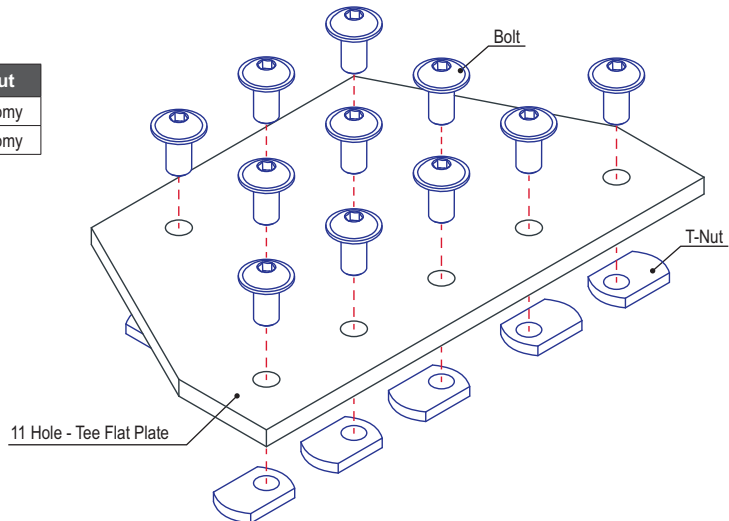

12 Hole - Tee Flat Plate

Part Description:

The 12 hole - tee flat plate is a strong, external fastening method that requires no machining services and can be used to connect more than two profiles together. This fastening option can provide infinite positioning along the profile T-slot, allowing for a large degree of adjustability. It is a long-lasting connection that is easily assembled and can be repositioned and reused. **Tip:** Use double or triple slide-in economy T-nuts (pg. 364-365) to save time and money. Pre-load your hardware prior to connecting profiles to simplify your assembly.

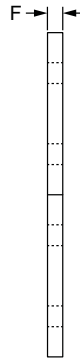
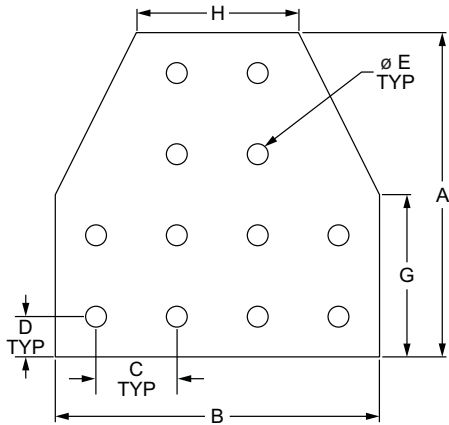

Part No.	Series	Material	Alloy*	Finish	A	B	C	D	E	F	G	H	Weight	
4125	10	Aluminum	6105-T5	Clear Anodize	4.000"	4.000"	1.000"	.500"	.257"	.188"	2.000"	2.000"	.239 lb	
4125-Black	10			Black Anodize	4.000"	4.000"	1.000"	.500"	.257"	.188"	.250"	3.000"	3.000"	.239 lb
4325	15			Clear Anodize	6.000"	6.000"	1.500"	.750"	.328"	.250"	3.000"	3.000"	.728 lb	
4325-Black	15			Black Anodize	6.000"	6.000"	1.500"	.750"	.328"	.250"	3.000"	3.000"	.728 lb	
25-4125	25			Clear Anodize	100.00mm	100.00mm	25.00mm	12.50mm	6.30mm	4.00mm	50.00mm	50.00mm	.0893 kg	
25-4125-Black	25			Black Anodize	100.00mm	100.00mm	25.00mm	12.50mm	6.30mm	4.00mm	50.00mm	50.00mm	.0893 kg	
40-4325	40			Clear Anodize	160.00mm	160.00mm	40.00mm	20.00mm	8.30mm	6.00mm	80.00mm	80.00mm	.3474 kg	
40-4325-Black	40			Black Anodize	160.00mm	160.00mm	40.00mm	20.00mm	8.30mm	6.00mm	80.00mm	80.00mm	.3474 kg	

* Or comparable

Suggested Hardware (Mount to T-Slot)

Part No.	Series	Qty.	Bolt	T-Nut
3321	10	12	1/4-20 x 1/2" FBHSCS	Economy
3320	15	12	5/16-18 x 11/16" FBHSCS	Economy
75-3404	25	12	M6 x 10mm BHSCS	Economy
75-3422	40	12	M8 x 16mm BHSCS	Economy

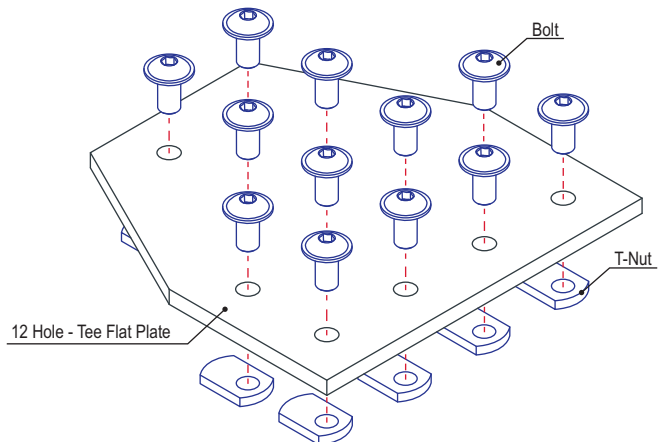



Part Description:

The 16 hole - tee flat plate is a strong, external fastening method that requires no machining services and can be used to connect more than two profiles together. This fastening option can provide infinite positioning along the profile T-slot, allowing for a large degree of adjustability. It is a long-lasting connection that is easily assembled and can be repositioned and reused. **Tip:** Use double or triple slide-in economy T-nuts (pg. 364-365) to save time and money. Pre-load your hardware prior to connecting profiles to simplify your assembly.

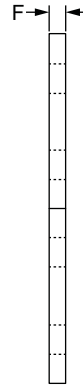
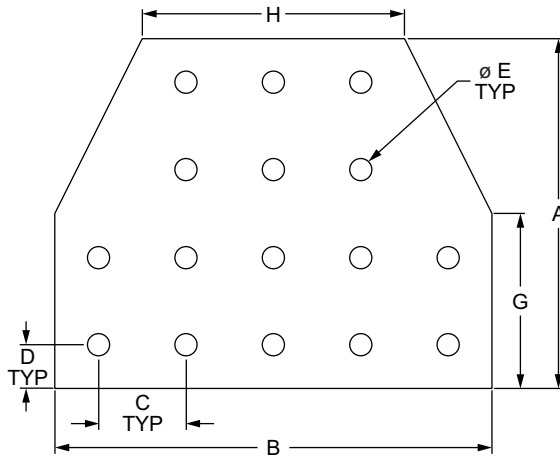

Part No.	Series	Material	Alloy*	Finish	A	B	C	D	E	F	G	H	Weight
4022	10	Aluminum	6105-T5	Clear Anodize	4.000"	5.000"	1.000"	.500"	.257"	.188"	2.000"	3.000"	.307 lb
4022-Black	10			Black Anodize	4.000"	5.000"	1.000"	.500"	.257"	.188"	2.000"	3.000"	.307 lb
4422	15			Clear Anodize	6.000"	7.500"	1.500"	.750"	.328"	.250"	3.000"	4.500"	.935 lb
4422-Black	15			Black Anodize	6.000"	7.500"	1.500"	.750"	.328"	.250"	3.000"	4.500"	.935 lb

* Or comparable

Suggested Hardware (Mount to T-Slot)

Part No.	Series	Qty.	Bolt	T-Nut
3321	10	16	1/4-20 x 1/2" FBHSCS	Economy
3320	15	16	5/16-18 x 11/16" FBHSCS	Economy

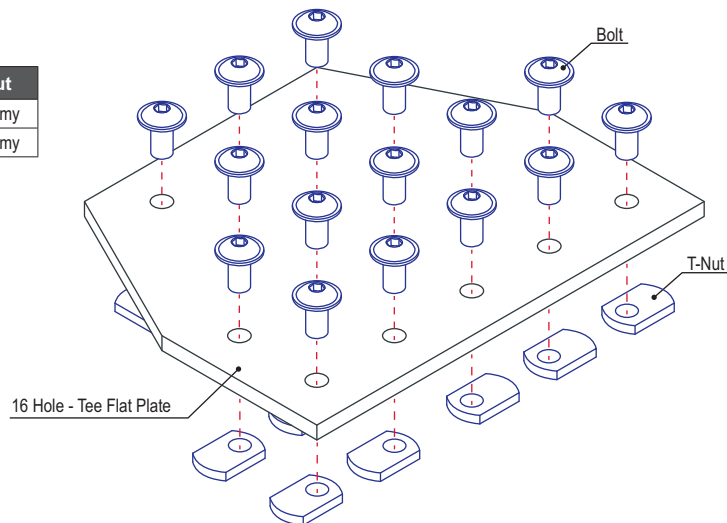

7 Hole - Cross Flat Plate

Part Description:

The 7 hole - cross flat plate is an external fastening method that can be used to join more than two profiles or even create a 4-way connection hub. It provides a strong, long-lasting connection that is easy to assemble and requires no machining services. The 7 hole - cross flat plate is durable and can be repositioned and reused. **Tip:** Use double or triple slide-in economy T-nuts (pg. 364-365) to save time and money. Pre-load your hardware prior to connecting profiles to simplify your assembly.

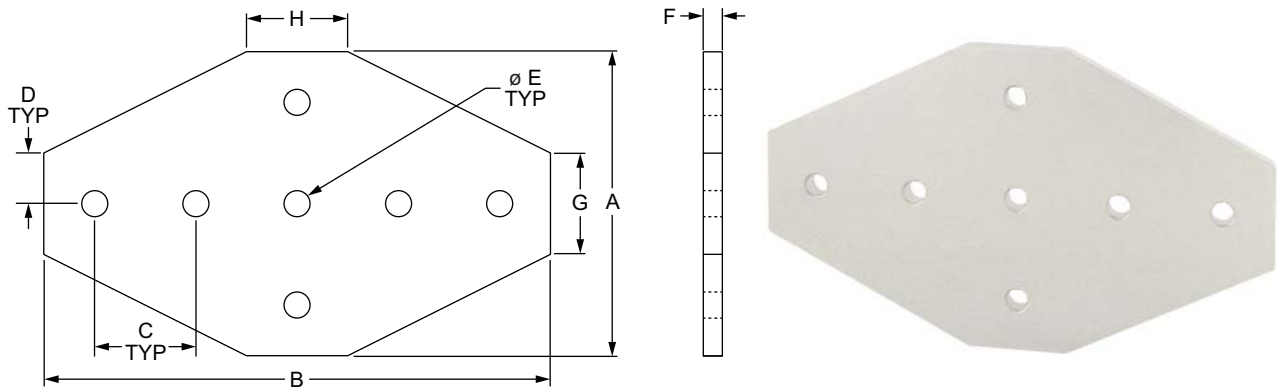

Part No.	Series	Material	Alloy*	Finish	A	B	C	D	E	F	G	H	Weight
4135	10	Aluminum	6105-T5	Clear Anodize	3.000"	5.000"	1.000"	.500"	.257"	.188"	1.000"	1.000"	.187 lb
4135-Black	10			Black Anodize	3.000"	5.000"	1.000"	.500"	.257"	.188"	1.000"	1.000"	.187 lb
4335	15			Clear Anodize	4.500"	7.500"	1.500"	.750"	.328"	.250"	1.500"	1.500"	.569 lb
4335-Black	15			Black Anodize	4.500"	7.500"	1.500"	.750"	.328"	.250"	1.500"	1.500"	.569 lb
25-4135	25			Clear Anodize	75.00mm	125.00mm	25.00mm	12.50mm	6.30mm	4.00mm	25.00mm	25.00mm	.0703 kg
25-4135-Black	25			Black Anodize	75.00mm	125.00mm	25.00mm	12.50mm	6.30mm	4.00mm	25.00mm	25.00mm	.0703 kg
30-4335	30			Clear Anodize	90.00mm	150.00mm	30.00mm	15.00mm	6.30mm	4.00mm	30.00mm	30.00mm	.1025 kg
30-4335-Black	30			Black Anodize	90.00mm	150.00mm	30.00mm	15.00mm	6.30mm	4.00mm	30.00mm	30.00mm	.1025 kg
40-4335	40			Clear Anodize	120.00mm	200.00mm	40.00mm	20.00mm	8.30mm	6.00mm	40.00mm	40.00mm	.2681 kg
40-4335-Black	40			Black Anodize	120.00mm	200.00mm	40.00mm	20.00mm	8.30mm	6.00mm	40.00mm	40.00mm	.2681 kg
45-4335	45			Clear Anodize	135.00mm	225.00mm	45.00mm	22.50mm	8.30mm	6.00mm	45.00mm	45.00mm	.3465 kg
45-4335-Black	45			Black Anodize	135.00mm	225.00mm	45.00mm	22.50mm	8.30mm	6.00mm	45.00mm	45.00mm	.3465 kg

* Or comparable

Suggested Hardware (Mount to T-Slot)

Part No.	Series	Qty.	Bolt	T-Nut
3321	10	7	1/4-20 x 1/2" FBHSCS	Economy
3320	15	7	5/16-18 x 11/16" FBHSCS	Economy
75-3404	25	7	M6 x 10mm BHSCS	Economy
75-3600	30	7	M6 x 12mm BHSCS	Drop-in
75-3422	40	7	M8 x 16mm BHSCS	Economy
75-3619	45	7	M8 x 18mm BHSCS	Drop-in

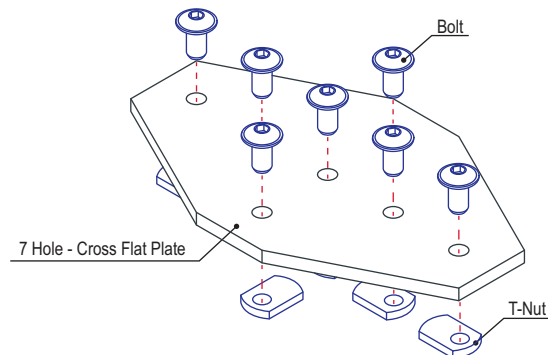



Part Description:

The 12 hole - cross flat plate is an external fastening method that can be used to join more than two profiles or even create a 4-way connection hub. It provides a strong, long-lasting connection that is easy to assemble and requires no machining services. The 12 hole - cross flat plate is durable and can be repositioned and reused. **Tip:** Use double or triple slide-in economy T-nuts (pg. 364-365) to save time and money. Pre-load your hardware prior to connecting profiles to simplify your assembly.

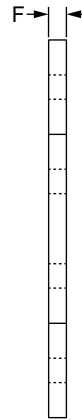
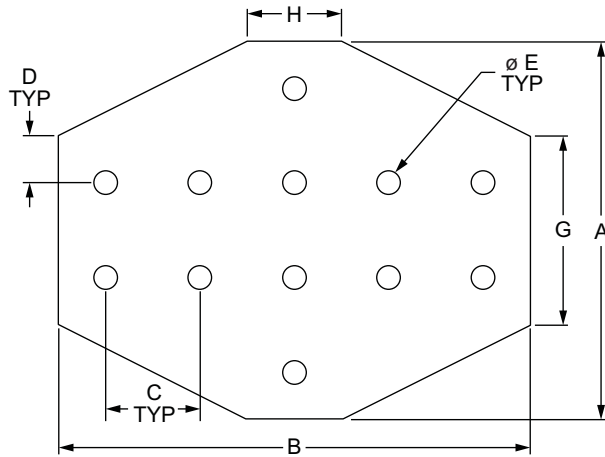

Part No.	Series	Material	Alloy*	Finish	A	B	C	D	E	F	G	H	Weight
4160	10	Aluminum	6105-T5	Clear Anodize	4.000"	5.000"	1.000"	.500"	.257"	.188"	2.000"	1.000"	.272 lb
4160-Black	10			Black Anodize	4.000"	5.000"	1.000"	.500"	.257"	.188"	2.000"	1.000"	.272 lb
4360	15			Clear Anodize	6.000"	7.500"	1.500"	.750"	.328"	.250"	3.000"	1.500"	.860 lb
4360-Black	15			Black Anodize	6.000"	7.500"	1.500"	.750"	.328"	.250"	3.000"	1.500"	.860 lb

* Or comparable

Suggested Hardware (Mount to T-Slot)

Part No.	Series	Qty.	Bolt	T-Nut
3321	10	12	1/4-20 x 1/2" FBHSCS	Economy
3320	15	12	5/16-18 x 11/16" FBHSCS	Economy

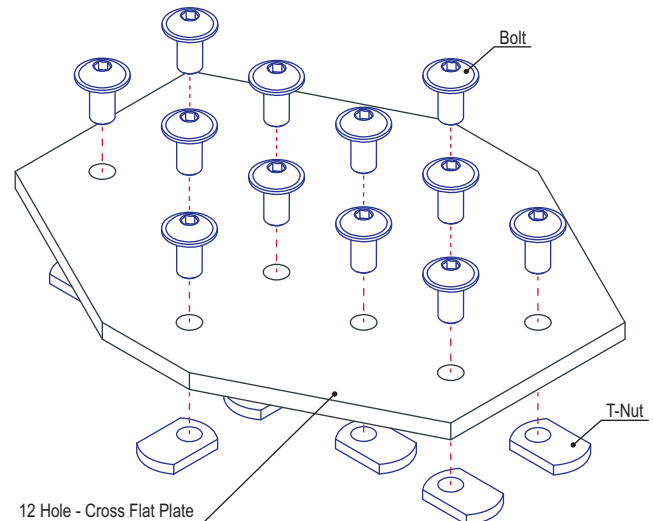

16 Hole - Cross Flat Plate

Part Description:

The 16 hole - cross flat plate is an external fastening method that can be used to join more than two profiles or even create a 4-way connection hub. It provides a strong, long-lasting connection that is easy to assemble and requires no machining services. The 16 hole - cross flat plate is durable and can be repositioned and reused. **Tip:** Use double or triple slide-in economy T-nuts (pg. 364-365) to save time and money. Pre-load your hardware prior to connecting profiles to simplify your assembly.

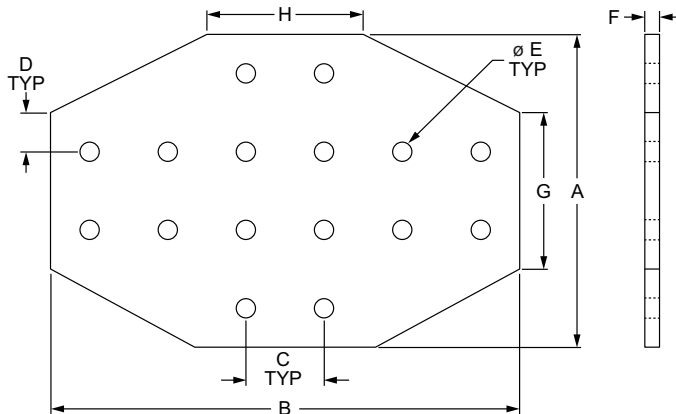

Part No.	Series	Material	Alloy*	Finish	A	B	C	D	E	F	G	H	Weight
4170	10	Aluminum	6105-T5	Clear Anodize	4.000"	6.000"	1.000"	.500"	.257"	.188"	2.000"	2.000"	.340 lb
4170-Black	10			Black Anodize	4.000"	6.000"	1.000"	.500"	.257"	.188"	2.000"	2.000"	.340 lb
4370	15			Clear Anodize	6.000"	9.000"	1.500"	.750"	.328"	.250"	3.000"	3.000"	1.040 lb
4370-Black	15			Black Anodize	6.000"	9.000"	1.500"	.750"	.328"	.250"	3.000"	3.000"	1.040 lb
25-4170	25			Clear Anodize	100.00mm	150.00mm	25.00mm	12.50mm	6.30mm	4.00mm	50.00mm	50.00mm	.1266 kg
25-4170-Black	25			Black Anodize	100.00mm	150.00mm	25.00mm	12.50mm	6.30mm	4.00mm	50.00mm	50.00mm	.1266 kg
40-4370	40			Clear Anodize	160.00mm	240.00mm	40.00mm	20.00mm	8.30mm	6.00mm	80.00mm	80.00mm	.4968 kg
40-4370-Black	40			Black Anodize	160.00mm	240.00mm	40.00mm	20.00mm	8.30mm	6.00mm	80.00mm	80.00mm	.4968 kg

* Or comparable

Suggested Hardware (Mount to T-Slot)

Part No.	Series	Qty.	Bolt	T-Nut
3321	10	16	1/4-20 x 1/2" FBHSCS	Economy
3320	15	16	5/16-18 x 11/16" FBHSCS	Economy
75-3404	25	16	M6 x 10mm BHSCS	Economy
75-3422	40	16	M8 x 16mm BHSCS	Economy

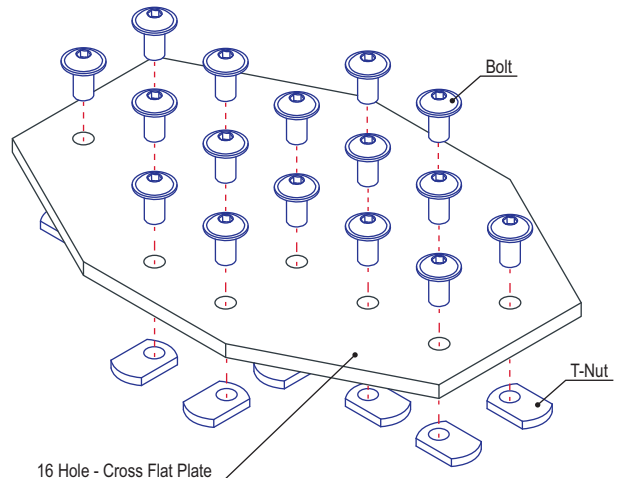



Part Description:

The 20 hole - cross flat plate is an external fastening method that can be used to join more than two profiles or even create a 4-way connection hub. It provides a strong, long-lasting connection that is easy to assemble and requires no machining services. The 20 hole - cross flat plate is durable and can be repositioned and reused. **Tip:** Use double or triple slide-in economy T-nuts (pg. 364-365) to save time and money. Pre-load your hardware prior to connecting profiles to simplify your assembly.

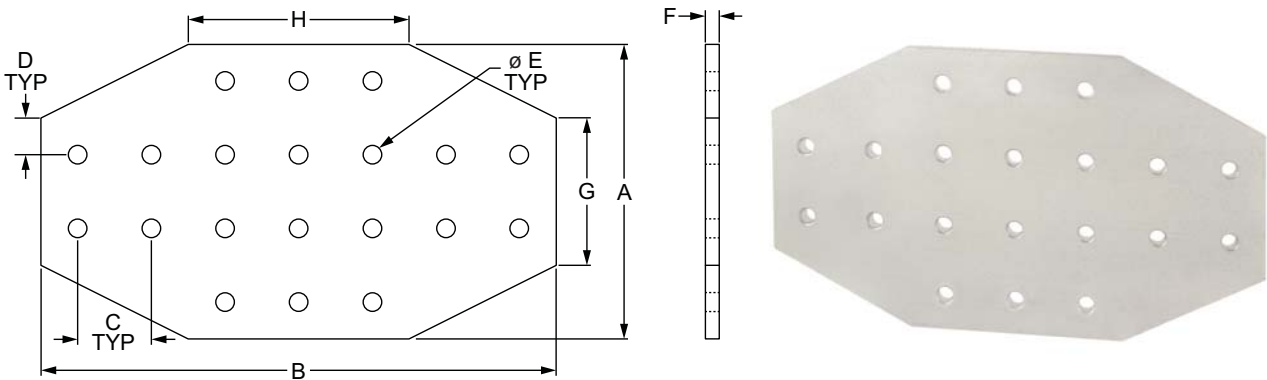

Part No.	Series	Material	Alloy*	Finish	A	B	C	D	E	F	G	H	Weight
4023	10	Aluminum	6105-T5	Clear Anodize	4.000"	7.000"	1.000"	.500"	.257"	.188"	2.000"	3.000"	.410 lb
4023-Black	10			Black Anodize	4.000"	7.000"	1.000"	.500"	.257"	.188"	2.000"	3.000"	.410 lb
4423	15			Clear Anodize	6.000"	10.500"	1.500"	.750"	.328"	.250"	3.000"	4.500"	1.291 lb
4423-Black	15			Black Anodize	6.000"	10.500"	1.500"	.750"	.328"	.250"	3.000"	4.500"	1.291 lb

* Or comparable

Suggested Hardware (Mount to T-Slot)

Part No.	Series	Qty.	Bolt	T-Nut
3321	10	20	1/4-20 x 1/2" FBHSCS	Economy
3320	15	20	5/16-18 x 11/16" FBHSCS	Economy

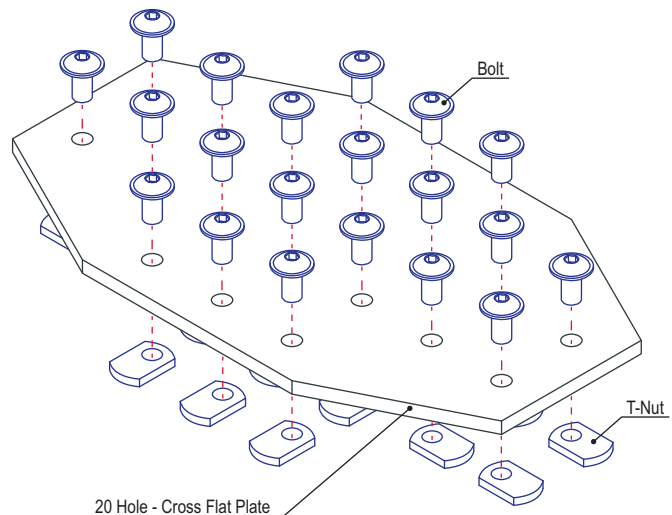

5 Hole - "L" Flat Plate

Part Description:

The 5 hole - "L" flat plate is a strong, external fastening method offering a long-lasting connection. This flat plate creates a 90° angle between profiles and is typically used to form a corner connection. The fastener is flush with the profiles, allowing for a larger clearance area. It requires no machining services, is easy to assemble, and can be reconfigured and reused. **Tip:** Use double or triple slide-in economy T-nuts (pg. 364-365) to save time and money. Pre-load your hardware prior to connecting profiles to simplify your assembly.

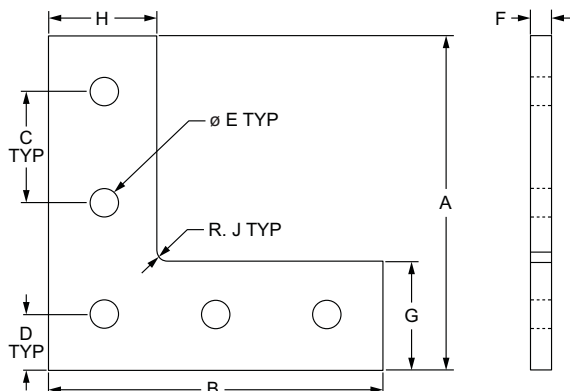

FASTENERS

Part No.	Series	Material	Alloy*	Finish	A	B	C	D	E	F	G	H	J	Weight
4081	10	Aluminum	6105-T5	Clear Anodize	3.000"	3.000"	1.000"	.500"	.257"	.188"	.971"	.971"	.082"	.082 lb
4081-Black	10			Black Anodize	3.000"	3.000"	1.000"	.500"	.257"	.188"	.971"	.971"	.082"	.082 lb
4481	15			Clear Anodize	4.500"	4.500"	1.500"	.750"	.328"	.250"	1.464"	1.464"	.125"	.257 lb
4481-Black	15			Black Anodize	4.500"	4.500"	1.500"	.750"	.328"	.250"	1.464"	1.464"	.125"	.257 lb
NEW 20-4081	20			Clear Anodize	60.00mm	60.00mm	20.00mm	10.00mm	5.56mm	4.00mm	19.00mm	19.00mm	2.38mm	.0193 kg
NEW 20-4081-Black	20			Black Anodize	60.00mm	60.00mm	20.00mm	10.00mm	5.56mm	4.00mm	19.00mm	19.00mm	2.38mm	.0193 kg
NEW 25-4081	25			Clear Anodize	75.00mm	75.00mm	25.00mm	12.50mm	6.30mm	4.00mm	24.00mm	24.00mm	2.38mm	.0308 kg
NEW 25-4081-Black	25			Black Anodize	75.00mm	75.00mm	25.00mm	12.50mm	6.30mm	4.00mm	24.00mm	24.00mm	2.38mm	.0308 kg
NEW 30-4481	30			Clear Anodize	90.00mm	90.00mm	30.00mm	15.00mm	6.81mm	4.00mm	29.00mm	29.00mm	3.18mm	.0452 kg
NEW 30-4481-Black	30			Black Anodize	90.00mm	90.00mm	30.00mm	15.00mm	6.81mm	4.00mm	29.00mm	29.00mm	3.18mm	.0452 kg
NEW 40-4481	40			Clear Anodize	120.00mm	120.00mm	40.00mm	20.00mm	8.33mm	6.00mm	39.00mm	39.00mm	4.76mm	.1224 kg
NEW 40-4481-Black	40			Black Anodize	120.00mm	120.00mm	40.00mm	20.00mm	8.33mm	6.00mm	39.00mm	39.00mm	4.76mm	.1224 kg
NEW 45-4481	45			Clear Anodize	135.00mm	135.00mm	45.00mm	22.50mm	8.33mm	6.00mm	44.00mm	44.00mm	4.76mm	.1564 kg
NEW 45-4481-Black	45			Black Anodize	135.00mm	135.00mm	45.00mm	22.50mm	8.33mm	6.00mm	44.00mm	44.00mm	4.76mm	.1564 kg

* Or comparable

Suggested Hardware (Mount to T-Slot)

Part No.	Series	Qty.	Bolt	T-Nut
3321	10	5	1/4-20 x 1/2" FBHSCS	Economy
3320	15	5	5/16-18 x 11/16" FBHSCS	Economy
75-3656	20	5	M5 x 10mm BHSCS	Economy
75-3404	25	5	M6 x 10mm BHSCS	Economy
75-3600	30	5	M6 x 12mm BHSCS	Drop-in
75-3422	40	5	M8 x 16mm BHSCS	Economy
75-3619	45	5	M8 x 18mm BHSCS	Drop-in

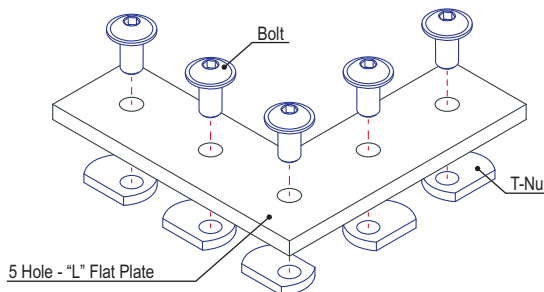

Part Description:

The 5 hole - "T" flat plate is a strong, external fastening method offering a long-lasting connection. This flat plate creates a 90 degree angle between connecting profiles. The fastener is flush with the profiles, allowing for a larger clearance area. It requires no machining services, is easy to assemble, and can be reconfigured and reused. **Tip:** Use double or triple slide-in economy T-nuts (pg. 364-365) to save time and money. Pre-load your hardware prior to connecting profiles to simplify your assembly.

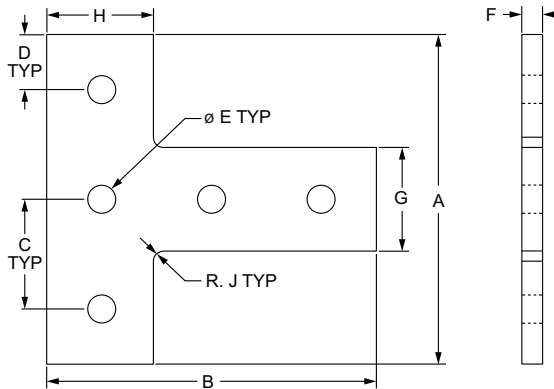

Part No.	Series	Material	Alloy*	Finish	A	B	C	D	E	F	G	H	J	Weight
4080	10	Aluminum	6105-T5	Clear Anodize	3.000"	3.000"	1.000"	.500"	.257"	.188"	.942"	.971"	.094"	.081 lb
4080-Black	10			Black Anodize	3.000"	3.000"	1.000"	.500"	.257"	.188"	.942"	.971"	.094"	.081 lb
4480	15			Clear Anodize	4.500"	4.500"	1.500"	.750"	.328"	.250"	1.426"	1.463"	.125"	.247 lb
4480-Black	15			Black Anodize	4.500"	4.500"	1.500"	.750"	.328"	.250"	1.426"	1.463"	.125"	.247 lb
NEW 20-4080	20			Clear Anodize	60.00mm	60.00mm	20.00mm	10.00mm	5.56mm	4.00mm	18.00mm	19.00mm	2.38mm	.0189 kg
NEW 20-4080-Black	20			Black Anodize	60.00mm	60.00mm	20.00mm	10.00mm	5.56mm	4.00mm	18.00mm	19.00mm	2.38mm	.0189 kg
NEW 25-4080	25			Clear Anodize	75.00mm	75.00mm	25.00mm	12.50mm	6.30mm	4.00mm	23.00mm	24.00mm	2.38mm	.0303 kg
NEW 25-4080-Black	25			Black Anodize	75.00mm	75.00mm	25.00mm	12.50mm	6.30mm	4.00mm	23.00mm	24.00mm	2.38mm	.0303 kg
NEW 30-4480	30			Clear Anodize	90.00mm	90.00mm	30.00mm	15.00mm	6.81mm	4.00mm	28.00mm	29.00mm	3.18mm	.0445 kg
NEW 30-4480-Black	30			Black Anodize	90.00mm	90.00mm	30.00mm	15.00mm	6.81mm	4.00mm	28.00mm	29.00mm	3.18mm	.0445 kg
NEW 40-4480	40			Clear Anodize	120.00mm	120.00mm	40.00mm	20.00mm	8.33mm	6.00mm	38.00mm	39.00mm	4.76mm	.1211 kg
NEW 40-4480-Black	40			Black Anodize	120.00mm	120.00mm	40.00mm	20.00mm	8.33mm	6.00mm	38.00mm	39.00mm	4.76mm	.1211 kg
NEW 45-4480	45			Clear Anodize	135.00mm	135.00mm	45.00mm	22.50mm	8.33mm	6.00mm	43.00mm	44.00mm	4.76mm	.1550 kg
NEW 45-4480-Black	45			Black Anodize	135.00mm	135.00mm	45.00mm	22.50mm	8.33mm	6.00mm	43.00mm	44.00mm	4.76mm	.1550 kg

* Or comparable

Suggested Hardware (Mount to T-Slot)

Part No.	Series	Qty.	Bolt	T-Nut
3321	10	5	1/4-20 x 1/2" FBHSCS	Economy
3320	15	5	5/16-18 x 11/16" FBHSCS	Economy
75-3656	20	5	M5 x 10mm BHSCS	Economy
75-3404	25	5	M6 x 10mm BHSCS	Economy
75-3600	30	5	M6 x 12mm BHSCS	Drop-in
75-3422	40	5	M8 x 16mm BHSCS	Economy
75-3619	45	5	M8 x 18mm BHSCS	Drop-in

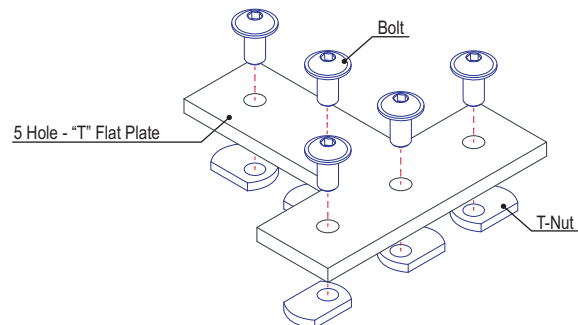

2 Hole - Lite Inside Corner Bracket

Part Description:

The 2 hole - lite inside corner bracket is an external fastening method that creates a 90 degree connection. It is a lightweight bracket that requires no machining services and can provide infinite positioning along the profile T-slot, allowing a large degree of adjustability. The 2 hole - lite inside corner bracket engages the 2-degree drop-lock feature when the assembly bolts are tightened to the required torque. It is a fastening method that can be repositioned and reused.

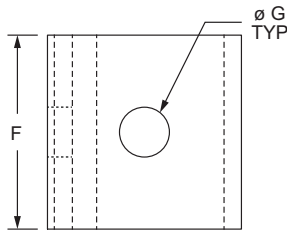
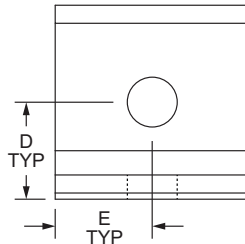
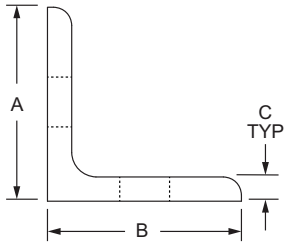

Part No.	Series	Material	Alloy*	Finish	A	B	C	D	E	F	G	Weight
4108	10	Aluminum	6105-T5	Clear Anodize	1.000"	1.000"	.125"	.500"	.500"	1.000"	.257"	.021 lb
4108-Black	10			Black Anodize	1.000"	1.000"	.125"	.500"	.500"	1.000"	.257"	.021 lb
25-4108	25			Clear Anodize	25.00mm	25.00mm	3.00mm	12.50mm	12.50mm	25.00mm	6.30mm	.0086 kg
25-4108-Black	25			Black Anodize	25.00mm	25.00mm	3.00mm	12.50mm	12.50mm	25.00mm	6.30mm	.0086 kg

* Or comparable

Suggested Hardware (Mount to T-Slot)

Part No.	Series	Qty.	Bolt	T-Nut
3386	10	2	1/4-20 x 3/8" FBHSCS	Economy
75-3404	25	2	M6 x 10mm BHSCS	Economy

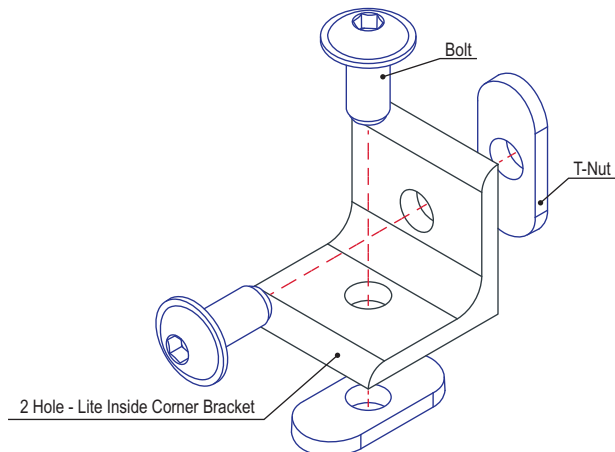

2 Hole - Inside Corner Bracket

Part Description:

The 2 hole - inside corner bracket is an external fastening method that creates a 90 degree connection. It requires no machining services and can provide infinite positioning along the profile T-slot, allowing a large degree of adjustability. It is a fastening method that can be repositioned and reused.

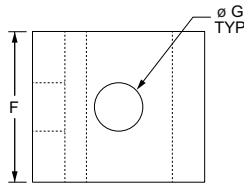
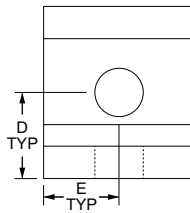
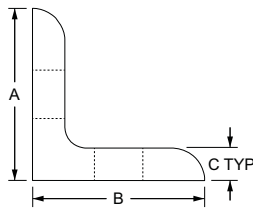

Part No.	Series	Material	Alloy*	Finish	A	B	C	D	E	F	G	Weight	
4119	10	Aluminum	6105-T5	Clear Anodize	1.000"	1.000"	.188"	.500"	.438"	.875"	.281"	.025 lb	
4119-Black	10			Black Anodize	1.000"	1.000"	.188"	.500"	.438"	.438"	.875"	.281"	.025 lb
4302	15			Clear Anodize	1.500"	1.500"	.250"	.750"	.655"	1.310"	.328"	.081 lb	
4302-Black	15			Black Anodize	1.500"	1.500"	.250"	.750"	.655"	1.310"	.328"	.081 lb	
NEW 20-4119	20			Clear Anodize	20.00mm	20.00mm	3.00mm	10.00mm	9.00mm	18.00mm	5.56mm	5.56mm	.0049 kg
NEW 20-4119-Black	20			Black Anodize	20.00mm	20.00mm	3.00mm	10.00mm	9.00mm	18.00mm	5.56mm	5.56mm	.0049 kg
25-4119	25			Clear Anodize	25.00mm	25.00mm	4.00mm	12.50mm	11.00mm	22.00mm	6.80mm	6.80mm	.0095 kg
25-4119-Black	25			Black Anodize	25.00mm	25.00mm	4.00mm	12.50mm	11.00mm	22.00mm	6.80mm	6.80mm	.0095 kg
NEW 30-4302	30			Clear Anodize	30.00mm	30.00mm	4.00mm	15.00mm	13.50mm	27.00mm	6.81mm	6.81mm	.0153 kg
NEW 30-4302-Black	30			Black Anodize	30.00mm	30.00mm	4.00mm	15.00mm	13.50mm	27.00mm	6.81mm	6.81mm	.0153 kg
40-4302	40			Clear Anodize	40.00mm	40.00mm	6.00mm	20.00mm	18.00mm	36.00mm	8.30mm	8.30mm	.0408 kg
40-4302-Black	40			Black Anodize	40.00mm	40.00mm	6.00mm	20.00mm	18.00mm	36.00mm	8.30mm	8.30mm	.0408 kg
NEW 45-4302	45			Clear Anodize	45.00mm	45.00mm	6.00mm	22.50mm	21.00mm	42.00mm	8.33mm	8.33mm	.0543 kg
NEW 45-4302-Black	45			Black Anodize	45.00mm	45.00mm	6.00mm	22.50mm	21.00mm	42.00mm	8.33mm	8.33mm	.0543 kg

* Or comparable

Suggested Hardware (Mount to T-Slot)

Series	Part No.	Qty.	Bolt	Part No.	Qty.	T-Nut
10	3061	2	1/4-20 x 1/2" BHSCS	3382	2	Economy
15	3330	2	5/16-18 x 11/16" FBHSCS	3278	2	Economy
20	11-5308	2	M5 x 8mm BHSCS	14122	2	Economy
25	13-6310	2	M6 x 10mm BHSCS	3859	2	Economy
30	11-6312	2	M6 x 12mm BHSCS	13117	2	Drop-in
40	13-8316	2	M8 x 16mm BHSCS	3838	2	Economy
45	11-8318	2	M8 x 18mm BHSCS	13132	2	Drop-in

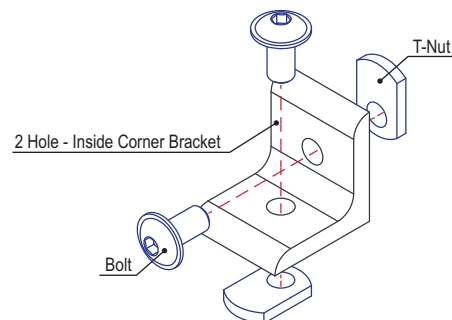

2 Hole - Slotted Inside Corner Bracket

Part Description:

The 2 hole - slotted inside corner bracket is an external fastening method that creates a 90 degree connection. The slotted hole allows for greater adjustability between the connecting profiles. This bracket requires no machining services and can provide infinite positioning along the profile T-slot. The 2 hole - slotted inside corner bracket engages the 2-degree drop-lock feature when the assembly bolts are tightened to the required torque. It is a fastening method that can be repositioned and reused.

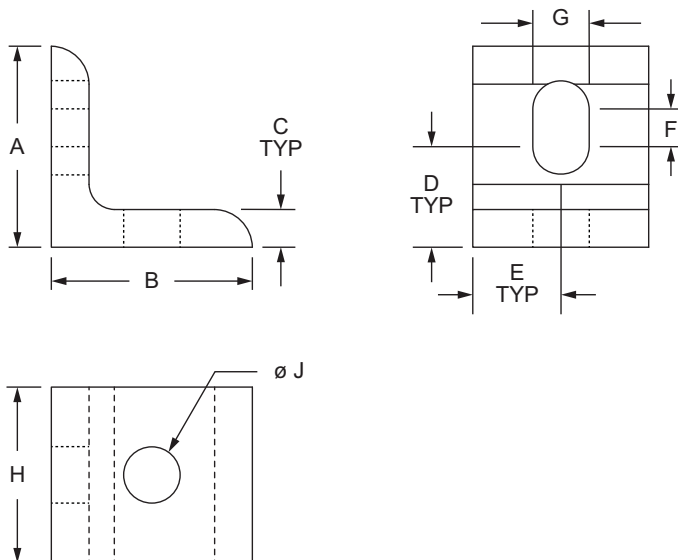

Part No.	Series	Material	Alloy*	Finish	A	B	C	D	E	F	G	H	J	Weight
4265	10	Aluminum	6105-T5	Clear Anodize	1.000"	1.000"	.188"	.500"	.438"	.188"	.281"	.875"	.281"	.024 lb
4265-Black	10			Black Anodize	1.000"	1.000"	.188"	.500"	.438"	.188"	.281"	.875"	.281"	.024 lb
4295	15			Clear Anodize	1.500"	1.500"	.250"	.500"	.656"	.500"	.328"	1.312"	.328"	.078 lb
4295-Black	15			Black Anodize	1.500"	1.500"	.250"	.500"	.656"	.500"	.328"	1.312"	.328"	.078 lb
25-4265	25			Clear Anodize	25.00mm	25.00mm	4.00mm	12.50mm	11.00mm	11.63mm	6.80mm	22.00mm	6.80mm	.0095 kg
25-4265-Black	25			Black Anodize	25.00mm	25.00mm	4.00mm	12.50mm	11.00mm	11.63mm	6.80mm	22.00mm	6.80mm	.0095 kg
40-4295	40			Clear Anodize	40.00mm	40.00mm	6.00mm	14.00mm	18.00mm	14.00mm	8.30mm	36.00mm	8.30mm	.0386 kg
40-4295-Black	40			Black Anodize	40.00mm	40.00mm	6.00mm	14.00mm	18.00mm	14.00mm	8.30mm	36.00mm	8.30mm	.0386 kg

* Or comparable

Suggested Hardware (Mount to T-Slot)

Part No.	Series	Qty.	Bolt	T-Nut
3393	10	2	1/4-20 x 1/2" BHSCS	Economy
3320	15	2	5/16-18 x 11/16" FBHSCS	Economy
75-3404	25	2	M6 x 10mm BHSCS	Economy
75-3422	40	2	M8 x 16mm BHSCS	Economy

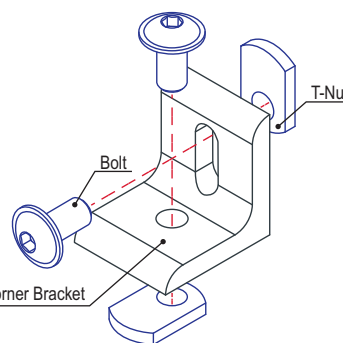

2 Hole - Slotted Inside Corner Bracket

80/20[®] Inc. 2 Hole - Inside Corner Bracket with Single Support

Part Description:

The 2 hole - inside corner bracket with single support is an external fastening method that creates a 90 degree connection. The single support provides additional strength while the slotted mounting holes allow for greater adjustability between the connecting profiles. This bracket requires no machining services and can provide infinite positioning along the profile T-slot.

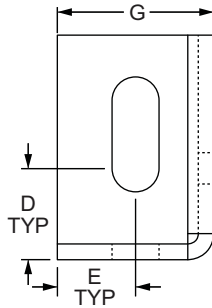
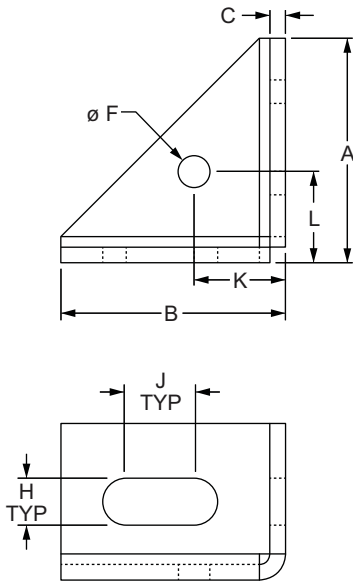

Part No.	Series	Material	Finish	A	B	C	D	E	F	G	H	J	K	L	Weight
14120	15 40	Steel	Zinc	43.00mm	43.00mm	3.00mm	17.50mm	15.00mm	6.00mm	30.00mm	9.00mm	13.00mm	17.50mm	17.50mm	.2626 kg

Suggested Hardware (Mount to T-Slot)

Part No.	Series	Qty.	Bolt	T-Nut
3450	15	2	5/16-18 x 1/2" SHCS	Economy
75-3624	40	2	M8 x 12mm SHCS	Slide-In

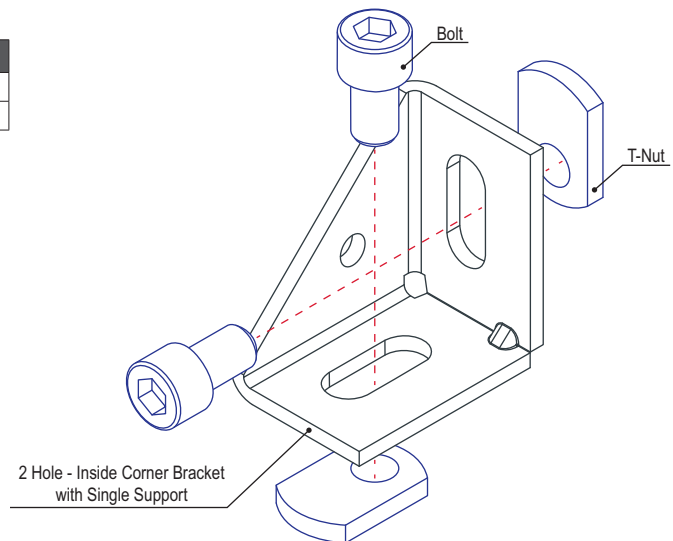

2 Hole - 18mm Slotted Inside Corner Bracket with Dual Support

Part Description:

The 2 hole - 18mm slotted inside corner bracket with dual support is an external, die-cast fastening method that creates a 90 degree connection. The dual support provides additional strength while the slotted holes allow for greater adjustability. Options with a slot tab help line up the profile with the bracket and prevent rotation. It requires no machining and can provide infinite positioning along the profile T-slot. **Additional Information:** Corner bracket covers are available separately and inhibit debris buildup while providing a finished look.

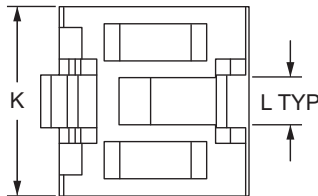
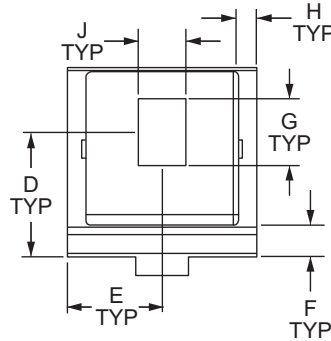
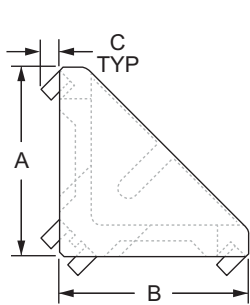

Part No.	Series	Material	Finish	A	B	C	D	E	F	G	H	J	K	L	Weight
14059*	10 20 25	Aluminum	Natural	18.00mm	18.00mm	—	10.50mm	9.00mm	3.00mm	7.00mm	2.00mm	5.30mm	18.00mm	—	.0043 kg
14060	20			18.00mm	18.00mm	2.00mm	10.50mm	9.00mm	3.00mm	7.00mm	2.00mm	5.30mm	18.00mm	4.75mm	.0044 kg
14061	10 25			18.00mm	18.00mm	2.00mm	10.50mm	9.00mm	3.00mm	7.00mm	2.00mm	5.30mm	18.00mm	6.00mm	.0045 kg

* No slot tabs available

Suggested Hardware (Mount to T-Slot)

Part No.	Series	Qty.	Bolt	T-Nut
3457	10	2	10-32 x 3/8" SHCS	Econ. Slide-In
75-3581	20	2	M5 x 8mm BHSCS	Econ. Slide-In
75-3401	25	2	M5 x 10mm SHCS	Econ. Slide-In

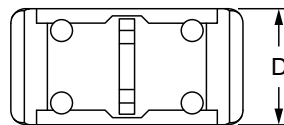
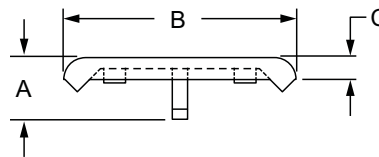

2 hole - 18mm Slotted Inside Corner Bracket Cover Cap

Part No.	Series	Material	A	B	C	D	Weight
12031	10 20 25	PA6 GF 30	9.50mm	28.60mm	2.00mm	17.60mm	.0018 kg

80/20[®] 2 Hole - 20mm Slotted Inside Corner Bracket with Dual Support

Part Description:

The 2 hole - 20mm slotted inside corner bracket with dual support is an external, die-cast fastening method that creates a 90 degree connection. The dual support provides additional strength while the slotted holes allow for greater adjustability. Options with a slot tab help line up the profile with the bracket and prevent rotation. It requires no machining and can provide infinite positioning along the profile T-slot. **Additional Information:** Corner bracket covers are available separately and inhibit debris buildup while providing a finished look.

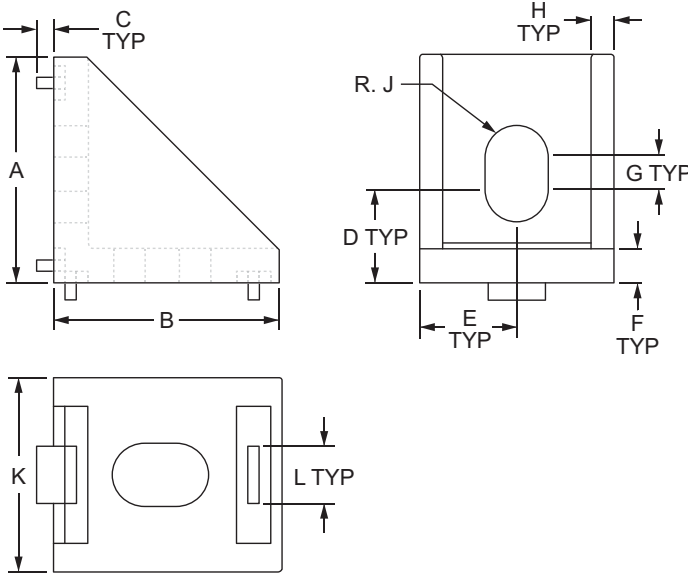

Part No.	Series	Material	Finish	A	B	C	D	E	F	G	H	J	K	L	Weight
14051	20	Zinc	Powder Coat	20.00mm	20.00mm	—	8.00mm	8.50mm	3.00mm	5.00mm	2.40mm	3.10mm	17.00mm	—	.0131 kg
14052	20		Powder Coat	20.00mm	20.00mm	1.00mm	8.00mm	8.50mm	3.00mm	5.00mm	2.40mm	3.10mm	17.00mm	5.00mm	.0104 kg
14053	20		Natural	20.00mm	20.00mm	1.00mm	8.00mm	8.50mm	3.00mm	5.00mm	2.40mm	3.10mm	17.00mm	5.00mm	.0125 kg
14054	10 25		Powder Coat	20.00mm	20.00mm	1.00mm	8.00mm	8.50mm	3.00mm	5.00mm	2.40mm	3.10mm	17.00mm	6.00mm	.0136 kg
14056	20		Natural	20.00mm	20.00mm	—	8.00mm	8.50mm	3.00mm	5.00mm	2.40mm	3.10mm	17.00mm	—	.0116 kg

Suggested Hardware (Mount to T-Slot)

Part No.	Series	Qty.	Bolt	T-Nut
3457	10	2	10-32 x 3/8" SHCS	Econ. Slide-In
75-3581	20	2	M5 x 8mm BHSCS	Econ. Slide-In
75-3401	25	2	M5 x 10mm SHCS	Econ. Slide-In

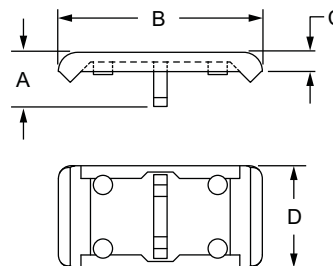

2 Hole - 20mm Slotted Inside Corner Bracket Cover Cap

Part No.	Series	Material	A	B	C	D	Weight
12030	10 20 25	PA6 GF 30	8.50mm	32.00mm	3.00mm	16.00mm	.0018 kg

2 Hole - 27mm Slotted Inside Corner Bracket with Dual Support

Part Description:

The 2 hole - 27mm slotted inside corner bracket with dual support is an external, die-cast fastening method that creates a 90 degree connection. The dual support provides additional strength while the slotted holes allow for greater adjustability. Options with a slot tab help line up the profile with the bracket and prevent rotation. It requires no machining and can provide infinite positioning along the profile T-slot. **Additional Information:** Corner bracket covers are available separately and inhibit debris buildup while providing a finished look.

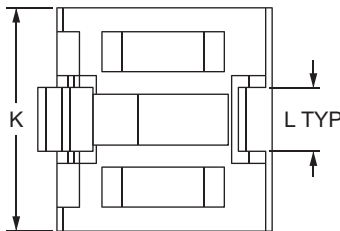
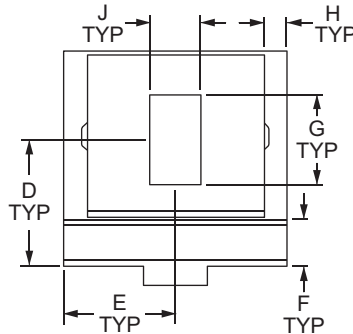
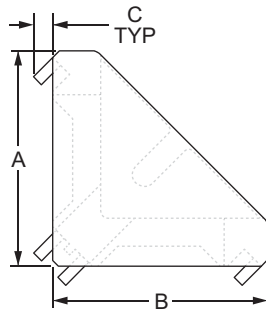

Part No.	Series	Material	Finish	A	B	C	D	E	F	G	H	J	K	L	Weight
14071	30	Aluminum	Natural	27.00mm	27.00mm	—	15.87mm	14.00mm	5.82mm	11.26mm	3.00mm	6.40mm	28.00mm	—	.0184 kg
14073	30			27.00mm	27.00mm	2.40mm	15.87mm	14.00mm	5.82mm	11.26mm	3.00mm	6.40mm	28.00mm	8.00mm	.0186 kg

Suggested Hardware (Mount to T-Slot)

Part No.	Series	Qty.	Bolt	T-Nut
75-3593	30	2	M6 x 14mm SHCS	Drop-In

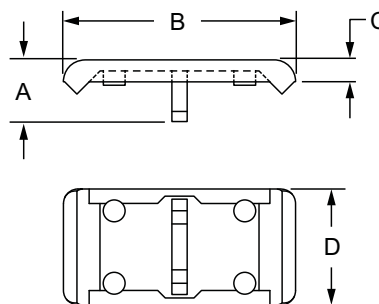

2 hole - 27mm Slotted Inside Corner Bracket Cover Cap

Part No.	Series	Material	A	B	C	D	Weight
12033	30	PA6 GF 30	13.00mm	45.00mm	6.00mm	27.00mm	.0059 kg

80/20[®] 2 Hole - 28mm Slotted Inside Corner Bracket with Dual Support

Part Description:

The 2 hole - 28mm slotted inside corner bracket with dual support is an external, die-cast fastening method that creates a 90 degree connection. The dual support provides additional strength while the slotted holes allow for greater adjustability. Options with a slot tab help line up the profile with the bracket and prevent rotation. It requires no machining and can provide infinite positioning along the profile T-slot. **Additional Information:** Corner bracket covers are available separately and inhibit debris buildup while providing a finished look.

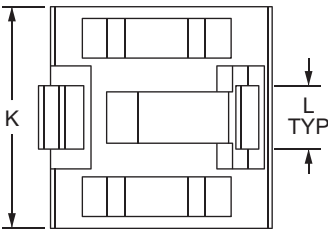
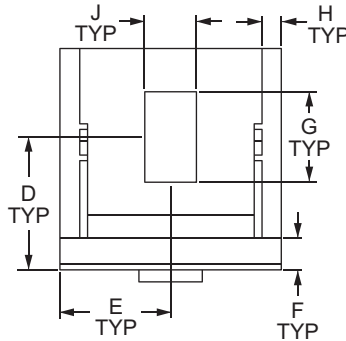
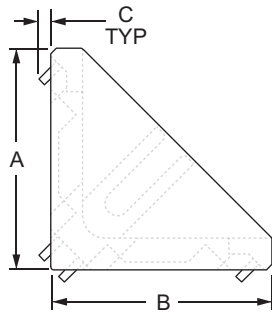

FASTENERS

Part No.	Series	Material	Finish	A	B	C	D	E	F	G	H	J	K	L	Weight
14067	30	Zinc	Natural	28.00mm	28.00mm	—	16.79mm	14.00mm	4.00mm	11.43mm	2.50mm	6.50mm	28.00mm	—	.0382 kg
14062	30		Powder Coat	28.00mm	28.00mm	—	16.79mm	14.00mm	4.00mm	11.43mm	2.50mm	6.50mm	28.00mm	—	.0394 kg
14066	30		Natural	28.00mm	28.00mm	1.49mm	16.79mm	14.00mm	4.00mm	11.43mm	2.50mm	6.50mm	28.00mm	8.00mm	.0386 kg
14065	30		Powder Coat	28.00mm	28.00mm	1.49mm	16.79mm	14.00mm	4.00mm	11.43mm	2.50mm	6.50mm	28.00mm	8.00mm	.0400 kg

Suggested Hardware (Mount to T-Slot)

Part No.	Series	Qty.	Bolt	T-Nut
75-3598	30	2	M6 x 14mm SHCS	Drop-In

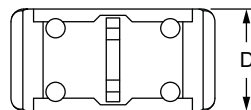
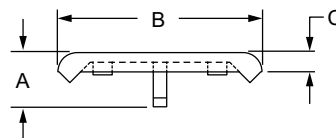

2 Hole - 28mm Slotted Inside Corner Bracket Cover Cap

Part No.	Series	Material	A	B	C	D	Weight
12032	30	PA6 GF 30	14.00mm	44.60mm	4.00mm	27.60mm	.0025 kg

2 Hole - 39mm Slotted Inside Corner Bracket with Dual Support

Part Description:

The 2 hole - 39mm slotted inside corner bracket with dual support is an external, die-cast fastening method that creates a 90 degree connection. The dual support provides additional strength while the slotted holes allow for greater adjustability. Options with a slot tab help line up the profile with the bracket and prevent rotation. It requires no machining and can provide infinite positioning along the profile T-slot. **Additional Information:** Corner bracket covers are available separately and inhibit debris buildup while providing a finished look.

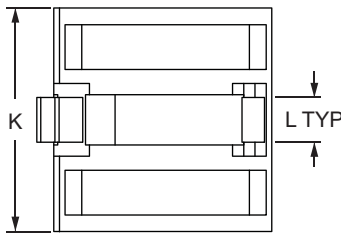
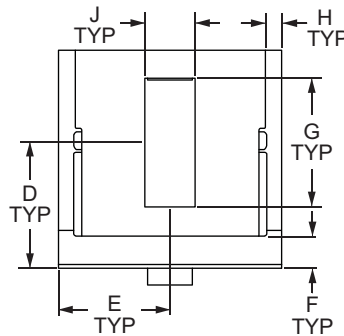
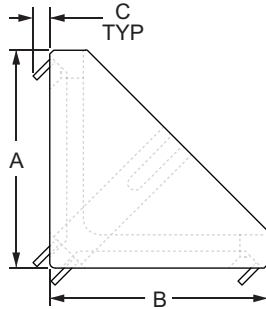

Part No.	Series	Material	Finish	A	B	C	D	E	F	G	H	J	K	L	Weight
14079	40	Zinc	Natural	39.00mm	39.00mm	—	22.47mm	20.00mm	6.00mm	23.05mm	3.00mm	9.00mm	40.00mm	—	.0948 kg
14074	40		Powder Coat	39.00mm	39.00mm	—	22.47mm	20.00mm	6.00mm	23.05mm	3.00mm	9.00mm	40.00mm	—	.0962 kg
14076	40		Natural	39.00mm	39.00mm	3.02mm	22.47mm	20.00mm	6.00mm	23.05mm	3.00mm	9.00mm	40.00mm	8.00mm	.0898 kg
14075	40		Powder Coat	39.00mm	39.00mm	3.02mm	22.47mm	20.00mm	6.00mm	23.05mm	3.00mm	9.00mm	40.00mm	8.00mm	.0981 kg
14078	45		Natural	39.00mm	39.00mm	3.02mm	22.47mm	20.00mm	6.00mm	23.05mm	3.00mm	9.00mm	40.00mm	10.00mm	.0966 kg
14077	45		Powder Coat	39.00mm	39.00mm	3.02mm	22.47mm	20.00mm	6.00mm	23.05mm	3.00mm	9.00mm	40.00mm	10.00mm	.0980 kg

Suggested Hardware (Mount to T-Slot)

Part No.	Series	Qty.	Bolt	T-Nut
75-3625	40	2	M8 x 16mm SHCS	Slide-In
75-3626	45	2	M8 x 18mm SHCS	Drop-In

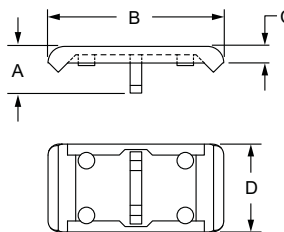

2 Hole - 39mm Slotted Inside Corner Bracket Cover Cap

Part No.	Series	Material	A	B	C	D	Weight
12034	40 45	PA6 GF 30	14.00mm	64.00mm	4.00mm	39.60mm	.0572 kg

80/20® 2 Hole - 42mm Slotted Inside Corner Bracket with Dual Support

Part Description:

The 2 hole- 42mm slotted inside corner bracket with dual support is an external, die-cast fastening method that creates a 90 degree connection. The dual support provides additional strength while the slotted holes allow for greater adjustability. Options with a slot tab help line up the profile with the bracket and prevent rotation. It requires no machining and can provide infinite positioning along the profile T-slot. **Additional Information:** Corner bracket covers are available separately and inhibit debris buildup while providing a finished look.

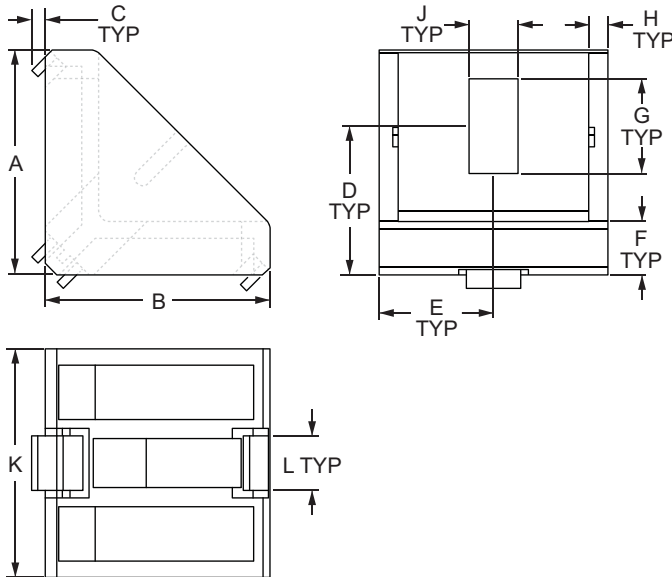

Part No.	Series	Material	Finish	A	B	C	D	E	F	G	H	J	K	L	Weight
14083	45	Aluminum	Natural	41.30mm	41.30mm	—	27.32mm	21.00mm	9.80mm	17.36mm	3.50mm	9.00mm	42.00mm	—	.0500 kg
14085	45	Aluminum		41.30mm	41.30mm	2.46mm	27.32mm	21.00mm	9.80mm	17.36mm	3.50mm	9.00mm	42.00mm	10.00mm	.0513 kg
14092	45	Zinc		41.30mm	41.30mm	2.46mm	27.32mm	21.00mm	9.80mm	17.36mm	3.50mm	9.00mm	42.00mm	10.00mm	.1287 kg

Suggested Hardware (Mount to T-Slot)

Part No.	Series	Qty.	Bolt	T-Nut
75-3630	45	2	M8 x 20mm SHCS	Drop-In

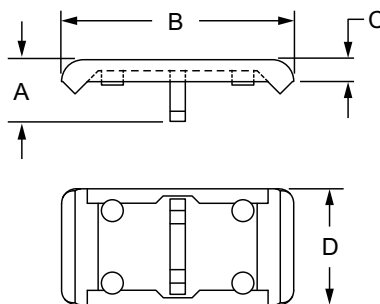

2 hole - 42mm Slotted Inside Corner Bracket Cover Cap

Part No.	Series	Material	A	B	C	D	Weight
12035	45	PA6 GF 30	20.00mm	70.00mm	3.00mm	42.20mm	.0173 kg

3 Hole - Inside Corner Bracket

Part Description:

The 3 hole - inside corner bracket is an external fastening method that creates a 90 degree connection. There are two stacked holes on one side and one hole on the opposite side of the bracket. This fastener requires no machining services and can provide infinite positioning along the profile T-slot, allowing a large degree of adjustability. It is a fastening method that can be repositioned and reused.

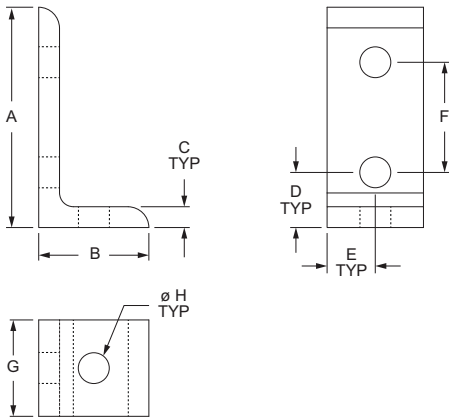

FASTENERS

Part No.	Series	Material	Alloy*	Finish	A	B	C	D	E	F	G	H	Weight	
4176	10	Aluminum	6105-T5	Clear Anodize	2.000"	1.000"	.188"	.500"	.438"	1.000"	.875"	.281"	.039 lb	
4176-Black	10			Black Anodize	2.000"	1.000"	.188"	.500"	.438"	1.000"	.875"	.281"	.039 lb	
4376	15			Clear Anodize	3.000"	1.500"	.250"	.750"	.655"	1.500"	1.310"	.328"	.126 lb	
4376-Black	15			Black Anodize	3.000"	1.500"	.250"	.750"	.655"	1.500"	1.310"	.328"	.126 lb	
NEW 20-4176	20			Clear Anodize	40.00mm	18.00mm	3.00mm	10.00mm	9.00mm	20.00mm	18.00mm	5.56mm	5.56mm	.0076 kg
NEW 20-4176-Black	20			Black Anodize	40.00mm	18.00mm	3.00mm	10.00mm	9.00mm	20.00mm	18.00mm	5.56mm	5.56mm	.0076 kg
25-4176	25			Clear Anodize	50.00mm	25.00mm	4.00mm	12.50mm	11.00mm	25.00mm	22.00mm	6.80mm	6.80mm	.0150 kg
25-4176-Black	25			Black Anodize	50.00mm	25.00mm	4.00mm	12.50mm	11.00mm	25.00mm	22.00mm	6.80mm	6.80mm	.0150 kg
NEW 30-4376	30			Clear Anodize	60.00mm	30.00mm	4.00mm	15.00mm	13.50mm	30.00mm	27.00mm	6.81mm	6.81mm	.0236 kg
NEW 30-4376-Black	30			Black Anodize	60.00mm	30.00mm	4.00mm	15.00mm	13.50mm	30.00mm	27.00mm	6.81mm	6.81mm	.0236 kg
40-4376	40			Clear Anodize	80.00mm	40.00mm	6.00mm	20.00mm	18.00mm	40.00mm	36.00mm	8.30mm	8.30mm	.0617 kg
40-4376-Black	40			Black Anodize	80.00mm	40.00mm	6.00mm	20.00mm	18.00mm	40.00mm	36.00mm	8.30mm	8.30mm	.0617 kg
NEW 45-4376	45			Clear Anodize	90.00mm	45.00mm	6.00mm	22.50mm	21.00mm	45.00mm	42.00mm	8.33mm	8.33mm	.0841 kg
NEW 45-4376-Black	45			Black Anodize	90.00mm	45.00mm	6.00mm	22.50mm	21.00mm	45.00mm	42.00mm	8.33mm	8.33mm	.0841 kg

* Or comparable

Suggested Hardware (Mount to T-Slot)

Series	Part No.	Qty.	Bolt	Part No.	Qty.	T-Nut
10	3061	3	1/4-20 x 1/2" BHSCS	3382	3	Economy
15	3330	3	5/16-18 x 11/16" FBHSCS	3278	3	Economy
20	11-5308	3	M5 x 8mm BHSCS	14122	3	Economy
25	13-6310	3	M6 x 10mm BHSCS	3859	3	Economy
30	11-6312	3	M6 x 12mm BHSCS	13117	3	Drop-in
40	13-8316	3	M8 x 16mm BHSCS	3838	3	Economy
45	11-8318	3	M8 x 18mm BHSCS	13132	3	Drop-in

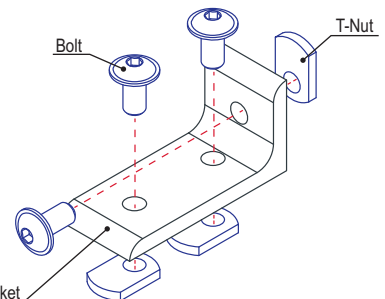

3 Hole - Inside Corner Bracket



Part Description:

The 3 hole - slotted inside corner bracket is an external fastening method that creates a 90 degree connection. There are two stacked holes on one side and one slotted hole on the opposite side of the bracket. The slotted hole allows for a larger degree of adjustability between connecting profiles. This fastener requires no machining services and can provide infinite positioning along the profile T-slot. The 3 hole - slotted inside corner bracket engages the 2-degree drop-lock feature when the assembly bolts are tightened to the required torque. This bracket can be repositioned and reused.

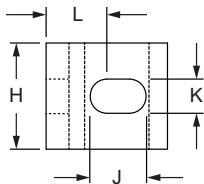
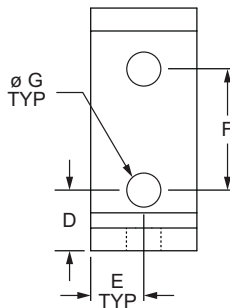
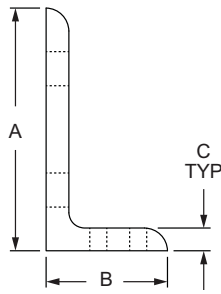

FASTENERS

Part No.	Series	Material	Alloy*	Finish	A	B	C	D	E	F	G	H	J	K	L	Weight
4250	10	Aluminum	6105-T5	Clear Anodize	2.000"	1.000"	.188"	.500"	.438"	1.000"	.281"	.875"	.469"	.281"	.500"	.039 lb
4250-Black	10			Black Anodize	2.000"	1.000"	.188"	.500"	.438"	1.000"	.281"	.875"	.469"	.281"	.500"	.039 lb
4280	15			Clear Anodize	3.000"	1.500"	.250"	.750"	.656"	1.500"	.328"	1.312"	.828"	.328"	.500"	.121 lb
4280-Black	15			Black Anodize	3.000"	1.500"	.250"	.750"	.656"	1.500"	.328"	1.312"	.828"	.328"	.500"	.121 lb
25-4250	25			Clear Anodize	50.00mm	25.00mm	4.00mm	12.50mm	11.00mm	25.00mm	6.80mm	22.00mm	10.80mm	6.80mm	12.50mm	.0145 kg
25-4250-Black	25			Black Anodize	50.00mm	25.00mm	4.00mm	12.50mm	11.00mm	25.00mm	6.80mm	22.00mm	10.80mm	6.80mm	12.50mm	.0145 kg
40-4280	40			Clear Anodize	80.00mm	40.00mm	6.00mm	20.00mm	18.00mm	40.00mm	8.30mm	36.00mm	22.30mm	8.30mm	14.00mm	.0599 kg
40-4280-Black	40			Black Anodize	80.00mm	40.00mm	6.00mm	20.00mm	18.00mm	40.00mm	8.30mm	36.00mm	22.30mm	8.30mm	14.00mm	.0599 kg

* Or comparable

Suggested Hardware (Mount to T-Slot)

Part No.	Series	Qty.	Bolt	T-Nut
3393	10	3	1/4-20 x 1/2" BHSCS	Economy
3320	15	3	5/16-18 x 11/16" FBHSCS	Economy
75-3404	25	3	M6 x 10mm BHSCS	Economy
75-3422	40	3	M8 x 16mm BHSCS	Economy

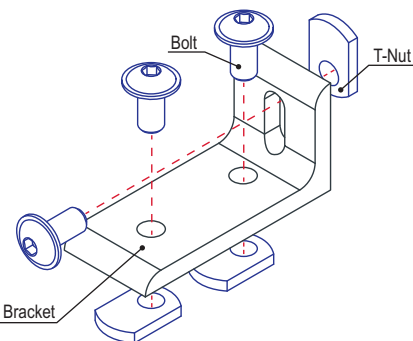

3 Hole - Slotted Inside Corner Bracket

4 Hole - Wide Inside Corner Bracket

Part Description:

The 4 hole - wide inside corner bracket is an external fastening method that creates a 90 degree connection. There are two adjacent holes on each side of the bracket. This fastener requires no machining services and can provide infinite positioning along the profile T-slot, allowing a large degree of adjustability. It is a fastening method that can be repositioned and reused.

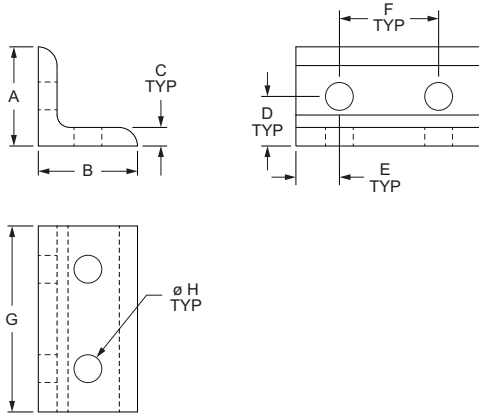

FASTENERS

Part No.	Series	Material	Alloy*	Finish	A	B	C	D	E	F	G	H	Weight
4113	10	Aluminum	6105-T5	Clear Anodize	1.000"	1.000"	.188"	.500"	.438"	1.000"	1.875"	.281"	.054 lb
4113-Black	10			Black Anodize	1.000"	1.000"	.188"	.500"	.438"	1.000"	1.875"	.281"	.054 lb
4303	15			Clear Anodize	1.500"	1.500"	.250"	.750"	.656"	1.500"	2.810"	.328"	.175 lb
4303-Black	15			Black Anodize	1.500"	1.500"	.250"	.750"	.656"	1.500"	2.810"	.328"	.175 lb
NEW 20-4113	20			Clear Anodize	20.00mm	20.00mm	3.00mm	10.00mm	9.00mm	20.00mm	38.00mm	5.56mm	.0104 kg
NEW 20-4113-Black	20			Black Anodize	20.00mm	20.00mm	3.00mm	10.00mm	9.00mm	20.00mm	38.00mm	5.56mm	.0104 kg
25-4113	25			Clear Anodize	25.00mm	25.00mm	4.00mm	12.50mm	11.00mm	25.00mm	47.00mm	6.80mm	.0209 kg
25-4113-Black	25			Black Anodize	25.00mm	25.00mm	4.00mm	12.50mm	11.00mm	25.00mm	47.00mm	6.80mm	.0209 kg
NEW 30-4303	30			Clear Anodize	30.00mm	30.00mm	4.00mm	15.00mm	13.50mm	30.00mm	57.00mm	6.81mm	.0324 kg
NEW 30-4303-Black	30			Black Anodize	30.00mm	30.00mm	4.00mm	15.00mm	13.50mm	30.00mm	57.00mm	6.81mm	.0324 kg
40-4303	40			Clear Anodize	40.00mm	40.00mm	6.00mm	20.00mm	18.00mm	40.00mm	76.00mm	8.30mm	.0862 kg
40-4303-Black	40			Black Anodize	40.00mm	40.00mm	6.00mm	20.00mm	18.00mm	40.00mm	76.00mm	8.30mm	.0862 kg
NEW 45-4303	45			Clear Anodize	45.00mm	45.00mm	6.00mm	22.50mm	21.00mm	45.00mm	87.00mm	8.33mm	.1127 kg
NEW 45-4303-Black	45			Black Anodize	45.00mm	45.00mm	6.00mm	22.50mm	21.00mm	45.00mm	87.00mm	8.33mm	.1127 kg

* Or comparable

Suggested Hardware (Mount to T-Slot)

Series	Part No.	Qty.	Bolt	Part No.	Qty.	T-Nut
10	3061	4	1/4-20 x 1/2" BHSCS	3382	4	Economy
15	3330	4	5/16-18 x 11/16" FBHSCS	3278	4	Economy
20	11-5308	4	M5 x 8mm BHSCS	14122	4	Economy
25	13-6310	4	M6 x 10mm BHSCS	3859	4	Economy
30	11-6312	4	M6 x 12mm BHSCS	13117	4	Drop-in
40	13-8316	4	M8 x 16mm BHSCS	3838	4	Economy
45	11-8318	4	M8 x 18mm BHSCS	13132	4	Drop-in

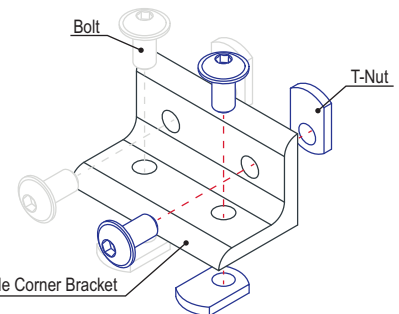

4 Hole - Wide Inside Corner Bracket



4 Hole - Tall Inside Corner Bracket

Part Description:

The 4 hole - tall inside corner bracket is an external fastening method that creates a 90 degree connection. Each side of the bracket has two holes stacked one on top of the other. This fastener requires no machining services and can provide infinite positioning along the profile T-slot, allowing a large degree of adjustability. It is a fastening method that can be repositioned and reused.

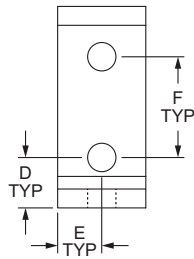
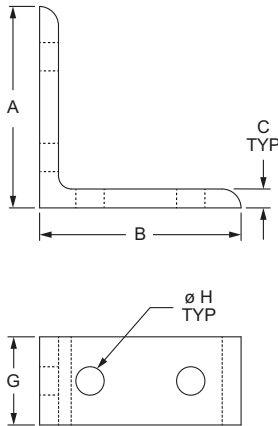

Part No.	Series	Material	Alloy*	Finish	A	B	C	D	E	F	G	H	Weight
4115	10	Aluminum	6105-T5	Clear Anodize	2.000"	2.000"	.188"	.500"	.438"	1.000"	.875"	.281"	.053 lb
4115-Black	10			Black Anodize	2.000"	2.000"	.188"	.500"	.438"	1.000"	.875"	.281"	.053 lb
4301	15			Clear Anodize	3.000"	3.000"	.250"	.750"	.655"	1.500"	1.310"	.328"	.176 lb
4301-Black	15			Black Anodize	3.000"	3.000"	.250"	.750"	.655"	1.500"	1.310"	.328"	.176 lb
25-4115	25			Clear Anodize	50.00mm	50.00mm	4.00mm	12.50mm	11.00mm	25.00mm	22.00mm	6.80mm	.0204 kg
25-4115-Black	25			Black Anodize	50.00mm	50.00mm	4.00mm	12.50mm	11.00mm	25.00mm	22.00mm	6.80mm	.0204 kg
40-4301	40			Clear Anodize	80.00mm	80.00mm	6.00mm	20.00mm	18.00mm	40.00mm	36.00mm	8.30mm	.0853 kg
40-4301-Black	40			Black Anodize	80.00mm	80.00mm	6.00mm	20.00mm	18.00mm	40.00mm	36.00mm	8.30mm	.0853 kg
NEW 45-4301	45			Clear Anodize	90.00mm	90.00mm	6.00mm	22.50mm	21.00mm	45.00mm	42.00mm	8.33mm	.1138 kg
NEW 45-4301-Black	45			Black Anodize	90.00mm	90.00mm	6.00mm	22.50mm	21.00mm	45.00mm	42.00mm	8.33mm	.1138 kg

* Or comparable

Suggested Hardware (Mount to T-Slot)

Part No.	Series	Qty.	Bolt	T-Nut
3393	10	4	1/4-20 x 1/2" BHSCS	Economy
3320	15	4	5/16-18 x 11/16" FBHSCS	Economy
75-3404	25	4	M6 x 10mm BHSCS	Economy
75-3422	40	4	M8 x 16mm BHSCS	Economy
75-3619	45	4	M8 x 18mm BHSCS	Drop-In

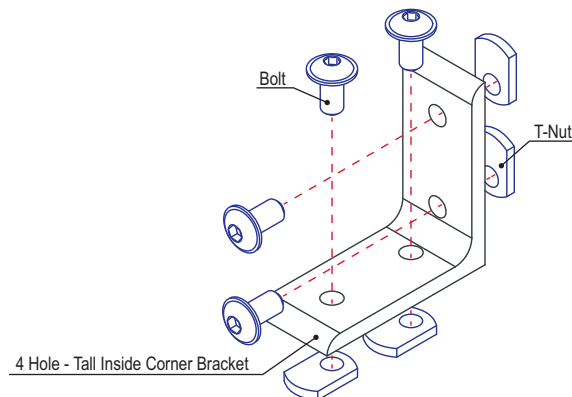

4 Hole - Inside Corner Bracket with Single Support

Part Description:

The 4 hole - inside corner bracket with single support is an external, die-cast fastening method that creates a 90 degree connection. Each side of the bracket has two holes stacked one on top of the other while the single support provides additional strength. The slotted mounting holes allow for greater adjustability between the connecting profiles. Brackets with a slot tab on the support help to line up the profile with the bracket and prevent rotation. It requires no machining services and can provide infinite positioning along the profile T-slot.

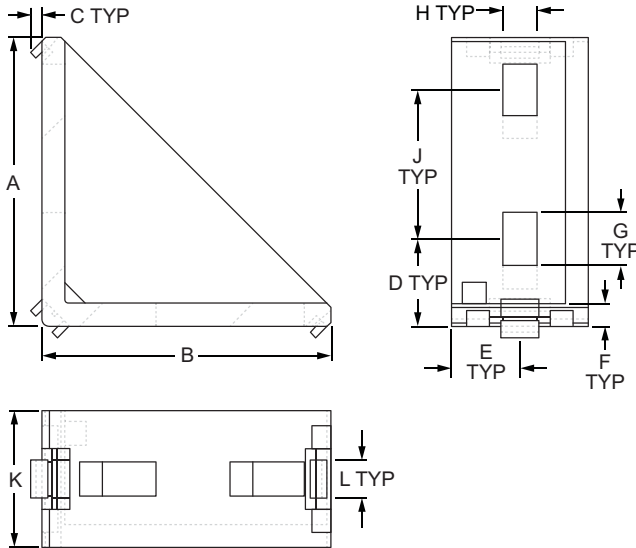

Part No.	Series	Material	Finish	A	B	C	D	E	F	G	H	J	K	L	Weight
14057	20	Aluminum	Natural	38.00mm	38.00mm	1.48mm	11.50mm	9.00mm	3.00mm	7.05mm	4.50mm	19.65mm	18.00mm	5.00mm	.0124 kg
14058	10 25			38.00mm	38.00mm	1.48mm	11.50mm	9.00mm	3.00mm	7.05mm	4.50mm	19.65mm	18.00mm	6.00mm	.0121 kg
14068	30			57.00mm	57.00mm	—	15.62mm	14.00mm	6.00mm	10.80mm	6.20mm	29.90mm	28.00mm	—	.0569 kg
14070	30			57.00mm	57.00mm	1.98mm	15.62mm	14.00mm	6.00mm	10.80mm	6.20mm	29.90mm	28.00mm	8.00mm	.0577 kg
14080	15 40			76.00mm	76.00mm	—	23.50mm	19.00mm	8.50mm	23.00mm	9.00mm	34.50mm	38.00mm	—	.1139 kg
14081	15 40			76.00mm	76.00mm	3.82mm	23.50mm	19.00mm	8.50mm	23.00mm	9.00mm	34.50mm	38.00mm	8.00mm	.1121 kg
14086	45			86.00mm	86.00mm	—	28.00mm	21.50mm	9.50mm	22.90mm	9.00mm	40.00mm	43.00mm	—	.1554 kg
14088	45			86.00mm	86.00mm	3.82mm	28.00mm	21.50mm	9.50mm	22.90mm	9.00mm	40.00mm	43.00mm	10.00mm	.1557 kg

Suggested Hardware (Mount to T-Slot)

Part No.	Series	Qty.	Bolt	T-Nut
3457	10	4	10-32 x 3/8 SHCS	Slide-In
3455	15	4	5/16-18 x 3/4 SHCS	Slide-In
75-3581	20	4	M5 x 8mm BHSCS	Slide-In
75-3401	25	4	M5 x 10mm SHCS	Slide-In
75-3593	30	4	M6 x 14mm SHCS	Drop-In
75-3627	40	4	M8 x 18mm SHCS	Roll-In
75-3630	45	4	M8 x 20mm SHCS	Drop-In

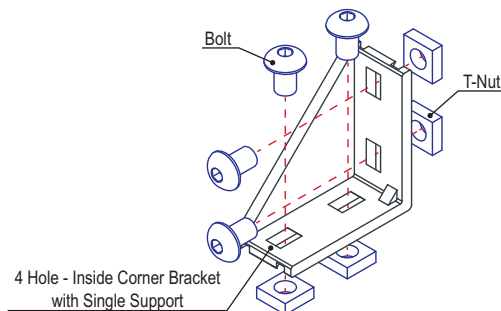

80/20[®] Inc. 4 Hole - Inside Corner Bracket with Dual Support

Part Description:

The 4 hole - inside corner bracket with dual support is an external, die-cast fastening method that creates a 90 degree connection. The dual supports provide additional strength while the slotted holes allow for greater adjustability. Options with a slot tab help line up the profile with the bracket and prevent rotation. It requires no machining and can provide infinite positioning along the profile T-slot. **Additional Information:** Corner bracket covers are available separately and inhibit debris buildup while providing a finished look.

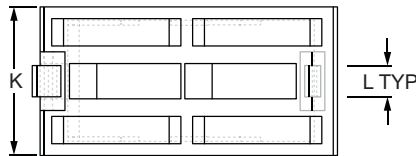
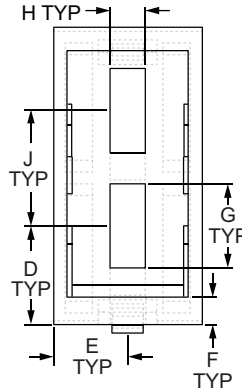
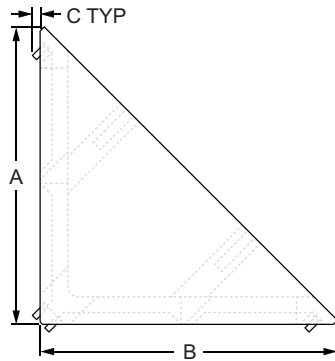

Part No.	Series	Material	Finish	A	B	C	D	E	F	G	H	J	K	L	Weight
14103	15 40 45	Zinc	Natural	76.00mm	76.00mm	—	25.25mm	19.00mm	6.97mm	21.50mm	9.00mm	29.50mm	38.00mm	—	.2622 kg
14098	15 40 45		Powder Coat	76.00mm	76.00mm	—	25.25mm	19.00mm	6.97mm	21.50mm	9.00mm	29.50mm	38.00mm	—	.2705 kg
14100	40		Natural	76.00mm	76.00mm	1.98mm	25.25mm	19.00mm	6.97mm	20.70mm	8.20mm	29.50mm	38.00mm	8.00mm	.2618 kg
14099	40		Powder Coat	76.00mm	76.00mm	1.98mm	25.25mm	19.00mm	6.97mm	20.70mm	8.20mm	29.50mm	38.00mm	8.00mm	.2068 kg
14102	45		Natural	76.00mm	76.00mm	1.98mm	25.25mm	19.00mm	6.97mm	21.50mm	9.00mm	29.50mm	38.00mm	10.00mm	.2673 kg
14101	45		Powder Coat	76.00mm	76.00mm	1.98mm	25.25mm	19.00mm	6.97mm	21.50mm	9.00mm	29.50mm	38.00mm	10.00mm	.2693 kg

Suggested Hardware (Mount to T-Slot)

Part No.	Series	Qty.	Bolt	T-Nut
3455	15	4	5/16-18 x 3/4 SHCS	Slide-In
75-3627	40	4	M8 x18mm SHCS	Slide-In
75-3630	45	4	M8 x 20mm SHCS	Drop-In

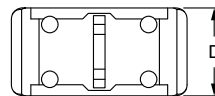
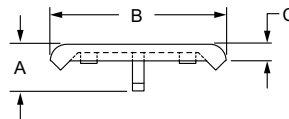

4 Hole - Inside Corner Bracket Cover Cap

Part No.	Series	Material	A	B	C	D	Weight
12038	15 40 45	PA6 GF 30	14.00mm	106.00mm	4.00mm	37.60mm	.0173 kg

4 Hole - Tall Lite Inside Corner Bracket

Part Description:

The 4 hole - tall lite inside corner bracket is an external fastening method that creates a 90 degree connection. Each side of the bracket has two holes stacked one on top of the other. This lightweight fastener requires no machining services and can provide infinite positioning along the profile T-slot, allowing a large degree of adjustability. The 4 hole - tall lite inside corner bracket engages the 2-degree drop-lock feature when the assembly bolts are tightened to the required torque. It is a fastening method that can be repositioned and reused.

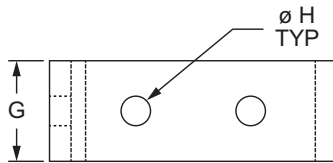
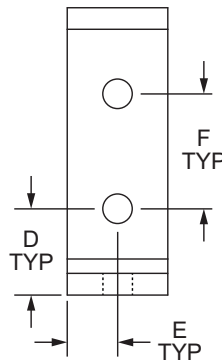
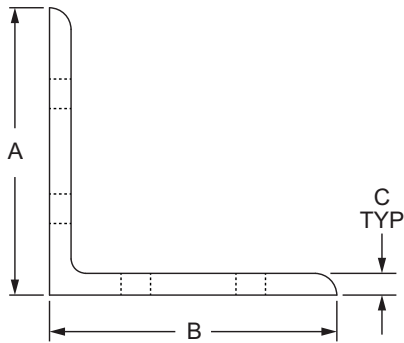

Part No.	Series	Material	Alloy*	Finish	A	B	C	D	E	F	G	H	Weight
4101	10	Aluminum	6105-T5	Clear Anodize	2.500"	2.500"	.188"	.750"	.438"	1.000"	.875"	.257"	.071 lb
4101-Black	10			Black Anodize	2.500"	2.500"	.188"	.750"	.438"	1.000"	.875"	.257"	.071 lb

* Or comparable

Suggested Hardware (Mount to T-Slot)

Part No.	Series	Qty.	Bolt	T-Nut
3393	10	4	1/4-20 x 1/2" BHSCS	Economy

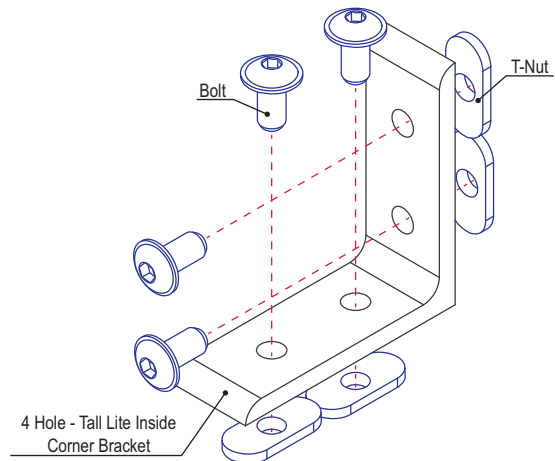



Part Description:

The 4 hole - wide slotted inside corner bracket is an external fastening method that creates a 90 degree connection. There are two adjacent holes on each side of the bracket. Two of the adjacent holes are slotted, allowing for a larger degree of adjustability between connecting profiles. This bracket requires no machining services and can provide infinite positioning along the profile T-slot; it also engages the 2-degree drop-lock feature when the assembly bolts are tightened to the required torque. It is a fastening method that can be repositioned and reused.

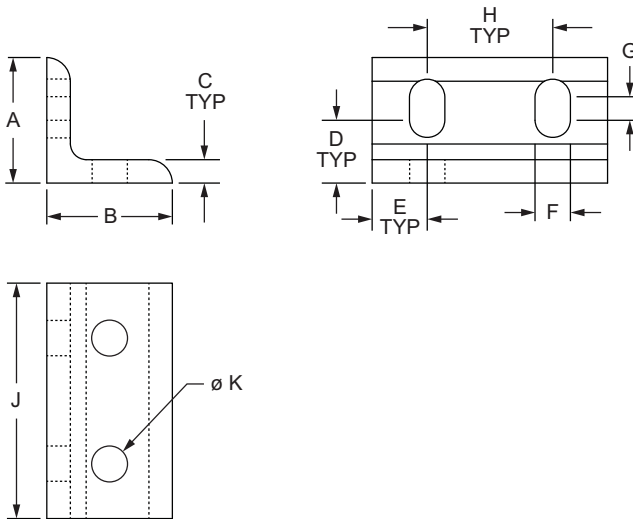

Part No.	Series	Material	Alloy*	Finish	A	B	C	D	E	F	G	H	J	K	Weight
4260	10	Aluminum	6105-T5	Clear Anodize	1.000"	1.000"	.188"	.500"	.438"	.281"	.188"	1.000"	1.875"	.281"	.052 lb
4260-Black	10			Black Anodize	1.000"	1.000"	.188"	.500"	.438"	.281"	.188"	1.000"	1.875"	.281"	.052 lb
4290	15			Clear Anodize	1.500"	1.500"	.250"	.500"	.656"	.328"	.500"	1.500"	2.812"	.328"	.167 lb
4290-Black	15			Black Anodize	1.500"	1.500"	.250"	.500"	.656"	.328"	.500"	1.500"	2.812"	.328"	.167 lb
25-4260	25			Clear Anodize	25.00mm	25.00mm	4.00mm	12.50mm	11.00mm	6.80mm	4.00mm	25.00mm	47.00mm	6.80mm	.0200 kg
25-4260-Black	25			Black Anodize	25.00mm	25.00mm	4.00mm	12.50mm	11.00mm	6.80mm	4.00mm	25.00mm	47.00mm	6.80mm	.0200 kg
40-4290	40			Clear Anodize	40.00mm	40.00mm	6.00mm	14.00mm	18.00mm	8.30mm	14.00mm	40.00mm	76.00mm	8.30mm	.0826 kg
40-4290-Black	40			Black Anodize	40.00mm	40.00mm	6.00mm	14.00mm	18.00mm	8.30mm	14.00mm	40.00mm	76.00mm	8.30mm	.0826 kg

* Or comparable

Suggested Hardware (Mount to T-Slot)

Part No.	Series	Qty.	Bolt	T-Nut
3393	10	4	1/4-20 x 1/2" BHSCS	Economy
3320	15	4	5/16-18 x 11/16" FBHSCS	Economy
75-3404	25	4	M6 x 10mm BHSCS	Economy
75-3422	40	4	M8 x 16mm BHSCS	Economy

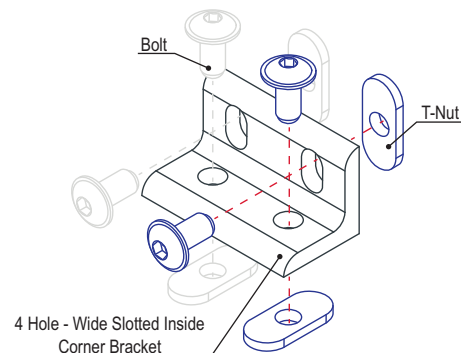

6 Hole - Tall Inside Corner Bracket

Part Description:

The 6 hole - tall inside corner bracket is an external fastening method that creates a 90 degree connection. Each side of the bracket has three holes stacked one on top of the other. This fastener requires no machining services and can provide infinite positioning along the profile T-slot, allowing a large degree of adjustability. The 6 hole - tall inside corner bracket engages the 2-degree drop-lock feature when the assembly bolts are tightened to the required torque. It is a fastening method that can be repositioned and reused.

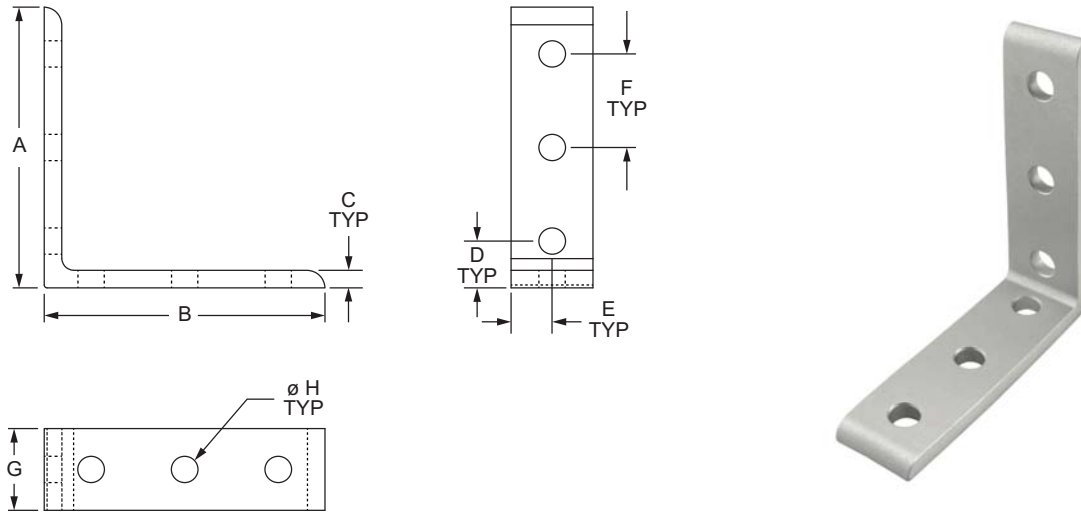

Part No.	Series	Material	Alloy*	Finish	A	B	C	D	E	F	G	H	Weight
4013	10	Aluminum	6105-T5	Clear Anodize	3.000"	3.000"	.188"	.500"	.438"	1.000"	.875"	.281"	.083 lb
4013-Black	10			Black Anodize	3.000"	3.000"	.188"	.500"	.438"	1.000"	.875"	.281"	.083 lb
4413	15			Clear Anodize	4.500"	4.500"	.250"	.750"	.656"	1.500"	1.312"	.328"	.260 lb
4413-Black	15			Black Anodize	4.500"	4.500"	.250"	.750"	.656"	1.500"	1.312"	.328"	.260 lb

* Or comparable

Suggested Hardware (Mount to T-Slot)

Part No.	Series	Qty.	Bolt	T-Nut
3393	10	6	1/4-20 x 1/2" BHSCS	Economy
3320	15	6	5/16-18 x 11/16 FBHSCS	Economy

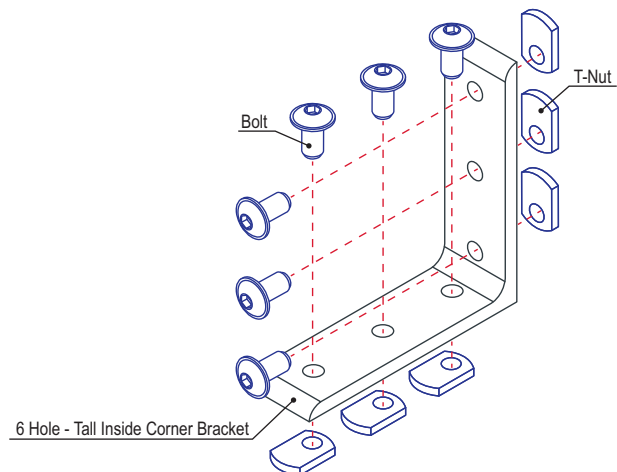



Part Description:

The 6 hole - wide 2x4 inside corner bracket is an external fastening method that creates a 90 degree connection. One side of the bracket has two adjacent holes and the second side has four holes comprised of two rows and two columns. This fastener requires no machining services and can provide infinite positioning along the profile T-slot, allowing a large degree of adjustability. It engages the 2-degree drop-lock feature when the assembly bolts are tightened to the required torque and can also be repositioned and reused.

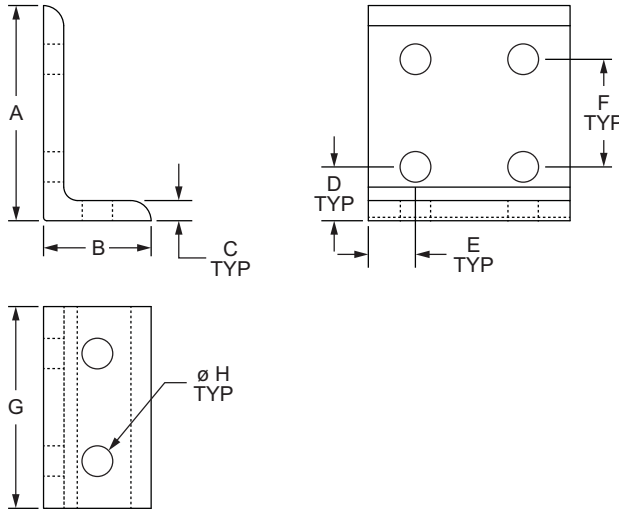

Part No.	Series	Material	Alloy*	Finish	A	B	C	D	E	F	G	H	Weight
4175	10	Aluminum	6105-T5	Clear Anodize	2.000"	1.000"	.188"	.500"	.437"	1.000"	1.875"	.281"	.085 lb
4175-Black	10			Black Anodize	2.000"	1.000"	.188"	.500"	.437"	1.000"	1.875"	.281"	.085 lb
4375	15			Clear Anodize	3.000"	1.500"	.250"	.750"	.654"	1.500"	2.810"	.328"	.277 lb
4375-Black	15			Black Anodize	3.000"	1.500"	.250"	.750"	.654"	1.500"	2.810"	.328"	.277 lb
25-4175	25			Clear Anodize	50.00mm	25.00mm	4.00mm	12.50mm	11.00mm	25.00mm	47.00mm	6.80mm	.0322 kg
25-4175-Black	25			Black Anodize	50.00mm	25.00mm	4.00mm	12.50mm	11.00mm	25.00mm	47.00mm	6.80mm	.0322 kg
40-4375	40			Clear Anodize	80.00mm	40.00mm	6.00mm	20.00mm	18.00mm	40.00mm	76.00mm	8.30mm	.1320 kg
40-4375-Black	40			Black Anodize	80.00mm	40.00mm	6.00mm	20.00mm	18.00mm	40.00mm	76.00mm	8.30mm	.1320 kg

* Or comparable

Suggested Hardware (Mount to T-Slot)

Part No.	Series	Qty.	Bolt	T-Nut
3393	10	6	1/4-20 x 1/2" BHSCS	Economy
3320	15	6	5/16-18 x 11/16 FBHSCS	Economy
75-3404	25	6	M6 x 10mm BHSCS	Economy
75-3422	40	6	M8 x 16mm BHSCS	Economy

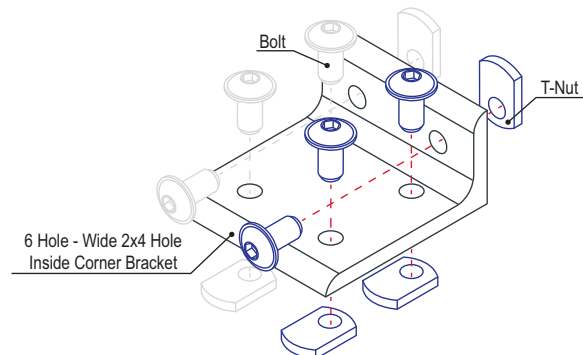

6 Hole - Wide 2x4 Slotted Inside Corner Bracket

Part Description:

The 6 hole - wide 2x4 slotted inside corner bracket is an external fastening method that creates a 90 degree connection. One side of the bracket has two adjacent holes and the second side has four holes comprised of two rows and two columns. The two adjacent holes are slotted, allowing for a larger degree in adjustability between connecting profiles. This fastener requires no machining services and can provide infinite positioning along the profile T-slot, allowing a large degree of adjustability. It engages the 2-degree drop-lock feature when the assembly bolts are tightened to the required torque and can also be repositioned and reused.

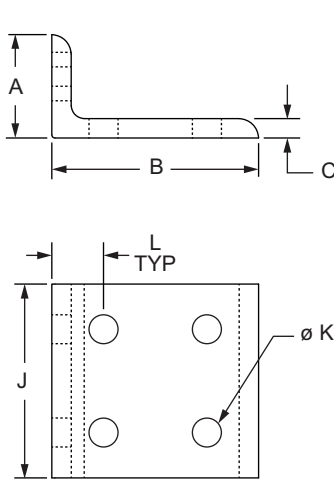

Part No.	Series	Material	Alloy*	Finish	A	B	C	D	E	F	G	H	J	K	L	Weight
4286	10	Aluminum	6105-T5	Clear Anodize	1.000"	2.000"	.188"	.500"	.438"	1.000"	.188"	.281"	1.875"	.281"	.500"	.084 lb
4286-Black	10			Black Anodize	1.000"	2.000"	.188"	.500"	.438"	1.000"	.188"	.281"	1.875"	.281"	.500"	.084 lb
4285	15			Clear Anodize	1.500"	3.000"	.250"	.500"	.656"	1.500"	.500"	.328"	2.810"	.328"	.750"	.262 lb
4285-Black	15			Black Anodize	1.500"	3.000"	.250"	.500"	.656"	1.500"	.500"	.328"	2.810"	.328"	.750"	.262 lb
25-4286	25			Clear Anodize	25.00mm	50.00mm	4.00mm	12.50mm	11.00mm	25.00mm	4.00mm	6.80mm	47.00mm	6.80mm	12.50mm	.0318 kg
25-4286-Black	25			Black Anodize	25.00mm	50.00mm	4.00mm	12.50mm	11.00mm	25.00mm	4.00mm	6.80mm	47.00mm	6.80mm	12.50mm	.0318 kg
40-4285	40			Clear Anodize	40.00mm	80.00mm	6.00mm	14.00mm	18.00mm	40.00mm	14.00mm	8.30mm	76.00mm	8.30mm	20.00mm	.1279 kg
40-4285-Black	40			Black Anodize	40.00mm	80.00mm	6.00mm	14.00mm	18.00mm	40.00mm	14.00mm	8.30mm	76.00mm	8.30mm	20.00mm	.1279 kg

* Or comparable

Suggested Hardware (Mount to T-Slot)

Part No.	Series	Qty.	Bolt	T-Nut
3393	10	6	1/4-20 x 1/2" BHSCS	Economy
3320	15	6	5/16-18 x 11/16 FBHSCS	Economy
75-3404	25	6	M6 x 10mm BHSCS	Economy
75-3422	40	6	M8 x 16mm BHSCS	Economy

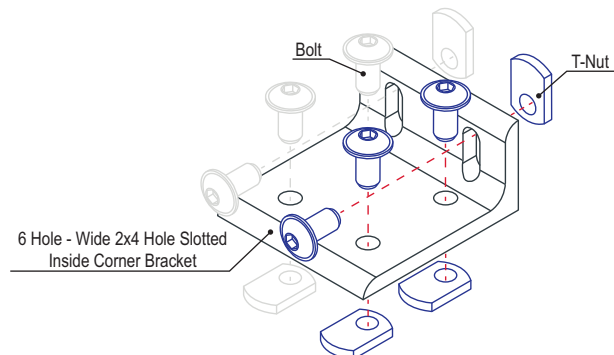



Part Description:

The 6 hole - wide 3x3 inside corner bracket is an external fastening method that creates a 90 degree connection. There are three adjacent holes on each side of the bracket. It requires no machining services and can provide infinite positioning along the profile T-slot, allowing a large degree of adjustability. The bracket engages the 2-degree drop-lock feature when the assembly bolts are tightened to the required torque. It is a fastening method that can be repositioned and reused.

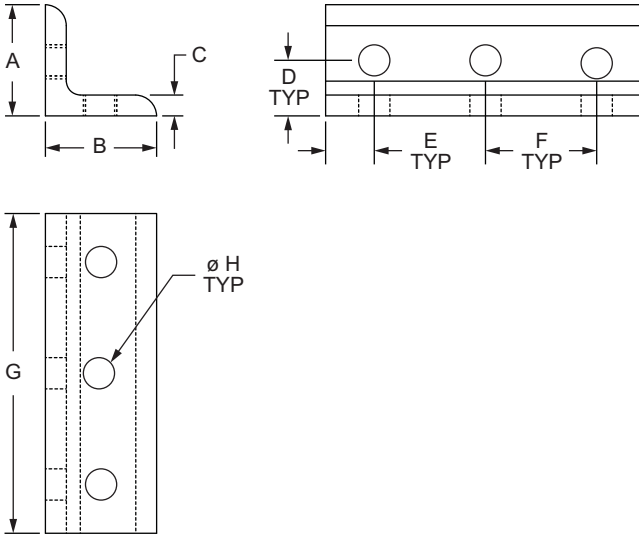

Part No.	Series	Material	Alloy*	Finish	A	B	C	D	E	F	G	H	Weight
4015	10	Aluminum	6105-T5	Clear Anodize	1.000"	1.000"	.188"	.500"	.437"	1.000"	2.875"	.281"	.083 lb
4015-Black	10			Black Anodize	1.000"	1.000"	.188"	.500"	.437"	1.000"	2.875"	.281"	.083 lb
4415	15			Clear Anodize	1.500"	1.500"	.250"	.750"	.656"	1.500"	4.310"	.328"	.268 lb
4415-Black	15			Black Anodize	1.500"	1.500"	.250"	.750"	.656"	1.500"	4.310"	.328"	.268 lb

* Or comparable

Suggested Hardware (Mount to T-Slot)

Part No.	Series	Qty.	Bolt	T-Nut
3393	10	6	1/4-20 x 1/2" BHSCS	Economy
3320	15	6	5/16-18 x 11/16 FBHSCS	Economy

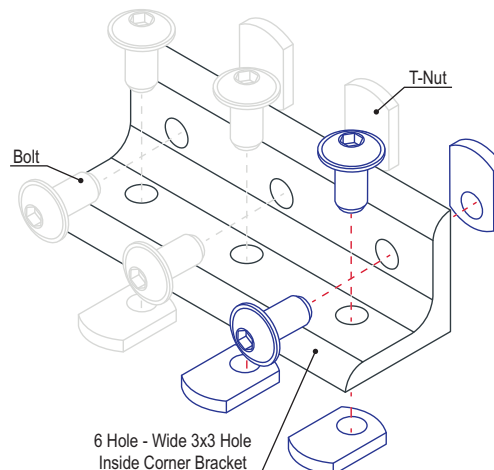

6 Hole - Center Inside Corner Bracket

Part Description:

The 6 hole - center inside corner bracket is an external fastening method that creates a 90 degree connection. One side of the bracket has four holes comprised of two rows and two columns while the second side has two centered, stacked holes. This bracket can be used to connect profiles that are within the same series but of different sizes. It requires no machining services and can provide infinite positioning along the profile T-slot, allowing a large degree of adjustability. The 6 hole - center inside corner bracket engages the 2-degree drop-lock feature when the assembly bolts are tightened to the required torque. It is a fastening method that can be repositioned and reused.

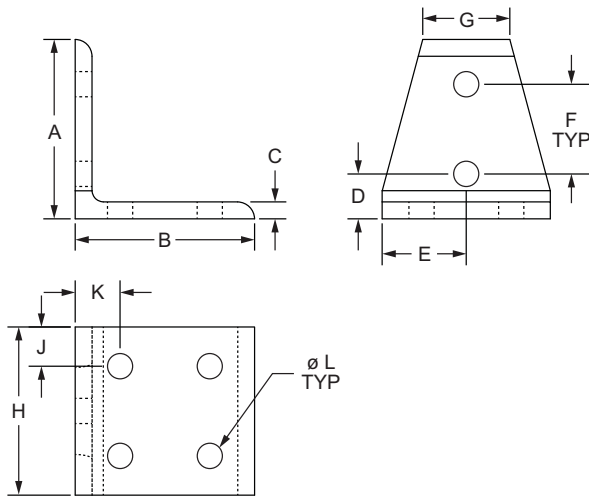

Part No.	Series	Material	Alloy*	Finish	A	B	C	D	E	F	G	H	J	K	L	Weight	
4111	10	Aluminum	6105-T5	Clear Anodize	2.000"	2.000"	.188"	.500"	.937"	1.000"	.970"	1.875"	.438"	.500"	.281"	.106 lb	
4111-Black	10			Black Anodize	2.000"	2.000"	.188"	.500"	.937"	1.000"	.970"	1.875"	.438"	.500"	.281"	.106 lb	
4311	15			Clear Anodize	3.000"	3.000"	.250"	.750"	1.405"	1.500"	1.310"	2.810"	.654"	.750"	.328"	.338 lb	
4311-Black	15			Black Anodize	3.000"	3.000"	.250"	.750"	1.405"	1.500"	1.310"	2.810"	.654"	.750"	.328"	.338 lb	
25-4111	25			Clear Anodize	50.00mm	50.00mm	4.00mm	12.50mm	23.50mm	25.00mm	25.00mm	25.00mm	47.00mm	11.00mm	12.50mm	6.80mm	.0399 kg
25-4111-Black	25			Black Anodize	50.00mm	50.00mm	4.00mm	12.50mm	23.50mm	25.00mm	25.00mm	25.00mm	47.00mm	11.00mm	12.50mm	6.80mm	.0399 kg
40-4311	40			Clear Anodize	80.00mm	80.00mm	6.00mm	20.00mm	38.00mm	40.00mm	36.00mm	76.00mm	18.00mm	20.00mm	8.30mm	.1606 kg	
40-4311-Black	40			Black Anodize	80.00mm	80.00mm	6.00mm	20.00mm	38.00mm	40.00mm	36.00mm	76.00mm	18.00mm	20.00mm	8.30mm	.1606 kg	

* Or comparable

Suggested Hardware (Mount to T-Slot)

Part No.	Series	Qty.	Bolt	T-Nut
3393	10	6	1/4-20 x 1/2" BHSCS	Economy
3320	15	6	5/16-18 x 11/16 FBHSCS	Economy
75-3404	25	6	M6 x 10mm BHSCS	Economy
75-3422	40	6	M8 x 16mm BHSCS	Economy

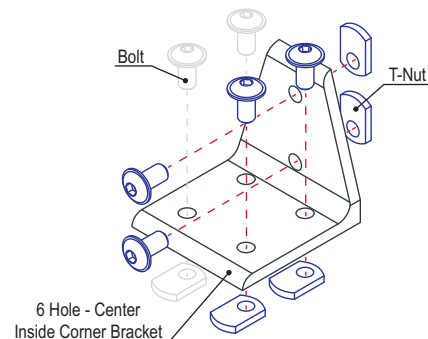



Part Description:

The 6 hole - left aligned inside corner bracket is an external fastening method that creates a 90 degree connection. One side of the bracket has four holes comprised of two rows and two columns while the second side has two left-aligned, stacked holes. This bracket can be used to connect profiles that are within the same series but of different sizes. It requires no machining services and can provide infinite positioning along the profile T-slot, allowing a large degree of adjustability. The 6 hole - left aligned inside corner bracket engages the 2-degree drop-lock feature when the assembly bolts are tightened to the required torque. It is a fastening method that can be repositioned and reused.

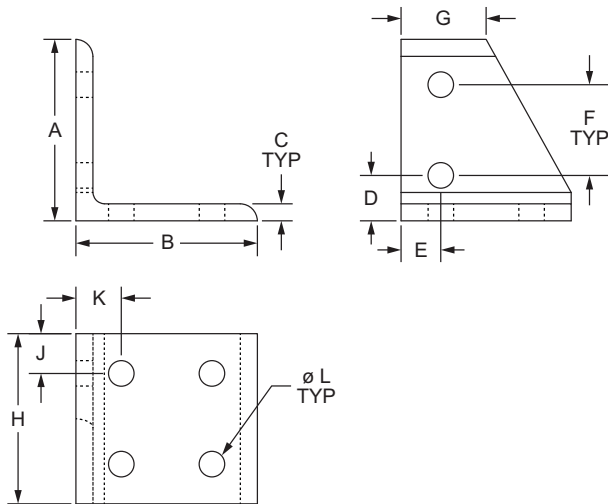

Part No.	Series	Material	Alloy*	Finish	A	B	C	D	E	F	G	H	J	K	L	Weight
4122	10	Aluminum	6105-T5	Clear Anodize	2.000"	2.000"	.188"	.500"	.437"	1.000"	.937"	1.875"	.437"	.500"	.281"	.105 lb
4122-Black	10			Black Anodize	2.000"	2.000"	.188"	.500"	.437"	1.000"	.937"	1.875"	.437"	.500"	.281"	.105 lb
4309	15			Clear Anodize	3.000"	3.000"	.250"	.750"	.656"	1.500"	1.310"	2.810"	.656"	.750"	.328"	.324 lb
4309-Black	15			Black Anodize	3.000"	3.000"	.250"	.750"	.656"	1.500"	1.310"	2.810"	.656"	.750"	.328"	.324 lb
40-4309	40			Clear Anodize	80.00mm	80.00mm	6.00mm	20.00mm	18.00mm	40.00mm	36.00mm	76.00mm	18.00mm	20.00mm	8.30mm	.1601 kg
40-4309-Black	40			Black Anodize	80.00mm	80.00mm	6.00mm	20.00mm	18.00mm	40.00mm	36.00mm	76.00mm	18.00mm	20.00mm	8.30mm	.1601 kg

* Or comparable

Suggested Hardware (Mount to T-Slot)

Part No.	Series	Qty.	Bolt	T-Nut
3393	10	6	1/4-20 x 1/2" BHSCS	Economy
3320	15	6	5/16-18 x 11/16 FBHSCS	Economy
75-3422	40	6	M8 x 16mm BHSCS	Economy

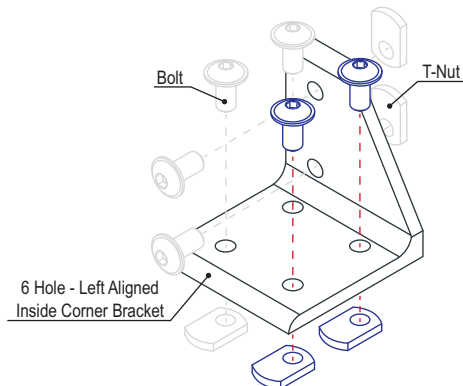

6 Hole - Right Aligned Inside Corner Bracket

Part Description:

The 6 hole - right aligned inside corner bracket is an external fastening method that creates a 90 degree connection. One side of the bracket has four holes comprised of two rows and two columns while the second side has two right-aligned, stacked holes. This bracket can be used to connect profiles that are within the same series but of different sizes. It requires no machining services and can provide infinite positioning along the profile T-slot, allowing a large degree of adjustability. The 6 hole - right aligned inside corner bracket engages the 2-degree drop-lock feature when the assembly bolts are tightened to the required torque. It is a fastening method that can be repositioned and reused.

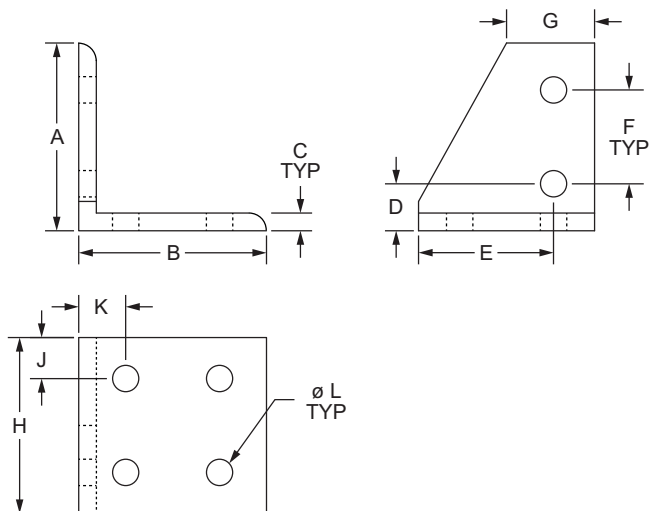

Part No.	Series	Material	Alloy*	Finish	A	B	C	D	E	F	G	H	J	K	L	Weight	
4121	10	Aluminum	6105-T5	Clear Anodize	2.000"	2.000"	.188"	.500"	1.437"	1.000"	.938"	1.875"	.437"	.500"	.281"	.106 lb	
4121-Black	10			Black Anodize	2.000"	2.000"	.188"	.500"	1.437"	1.000"	.938"	1.875"	.437"	.500"	.281"	.106 lb	
4308	15			Clear Anodize	3.000"	3.000"	.250"	.750"	2.156"	1.500"	1.310"	2.810"	.656"	.750"	.328"	.326 lb	
4308-Black	15			Black Anodize	3.000"	3.000"	.250"	.750"	2.156"	1.500"	1.310"	2.810"	.656"	.750"	.328"	.326 lb	
40-4308	40			Clear Anodize	80.00mm	80.00mm	6.00mm	20.00mm	58.00mm	40.00mm	36.00mm	76.00mm	18.00mm	20.00mm	8.30mm	8.30mm	.1597 kg
40-4308-Black	40			Black Anodize	80.00mm	80.00mm	6.00mm	20.00mm	58.00mm	40.00mm	36.00mm	76.00mm	18.00mm	20.00mm	8.30mm	8.30mm	.1597 kg

* Or comparable

Suggested Hardware (Mount to T-Slot)

Part No.	Series	Qty.	Bolt	T-Nut
3393	10	6	1/4-20 x 1/2" BHSCS	Economy
3320	15	6	5/16-18 x 11/16 FBHSCS	Economy
75-3422	40	6	M8 x 16mm BHSCS	Economy

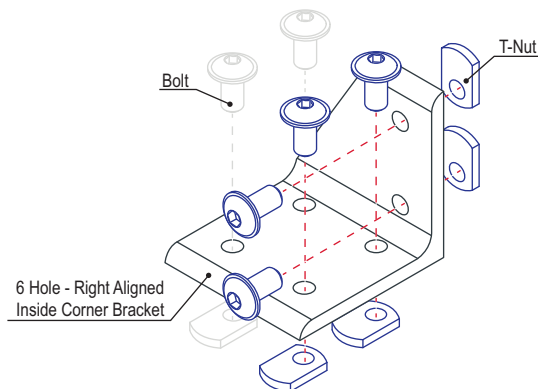



Part Description:

The 6 hole - wide slotted inside corner bracket is an external fastening method that creates a 90 degree connection. There are three adjacent holes on each side of the bracket. Three of the holes on one side are slotted, allowing for a larger degree in adjustability between connecting profiles. This bracket can provide infinite positioning along the profile T-slot, allowing a large degree of adjustability. It engages the 2-degree drop-lock feature when the assembly bolts are tightened to the required torque. It is a fastening method that can be repositioned and reused.

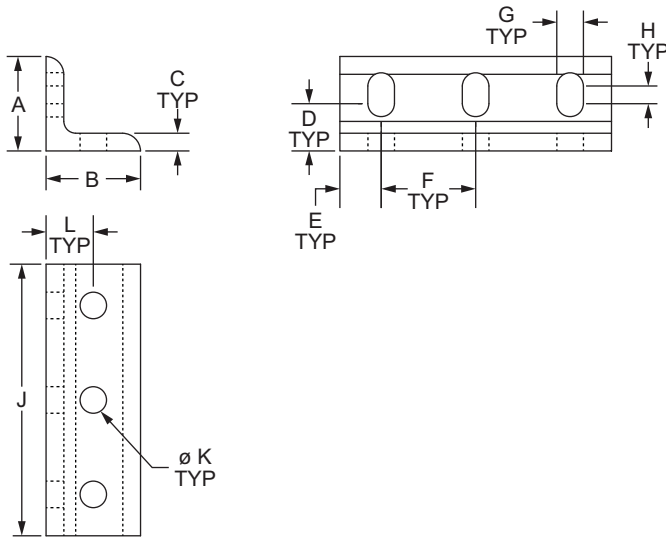

Part No.	Series	Material	Alloy*	Finish	A	B	C	D	E	F	G	H	J	K	L	Weight
4266	10	Aluminum	6105-T5	Clear Anodize	1.000"	1.000"	.188"	.500"	.438"	1.000"	.281"	.188"	2.875"	.281"	.500"	.081 lb
4266-Black	10			Black Anodize	1.000"	1.000"	.188"	.500"	.438"	1.000"	.281"	.188"	2.875"	.281"	.500"	.081 lb
4296	15			Clear Anodize	1.500"	1.500"	.250"	.500"	.656"	1.500"	.328"	.500"	4.312"	.328"	.750"	.257 lb
4296-Black	15			Black Anodize	1.500"	1.500"	.250"	.500"	.656"	1.500"	.328"	.500"	4.312"	.328"	.750"	.257 lb

* Or comparable

Suggested Hardware (Mount to T-Slot)

Part No.	Series	Qty.	Bolt	T-Nut
3393	10	6	1/4-20 x 1/2" BHSCS	Economy
3320	15	6	5/16-18 x 11/16" FBHSCS	Economy

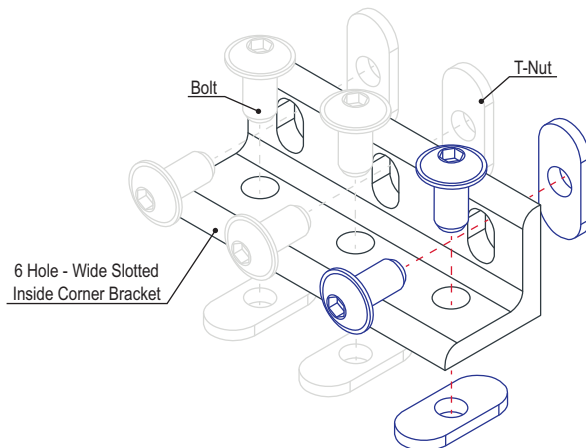

8 Hole - Inside Corner Bracket

Part Description:

The 8 hole - inside corner bracket is an external fastening method that creates a 90 degree connection and has four holes on each side of the bracket, comprised of two rows and two columns. It requires no machining services and can provide infinite positioning along the profile T-slot, allowing a large degree of adjustability. It is a fastening method that can be repositioned and reused.

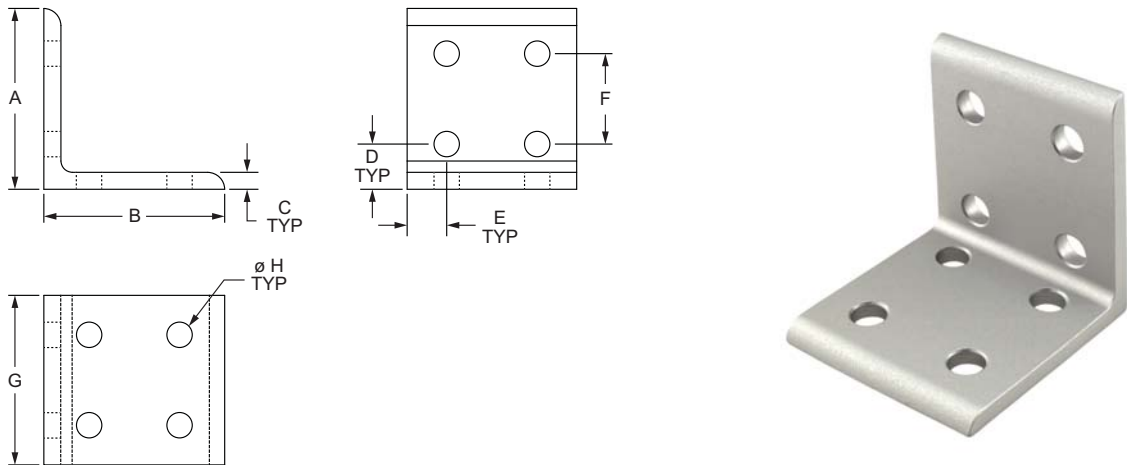

Part No.	Series	Material	Alloy*	Finish	A	B	C	D	E	F	G	H	Weight
4114	10	Aluminum	6105-T5	Clear Anodize	2.000"	2.000"	.188"	.500"	.438"	1.000"	1.875"	.281"	.115 lb
4114-Black	10			Black Anodize	2.000"	2.000"	.188"	.500"	.438"	1.000"	1.875"	.281"	.115 lb
4304	15			Clear Anodize	3.000"	3.000"	.250"	.750"	.656"	1.500"	2.810"	.328"	.365 lb
4304-Black	15			Black Anodize	3.000"	3.000"	.250"	.750"	.656"	1.500"	2.810"	.328"	.365 lb
25-4114	25			Clear Anodize	50.00mm	50.00mm	4.00mm	12.50mm	11.00mm	25.00mm	47.00mm	6.80mm	.0440 kg
25-4114-Black	25			Black Anodize	50.00mm	50.00mm	4.00mm	12.50mm	11.00mm	25.00mm	47.00mm	6.80mm	.0440 kg
40-4304	40			Clear Anodize	80.00mm	80.00mm	6.00mm	20.00mm	18.00mm	40.00mm	76.00mm	8.30mm	.1787 kg
40-4304-Black	40			Black Anodize	80.00mm	80.00mm	6.00mm	20.00mm	18.00mm	40.00mm	76.00mm	8.30mm	.1787 kg
NEW 45-4304	45			Clear Anodize	90.00mm	90.00mm	6.00mm	22.50mm	21.00mm	45.00mm	87.00mm	8.33mm	.2360 kg
NEW 45-4304-Black	45			Black Anodize	90.00mm	90.00mm	6.00mm	22.50mm	21.00mm	45.00mm	87.00mm	8.33mm	.2360 kg

* Or comparable

Suggested Hardware (Mount to T-Slot)

Part No.	Series	Qty.	Bolt	T-Nut
3393	10	8	1/4-20 x 1/2" BHSCS	Economy
3320	15	8	5/16-18 x 11/16 FBHSCS	Economy
75-3404	25	8	M6 x 10mm BHSCS	Economy
75-3422	40	8	M8 x 16mm BHSCS	Economy
75-3619	45	8	M8 x 18mm BHSCS	Drop-In

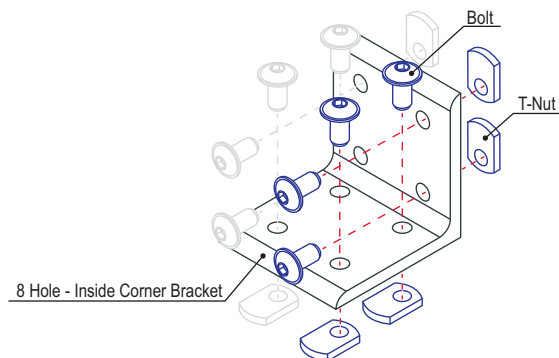

80/20[®] Inc. 8 Hole - 57mm Inside Corner Bracket with Dual Support

Part Description:

The 8 hole - 57mm inside corner bracket with dual support is an external, die-cast fastening method that creates a 90 degree connection. The dual support provides additional strength while the slotted holes allow for greater adjustability. Options with a slot tab help line up the profile with the bracket and prevent rotation. It requires no machining and can provide infinite positioning along the profile T-slot. **Additional Information:** Corner bracket covers are available separately and inhibit debris buildup while providing a finished look.

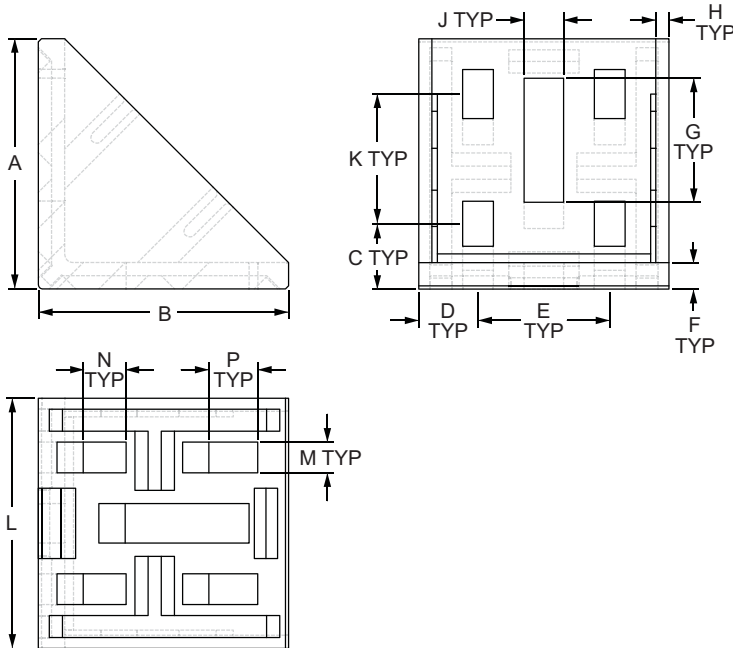

Part No.	Series	Material	Finish	A	B	C	D	E	F	G	H	J	K	L	M	N	P	Weight
14089	30	Zinc	Powder Coat	57.00mm	57.00mm	15.12mm	13.50mm	30.00mm	6.00mm	38.20mm	3.00mm	9.00mm	29.32mm	57.00mm	7.00mm	9.75mm	11.12mm	.2271 kg
14095	30	Aluminum	Natural	57.00mm	57.00mm	15.12mm	13.50mm	30.00mm	6.00mm	38.20mm	3.00mm	9.00mm	29.32mm	58.00mm	7.00mm	9.75mm	11.12mm	.1029 kg

Suggested Hardware (Mount to T-Slot)

Part No.	Series	Qty.	Bolt	T-Nut
75-3593	30	8	M6 x 14mm SHCS	Drop-In

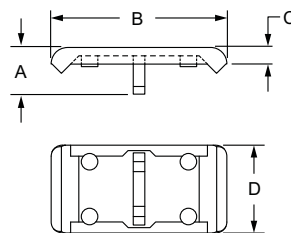

8 Hole - 57mm Inside Corner Bracket Cover Cap

Part No.	Bracket No.	Series	Material	A	B	C	D	Weight
12036	14089	30	PA6 GF 30	14.00mm	87.30mm	4.00mm	56.60mm	.0245 kg
12037	14095	30	PA6 GF 30	17.00mm	87.00mm	7.00mm	56.70mm	.0273 kg

8 Hole - 76mm Inside Corner Bracket with Dual Support

Part Description:

The 8 hole - 76mm inside corner bracket with dual support is an external, die-cast fastening method that creates a 90 degree connection. The dual support provides additional strength while the slotted holes allow for greater adjustability. Options with a slot tab help line up the profile with the bracket and prevent rotation. It requires no machining and can provide infinite positioning along the profile T-slot. **Additional Information:** Corner bracket covers are available separately and inhibit debris buildup while providing a finished look.

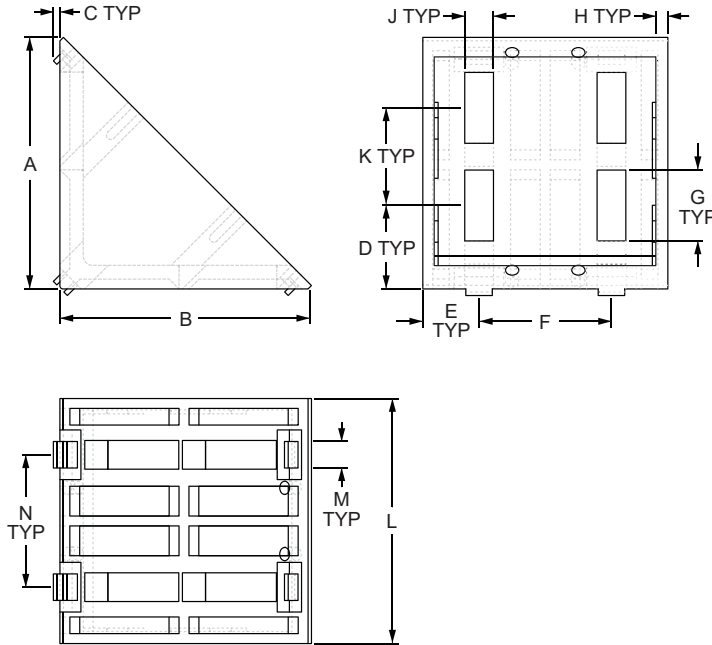

Part No.	Series	Material	Finish	A	B	C	D	E	F	G	H	J	K	L	M	N	Weight
14104	40	Zinc	Powder Coat	76.00mm	76.00mm	—	25.25mm	17.00mm	40.00mm	21.50mm	3.50mm	8.70mm	29.50mm	74.00mm	—	40.00mm	.4005 kg
14105	40			76.00mm	76.00mm	2.00mm	25.25mm	17.00mm	40.00mm	21.50mm	3.50mm	8.70mm	29.50mm	74.00mm	8.00mm	40.00mm	.4051 kg

Suggested Hardware (Mount to T-Slot)

Part No.	Series	Qty.	Bolt	T-Nut
75-3627	40	8	M8 x 18mm SHCS	Slide-In

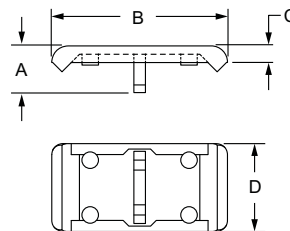

8 Hole - 76mm Inside Corner Bracket Cover Cap

Part No.	Series	Material	A	B	C	D	Weight
12039	40	PA6 GF 30	14.00mm	106.20mm	4.00mm	73.50mm	.0423 kg

80/20[®] Inc. 8 Hole - 86mm Inside Corner Bracket with Dual Support

Part Description:

The 8 hole - 86mm inside corner bracket with dual support is an external, die-cast fastening method that creates a 90 degree connection. The dual support provides additional strength while the slotted holes allow for greater adjustability. Options with a slot tab help line up the profile with the bracket and prevent rotation. It requires no machining and can provide infinite positioning along the profile T-slot. **Additional Information:** Corner bracket covers are available separately and inhibit debris buildup while providing a finished look.

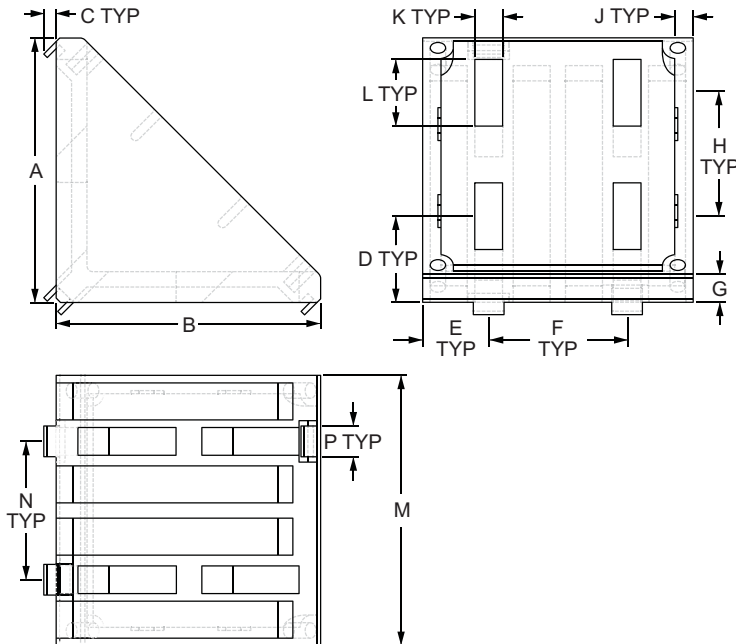

Part No.	Series	Material	Finish	A	B	C	D	E	F	G	H	J	K	L	M	N	P	Weight
14111	45	Aluminum	Natural	86.00mm	86.00mm	4.03mm	28.00mm	21.50mm	45.00mm	10.00mm	40.15mm	6.00mm	9.00mm	21.62mm	88.00mm	45.00mm	10.00mm	.3343 kg

Suggested Hardware (Mount to T-Slot)

Part No.	Series	Qty.	Bolt	T-Nut
75-3630	45	8	M8 x 20mm SHCS	Drop-In

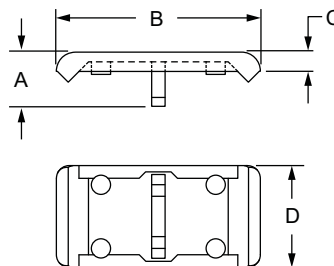

8 Hole - 86mm Inside Corner Bracket Cover Cap

Part No.	Series	Material	A	B	C	D	Weight
12040	45	PA6 GF 30	20.00mm	131.80mm	3.00mm	87.60mm	.0618 kg

9 Hole - Wide Slotted Inside Corner Bracket

Part Description:

The 9 hole - wide slotted inside corner bracket is an external fastening method that creates a 90 degree connection. One side of the bracket has three adjacent holes and the second side has six holes comprised of two rows and three columns. The three adjacent holes are slotted, allowing for a larger degree in adjustability between connecting profiles. This bracket requires no machining services and can provide infinite positioning along the profile T-slot. It engages the 2-degree drop-lock feature when the assembly bolts are tightened to the required torque.

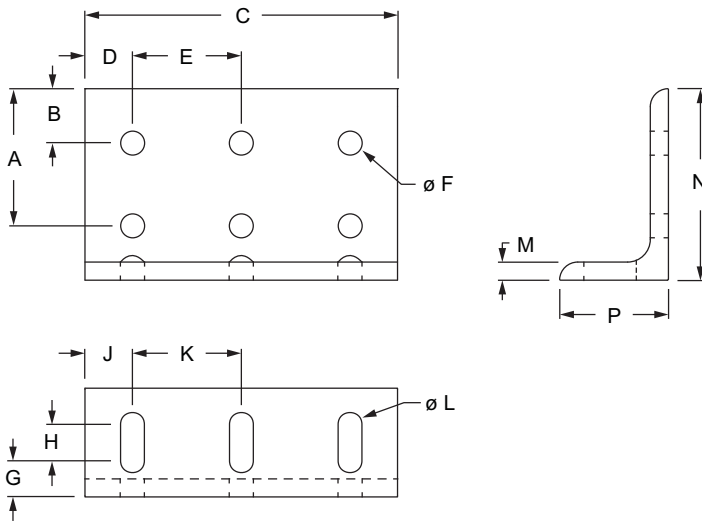

Part No.	Series	Color	A	B	C	D	E	F	G	H	J	K	L	M	N	P	Weight
4251	10	Clear	1.500"	.500"	2.875"	.437"	1.000"	.281"	.500"	.188"	.437"	1.000"	.281"	.188"	2.000"	1.000"	.129 lb
4251-Black	10	Black	1.500"	.500"	2.875"	.437"	1.000"	.281"	.500"	.188"	.437"	1.000"	.281"	.188"	2.000"	1.000"	.129 lb
4281	15	Clear	2.250"	.750"	4.310"	.656"	1.500"	.328"	.500"	.500"	.656"	1.500"	.328"	.250"	3.000"	1.500"	.406 lb
4281-Black	15	Black	2.250"	.750"	4.310"	.656"	1.500"	.328"	.500"	.500"	.656"	1.500"	.328"	.250"	3.000"	1.500"	.406 lb

Material Specifications

Material	Alloy*	Finish
Aluminum	6105-T5	Anodized

* Or comparable

Suggested Hardware (Mount to T-Slot)

Part No.	Series	Qty.	Bolt	T-Nut
3393	10	9	1/4-20 x 1/2" BHSCS	Economy
3320	15	9	5/16-18 x 11/16" FBHSCS	Economy

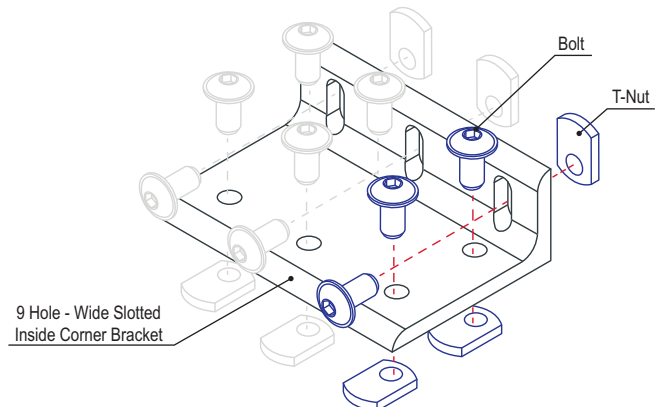



Part Description:

The 10 hole - inside corner bracket is an external fastening method that creates a 90 degree connection. One side of the bracket has six holes comprised of two rows and three columns, while the second side has four centered holes comprised of two rows and two columns. This bracket can be used to connect profiles that are within the same series but of different sizes. It requires no machining services and can provide infinite positioning along the profile T-slot, allowing a large degree of adjustability. The 10 hole - inside corner bracket engages the 2-degree drop-lock feature when the assembly bolts are tightened to the required torque. It is a fastening method that can be repositioned and reused.

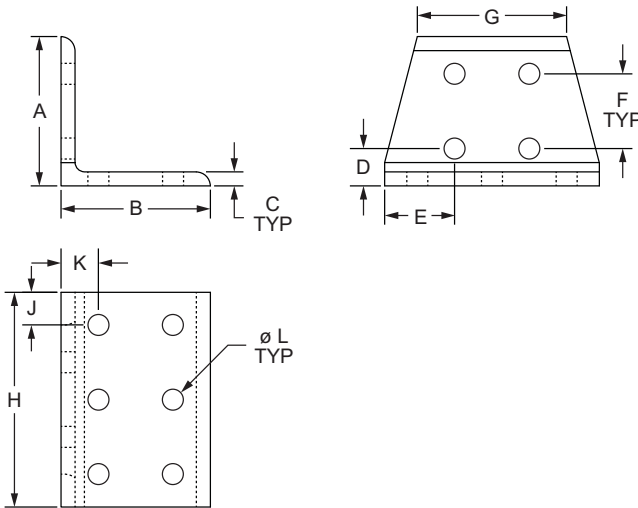

Part No.	Series	Material	Alloy*	Finish	A	B	C	D	E	F	G	H	J	K	L	Weight
4020	10	Aluminum	6105-T5	Clear Anodize	2.000"	2.000"	.188"	.500"	.937"	1.000"	2.000"	2.875"	.437"	.500"	.281"	.168 lb
4020-Black	10			Black Anodize	2.000"	2.000"	.188"	.500"	.937"	1.000"	2.000"	2.875"	.437"	.500"	.281"	.168 lb
4420	15			Clear Anodize	3.000"	3.000"	.250"	.750"	1.405"	1.500"	2.810"	4.310"	.654"	.750"	.328"	.522 lb
4420-Black	15			Black Anodize	3.000"	3.000"	.250"	.750"	1.405"	1.500"	2.810"	4.310"	.654"	.750"	.328"	.522 lb

* Or comparable

Suggested Hardware (Mount to T-Slot)

Part No.	Series	Qty.	Bolt	T-Nut
3393	10	10	1/4-20 x 1/2" BHSCS	Economy
3320	15	10	5/16-18 x 11/16 FBHSCS	Economy

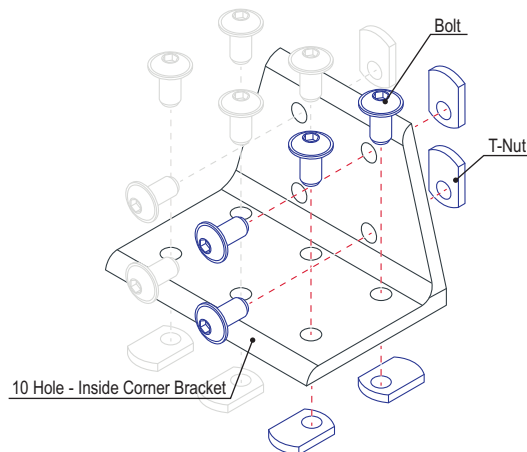

12 Hole - Tall Inside Corner Bracket

Part Description:

The 12 hole - tall inside corner bracket is an external fastening method that creates a 90 degree connection. Each side of the bracket has six holes comprised of three rows and two columns. This fastener requires no machining services and can provide infinite positioning along the profile T-slot, allowing a large degree of adjustability. The 12 hole - tall inside corner bracket engages the 2-degree drop-lock feature when the assembly bolts are tightened to the required torque. It is a fastening method that can be repositioned and reused.

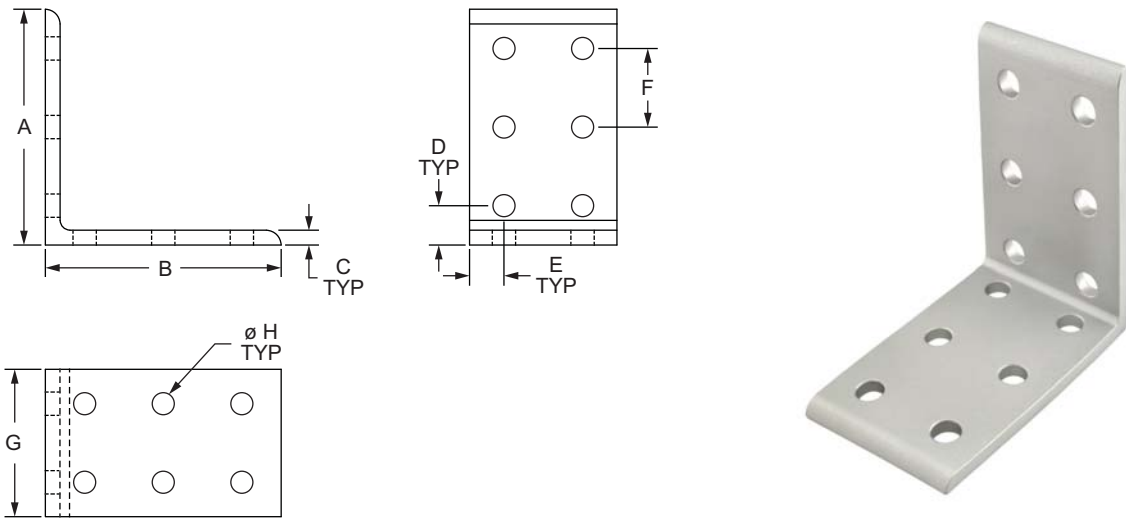

Part No.	Series	Material	Alloy*	Finish	A	B	C	D	E	F	G	H	Weight
4014	10	Aluminum	6105-T5	Clear Anodize	3.000"	3.000"	.188"	.500"	.438"	1.000"	1.875"	.281"	.177 lb
4014-Black	10			Black Anodize	3.000"	3.000"	.188"	.500"	.438"	1.000"	1.875"	.281"	.177 lb
4414	15			Clear Anodize	4.500"	4.500"	.250"	.750"	.656"	1.500"	2.812"	.328"	.560 lb
4414-Black	15			Black Anodize	4.500"	4.500"	.250"	.750"	.656"	1.500"	2.812"	.328"	.560 lb

* Or comparable

Suggested Hardware (Mount to T-Slot)

Part No.	Series	Qty.	Bolt	T-Nut
3393	10	12	1/4-20 x 1/2" BHSCS	Economy
3320	15	12	5/16-18 x 11/16 FBHSCS	Economy

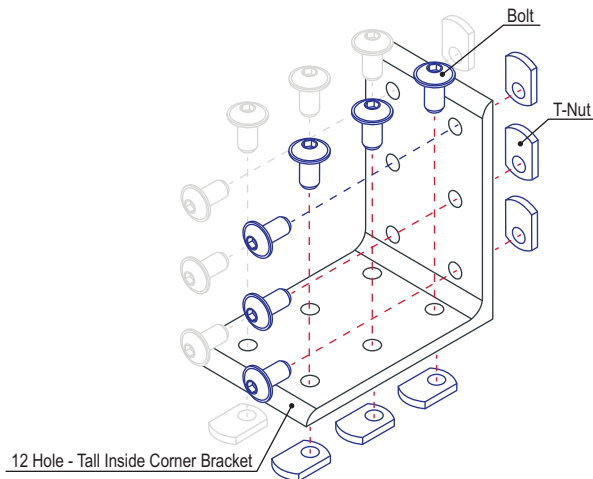

FASTENERS



Part Description:

The 12 hole - wide inside corner bracket is an external fastening method that creates a 90 degree connection. Each side of the bracket has six holes comprised of two rows and three columns. This fastener requires no machining services and can provide infinite positioning along the profile T-slot, allowing a large degree of adjustability. The 12 hole - wide inside corner bracket engages the 2-degree drop-lock feature when the assembly bolts are tightened to the required torque. It is a fastening method that can be repositioned and reused.

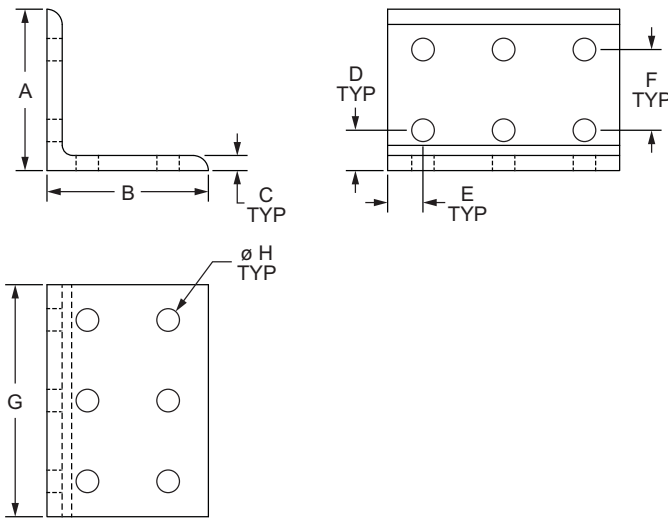

Part No.	Series	Material	Alloy*	Finish	A	B	C	D	E	F	G	H	Weight
4016	10	Aluminum	6105-T5	Clear Anodize	2.000"	2.000"	.188"	.500"	.438"	1.000"	2.875"	.281"	.178 lb
4016-Black	10			Black Anodize	2.000"	2.000"	.188"	.500"	.438"	1.000"	2.875"	.281"	.178 lb
4416	15			Clear Anodize	3.000"	3.000"	.250"	.750"	.656"	1.500"	4.310"	.328"	.564 lb
4416-Black	15			Black Anodize	3.000"	3.000"	.250"	.750"	.656"	1.500"	4.310"	.328"	.564 lb

* Or comparable

Suggested Hardware (Mount to T-Slot)

Part No.	Series	Qty.	Bolt	T-Nut
3393	10	12	1/4-20 x 1/2" BHSCS	Economy
3320	15	12	5/16-18 x 11/16 FBHSCS	Economy

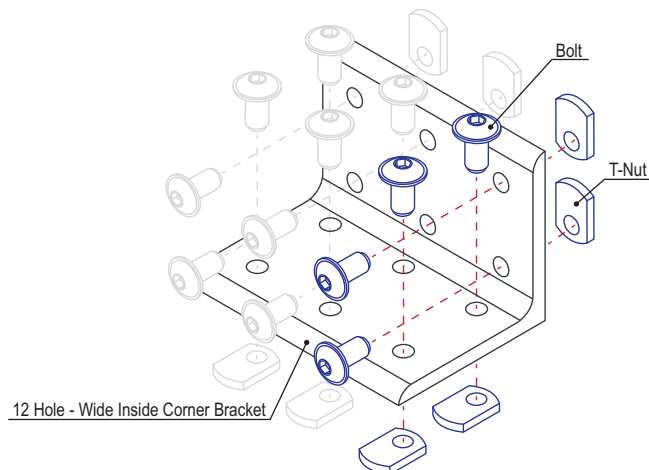

18 Hole - Inside Corner Bracket

Part Description:

The 18 hole - inside corner bracket is an external fastening method that creates a 90 degree connection. Each side of the bracket has nine holes comprised of three rows and three columns. This fastener requires no machining services and can provide infinite positioning along the profile T-slot, allowing a large degree of adjustability. The 18 hole - inside corner bracket engages the 2-degree drop-lock feature when the assembly bolts are tightened to the required torque. It is a fastening method that can be repositioned and reused.

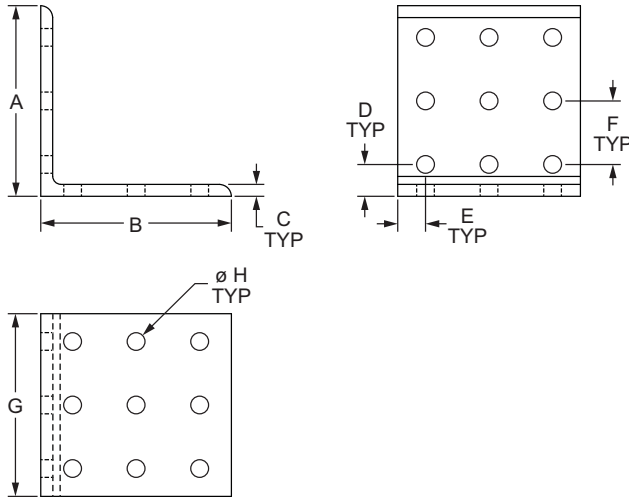

Part No.	Series	Material	Alloy*	Finish	A	B	C	D	E	F	G	H	Weight
4017	10	Aluminum	6105-T5	Clear Anodize	3.000"	3.000"	.188"	.500"	.438"	1.000"	2.875"	.281"	.271 lb
4017-Black	10			Black Anodize	3.000"	3.000"	.188"	.500"	.438"	1.000"	2.875"	.281"	.271 lb
4417	15			Clear Anodize	4.500"	4.500"	.250"	.750"	.656"	1.500"	4.310"	.328"	.861 lb
4417-Black	15			Black Anodize	4.500"	4.500"	.250"	.750"	.656"	1.500"	4.310"	.328"	.861 lb

* Or comparable

Suggested Hardware (Mount to T-Slot)

Part No.	Series	Qty.	Bolt	T-Nut
3393	10	18	1/4-20 x 1/2" BHSCS	Economy
3320	15	18	5/16-18 x 11/16 FBHSCS	Economy

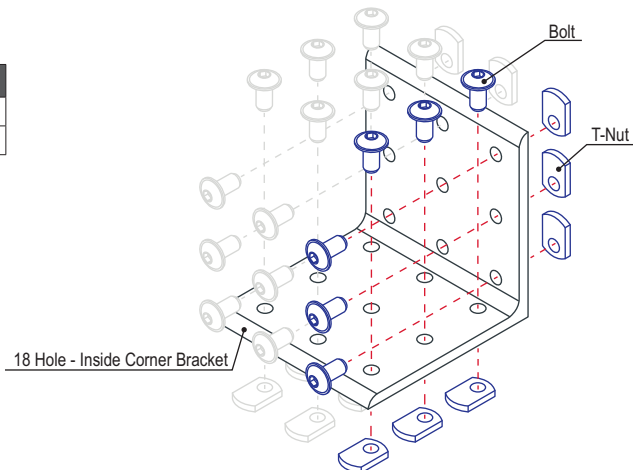

Part Description:

The 3 way - triangular corner bracket is a die-cast external fastening method that is typically used to create a corner connection between three profiles. It is a connection method that is recessed within the corner and offers stability. The simplicity of this bracket makes it easy to connect multiple profiles. The 3 way - triangular corner bracket requires an end tap machining service (see page 853) on each of the connecting profiles. For triangular corner bracket cover caps see page 789.

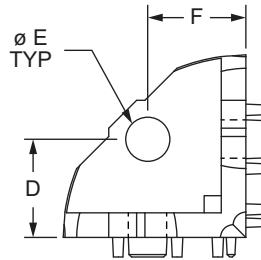
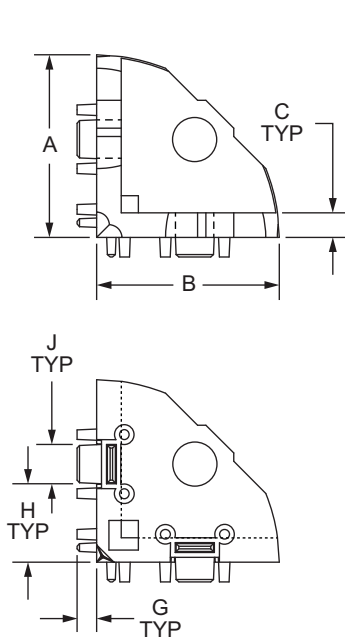

Part No.	Series	Material	Finish	A	B	C	D	E	F	G	H	J	Weight
14113	15	Zinc	Natural	1.465"	1.465"	.197"	.787"	.354"	.787"	.157"	.630"	.315"	.148 lb
14114	40			37.20mm	37.20mm	5.00mm	20.00mm	9.00mm	20.00mm	4.00mm	16.00mm	8.00mm	.0763 kg

Required Machining Services

Machining Type	Machined	Reference Page
Tap Profile End	Mounting Profiles	853

Suggested Hardware (Mount to Profile End)

Part No.	Series	Qty.	Bolt
3114	15	3	5/16-18 x 3/4 BHSCS
11-8320	40	3	M8 x 20mm BHSCS

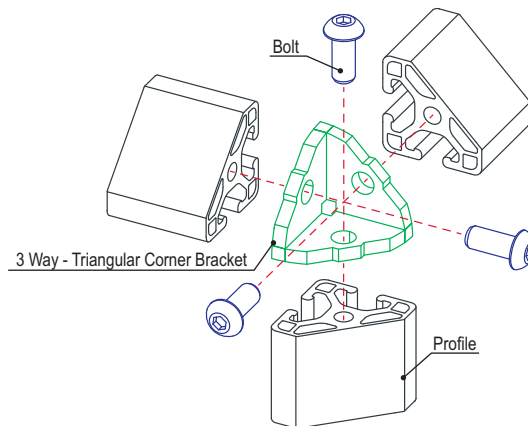

3 Way - Rounded Corner Bracket

Part Description:

The 3 way - rounded corner bracket is a die-cast external fastening method that is typically used to create an outside corner connection between three profiles. It offers stability and can also be reused and repositioned. The simplicity of this bracket makes it easy to connect multiple profiles. The 3 way - rounded corner bracket requires an end tap machining service (see page 853) on each of the connecting profiles. For rounded corner bracket cover caps see page 789.

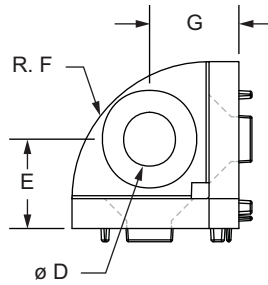
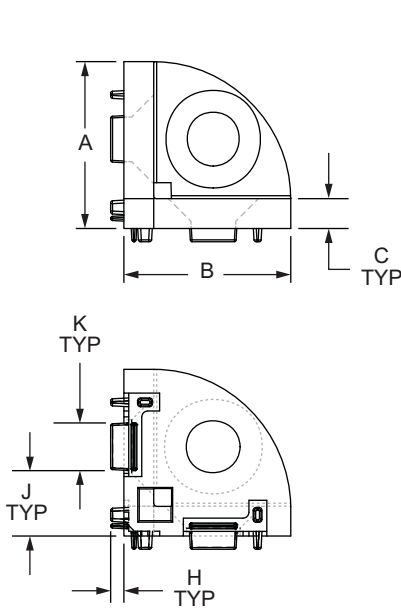

Part No.	Series	Material	Finish	A	B	C	D	E	F	G	H	J	K	Weight
14112	30	Zinc	Natural	28.00mm	28.00mm	5.00mm	9.00mm	15.00mm	23.00mm	15.00mm	2.20mm	11.00mm	8.00mm	.0367 kg

Required Machining Services

Machining Type	Machined	Reference Page
Tap Profile End	Mounting Profiles	853

Suggested Hardware (Mount to Profile End)

Part No.	Series	Qty.	Bolt
11-8716	30	3	M8 x 16mm Black Zinc FHSCS

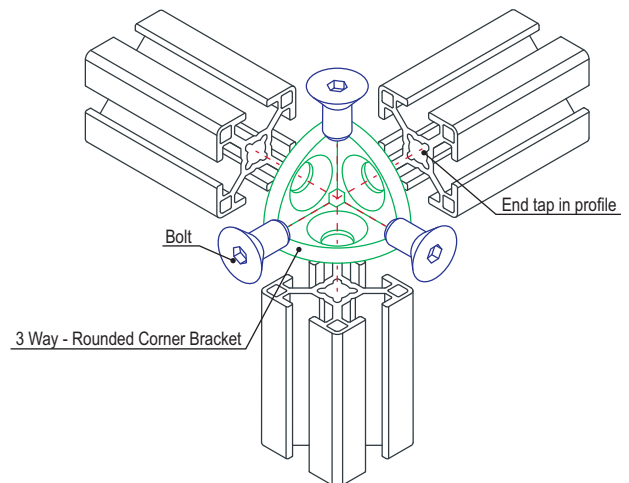

80/20[®] Inc. 2 Hole - Lite Transition Inside Corner Bracket

Part Description:

The 2 hole - lite transition inside corner bracket creates a 90 degree connection between profiles within the same product type (either fractional or metric) but of differing series. It is a lightweight external fastening method that requires no machining services. The bracket is flush with the profiles, taking up less space in the overall design. This option can provide infinite positioning along the profile T-slot, allowing for a large degree of adjustability as well as being reconfigurable and reusable.

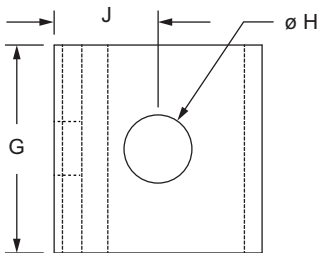
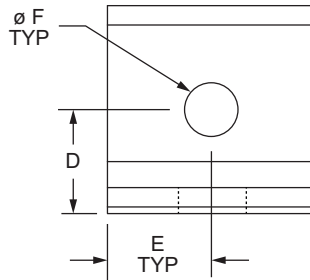
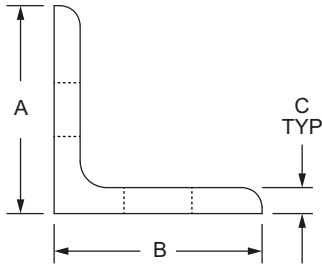

Part No.	Series	Material	Alloy*	Finish	A	B	C	D	E	F	G	H	J	Weight
4509	10 to 15	Aluminum	6105-T5	Clear Anodize	1.000"	1.000"	.125"	.500"	.500"	.257"	1.000"	.328"	.500"	.020 lb
4509-Black	10 to 15			Black Anodize	1.000"	1.000"	.125"	.500"	.500"	.257"	1.000"	.328"	.500"	.020 lb
65-4509	25 to 40			Clear Anodize	25.00mm	25.00mm	3.00mm	12.50mm	12.50mm	6.30mm	25.00mm	8.30mm	12.50mm	.0086 kg
65-4509-Black	25 to 40			Black Anodize	25.00mm	25.00mm	3.00mm	12.50mm	12.50mm	6.30mm	25.00mm	8.30mm	12.50mm	.0086 kg

* Or comparable

Suggested Hardware (Mount to T-Slot)

Part No.	Series	Qty.	Bolt	T-Nut
3386	10 to 15	1	1/4-20 x 3/8" FBHSCS	Economy
3319		1	5/16-18 x 1/2" FBHSCS	Economy
75-3404	25 to 40	1	M6 x 10mm BHSCS	Economy
75-3421		1	M8 x 12mm BHSCS	Economy

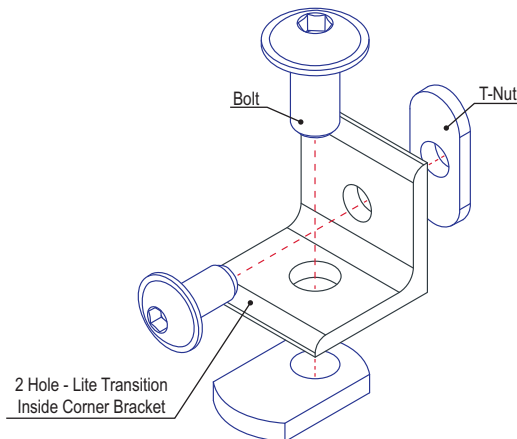

2 Hole - Transition Inside Corner Bracket



Part Description:

The 2 hole - transition inside corner bracket creates a 90 degree connection between profiles within the same product type (either fractional or metric) but of differing series. It is an external fastening method that requires no machining services. The bracket is flush with the profiles, taking up less space in the overall design. This option can provide infinite positioning along the profile T-slot, allowing for a large degree of adjustability as well as being reconfigurable and reusable.

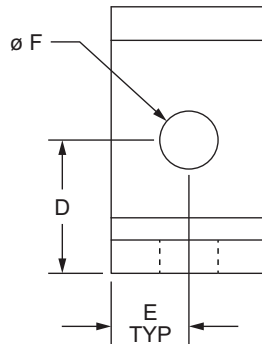
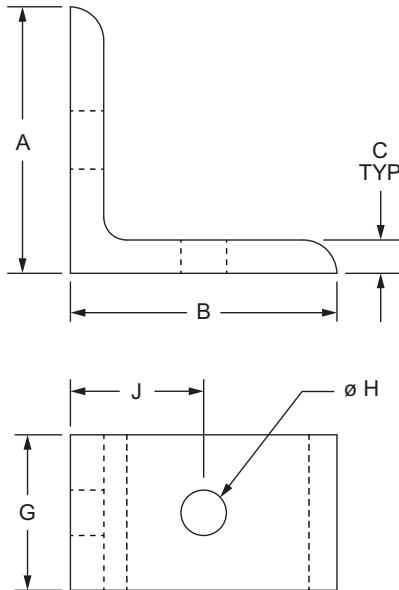

Part No.	Series	Material	Alloy*	Finish	A	B	C	D	E	F	G	H	J	Weight
4503	10 to 15	Aluminum	6105-T5	Clear Anodize	1.500"	1.500"	.188"	.750"	.438"	.328"	.875"	.257"	.750"	.041 lb
4503-Black	10 to 15			Black Anodize	1.500"	1.500"	.188"	.750"	.438"	.328"	.875"	.257"	.750"	.041 lb
65-4503	25 to 40			Clear Anodize	40.00mm	40.00mm	6.00mm	20.00mm	11.00mm	8.33mm	22.00mm	6.30mm	20.00mm	.0248 kg
65-4503-Black	25 to 40			Black Anodize	40.00mm	40.00mm	6.00mm	20.00mm	11.00mm	8.33mm	22.00mm	6.30mm	20.00mm	.0248 kg

* Or comparable

Suggested Hardware (Mount to T-Slot)

Part No.	Series	Qty.	Bolt	T-Nut
3393	10 to 15	1	1/4-20 x 1/2" BHSCS	Economy
3435		1	5/16-18 x 5/8 BHSCS, Washer	Economy
75-3405	25 to 40	1	M6 x 12mm BHSCS	Economy
75-3422		1	M8 x 16mm BHSCS	Economy

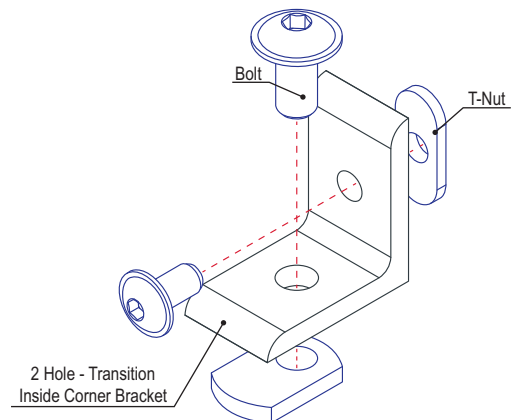



80/20[®] Inc.

4 Hole - Tall Transition Inside Corner Bracket

Part Description:

The 4 hole - tall transition inside corner bracket creates a 90 degree connection between profiles within the same product type (either fractional or metric) but of differing series. Each side of the bracket has two holes stacked one on top of the other. It is an external fastening method that requires no machining services. The bracket is flush with the profiles, taking up less space in the overall design. This option can provide infinite positioning along the profile T-slot, allowing for a large degree of adjustability as well as being reconfigurable and reusable.

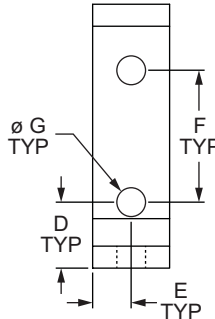
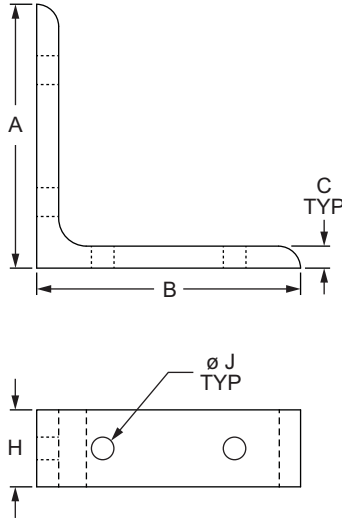

Part No.	Series	Material	Alloy*	Finish	A	B	C	D	E	F	G	H	J	Weight
4504	10 to 15	Aluminum	6105-T5	Clear Anodize	3.000"	3.000"	.250"	.750"	.438"	1.500"	.328"	.875"	.257"	.113 lb
4504-Black	10 to 15			Black Anodize	3.000"	3.000"	.250"	.750"	.438"	1.500"	.328"	.875"	.257"	.113 lb
65-4504	25 to 40			Clear Anodize	80.00mm	80.00mm	6.00mm	20.00mm	11.00mm	40.00mm	8.30mm	22.00mm	6.30mm	.0513 kg
65-4504-Black	25 to 40			Black Anodize	80.00mm	80.00mm	6.00mm	20.00mm	11.00mm	40.00mm	8.30mm	22.00mm	6.30mm	.0513 kg

* Or comparable

Suggested Hardware (Mount to T-Slot)

Part No.	Series	Qty.	Bolt	T-Nut
3393	10 to 15	2	1/4-20 x 1/2" BHSCS	Economy
3320		2	5/16-18 x 11/16" FBHSCS	Economy
75-3405	25 to 40	2	M6 x 12mm BHSCS	Economy
75-3422		2	M8 x 16mm BHSCS	Economy

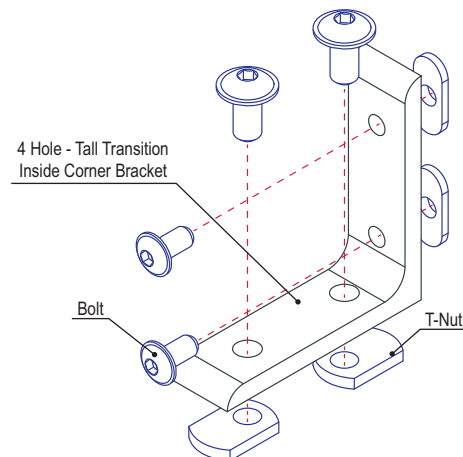

4 Hole - Lite Wide Transition Inside Corner Bracket

Part Description:

The 4 hole - lite wide transition inside corner bracket creates a 90 degree connection between profiles within the same product type (either fractional or metric) but of differing series. It is a lightweight bracket with two adjacent holes on each side. It is an external fastening method that requires no machining services. The bracket is flush with the profiles, taking up less space in the overall design. This option can provide infinite positioning along the profile T-slot, allowing for a large degree of adjustability as well as being reconfigurable and reusable.

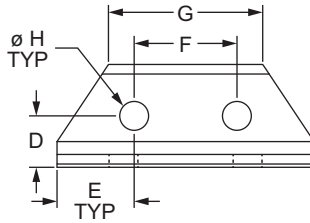
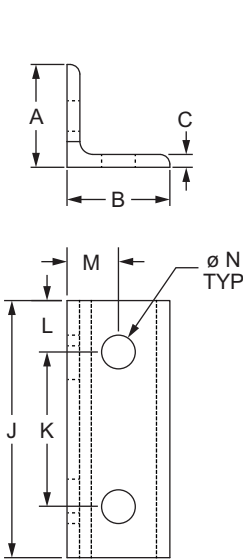

Part No.	Series	Color	A	B	C	D	E	F	G	H	J	K	L	M	N	Weight
4511	10 to 15	Clear	1.000"	1.000"	.125"	.500"	.750"	1.000"	1.500"	.281"	2.500"	1.500"	.500"	.500"	.328"	.048 lb
4511-Black	10 to 15	Black	1.000"	1.000"	.125"	.500"	.750"	1.000"	1.500"	.281"	2.500"	1.500"	.500"	.500"	.328"	.048 lb

Material Specifications

Material	Alloy*	Finish
Aluminum	6105-T5	Anodize

* Or comparable

Suggested Hardware (Mount to T-Slot)

Part No.	Series	Qty.	Bolt	T-Nut
3386	10 to 15	2	1/4-20 x 3/8" FBHSCS	Economy
3319		2	5/16-18 x 1/2" FBHSCS	Economy

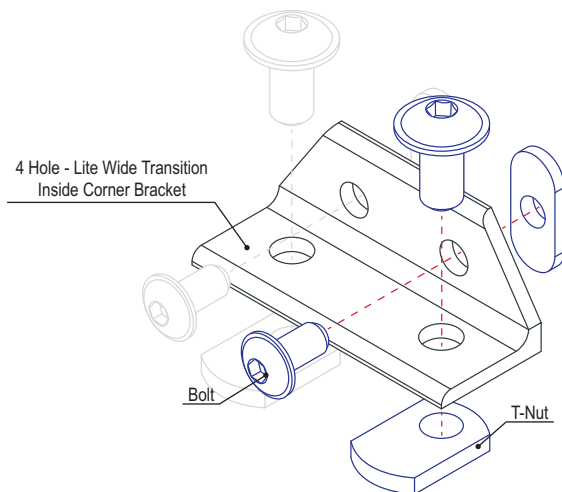



80/20[®] Inc. 4 Hole - Wide Transition Inside Corner Bracket

Part Description:

The 4 hole - wide transition inside corner bracket creates a 90 degree connection between profiles within the same product type (either fractional or metric) but of differing series. It has two adjacent holes on each side and is an external fastening method that requires no machining services. The bracket is flush with the profiles, taking up less space in the overall design. This option can provide infinite positioning along the profile T-slot, allowing for a large degree of adjustability as well as being reconfigurable and reusable.

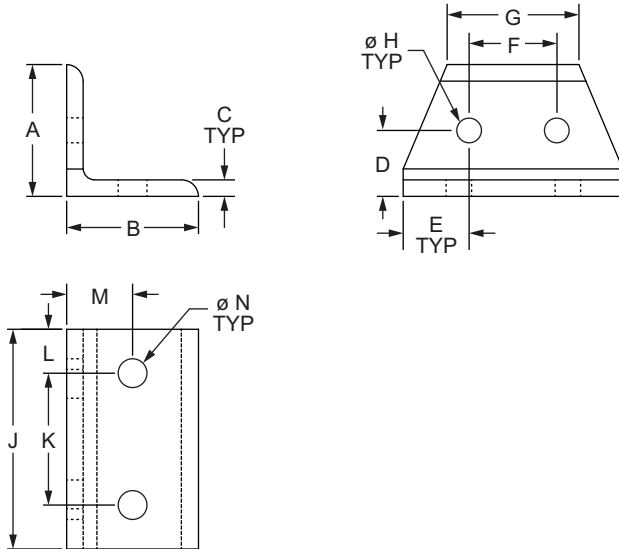

Part No.	Series	Color	A	B	C	D	E	F	G	H	J	K	L	M	N	Weight
4512	10 to 15	Clear	1.500"	1.500"	.188"	.750"	.750"	1.000"	1.500"	.281"	2.500"	1.500"	.500"	.750"	.328"	.108 lb
4512-Black	10 to 15	Black	1.500"	1.500"	.188"	.750"	.750"	1.000"	1.500"	.281"	2.500"	1.500"	.500"	.750"	.328"	.108 lb
65-4512	25 to 40	Clear	40.00mm	40.00mm	6.00mm	20.00mm	18.75mm	25.00mm	40.00mm	6.30mm	62.50mm	40.00mm	11.25mm	20.00mm	8.30mm	.0671 kg
65-4512-Black	25 to 40	Black	40.00mm	40.00mm	6.00mm	20.00mm	18.75mm	25.00mm	40.00mm	6.30mm	62.50mm	40.00mm	11.25mm	20.00mm	8.30mm	.0671 kg

Material Specifications

Material	Alloy*	Finish
Aluminum	6105-T5	Anodize

* Or comparable

Suggested Hardware (Mount to T-Slot)

Part No.	Series	Qty.	Bolt	T-Nut
3393		2	1/4-20 x 1/2" BHSCS	Economy
3320	10 to 15	2	5/16-18 x 11/16" FBHSCS	Economy
75-3405		2	M6 x 12mm BHSCS	Economy
75-3422	25 to 40	2	M8 x 16mm BHSCS	Economy

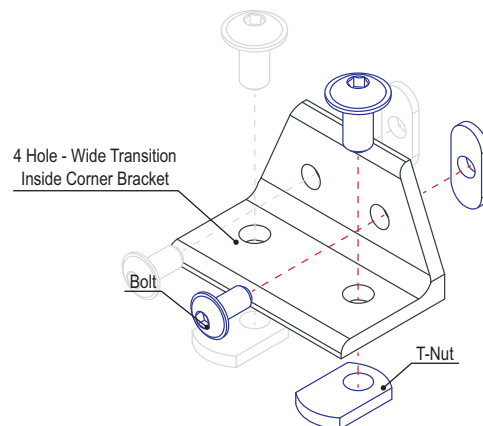

8 Hole - Center Transition Inside Corner Bracket

Part Description:

The 8 hole - center transition inside corner bracket creates a 90 degree connection between profiles within the same product type (either fractional or metric) but of differing series. It has four holes, comprised of two rows and two columns, on each side and it is an external fastening method that requires no machining services. The bracket is flush with the profiles, taking up less space in the overall design. This option can provide infinite positioning along the profile T-slot, allowing for a large degree of adjustability as well as being reconfigurable and reusable.

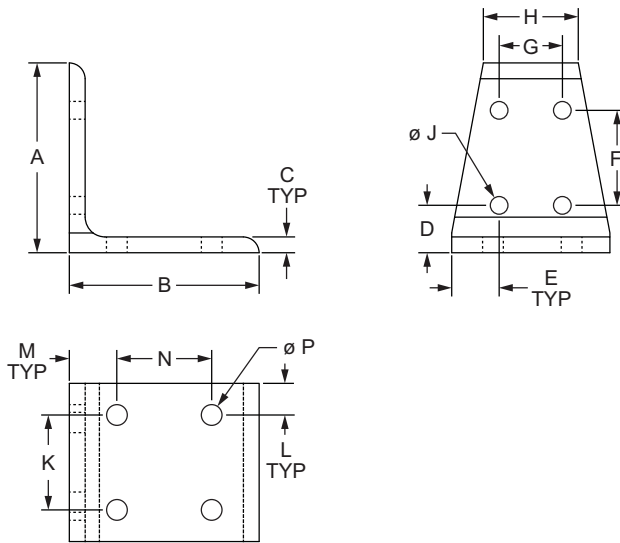

Part No.	Series	Color	A	B	C	D	E	F	G	H	J	K	L	M	N	P	Weight
4513	10 to 15	Clear	3.000"	3.000"	.250"	.750"	.750"	1.500"	1.000"	1.500"	.281"	1.500"	.500"	.750"	1.500"	.328"	.305 lb
4513-Black	10 to 15	Black	3.000"	3.000"	.250"	.750"	.750"	1.500"	1.000"	1.500"	.281"	1.500"	.500"	.750"	1.500"	.328"	.305 lb
65-4513	25 to 40	Clear	80.00mm	80.00mm	6.00mm	20.00mm	18.75mm	40.00mm	25.00mm	40.00mm	6.30mm	40.00mm	11.25mm	20.00mm	40.00mm	8.30mm	.1370 kg
65-4513-Black	25 to 40	Black	80.00mm	80.00mm	6.00mm	20.00mm	18.75mm	40.00mm	25.00mm	40.00mm	6.30mm	40.00mm	11.25mm	20.00mm	40.00mm	8.30mm	.1370 kg

Material Specifications

Material	Alloy*	Finish
Aluminum	6105-T5	Anodize

* Or comparable

Suggested Hardware (Mount to T-Slot)

Part No.	Series	Qty.	Bolt	T-Nut
3393	10 to 15	4	1/4-20 x 1/2" BHSCS	Economy
3320		4	5/16-18 x 11/16" FBHSCS	Economy
75-3405	25 to 40	4	M6 x 12mm BHSCS	Economy
75-3422		4	M8 x 16mm BHSCS	Economy

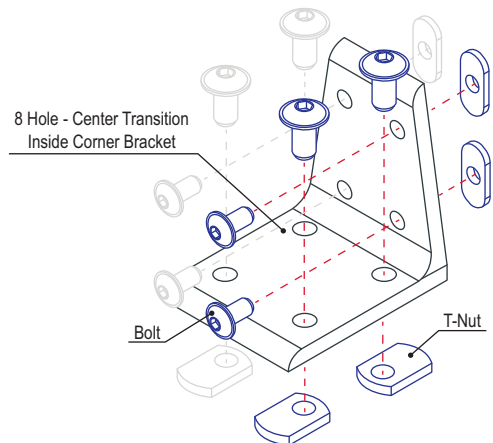

Part Description:

The 2 hole - gusseted inside corner bracket is a strong, external fastening method that creates a 90 degree connection. It requires no machining services and can provide infinite positioning along the profile T-slot, allowing a large degree of adjustability. The shape of the gusset provides extra material, strengthening the connection. It is a fastening method that can be repositioned and reused.

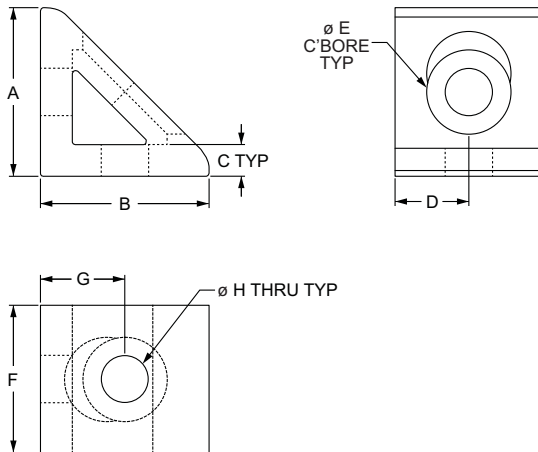

Part No.	Series	Material	Alloy*	Finish	A	B	C	D	E	F	G	H	Weight
4132	10	Aluminum	6105-T5	Clear Anodize	1.000"	1.000"	.188"	.438"	.500"	.875"	.500"	.281"	.035 lb
4132-Black	10			Black Anodize	1.000"	1.000"	.188"	.438"	.500"	.875"	.500"	.281"	.035 lb
4332	15			Clear Anodize	1.500"	1.500"	.250"	.656"	.750"	1.312"	.750"	.328"	.111 lb
4332-Black	15			Black Anodize	1.500"	1.500"	.250"	.656"	.750"	1.312"	.750"	.328"	.111 lb
25-4132	25			Clear Anodize	25.00mm	25.00mm	4.00mm	11.00mm	12.70mm	22.00mm	12.50mm	6.80mm	.0140 kg
25-4132-Black	25			Black Anodize	25.00mm	25.00mm	4.00mm	11.00mm	12.70mm	22.00mm	12.50mm	6.80mm	.0140 kg
NEW 30-4332	30			Clear Anodize	30.00mm	30.00mm	4.00mm	13.50mm	12.70mm	27.00mm	15.00mm	6.81mm	.0228 kg
NEW 30-4332-Black	30			Black Anodize	30.00mm	30.00mm	4.00mm	13.50mm	12.70mm	27.00mm	15.00mm	6.81mm	.0228 kg
40-4332	40			Clear Anodize	40.00mm	40.00mm	6.00mm	18.00mm	20.00mm	36.00mm	20.00mm	8.30mm	.0567 kg
40-4332-Black	40			Black Anodize	40.00mm	40.00mm	6.00mm	18.00mm	20.00mm	36.00mm	20.00mm	8.30mm	.0567 kg
NEW 45-4332	45			Clear Anodize	45.00mm	45.00mm	6.00mm	21.00mm	20.00mm	42.00mm	22.50mm	8.33mm	.0802 kg
NEW 45-4332-Black	45			Black Anodize	45.00mm	45.00mm	6.00mm	21.00mm	20.00mm	42.00mm	22.50mm	8.33mm	.0802 kg

* Or comparable

Suggested Hardware (Mount to T-Slot)

Part No.	Series	Qty.	Bolt	T-Nut
3393	10	2	1/4-20 x 1/2" BHSCS	Economy
3320	15	2	5/16-18 x 11/16" FBHSCS	Economy
75-3404	25	2	M6 x 10mm BHSCS	Economy
75-3600	30	2	M6 x 12mm BHSCS	Drop-In
75-3422	40	2	M8 x 16mm BHSCS	Economy
75-3619	45	2	M8 x 18mm BHSCS	Drop-In

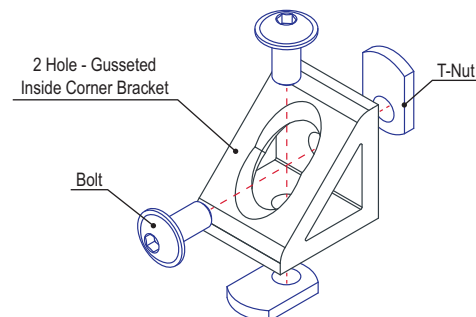

4 Hole - Tall Gusseted Inside Corner Bracket

Part Description:

The 4 hole - tall gusseted inside corner bracket is a strong, external fastening method that creates a 90 degree connection. Each side of the bracket has two holes stacked one on top of the other. It requires no machining services and can provide infinite positioning along the profile T-slot, allowing a large degree of adjustability. The shape of the gusset provides extra material, strengthening the connection. It is a fastening method that can be repositioned and reused.

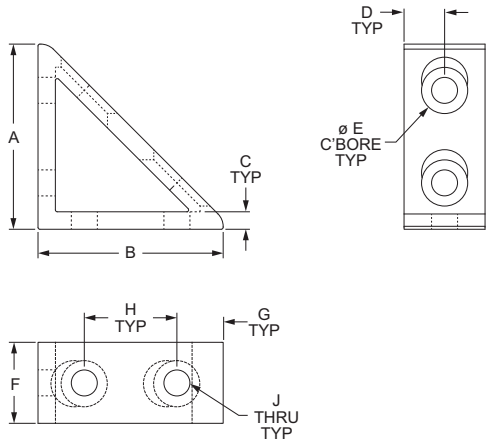

Part No.	Series	Material	Alloy*	Finish	A	B	C	D	E	F	G	H	J	Weight	
4136	10	Aluminum	6105-T5	Clear Anodize	2.000"	2.000"	.188"	.438"	.500"	.875"	.500"	1.000"	.281"	.078 lb	
4136-Black	10			Black Anodize	2.000"	2.000"	.188"	.438"	.500"	.875"	.500"	1.000"	.281"	.078 lb	
4336	15			Clear Anodize	3.000"	3.000"	.250"	.656"	.750"	1.312"	.750"	1.500"	.328"	.243 lb	
4336-Black	15			Black Anodize	3.000"	3.000"	.250"	.656"	.750"	1.312"	.750"	1.500"	.328"	.243 lb	
25-4136	25			Clear Anodize	50.00mm	50.00mm	4.00mm	11.00mm	12.70mm	22.00mm	12.50mm	25.00mm	6.80mm	6.80mm	.0354 kg
25-4136-Black	25			Black Anodize	50.00mm	50.00mm	4.00mm	11.00mm	12.70mm	22.00mm	12.50mm	25.00mm	6.80mm	6.80mm	.0354 kg
NEW 30-4336	30			Clear Anodize	60.00mm	60.00mm	4.00mm	13.50mm	12.70mm	27.00mm	15.00mm	30.00mm	6.81mm	6.81mm	.0496 kg
NEW 30-4336-Black	30			Black Anodize	60.00mm	60.00mm	4.00mm	13.50mm	12.70mm	27.00mm	15.00mm	30.00mm	6.81mm	6.81mm	.0496 kg
40-4336	40			Clear Anodize	80.00mm	80.00mm	6.00mm	18.00mm	20.00mm	36.00mm	20.00mm	40.00mm	8.30mm	8.30mm	.1234 kg
40-4336-Black	40			Black Anodize	80.00mm	80.00mm	6.00mm	18.00mm	20.00mm	36.00mm	20.00mm	40.00mm	8.30mm	8.30mm	.1234 kg
NEW 45-4336	45			Clear Anodize	90.00mm	90.00mm	6.00mm	21.00mm	20.00mm	42.00mm	22.50mm	45.00mm	8.33mm	8.33mm	.1747 kg
NEW 45-4336-Black	45			Black Anodize	90.00mm	90.00mm	6.00mm	21.00mm	20.00mm	42.00mm	22.50mm	45.00mm	8.33mm	8.33mm	.1747 kg

* Or comparable

Suggested Hardware (Mount to T-Slot)

Part No.	Series	Qty.	Bolt	T-Nut
3393	10	4	1/4-20 x 1/2" BHSCS	Economy
3320	15	4	5/16-18 x 11/16" FBHSCS	Economy
75-3404	25	4	M6 x 10mm BHSCS	Economy
75-3600	30	4	M6 x 12mm BHSCS	Drop-In
75-3422	40	4	M8 x 16mm BHSCS	Economy
75-3619	45	4	M8 x 18mm BHSCS	Drop-In

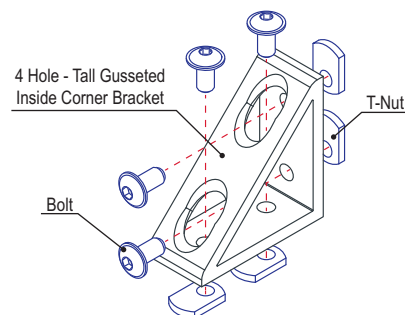



80/20[®] Inc. 4 Hole - Wide Gusseted Inside Corner Bracket

Part Description:

The 4 hole - wide gusseted inside corner bracket is a strong, external fastening method that creates a 90 degree connection. There are two adjacent holes on each side of the bracket. It requires no machining services and can provide infinite positioning along the profile T-slot, allowing a large degree of adjustability. The shape of the gusset provides extra material, strengthening the connection. It is a fastening method that can be repositioned and reused.

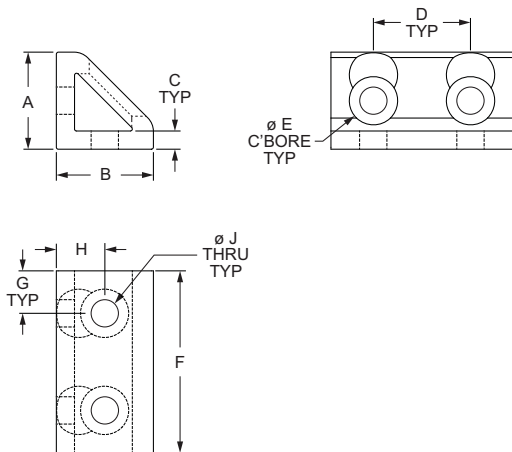

FASTENERS

Part No.	Series	Material	Alloy*	Finish	A	B	C	D	E	F	G	H	J	Weight
4134	10	Aluminum	6105-T5	Clear Anodize	1.000"	1.000"	.188"	1.000"	.500"	1.875"	.438"	.500"	.281"	.077 lb
4134-Black	10			Black Anodize	1.000"	1.000"	.188"	1.000"	.500"	1.875"	.438"	.500"	.281"	.077 lb
4334	15			Clear Anodize	1.500"	1.500"	.250"	1.500"	.750"	2.812"	.656"	.750"	.328"	.241 lb
4334-Black	15			Black Anodize	1.500"	1.500"	.250"	1.500"	.750"	2.812"	.656"	.750"	.328"	.241 lb
25-4134	25			Clear Anodize	25.00mm	25.00mm	4.00mm	25.00mm	12.70mm	47.00mm	11.00mm	12.50mm	6.80mm	.0299 kg
25-4134-Black	25			Black Anodize	25.00mm	25.00mm	4.00mm	25.00mm	12.70mm	47.00mm	11.00mm	12.50mm	6.80mm	.0299 kg
NEW 30-4134	30			Clear Anodize	30.00mm	30.00mm	4.00mm	30.00mm	12.70mm	57.00mm	13.50mm	15.00mm	6.81mm	.0484 kg
NEW 30-4134-Black	30			Black Anodize	30.00mm	30.00mm	4.00mm	30.00mm	12.70mm	57.00mm	13.50mm	15.00mm	6.81mm	.0484 kg
40-4334	40			Clear Anodize	40.00mm	40.00mm	6.00mm	40.00mm	20.00mm	76.00mm	18.00mm	20.00mm	8.30mm	.1207 kg
40-4334-Black	40			Black Anodize	40.00mm	40.00mm	6.00mm	40.00mm	20.00mm	76.00mm	18.00mm	20.00mm	8.30mm	.1207 kg
NEW 45-4334	45			Clear Anodize	45.00mm	45.00mm	6.00mm	45.00mm	20.00mm	87.00mm	21.00mm	22.50mm	8.33mm	.1669 kg
NEW 45-4334-Black	45			Black Anodize	45.00mm	45.00mm	6.00mm	45.00mm	20.00mm	87.00mm	21.00mm	22.50mm	8.33mm	.1669 kg

* Or comparable

Suggested Hardware (Mount to T-Slot)

Part No.	Series	Qty.	Bolt	T-Nut
3393	10	4	1/4-20 x 1/2" BHSCS	Economy
3320	15	4	5/16-18 x 11/16" FBHSCS	Economy
75-3404	25	4	M6 x 10mm BHSCS	Economy
75-3600	30	4	M6 x 12mm BHSCS	Drop-In
75-3422	40	4	M8 x 16mm BHSCS	Economy
75-3619	45	4	M8 x 18mm BHSCS	Drop-In

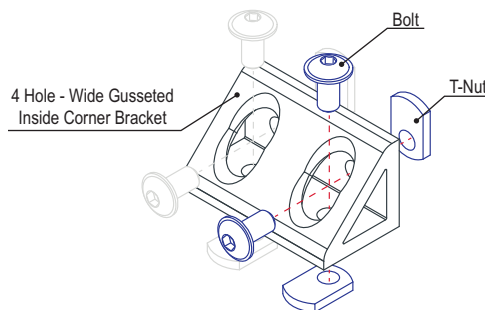

8 Hole - Gusseted Inside Corner Bracket

Part Description:

The 8 hole - gusseted inside corner bracket is a strong, external fastening method that creates a 90 degree connection. It has four holes, comprised of two rows and two columns, on each side of the bracket. It requires no machining services and can provide infinite positioning along the profile T-slot, allowing a large degree of adjustability. The shape of the gusset provides extra material, strengthening the connection. It is a fastening method that can be repositioned and reused.

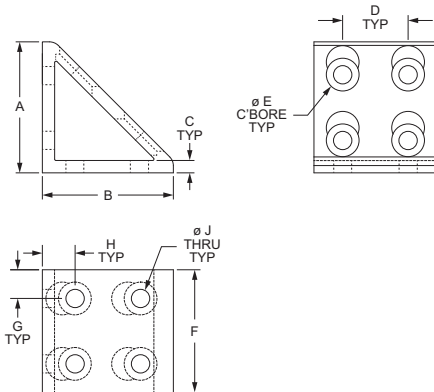

Part No.	Series	Material	Alloy*	Finish	A	B	C	D	E	F	G	H	J	Weight	
4138	10	Aluminum	6105-T5	Clear Anodize	2.000"	2.000"	.188"	1.000"	.500"	1.875"	.438"	.500"	.281"	.170 lb	
4138-Black	10			Black Anodize	2.000"	2.000"	.188"	1.000"	.500"	1.875"	.438"	.500"	.500"	.281"	.170 lb
4338	15			Clear Anodize	3.000"	3.000"	.250"	1.500"	.750"	2.812"	.656"	.750"	.328"	.532 lb	
4338-Black	15			Black Anodize	3.000"	3.000"	.250"	1.500"	.750"	2.812"	.656"	.750"	.328"	.532 lb	
25-4138	25			Clear Anodize	50.00mm	50.00mm	4.00mm	25.00mm	12.70mm	47.00mm	11.00mm	12.50mm	6.80mm	.0662 kg	
25-4138-Black	25			Black Anodize	50.00mm	50.00mm	4.00mm	25.00mm	12.70mm	47.00mm	11.00mm	12.50mm	6.80mm	.0662 kg	
NEW 30-4338	30			Clear Anodize	60.00mm	60.00mm	4.00mm	30.00mm	12.70mm	57.00mm	13.50mm	15.00mm	6.81mm	.1054 kg	
NEW 30-4338-Black	30			Black Anodize	60.00mm	60.00mm	4.00mm	30.00mm	12.70mm	57.00mm	13.50mm	15.00mm	6.81mm	.1054 kg	
40-4338	40			Clear Anodize	80.00mm	80.00mm	6.00mm	40.00mm	20.00mm	76.00mm	18.00mm	20.00mm	8.30mm	.2626 kg	
40-4338-Black	40			Black Anodize	80.00mm	80.00mm	6.00mm	40.00mm	20.00mm	76.00mm	18.00mm	20.00mm	8.30mm	.2626 kg	
NEW 45-4338	45			Clear Anodize	90.00mm	90.00mm	6.00mm	45.00mm	20.00mm	87.00mm	21.00mm	22.50mm	8.33mm	.3633 kg	
NEW 45-4338-Black	45			Black Anodize	90.00mm	90.00mm	6.00mm	45.00mm	20.00mm	87.00mm	21.00mm	22.50mm	8.33mm	.3633 kg	

* Or comparable

Suggested Hardware (Mount to T-Slot)

Part No.	Series	Qty.	Bolt	T-Nut
3393	10	8	1/4-20 x 1/2" BHSCS	Economy
3320	15	8	5/16-18 x 11/16" FBHSCS	Economy
75-3404	25	8	M6 x 10mm BHSCS	Economy
75-3600	30	8	M6 x 12mm BHSCS	Drop-In
75-3422	40	8	M8 x 16mm BHSCS	Economy
75-3619	45	8	M8 x 18mm BHSCS	Drop-In

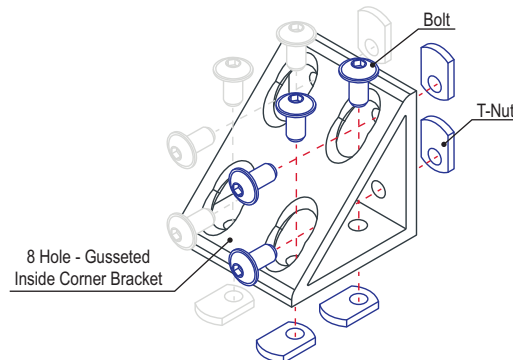

Part Description:

The 3 way - squared corner connector is an external fastening method that is typically used to create a corner connection between three profiles. It is a heavy-duty connection that is simple to use and provides a polished look. The 3 way - squared corner connector requires an end tap machining service (see page 853) on the mating profiles.

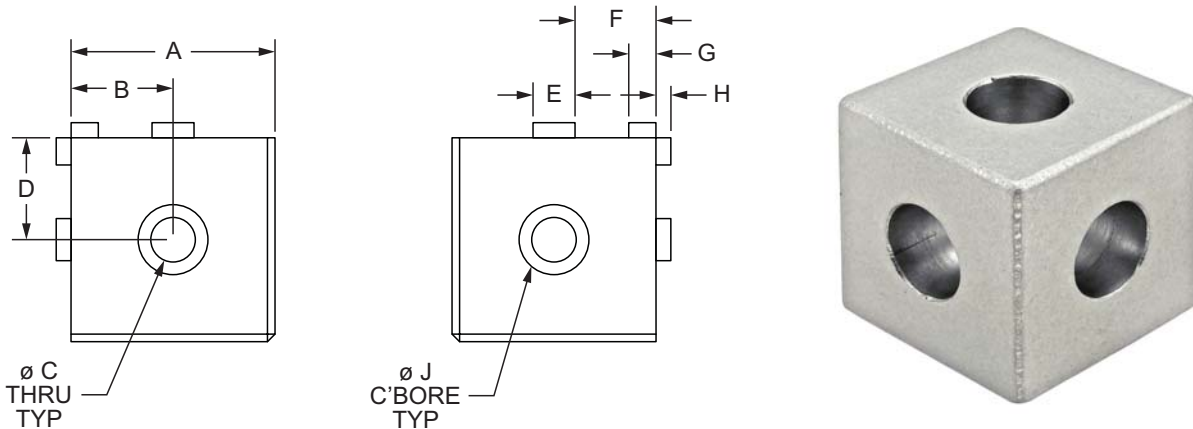

Part No.	Series	Material	Alloy*	Finish	A	B	C	D	E	F	G	H	J	Weight
4042	10	Aluminum	6105-T5	Clear Anodize	1.000"	.500"	.257"	.500"	.244"	.378"	.117"	.087"	.406"	.074 lb
4042-Black	10			Black Anodize	1.000"	.500"	.257"	.500"	.244"	.378"	.117"	.087"	.406"	.074 lb
4442	15			Clear Anodize	1.500"	.750"	.328"	.750"	.310"	.595"	.200"	.110"	.515"	.265 lb
4442-Black	15			Black Anodize	1.500"	.750"	.328"	.750"	.310"	.595"	.200"	.110"	.515"	.265 lb

* Or comparable

Required Machining Services

Machining Type	Machined	Reference Page
Tap Profile End	Mounting Profiles	853

Suggested Hardware (Mount to Profile End)

Part No.	Series	Qty.	Bolt
3017	10	3	1/4-20 x 1" Low Head Socket Cap Screw
3018	15	3	5/16-18 x 1.25" Low Head Socket Cap Screw

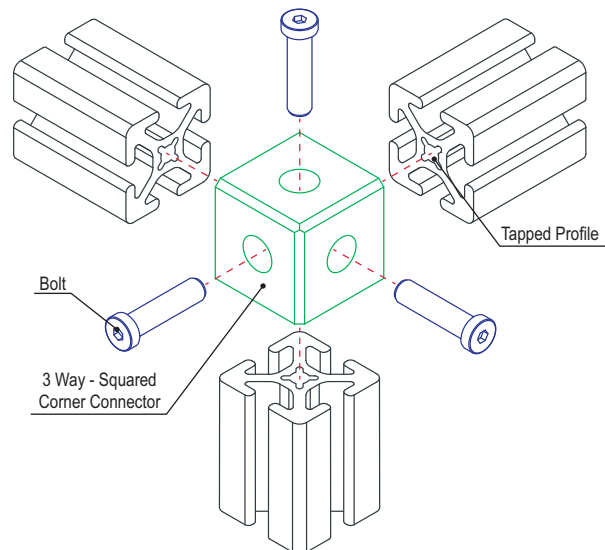

2 Way - Light Squared Corner Connector

Part Description:

The 2 way - light squared corner connector is a die-cast external fastening method that is typically used to create a squared corner connection between two profiles. The fastener is lightweight and has two access holes; it includes the cover caps for the holes, to provide a finished look. The 2 way - light squared corner connector requires an end tap machining service (see page 853) on the mating profiles.

Part Number: 14170 and 14174

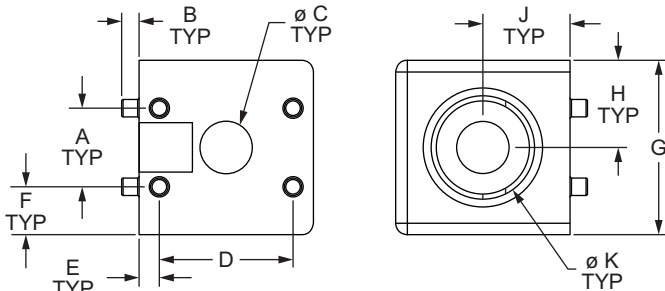

Part Number: 14176, 14172

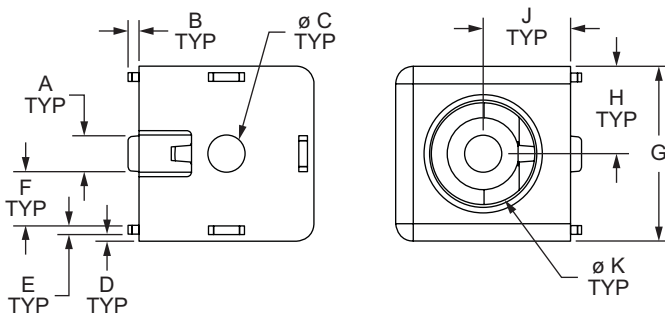

Part No.	Series	Material	Finish	Cap	A	B	C	D	E	F	G	H	J	K	Weight
14176	15	Aluminum	Lacquered	Included	.315"	.118"	.335"	.059"	.098"	.441"	1.500"	.750"	.750"	.705"	.225 lb
14170	30				13.50mm	3.00mm	9.00mm	22.20mm	3.50mm	8.25mm	30.00mm	15.00mm	15.00mm	17.80mm	.0513 kg
14172	40				8.20mm	2.50mm	8.50mm	1.50mm	2.00mm	12.40mm	40.00mm	20.00mm	20.00mm	24.00mm	.1194 kg
14174	45				16.00mm	4.00mm	13.00mm	29.00mm	8.00mm	14.50mm	45.00mm	22.50mm	22.50mm	23.70mm	.1821 kg

Required Machining Services

Machining Type	Machined	Reference Page
Tap Profile End	Mounting Profiles	853

Suggested Hardware (Mount to Profile End)

Part No.	Series	Qty.	Bolt
3118	15	2	5/16-18 x 1" BHSCS
11-8720	30 40	2	M8 x 20mm FHSCS
13003	45	2	M12 x 30mm BHSCS

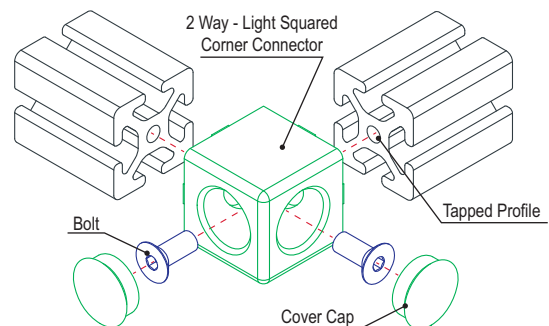

Part Description:

The 3 way - light squared corner connector is a die-cast external fastening method that is typically used to create a squared corner connection between three profiles. The fastener is lightweight and has three access holes; it includes the cover caps for the holes, to provide a finished look. The 3 way - light squared corner connector requires an end tap machining service (see page 853) on the mating profiles.

Part Number: 14177, 14171, 14175

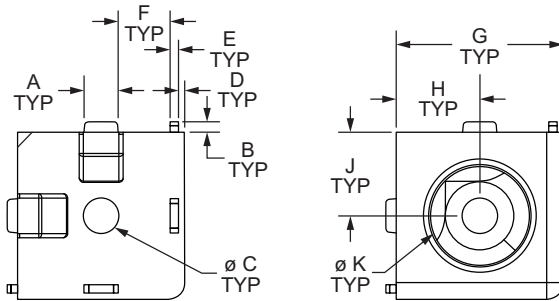

Part Number: 14173

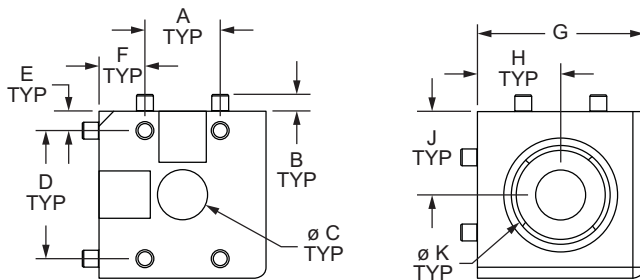

Part No.	Series	Material	Finish	Cap	A	B	C	D	E	F	G	H	J	K	Weight
14177	15	Aluminum	Lacquered	Included	.315"	.118"	.335"	.059"	.098"	.439"	1.500"	.750"	.750"	.705"	.191 lb
14171	30				13.50mm	3.00mm	9.00mm	23.00mm	3.50mm	8.25mm	30.00mm	15.00mm	15.00mm	17.80mm	.0418 kg
14173	40				8.50mm	2.00mm	8.50mm	1.50mm	2.00mm	12.25mm	40.00mm	20.00mm	20.00mm	23.70mm	.1022 kg
14175	45				16.00mm	4.00mm	13.00mm	29.00mm	8.00mm	14.50mm	45.00mm	22.50mm	22.50mm	23.70mm	.1591 kg

Required Machining Services

Machining Type	Machined	Reference Page
Tap Profile End	Mounting Profiles	853

Suggested Hardware (Mount to Profile End)

Part No.	Series	Qty.	Bolt
3118	15	3	5/16-18 x 1" BHSCS
11-8720	30 40	3	M8 x 20mm FHSCS
13003	45	3	M12 x 30mm BHSCS

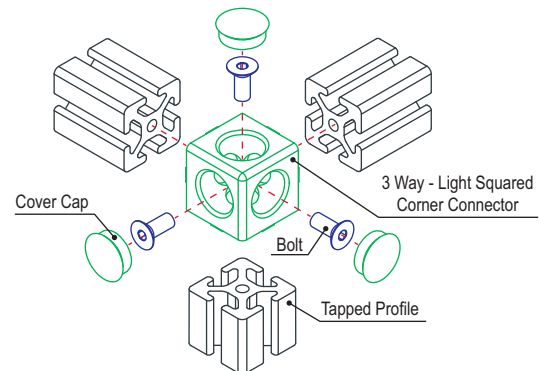

3 Way - Rounded Corner Connector

Part Description:

The 3 way - rounded corner connector is an external fastening method that is typically used to create a curved corner connection between quarter round profiles. It is a heavy-duty connection that is simple to use and provides a finished appearance while the rounded corner prevents sharp edges. The 3 way - rounded corner connector requires an end tap machining service (see page 853) on the mating profiles.

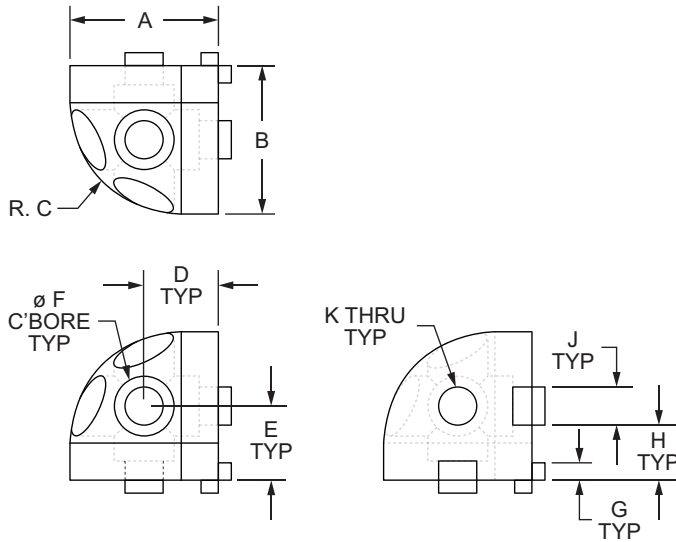

Part No.	Series	Material	Alloy*	Finish	A	B	C	D	E	F	G	H	J	K	Weight
4041	10	Aluminum	6105-T5	Clear Anodize	1.000"	1.000"	.750"	.500"	.500"	.406"	.117"	.378"	.244"	.257"	.049 lb
4041-Black	10			Black Anodize	1.000"	1.000"	.750"	.500"	.500"	.406"	.117"	.378"	.244"	.257"	.049 lb
4441	15			Clear Anodize	1.500"	1.500"	1.125"	.750"	.750"	.515"	.200"	.595"	.310"	.328"	.213 lb
4441-Black	15			Black Anodize	1.500"	1.500"	1.125"	.750"	.750"	.515"	.200"	.595"	.310"	.328"	.213 lb
40-4443	40			Clear Anodize	40.00mm	40.00mm	30.00mm	20.00mm	20.00mm	13.50mm	5.10mm	16.13mm	7.75mm	8.30mm	.1025 kg
40-4443-Black	40			Black Anodize	40.00mm	40.00mm	30.00mm	20.00mm	20.00mm	13.50mm	5.10mm	16.13mm	7.75mm	8.30mm	.1025 kg

* Or comparable

Required Machining Services

Machining Type	Machined	Reference Page
Tap Profile End	Mounting Profiles	853

Suggested Hardware (Mount to Profile End)

Part No.	Series	Qty.	Bolt
3017	10	3	1/4-20 x 1" Low Head Socket Cap Screw
3018	15	3	5/16-18 x 1.25" Low Head Socket Cap Screw
11-8525	40	3	M8 x 25mm SHCS

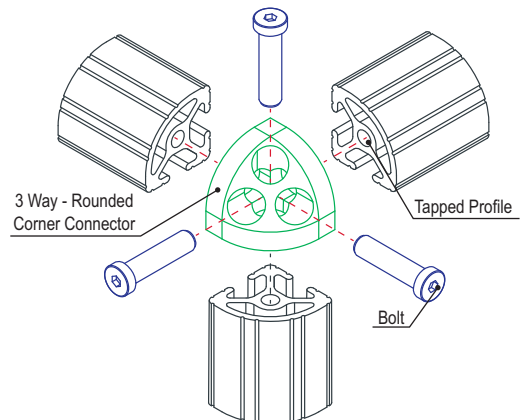

Part Description:

The 3 way - triangular corner connector is an external fastening method that is typically used to create a corner connection between three angled profiles. It is a heavy-duty connection that is simple to use and provides a finished appearance. The 3 way - triangular corner connector requires an end tap machining service (see page 853) on the mating profiles. The suggested hardware can be found below or on page 392.

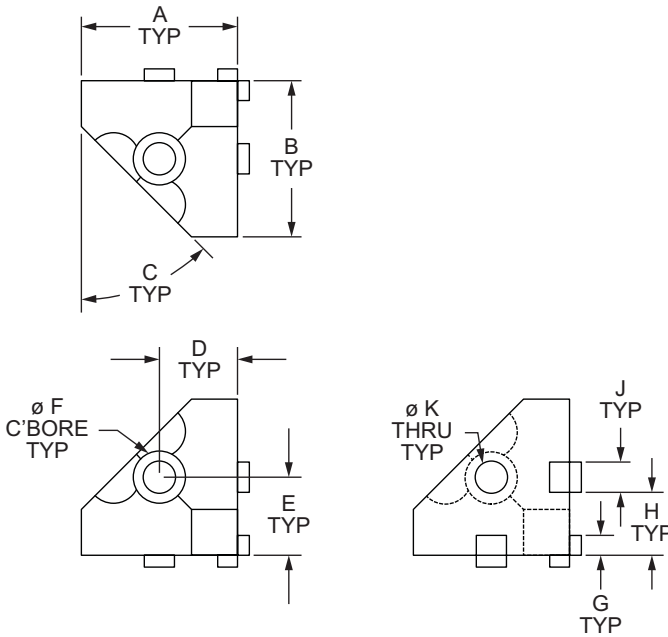

Part No.	Series	Material	Alloy*	Finish	A	B	C	D	E	F	G	H	J	K	Weight
40-4441	40	Aluminum	6105-T5	Clear Anodize	40.00mm	40.00mm	45°	20.00mm	20.00mm	13.50mm	5.10mm	16.13mm	7.75mm	8.30mm	.0677 kg
40-4441-Black	40	Aluminum	6105-T5	Black Anodize	40.00mm	40.00mm	45°	20.00mm	20.00mm	13.50mm	5.10mm	16.13mm	7.75mm	8.30mm	.0677 kg

* Or comparable

Required Machining Services

Machining Type	Machined	Reference Page
Tap Profile End	Mounting Profiles	853

Suggested Hardware (Mount to Profile End)

Part No.	Series	Qty.	Bolt
11-8525	40	3	M8 x 25mm SHCS

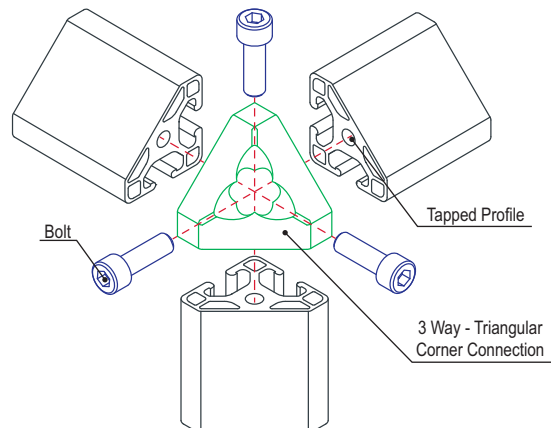

Standard Angle Clamp Block

Part Description:

The standard angle clamp block is typically mounted to the T-slot. The tab grips into the mating profile to help align and hold the clamp, enabling adjustments and a range of various angles. The standard angle clamp block is sold in pairs and requires no machining services. The suggested mounting hardware is included.

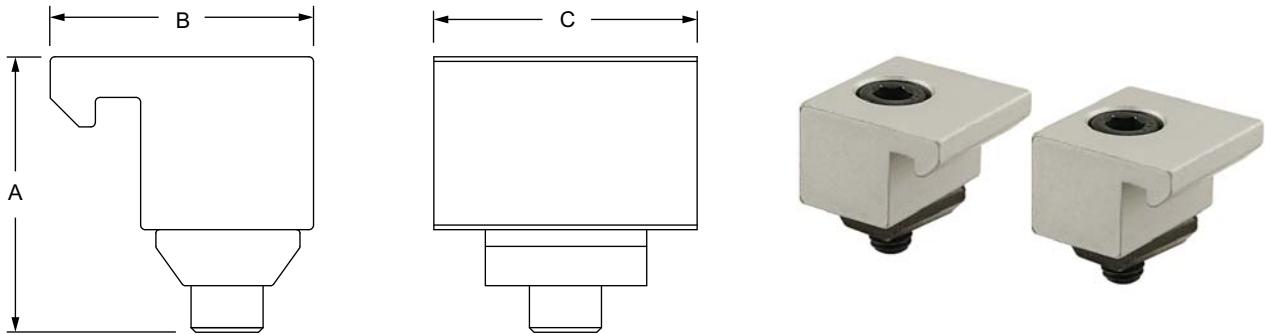

Part No.	Series	Material	Alloy*	Finish	A	B	C	Weight
4174	10	Aluminum	6105-T5	Clear Anodize	.690"	.710"	.710"	.063 lb
4174-Black	10			Black Anodize	.690"	.710"	.710"	.063 lb
4468	15			Clear Anodize	1.195"	1.142"	1.142"	.218 lb
4468-Black	15			Black Anodize	1.195"	1.142"	1.142"	.218 lb

* Or comparable

Included Hardware (Mount to T-Slot)

Part No.	Series	Qty.	Description
3048	10	2	10-32 x 1/2" SHCS
3276	10	2	Slide-in Economy T-Nut
3119	15	2	5/16-18 x 7/8" SHCS
3203	15	2	Standard Slide-in T-Nut

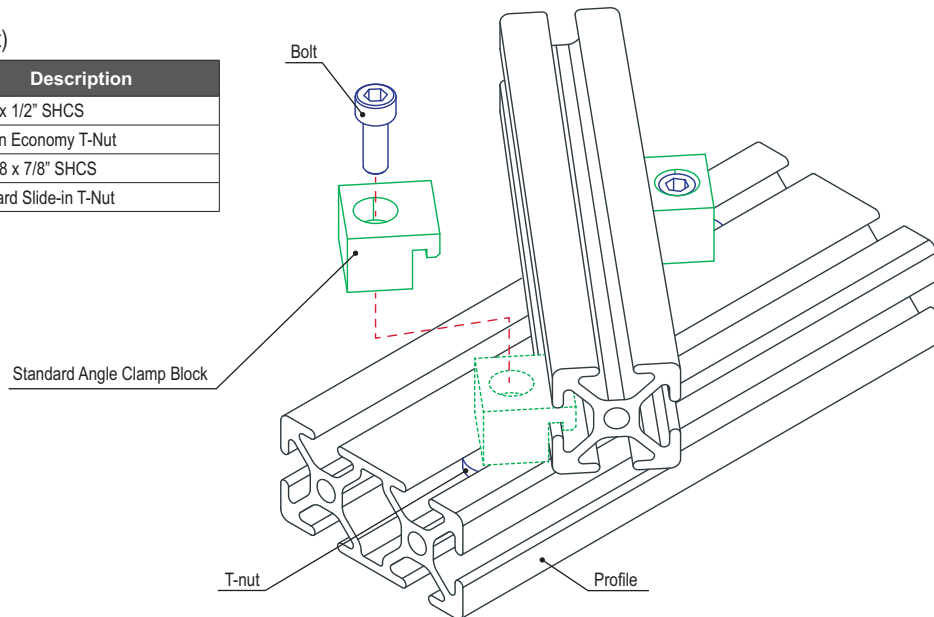

Part Description:

The economy angle clamp block is commonly used to connect profiles at variable angles and provide a large degree of adjustability. The tab grips into the mating profile to help align and hold the clamp. The economy angle clamp block requires no machining services.

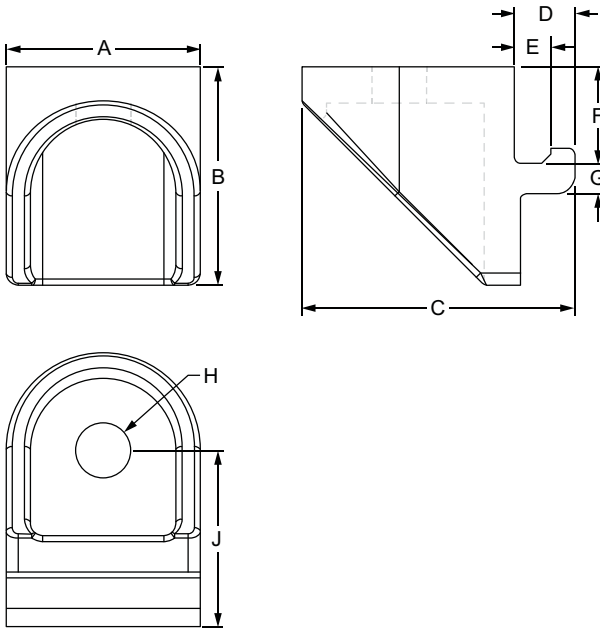

Part No.	Series	A	B	C	D	E	F	G	H	J	Weight
14117	40	32.00mm	36.00mm	45.00mm	10.00mm	6.00mm	15.90mm	5.00mm	9.00mm	26.00mm	.1026 kg

Material Specifications

Material	Process	Finish
Zinc	Die Cast	Powder Coat

Suggested Hardware (Mount to T-Slot)

Part No.	Series	Qty.	Bolt	T-Nut
75-3625	40	1	M8 x 16mm SHCS	Slide-In

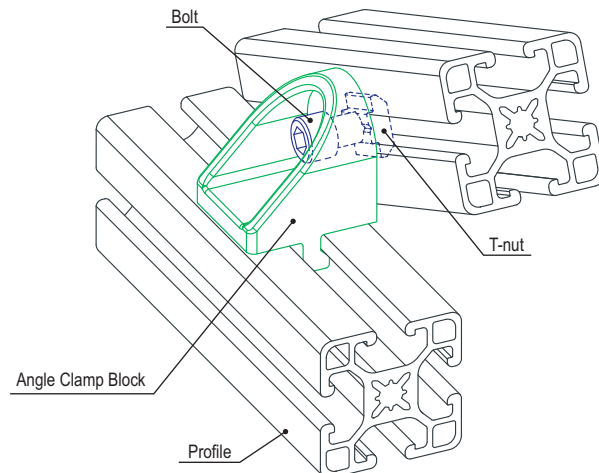

2 Hole - Pivot Joint

Part Description:

The 2 hole - pivot joint is an external fastening method that is lightweight yet sturdy. It is easy to use and is compatible with most metric profiles. This connector can either mount to the end of a profile, which would require an end tap (see page 853), or the slot tabs can be removed for mounting directly to the T-slot without any required machining services. The screws on the arms can be adjusted for movement or fixed in one position. The suggested hardware for the 2 hole - pivot joint can be found on page 337.

Part Number: 14011, 14016

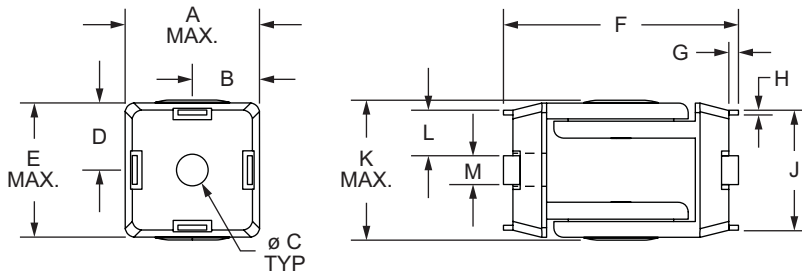

Part Number: 14014, 14017

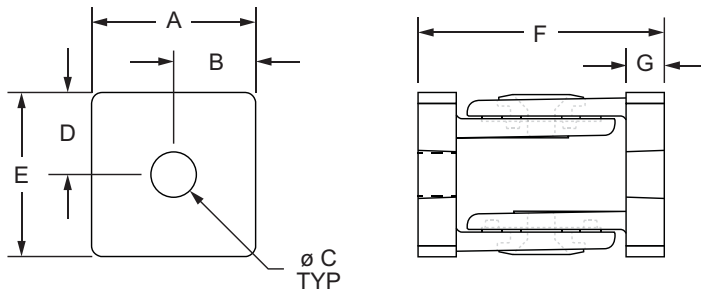

Part Number: 14018 and 14019

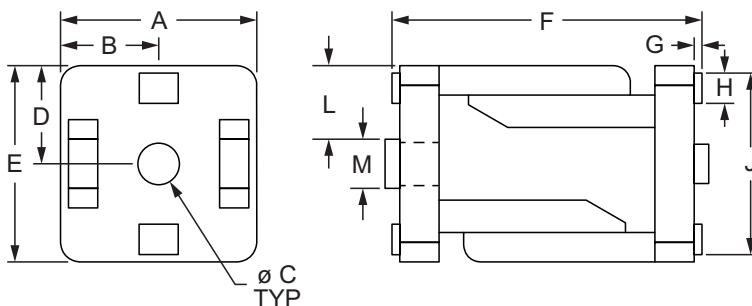

CONTINUE →

FASTENERS



2 Hole - Pivot Joint (Continued)

Part No.	Series	A	B	C	D	E	F	G	H	J	K	L	M	Weight
14011*	10 25	28.00mm	14.00mm	6.60mm	14.00mm	28.00mm	49.00mm	2.00mm	1.00mm	25.00mm	29.20mm	9.50mm	6.00mm	.1225 kg
14017**	15	1.570"	.790"	.340"	.790"	1.570"	2.520"	.079"	.039"	1.378"	—	.531"	.315"	.641 lb
14014**	30	30.00mm	15.00mm	8.30mm	15.00mm	30.00mm	45.00mm	7.00mm	—	—	—	—	—	.1412 kg
14016*	30	30.00mm	15.00mm	8.30mm	15.00mm	30.00mm	50.00mm	2.50mm	1.00mm	29.00mm	—	10.50mm	8.30mm	.1375 kg
14018***	40	40.00mm	20.00mm	8.50mm	20.00mm	40.00mm	63.20mm	1.60mm	6.20mm	37.00mm	—	15.00mm/ 16.00mm	8.00mm/ 10.00mm	.2699 kg
14019***	45	45.00mm	22.50mm	8.50mm	22.50mm	45.00mm	63.60mm	1.80mm	6.20mm	42.00mm	—	16.00mm/ 17.00mm	8.00mm/ 10.00mm	.3268 kg

* Break off tabs

** No slot tabs available

*** Insert tabs available in M8 and M10

Material Specifications

Material	Process	Finish
Zinc	Die Cast	Powder Coat

2-Hole Pivot Joint Machining Services

Machining Type	Profile Machined	Reference Page
End Tap	Mounting Profile	853

Suggested Hardware (Mount to T-Slot)

Part No.	Series	Qty.	Bolt	T-Nut
3491	10	2	1/4-20 x 1/2" SHCS	Economy
3456	15	2	5/16-18 x 5/8" SHCS	Drop-In
75-3592	25	2	M6 x 14mm SHCS	Slide-In
75-3595	30	2	M6 x 16mm SHCS	Drop-In
75-3625	40	2	M8 x 16mm SHCS	Slide-In
75-3623	45	2	M8 x 16mm SHCS	Drop-In

Suggested Hardware (Mount to Profile End)

Part No.	Series	Qty.	Bolt
3064	10	2	1/4-20 x 3/4" SHCS
3122	15	2	5/16-18 x 1" SHCS
11-6518	25	2	M6 x 18mm SHCS
11-8525*	30 40 45	2	M8 x 25mm SHCS
14196*	45	2	Threaded Insert

* 45 series requires two SHCS and two threaded inserts

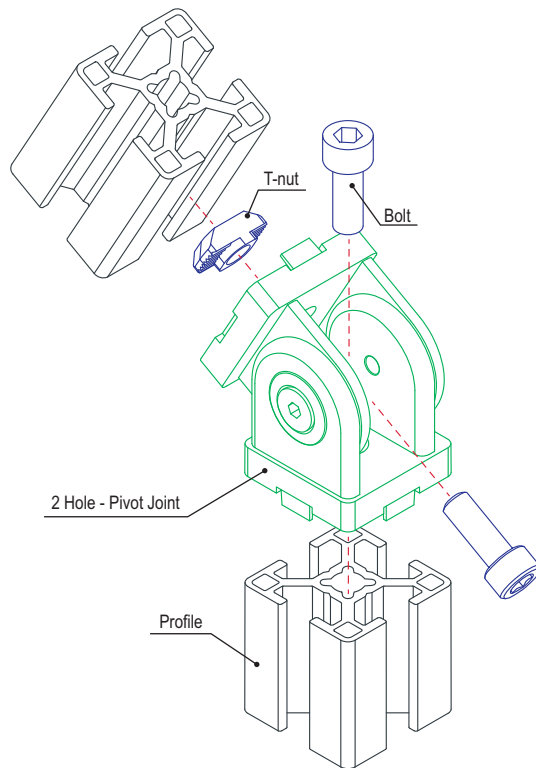

3 Hole - Triangular Pivot Plate

Part Description:

The 3 hole - triangular pivot plate is an external connection method that can be used either with a nub or mounted directly to the T-slot. It is typically used to create a structured angle connection between profiles. This fastening option provides a long-lasting connection and requires no machining services. It can be easily assembled, lending itself to repositioning and reuse. **Tip:** Use double slide-in economy T-nuts (pg. 364) to save time and money. Pre-load your hardware prior to connecting profiles to simplify your assembly and save time.

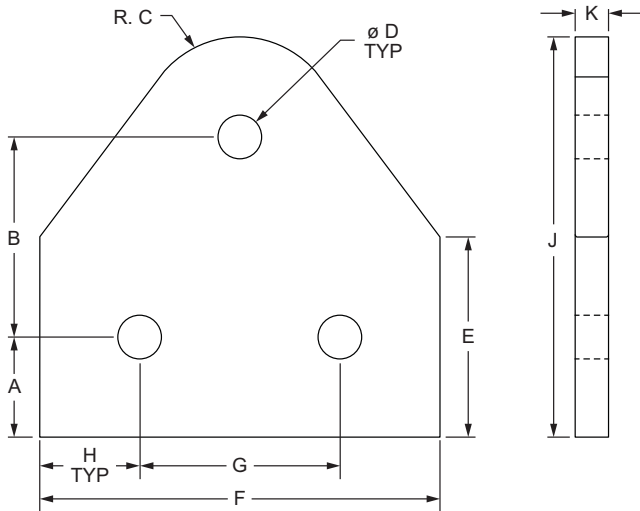

Part No.	Series	Color	A	B	C	D	E	F	G	H	J	K	Weight
4372	15	Clear	.750"	1.500"	.750"	.328"	1.500"	3.000"	1.500"	.750"	3.000"	.250"	.168 lb
4372-Black	15	Black	.750"	1.500"	.750"	.328"	1.500"	3.000"	1.500"	.750"	3.000"	.250"	.168 lb
40-4372	40	Clear	20.00mm	40.00mm	20.00mm	8.30mm	40.00mm	80.00mm	40.00mm	20.00mm	80.00mm	6.00mm	.0811 kg
40-4372-Black	40	Black	20.00mm	40.00mm	20.00mm	8.30mm	40.00mm	80.00mm	40.00mm	20.00mm	80.00mm	6.00mm	.0811 kg

Material Specifications

Material	Alloy*	Process	Finish
Aluminum	6105-T5	Milled	Anodize

* Or comparable

Suggested Hardware (Mount to T-slot)

Part No.	Series	Qty.	Bolt	T-Nut
3320	15	3	5/16-18 x 11/16" FBHSCS	Economy
75-3422	40	3	M8 x 16mm BHSCS	Economy

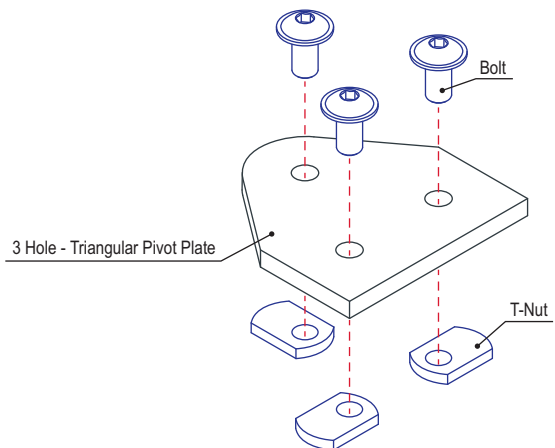



Part Description:

The 3 hole - recessed straight pivot plate is an external connection method that is intended to be used in pairs to create a custom angle between profiles. The recess replaces the need for a nub in a pivot assembly. This fastening option provides a long-lasting connection and requires no machining services. It can be easily assembled, lending itself to repositioning and reuse. **Tip:** Use double slide-in economy T-nuts (pg. 364) to save time and money. Pre-load your hardware prior to connecting profiles to simplify your assembly and save time.

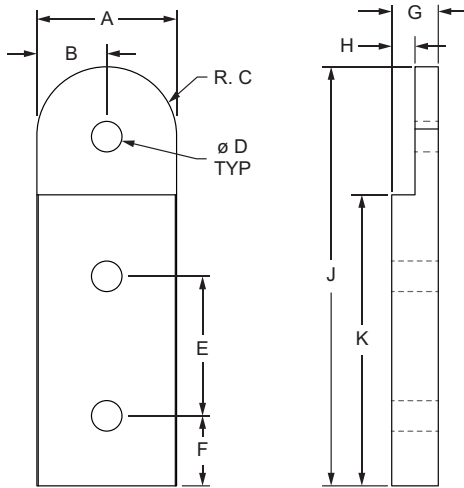

Part No.	Series	Color	A	B	C	D	E	F	G	H	J	K	Weight
4390	15	Clear	1.500"	.750"	.755"	.328"	1.500"	.750"	.500"	.250"	4.500"	3.000"	.255 lb
4390-Black	15	Black	1.500"	.750"	.755"	.328"	1.500"	.750"	.500"	.250"	4.500"	3.000"	.255 lb
40-4390	40	Clear	40.00mm	20.00mm	20.00mm	8.30mm	40.00mm	20.00mm	12.00mm	6.00mm	120.00mm	80.00mm	.0550 kg
40-4390-Black	40	Black	40.00mm	20.00mm	20.00mm	8.30mm	40.00mm	20.00mm	12.00mm	6.00mm	120.00mm	80.00mm	.0550 kg

Material Specifications

Material	Alloy*	Process	Finish
Aluminum	6105-T5	Milled	Anodize

* Or comparable

Suggested Hardware (Mount to T-Slot)

Part No.	Series	Qty.	Bolt	T-Nut	Washer
3443	15	2	5/16-18 x 1" BHSCS	Economy	Yes
75-3427	40	2	M8 x 25mm BHSCS	Economy	Yes

Suggested Hardware (Mount to Pivot Plate)

Part No.	Series	Qty.	Description
3446	15	1	5/16-18 x 7/8" SHCS, Washer & Hex Nut
75-3434	40	1	M8 x 25mm SHCS, Washer & Hex Nut

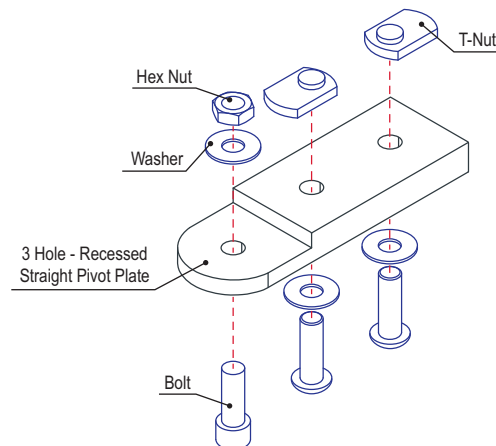

3 Hole - Recessed Triangular Pivot Plate

Part Description:

The 3 hole - recessed triangular pivot plate is an external connection method that is intended to be used in pairs to create a custom angle between profiles. The recess replaces the need for a nub in a pivot assembly. It is typically used to create a structured angled connection between profiles. This fastening option provides a long-lasting connection and requires no machining services. It can be easily assembled, lending itself to repositioning and reuse. **Tip:** Use double slide-in economy T-nuts (pg. 364) to save time and money. Pre-load your hardware prior to connecting profiles to simplify your assembly and save time.

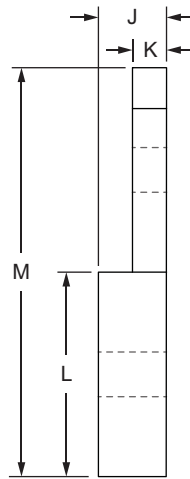
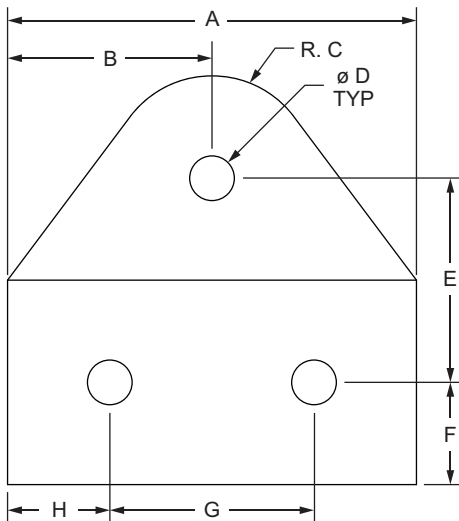

Part No.	Series	Color	A	B	C	D	E	F	G	H	J	K	L	M	Weight
4392	15	Clear	3.000"	1.500"	.750"	.328"	1.500"	.750"	1.500"	.750"	.500"	.250"	1.500"	3.000"	.272 lb
4392-Black	15	Black	3.000"	1.500"	.750"	.328"	1.500"	.750"	1.500"	.750"	.500"	.250"	1.500"	3.000"	.272 lb

Material Specifications

Material	Alloy*	Process	Finish
Aluminum	6105-T5	Milled	Anodize

* Or comparable

Suggested Hardware (Mount to T-Slot)

Part No.	Series	Qty.	Bolt	T-Nut	Washer
3443	15	2	5/16-18 x 1" BHSCS	Economy	Yes

Suggested Hardware (Mount to Pivot Plate)

Part No.	Series	Qty.	Description
3446	15	1	5/16-18 x 7/8" SHCS, Washer & Hex Nut

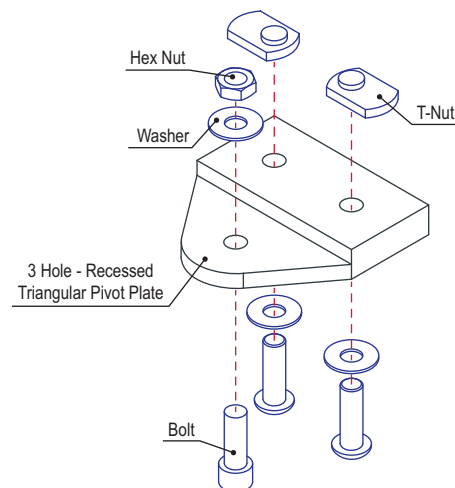



5 Hole - Triangular Pivot Plate

Part Description:

The 5 hole - triangular pivot plate is a strong external connection method that is typically used with a nub to create a structured angle connection between profiles. This fastening option provides a long-lasting connection and requires no machining services. It can be easily assembled, lending itself to repositioning and reuse. **Tip:** Use double slide-in economy T-nuts (pg. 364) to save time and money. Pre-load your hardware prior to connecting profiles to simplify your assembly and save time.

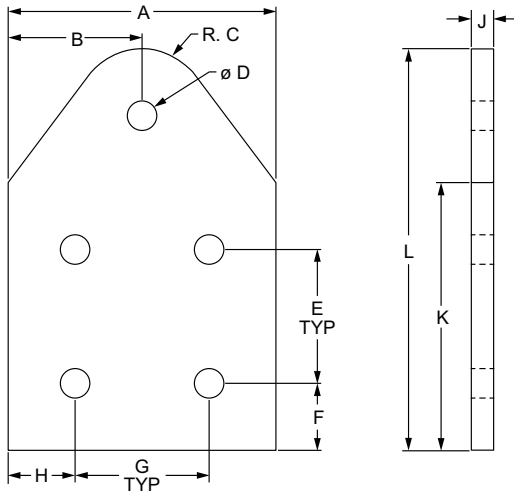

Part No.	Series	Color	A	B	C	D	E	F	G	H	J	K	L	Weight
4371	15	Clear	3.000"	1.500"	.750"	.328"	1.500"	.750"	1.500"	.750"	.250"	3.000"	4.500"	.267 lb
4371-Black	15	Black	3.000"	1.500"	.750"	.328"	1.500"	.750"	1.500"	.750"	.250"	3.000"	4.500"	.267 lb

Material Specifications

Material	Alloy*	Process	Finish
Aluminum	6105-T5	Milled	Anodize

* Or comparable

Suggested Hardware (Mount to T-Slot)

Part No.	Series	Qty.	Bolt	T-Nut
3320	15	4	5/16-18 x 11/16" FBHSCS	Economy

Suggested Hardware (Mount to Pivot Nub)

Part No.	Series	Qty.	Bolt
3330	15	1	5/16-18 x 11/16" FBHSCS

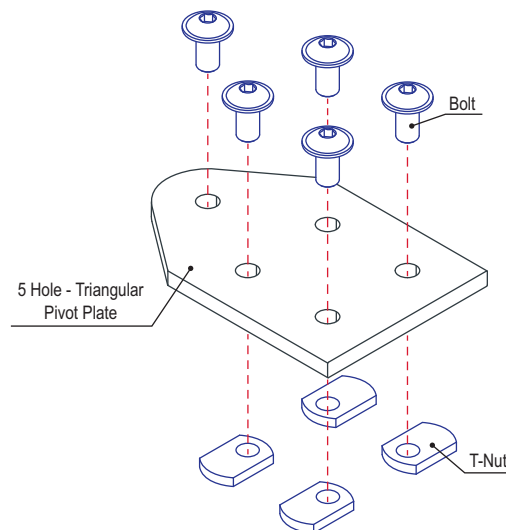

5 Hole - Recessed Triangular Pivot Plate

Part Description:

The 5 hole - recessed triangular pivot plate is an external connection method that is intended to be used in pairs to create a custom angle between profiles. The recess replaces the need for a nub in a pivot assembly. This fastening option provides a long-lasting connection and requires no machining services. It can be easily assembled, lending itself to repositioning and reuse. **Tip:** Use double slide-in economy T-nuts (pg. 364) to save time and money. Pre-load your hardware prior to connecting profiles to simplify your assembly and save time.

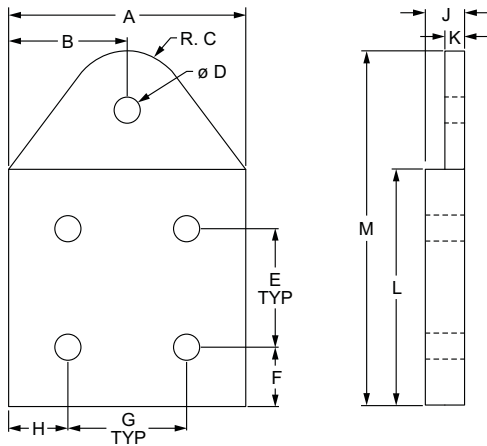

Part No.	Series	Color	A	B	C	D	E	F	G	H	J	K	L	M	Weight
4394	15	Clear	3.000"	1.500"	.750"	.328"	1.500"	.750"	1.500"	.750"	.500"	.250"	3.000"	4.500"	.485 lb
4394-Black	15	Black	3.000"	1.500"	.750"	.328"	1.500"	.750"	1.500"	.750"	.500"	.250"	3.000"	4.500"	.485 lb
40-4394	40	Clear	80.00mm	40.00mm	20.00mm	8.30mm	40.00mm	20.00mm	40.00mm	20.00mm	12.00mm	6.00mm	80.00mm	120.00mm	.2287 kg
40-4394-Black	40	Black	80.00mm	40.00mm	20.00mm	8.30mm	40.00mm	20.00mm	40.00mm	20.00mm	12.00mm	6.00mm	80.00mm	120.00mm	.2287 kg

Material Specifications

Material	Alloy*	Process	Finish
Aluminum	6105-T5	Milled	Anodize

* Or comparable

Suggested Hardware (Mount to T-Slot)

Part No.	Series	Qty.	Bolt	T-Nut	Washer
3443	15	4	5/16-18 x 1" BHSCS	Economy	Yes
75-3427	40	4	M8 x 25mm BHSCS	Economy	Yes

Suggested Hardware (Mount to Pivot Plate)

Part No.	Series	Qty.	Description
3446	15	1	5/16-18 x 7/8" SHCS, Washer & Hex Nut
75-3434	40	1	M8 x 25mm SHCS, Washer & Hex Nut

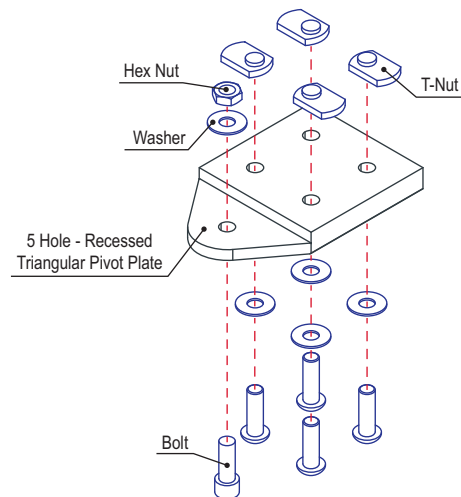

0 Degree Structural Pivot Nub

Part Description:

The 0 degree structural pivot nub is an external fastening method commonly used as a connection hub to create a structural pivot ranging from 0-180 degrees parallel to the mounting profile. It has a slot tab that helps prevent the nub from rotating as well as assists with alignment in the T-slot. The 0 degree structural pivot nub requires no machining services and can be easily assembled, lending itself to repositioning and reuse.

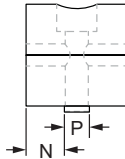
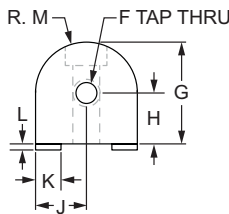
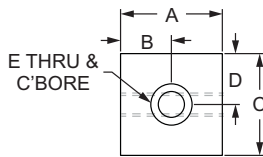

Part No.	Series	Color	A	B	C	D	E	F	G	H	J	K	L	M	N	P	Weight
4187	10	Clear	1.000"	.500"	1.000"	.500"	1/4-20	1/4-20	1.000"	.500"	.500"	.250"	.060"	.500"	.377"	.245"	.102 lb
4187-Black	10	Black	1.000"	.500"	1.000"	.500"	1/4-20	1/4-20	1.000"	.500"	.500"	.250"	.060"	.500"	.377"	.245"	.102 lb
4387	15	Clear	1.500"	.750"	1.500"	.750"	5/16-18	5/16-18	1.500"	.750"	.750"	.312"	.100"	.750"	.594"	.312"	.312 lb
4387-Black	15	Black	1.500"	.750"	1.500"	.750"	5/16-18	5/16-18	1.500"	.750"	.750"	.312"	.100"	.750"	.594"	.312"	.312 lb
25-4187	25	Clear	25.00mm	12.50mm	25.00mm	12.50mm	M6 x 1.0	M6 x 1.0	25.00mm	12.50mm	12.50mm	6.15mm	1.10mm	12.50mm	9.35mm	6.30mm	.0405 kg
25-4187-Black	25	Black	25.00mm	12.50mm	25.00mm	12.50mm	M6 x 1.0	M6 x 1.0	25.00mm	12.50mm	12.50mm	6.15mm	1.10mm	12.50mm	9.35mm	6.30mm	.0405 kg
40-4387	40	Clear	40.00mm	20.00mm	40.00mm	20.00mm	M8 x 1.25	M8 x 1.25	40.00mm	20.00mm	20.00mm	7.92mm	2.13mm	20.00mm	16.03mm	7.92mm	.1549 kg
40-4387-Black	40	Black	40.00mm	20.00mm	40.00mm	20.00mm	M8 x 1.25	M8 x 1.25	40.00mm	20.00mm	20.00mm	7.92mm	2.13mm	20.00mm	16.03mm	7.92mm	.1549 kg

Material Specifications

Material	Alloy*	Process	Finish
Aluminum	6105-T5	Milled	Anodize

* Or comparable

Included Hardware (Mount Nub to T-Slot)

Part No.	Series	Qty.	Bolt	T-Nut
3306	10	1	1/4-20 x 1" SHCS	Economy
3613	15	1	5/16-18 x 1.5" SHCS	Economy
75-3415	25	1	M6 x 25mm SHCS	Economy
75-3479	40	1	M8 x 40mm SHCS	Economy

Suggested Hardware (Mount Arm to Nub)

Part No.	Series	Qty.	Bolt
3342	10	2	1/4-20 x 1/2" FBHSCS
3330	15	2	5/16-18 x 11/16" FBHSCS
13-6312	25	2	M6 x 12mm BHSCS
13-8316	40	2	M8 x 16mm BHSCS

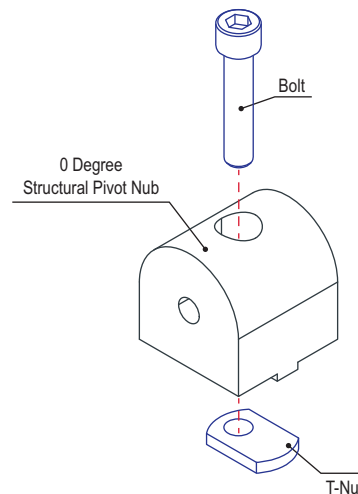

90 Degree Structural Pivot Nub

Part Description:

The 90 degree structural pivot nub is an external fastening method commonly used as a connection hub to create a structural pivot ranging from 0-180 degrees perpendicular to the mounting profile. It has a slot tab that helps prevent the nub from rotating as well as assists with alignment in the T-slot. The 90 degree structural pivot nub requires no machining services and can be easily assembled, lending itself to repositioning and reuse.

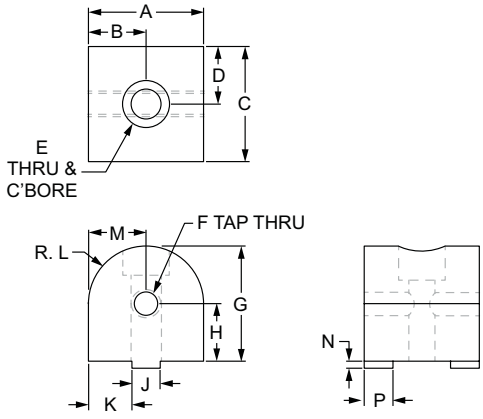

FASTENERS

Part No.	Series	Color	A	B	C	D	E	F	G	H	J	K	L	M	N	P	Weight
4188	10	Clear	1.000"	.500"	1.000"	.500"	1/4-20	1/4-20	1.000"	.500"	.245"	.377"	.500"	.500"	.060"	.250"	.102 lb
4188-Black	10	Black	1.000"	.500"	1.000"	.500"	1/4-20	1/4-20	1.000"	.500"	.245"	.377"	.500"	.500"	.060"	.250"	.102 lb
4388	15	Clear	1.500"	.750"	1.500"	.750"	5/16-18	5/16-18	1.500"	.750"	.312"	.594"	.750"	.750"	.100"	.312"	.324 lb
4388-Black	15	Black	1.500"	.750"	1.500"	.750"	5/16-18	5/16-18	1.500"	.750"	.312"	.594"	.750"	.750"	.100"	.312"	.324 lb
25-4188	25	Clear	25.00mm	12.50mm	25.00mm	12.50mm	M6 x 1.0	M6 x 1.0	25.00mm	12.50mm	6.30mm	9.35mm	12.50mm	12.50mm	1.10mm	6.15mm	.0402 kg
25-4188-Black	25	Black	25.00mm	12.50mm	25.00mm	12.50mm	M6 x 1.0	M6 x 1.0	25.00mm	12.50mm	6.30mm	9.35mm	12.50mm	12.50mm	1.10mm	6.15mm	.0402 kg
40-4388	40	Clear	40.00mm	20.00mm	40.00mm	20.00mm	M8 x 1.25	M8 x 1.25	40.00mm	20.00mm	7.92mm	16.03mm	20.00mm	20.00mm	2.13mm	7.92mm	.1545 kg
40-4388-Black	40	Black	40.00mm	20.00mm	40.00mm	20.00mm	M8 x 1.25	M8 x 1.25	40.00mm	20.00mm	7.92mm	16.03mm	20.00mm	20.00mm	2.13mm	7.92mm	.1545 kg

Material Specifications

Material	Alloy*	Process	Finish
Aluminum	6105-T5	Milled	Anodize

* Or comparable

Included Hardware (Mount Nub to T-Slot)

Part No.	Series	Qty.	Bolt	T-Nut
3306	10	1	1/4-20 x 1" SHCS	Economy
3613	15	1	5/16-18 x 1.5" SHCS	Economy
75-3415	25	1	M6 x 25mm SHCS	Economy
75-3479	40	1	M8 x 40mm SHCS	Economy

Suggested Hardware (Mount Arm to Nub)

Part No.	Series	Qty.	Bolt
3342	10	2	1/4-20 x 1/2" FBHSCS
3330	15	2	5/16-18 x 11/16" FBHSCS
13-6312	25	2	M6 x 12mm BHSCS
13-8316	40	2	M8 x 16mm BHSCS

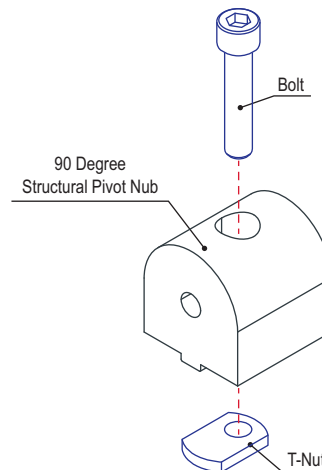



Part Description:

The universal structural pivot nub is an external fastening method commonly used as a connection hub to create a structural pivot ranging from 0-180 degrees either parallel or perpendicular to the mounting profile. The universal structural pivot nub requires no machining services and can be easily assembled, lending itself to repositioning and reuse.

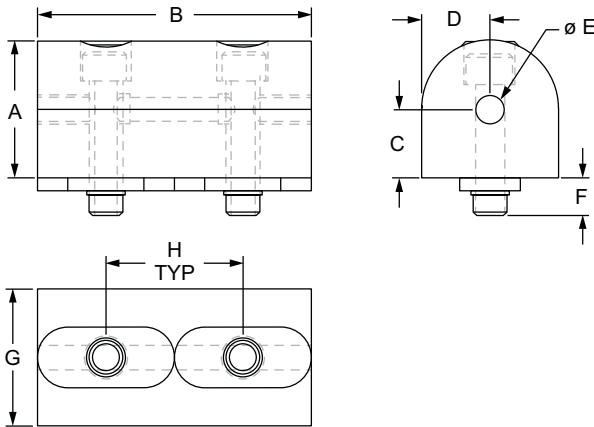

Part No.	Series	Color	A	B	C	D	E	F	G	H	Weight
4186	10	Clear	1.000"	2.000"	.500"	.500"	1/4-20	.260"	1.000"	1.000"	.202 lb
4186-Black	10	Black	1.000"	2.000"	.500"	.500"	1/4-20	.260"	1.000"	1.000"	.202 lb
4386	15	Clear	1.500"	3.000"	.750"	.750"	5/16-18	.450"	1.500"	1.500"	.648 lb
4386-Black	15	Black	1.500"	3.000"	.750"	.750"	5/16-18	.450"	1.500"	1.500"	.648 lb
25-4186	25	Clear	25.00mm	50.00mm	12.50mm	12.50mm	M6 x 1.0	6.89mm	25.00mm	25.00mm	.0885 kg
25-4186-Black	25	Black	25.00mm	50.00mm	12.50mm	12.50mm	M6 x 1.0	6.89mm	25.00mm	25.00mm	.0885 kg
40-4386	40	Clear	40.00mm	80.00mm	20.00mm	20.00mm	M8 x 1.25	11.43mm	40.00mm	40.00mm	.3393 kg
40-4386-Black	40	Black	40.00mm	80.00mm	20.00mm	20.00mm	M8 x 1.25	11.43mm	40.00mm	40.00mm	.3393 kg

Material Specifications

Material	Alloy*	Process	Finish
Aluminum	6105-T5	Milled	Anodize

* Or comparable

Included Hardware (Mount Nub to T-Slot)

Part No.	Series	Qty.	Bolt	T-Nut
3306	10	2	1/4-20 x 1" SHCS	Economy
3613	15	2	5/16-18 x 1.5" SHCS	Economy
75-3415	25	2	M6 x 25mm SHCS	Economy
75-3479	40	2	M8 x 40mm SHCS	Economy

Suggested Hardware (Mount Arm to Nub)

Part No.	Series	Qty.	Bolt
3342	10	2	1/4-20 x 1/2" FBHSCS
3330	15	2	5/16-18 x 11/16" FBHSCS
13-6312	25	2	M6 x 12mm BHSCS
13-8316	40	2	M8 x 16mm BHSCS

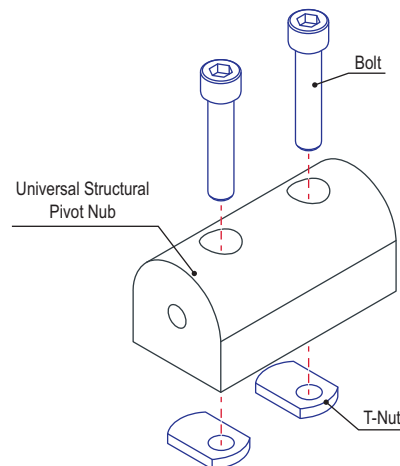

0 Degree Structural Right Angle Pivot Nub

Part Description:

The 0 degree structural right angle pivot nub is an external fastening method commonly used as a connection hub to create a structural pivot ranging from 0-90 degrees parallel to the mounting profile. It has a slot tab that helps prevent the nub from rotating as well as assists with alignment in the T-slot. The 0 degree structural right angle pivot nub requires no machining services and can be easily assembled, lending itself to repositioning and reuse.

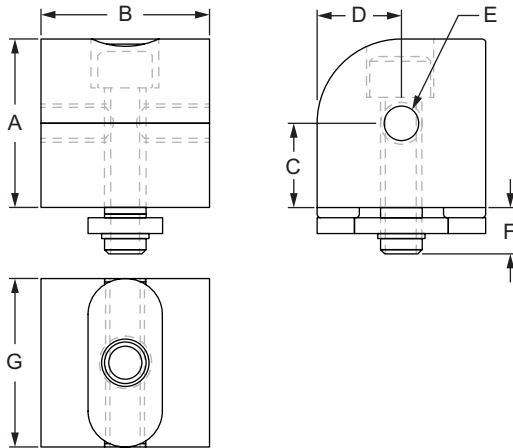

Part No.	Series	Color	A	B	C	D	E	F	G	Weight
4001	10	Clear	1.000"	1.000"	.500"	.500"	1/4-20	.275"	1.000"	.107 lb
4001-Black	10	Black	1.000"	1.000"	.500"	.500"	1/4-20	.275"	1.000"	.107 lb
4401	15	Clear	1.500"	1.500"	.750"	.750"	5/16-18	.450"	1.500"	.344 lb
4401-Black	15	Black	1.500"	1.500"	.750"	.750"	5/16-18	.450"	1.500"	.344 lb

Material Specifications

Material	Alloy*	Process	Finish
Aluminum	6105-T5	Milled	Anodize

* Or comparable

Included Hardware (Mount Nub to T-Slot)

Part No.	Series	Qty.	Bolt	T-Nut
3306	10	1	1/4-20 x 1" SHCS	Economy
3613	15	1	5/16-18 x 1.5" SHCS	Economy

Suggested Hardware (Mount Arm to Nub)

Part No.	Series	Qty.	Bolt
3342	10	2	1/4-20 x 1/2" FBHSCS
3330	15	2	5/16-18 x 11/16" FBHSCS

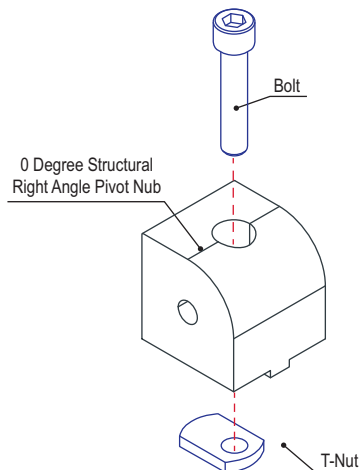

Part Description:

The 90 degree structural right angle pivot nub is an external fastening method commonly used as a connection hub to create a structural pivot ranging from 0-90 degrees perpendicular to the mounting profile. It has a slot tab that helps prevent the nub from rotating as well as assists with alignment in the T-slot. The 90 degree structural right angle pivot nub requires no machining services and can be easily assembled, lending itself to repositioning and reuse.

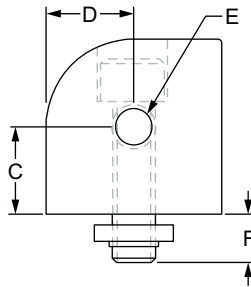
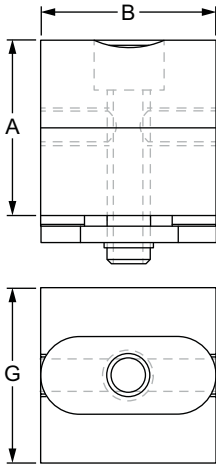

Part No.	Series	Color	A	B	C	D	E	F	G	Weight
4002	10	Clear	1.000"	1.000"	.500"	.500"	1/4-20	.275"	1.000"	.106 lb
4002-Black	10	Black	1.000"	1.000"	.500"	.500"	1/4-20	.275"	1.000"	.107 lb
4402	15	Clear	1.500"	1.500"	.750"	.750"	5/16-18	.450"	1.500"	.338 lb
4402-Black	15	Black	1.500"	1.500"	.750"	.750"	5/16-18	.450"	1.500"	.338 lb

Material Specifications

Material	Alloy*	Process	Finish
Aluminum	6105-T5	Milled	Anodize

* Or comparable

Included Hardware (Mount Nub to T-Slot)

Part No.	Series	Qty.	Bolt	T-Nut
3306	10	1	1/4-20 x 1" SHCS	Economy
3613	15	1	5/16-18 x 1.5" SHCS	Economy

Suggested Hardware (Mount Arm to Nub)

Part No.	Series	Qty.	Bolt
3342	10	2	1/4-20 x 1/2" FBHSCS
3330	15	2	5/16-18 x 11/16" FBHSCS

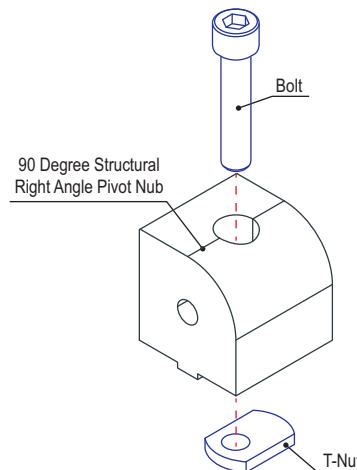

Universal Structural Right Angle Pivot Nub

Part Description:

The universal structural right angle pivot nub is an external fastening method commonly used as a connection hub to create a structural pivot ranging from 0-90 degrees either parallel or perpendicular to the mounting profile. The universal structural right angle pivot nub requires no machining services and can be easily assembled, lending itself to repositioning and reuse.

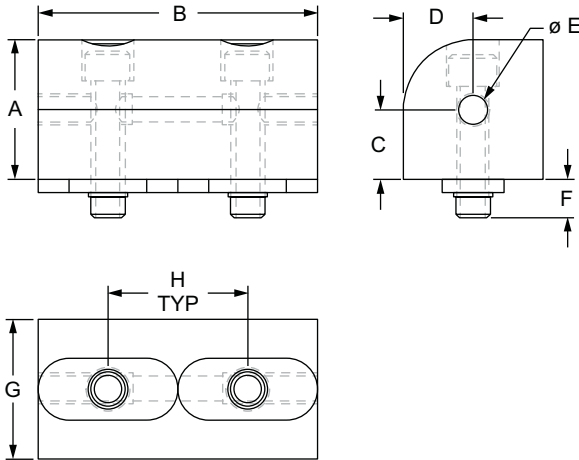

Part No.	Series	Color	A	B	C	D	E	F	G	H	Weight
4003	10	Clear	1.000"	2.000"	.500"	.500"	1/4-20	.275"	1.000"	1.000"	.214 lb
4003-Black	10	Black	1.000"	2.000"	.500"	.500"	1/4-20	.275"	1.000"	1.000"	.214 lb
4403	15	Clear	1.500"	3.000"	.750"	.750"	5/16-18	.450"	1.500"	1.500"	.685 lb
4403-Black	15	Black	1.500"	3.000"	.750"	.750"	5/16-18	.450"	1.500"	1.500"	.685 lb

Material Specifications

Material	Alloy*	Process	Finish
Aluminum	6105-T5	Milled	Anodize

* Or comparable

Included Hardware (Mount Nub to T-Slot)

Part No.	Series	Qty.	Bolt	T-Nut
3306	10	2	1/4-20 x 1" SHCS	Economy
3613	15	2	5/16-18 x 1.5" SHCS	Economy

Suggested Hardware (Mount Arm to Nub)

Part No.	Series	Qty.	Bolt
3342	10	2	1/4-20 x 1/2" FBHSCS
3330	15	2	5/16-18 x 11/16" FBHSCS

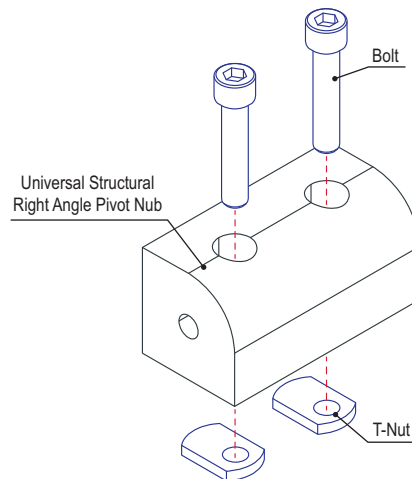



Part Description:

The “L” structural pivot arm is an external connection method that is typically used to create a structural angle on a perpendicular axis. This fastening option provides a long-lasting connection and requires no machining services. It can be easily assembled, lending itself to repositioning and reuse. **Tip:** Use double slide-in economy T-nuts (pg. 364) to save time and money. Pre-load your hardware prior to connecting profiles to simplify your assembly and save time.

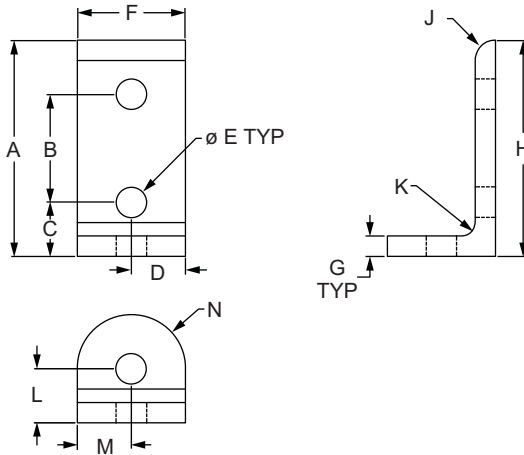

Part No.	Series	Color	A	B	C	D	E	F	G	H	J	K	L	M	N	Weight
4149	10	Clear	2.000"	1.000"	.500"	.500"	.281"	1.000"	.188"	2.000"	.188"	.125"	.500"	.500"	.505"	.044 lb
4149-Black	10	Black	2.000"	1.000"	.500"	.500"	.281"	1.000"	.188"	2.000"	.188"	.125"	.500"	.500"	.505"	.044 lb
4349	15	Clear	3.000"	1.500"	.750"	.750"	.328"	1.500"	.250"	3.000"	.250"	.312"	.750"	.750"	.755"	.142 lb
4349-Black	15	Black	3.000"	1.500"	.750"	.750"	.328"	1.500"	.250"	3.000"	.250"	.312"	.750"	.750"	.755"	.142 lb
25-4149	25	Clear	50.00mm	25.00mm	12.50mm	12.50mm	6.50mm	25.00mm	4.00mm	50.00mm	4.00mm	3.00mm	12.50mm	12.50mm	12.50mm	.0075 kg
25-4149-Black	25	Black	50.00mm	25.00mm	12.50mm	12.50mm	6.50mm	25.00mm	4.00mm	50.00mm	4.00mm	3.00mm	12.50mm	12.50mm	12.50mm	.0075 kg
40-4349	40	Clear	80.00mm	40.00mm	20.00mm	20.00mm	8.30mm	40.00mm	6.00mm	80.00mm	6.00mm	8.00mm	20.00mm	20.00mm	20.00mm	.0679 kg
40-4349-Black	40	Black	80.00mm	40.00mm	20.00mm	20.00mm	8.30mm	40.00mm	6.00mm	80.00mm	6.00mm	8.00mm	20.00mm	20.00mm	20.00mm	.0679 kg

Material Specifications

Material	Alloy*	Process	Finish
Aluminum	6105-T5	Milled	Anodize

* Or comparable

Suggested Hardware (Mount Arm to T-slot)

Part No.	Series	Qty.	Bolt	T-Nut
3393	10	3	1/4-20 x 1/2" BHSCS	Economy
3320	15	3	5/16-18 x 11/16" FBHSCS	Economy
75-3404	25	3	M6 x 10mm BHSCS	Economy
75-3422	40	3	M8 x 16mm BHSCS	Economy

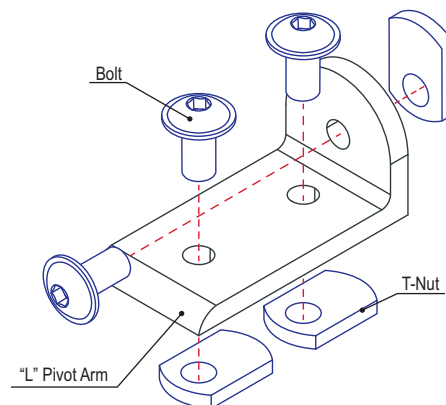

Standard Straight Structural Pivot Arm

Part Description:

The standard straight structural pivot arm is an external connection method that can be used either with a nub or mounted directly to the T-slot. It is typically used to create a structured angle connection between profiles. This fastening option provides a long-lasting connection and requires no machining services. It can be easily assembled, lending itself to repositioning and reuse. **Tip:** Use double slide-in economy T-nuts (pg. 364) to save time and money. Pre-load your hardware prior to connecting profiles to simplify your assembly and save time.

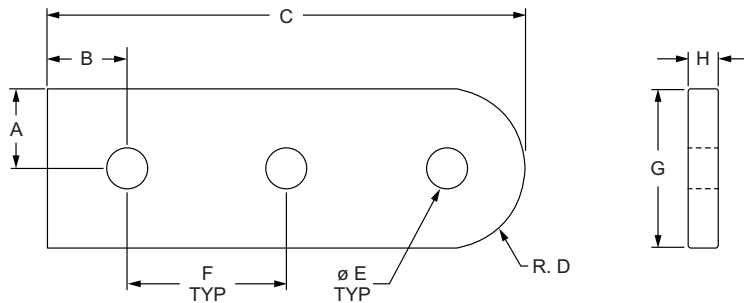

Part No.	Series	Color	A	B	C	D	E	F	G	H	Weight
4196	10	Clear	.500"	.500"	3.000"	.505"	.257"	1.000"	1.000"	.188"	.051 lb
4196-Black	10	Black	.500"	.500"	3.000"	.505"	.257"	1.000"	1.000"	.188"	.051 lb
4396	15	Clear	.745"	.750"	4.500"	.750"	.328"	1.500"	1.490"	.250"	.149 lb
4396-Black	15	Black	.745"	.750"	4.500"	.750"	.328"	1.500"	1.490"	.250"	.149 lb
25-4196	25	Clear	12.50mm	12.50mm	75.00mm	12.50mm	6.30mm	25.00mm	25.00mm	4.00mm	.0082 kg
25-4196-Black	25	Black	12.50mm	12.50mm	75.00mm	12.50mm	6.30mm	25.00mm	25.00mm	4.00mm	.0082 kg
40-4396	40	Clear	19.90mm	20.00mm	119.90mm	19.90mm	8.30mm	40.00mm	39.80mm	6.00mm	.0705 kg
40-4396-Black	40	Black	19.90mm	20.00mm	119.90mm	19.90mm	8.30mm	40.00mm	39.80mm	6.00mm	.0705 kg

Material Specifications

Material	Alloy*	Process	Finish
Aluminum	6105-T5	Milled	Anodize

* Or comparable

Suggested Hardware (Mount Arm to T-slot)

Part No.	Series	Qty.	Bolt	T-Nut
3321	10	3	1/4-20 x 1/2" FBHSCS	Economy
3320	15	3	5/16-18 x 11/16" FBHSCS	Economy
75-3404	25	3	M6 x 10mm BHSCS	Economy
75-3422	40	3	M8 x 16mm BHSCS	Economy

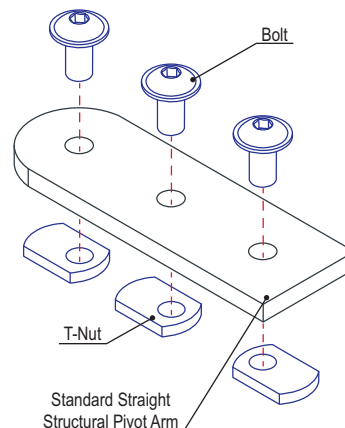



Part Description:

The extended straight structural pivot arm is an external connection method that can be used either with a nub or mounted directly to the T-slot. This part is typically used to create a structured angle connection between profiles while the extended arm provides a larger clearance area for pivot rotation. It provides a long-lasting connection, requires no machining services, and can be easily assembled, lending itself to repositioning and reuse. **Tip:** Use double slide-in economy T-nuts (pg. 364) to save time and money. Pre-load your hardware prior to connecting profiles to simplify your assembly and save time.

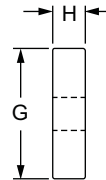
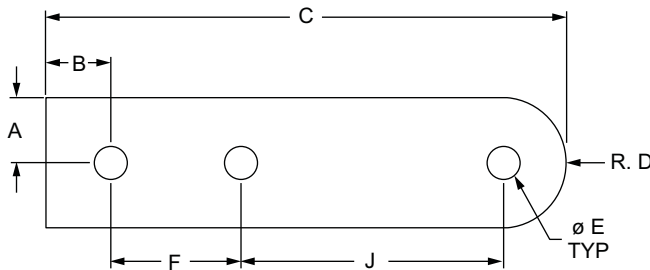

Part No.	Series	Color	A	B	C	D	E	F	G	H	J	Weight
4199	10	Clear	.500"	.500"	3.995"	.505"	.257"	1.000"	1.000"	.250"	2.010"	.092 lb
4199-Black	10	Black	.500"	.500"	3.995"	.505"	.257"	1.000"	1.000"	.250"	2.010"	.092 lb
4399	15	Clear	.745"	.750"	6.000"	.750"	.328"	1.500"	1.490"	.250"	3.000"	.203 lb
4399-Black	15	Black	.745"	.750"	6.000"	.750"	.328"	1.500"	1.490"	.250"	3.000"	.203 lb
25-4199	25	Clear	12.50mm	12.50mm	100.00mm	12.50mm	6.30mm	25.00mm	25.00mm	6.00mm	50.00mm	.0400 kg
25-4199-Black	25	Black	12.50mm	12.50mm	100.00mm	12.50mm	6.30mm	25.00mm	25.00mm	6.00mm	50.00mm	.0400 kg
40-4399	40	Clear	19.90mm	20.00mm	160.00mm	20.00mm	8.30mm	40.00mm	39.80mm	6.00mm	80.00mm	.0958 kg
40-4399-Black	40	Black	19.90mm	20.00mm	160.00mm	20.00mm	8.30mm	40.00mm	39.80mm	6.00mm	80.00mm	.0958 kg

Material Specifications

Material	Alloy*	Process	Finish
Aluminum	6105-T5	Milled	Anodize

* Or comparable

Suggested Hardware (Mount Arm to T-slot)

Part No.	Series	Qty.	Bolt	T-Nut
3321	10	3	1/4-20 x 1/2" FBHSCS	Economy
3320	15	3	5/16-18 x 11/16" FBHSCS	Economy
75-3404	25	3	M6 x 10mm BHSCS	Economy
75-3422	40	3	M8 x 16mm BHSCS	Economy

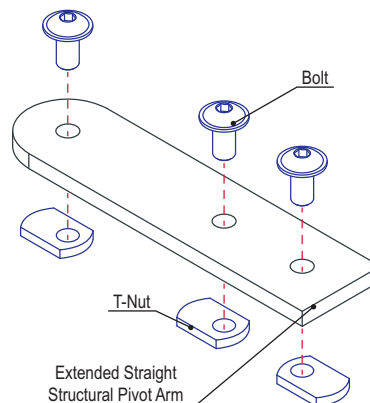

Standard Structural Pivot Assembly with Dual Straight Arms

Part Description:

The standard structural pivot assembly with dual straight arms comes preassembled with the pivot arms connected to the nub and includes the hardware to connect the nub to the mounting profile. It consists of one 0 degree, 90 degree or universal structural pivot nub and two straight structural pivot arms.

0 Degree Standard Structural Pivot

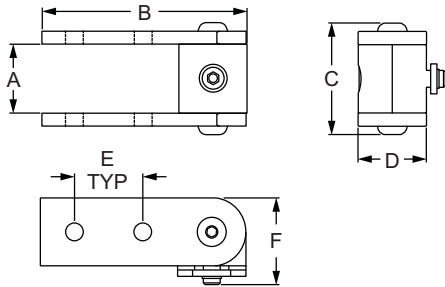

Part No.	Series	Color	Nub (Qty.)	Arm (Qty.)	A	B	C	D	E	F	Weight
4197	10	Clear	4187 (1)	4196 (2)	1.000"	3.010"	1.630"	1.000"	1.000"	1.275"	.163 lb
4197-Black	10	Black	4187 (1)	4196 (2)	1.000"	3.010"	1.630"	1.000"	1.000"	1.275"	.163 lb
4397	15	Clear	4387 (1)	4396 (2)	1.500"	4.500"	2.318"	1.500"	1.500"	1.945"	.663 lb
4397-Black	15	Black	4387 (1)	4396 (2)	1.500"	4.500"	2.318"	1.500"	1.500"	1.945"	.663 lb
25-4197	25	Clear	25-4187 (1)	25-4196 (2)	25.00mm	75.00mm	39.30mm	25.00mm	25.00mm	31.88mm	.0869 kg
25-4197-Black	25	Black	25-4187 (1)	25-4196 (2)	25.00mm	75.00mm	39.30mm	25.00mm	25.00mm	31.88mm	.0869 kg
40-4397	40	Clear	40-4387 (1)	40-4396 (2)	40.00mm	120.00mm	60.45mm	40.00mm	40.00mm	51.33mm	.3271 kg
40-4397-Black	40	Black	40-4387 (1)	40-4396 (2)	40.00mm	120.00mm	60.45mm	40.00mm	40.00mm	51.33mm	.3271 kg

90 Degree Standard Structural Pivot

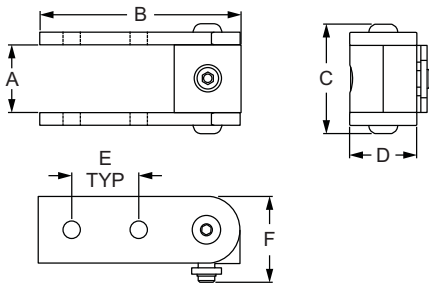

Part No.	Series	Color	Nub (Qty.)	Arm (Qty.)	A	B	C	D	E	F	Weight
4198	10	Clear	4188 (1)	4196 (2)	1.000"	3.010"	1.630"	1.000"	1.000"	1.275"	.164 lb
4198-Black	10	Black	4188 (1)	4196 (2)	1.000"	3.010"	1.630"	1.000"	1.000"	1.275"	.164 lb
4398	15	Clear	4388 (1)	4396 (2)	1.500"	4.500"	2.318"	1.500"	1.500"	1.945"	.476 lb
4398-Black	15	Black	4388 (1)	4396 (2)	1.500"	4.500"	2.318"	1.500"	1.500"	1.945"	.476 lb
25-4198	25	Clear	25-4188 (1)	25-4196 (2)	25.00mm	75.00mm	39.30mm	25.00mm	25.00mm	31.88mm	.0872 kg
25-4198-Black	25	Black	25-4188 (1)	25-4196 (2)	25.00mm	75.00mm	39.30mm	25.00mm	25.00mm	31.88mm	.0872 kg
40-4398	40	Clear	40-4388 (1)	40-4396 (2)	40.00mm	120.00mm	60.45mm	40.00mm	40.00mm	51.33mm	.2968 kg
40-4398-Black	40	Black	40-4388 (1)	40-4396 (2)	40.00mm	120.00mm	60.45mm	40.00mm	40.00mm	51.33mm	.2968 kg

CONTINUE



Standard Structural Pivot Assembly with Dual Straight Arms (Continued)

Universal Standard Structural Pivot

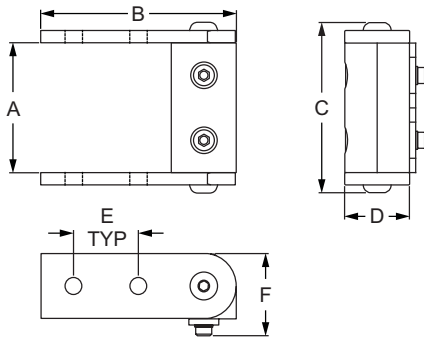

Part No.	Series	Color	Nub (Qty.)	Arm (Qty.)	A	B	C	D	E	F	Weight
4195	10	Clear	4186 (1)	4196 (2)	2.000"	3.010"	2.630"	1.275"	1.000"	1.275"	.288 lb
4195-Black	10	Black	4186 (1)	4196 (2)	2.000"	3.010"	2.630"	1.275"	1.000"	1.275"	.288 lb
4395	15	Clear	4386 (1)	4396 (2)	3.000"	4.500"	3.313"	1.945"	1.500"	1.945"	1.118 lb
4395-Black	15	Black	4386 (1)	4396 (2)	3.000"	4.500"	3.313"	1.945"	1.500"	1.945"	1.118 lb
25-4195	25	Clear	25-4186 (1)	25-4196 (2)	50.00mm	75.00mm	64.30mm	31.88mm	25.00mm	31.88mm	.1298 kg
25-4195-Black	25	Black	25-4186 (1)	25-4196 (2)	50.00mm	75.00mm	64.30mm	31.88mm	25.00mm	31.88mm	.1298 kg
40-4395	40	Clear	40-4386 (1)	40-4396 (2)	80.00mm	120.00mm	85.45mm	51.33mm	40.00mm	51.33mm	.3479 kg
40-4395-Black	40	Black	40-4386 (1)	40-4396 (2)	80.00mm	120.00mm	85.45mm	51.33mm	40.00mm	51.33mm	.3479 kg

Material Specifications

Material	Alloy*	Process	Finish
Aluminum	6105-T5	Milled	Anodize

* Or comparable

Included Hardware (Mount Arm to Nub)

Part No.	Series	Qty.	Bolt	T-Nut
3342	10	2	1/4-20 x 1/2" FBHSCS	—
3330	15	2	5/16-18 x 5/8" FBHSCS	—
13-6312	25	2	M6 x 12mm BHSCS	—
13-8316	40	2	M8 x 16mm BHSCS	—

Included Hardware (Mount Nub to T-Slot)

Part No.	Series	Qty.	Bolt	T-Nut
3306	10	1 or 2	1/4-20 x 1" SHCS	Economy
3613	15	1 or 2	5/16-18 x 1.5" SHCS	Economy
75-3415	25	1 or 2	M6 x 25mm SHCS	Economy
75-3479	40	1 or 2	M8 x 40mm SHCS	Economy

Suggested Hardware (Mount Arm to T-Slot)

Part No.	Series	Qty.	Bolt	T-Nut
3393	10	4	1/4-20 x 1/2" BHSCS	Economy
3320	15	4	5/16-18 x 11/16" FBHSCS	Economy
75-3404	25	4	M6 x 10mm BHSCS	Economy
75-3422	40	4	M8 x 16mm BHSCS	Economy

0 Degree Standard Structural Pivot

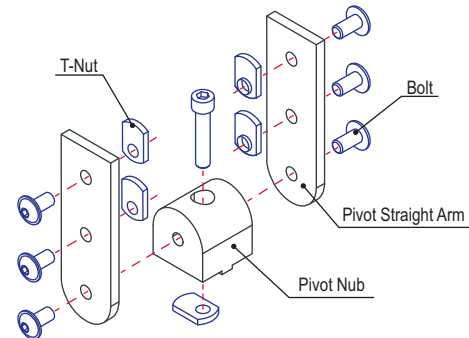

Universal Standard Structural Pivot

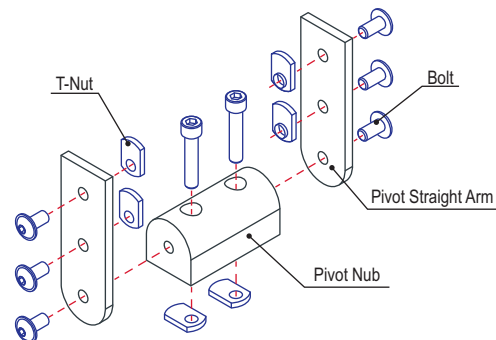

Standard Structural Pivot Assembly with Dual “L” Arms

Part Description:

The standard structural pivot assembly with dual “L” arms comes preassembled with the pivot arms connected to the nub and includes the hardware to connect the nub to the mounting profile. It consists of one 0 degree, 90 degree or universal structural pivot nub and two “L” structural pivot arms.

0 Degree Standard Structural Pivot

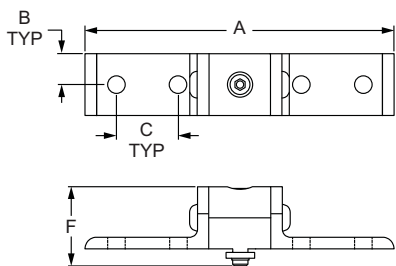

Part No.	Series	Color	Nub (Qty.)	Arm (Qty.)	A	B	C	D	E	F	Weight
4153	10	Clear	4187 (1)	4149 (2)	5.000"	.500"	1.000"	1.000"	1.000"	1.275"	.208 lb
4153-Black	10	Black	4187 (1)	4149 (2)	5.000"	.500"	1.000"	1.000"	1.000"	1.275"	.208 lb
4353	15	Clear	4387 (1)	4349 (2)	7.500"	.750"	1.500"	1.500"	1.500"	1.945"	.651 lb
4353-Black	15	Black	4387 (1)	4349 (2)	7.500"	.750"	1.500"	1.500"	1.500"	1.945"	.651 lb
25-4153	25	Clear	25-4187 (1)	25-4149 (2)	125.00mm	12.50mm	25.00mm	25.00mm	25.00mm	31.88mm	.0843 kg
25-4153-Black	25	Black	25-4187 (1)	25-4149 (2)	125.00mm	12.50mm	25.00mm	25.00mm	25.00mm	31.88mm	.0843 kg
40-4353	40	Clear	40-4387 (1)	40-4349 (2)	200.00mm	20.00mm	40.00mm	40.00mm	40.00mm	51.33mm	.3221 kg
40-4353-Black	40	Black	40-4387 (1)	40-4349 (2)	200.00mm	20.00mm	40.00mm	40.00mm	40.00mm	51.33mm	.3221 kg

90 Degree Standard Structural Pivot

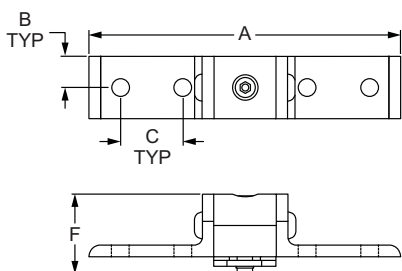

Part No.	Series	Color	Nub (Qty.)	Arm (Qty.)	A	B	C	D	E	F	Weight
4154	10	Clear	4188 (1)	4149 (2)	5.000"	.500"	1.000"	1.000"	1.000"	1.275"	.209 lb
4154-Black	10	Black	4188 (1)	4149 (2)	5.000"	.500"	1.000"	1.000"	1.000"	1.275"	.209 lb
4354	15	Clear	4388 (1)	4349 (2)	7.500"	.750"	1.500"	1.500"	1.500"	1.945"	.654 lb
4354-Black	15	Black	4388 (1)	4349 (2)	7.500"	.750"	1.500"	1.500"	1.500"	1.945"	.654 lb
25-4154	25	Clear	25-4188 (1)	25-4149 (2)	125.00mm	12.50mm	25.00mm	25.00mm	25.00mm	31.88mm	.0843 kg
25-4154-Black	25	Black	25-4188 (1)	25-4149 (2)	125.00mm	12.50mm	25.00mm	25.00mm	25.00mm	31.88mm	.0843 kg
40-4354	40	Clear	40-4388 (1)	40-4349 (2)	200.00mm	20.00mm	40.00mm	40.00mm	40.00mm	51.33mm	.3212 kg
40-4354-Black	40	Black	40-4388 (1)	40-4349 (2)	200.00mm	20.00mm	40.00mm	40.00mm	40.00mm	51.33mm	.3212 kg

CONTINUE



Standard Structural Pivot Assembly with Dual "L" Arms (Continued)

Universal Standard Structural Pivot

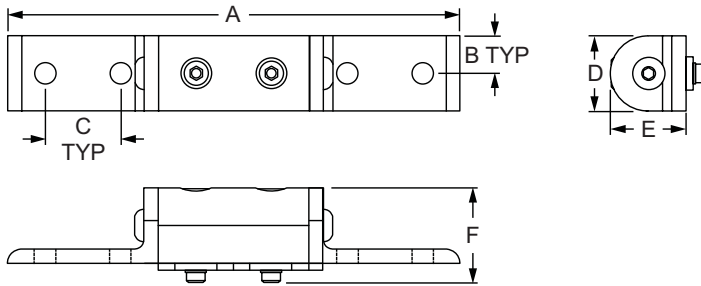

Part No.	Series	Color	Nub (Qty.)	Arm (Qty.)	A	B	C	D	E	F	Weight
4156	10	Clear	4186 (1)	4149 (2)	6.000"	.500"	1.000"	1.000"	1.000"	1.275"	.311 lb
4156-Black	10	Black	4186 (1)	4149 (2)	6.000"	.500"	1.000"	1.000"	1.000"	1.275"	.311 lb
4356	15	Clear	4386 (1)	4349 (2)	9.000"	.750"	1.500"	1.500"	1.500"	1.945"	.972 lb
4356-Black	15	Black	4386 (1)	4349 (2)	9.000"	.750"	1.500"	1.500"	1.500"	1.945"	.972 lb
25-4156	25	Clear	25-4186 (1)	25-4149 (2)	150.00mm	12.50mm	25.00mm	25.00mm	25.00mm	31.88mm	.1268 kg
25-4156-Black	25	Black	25-4186 (1)	25-4149 (2)	150.00mm	12.50mm	25.00mm	25.00mm	25.00mm	31.88mm	.1268 kg
40-4356	40	Clear	40-4386 (1)	40-4349 (2)	240.00mm	20.00mm	40.00mm	40.00mm	40.00mm	51.33mm	.4938 kg
40-4356-Black	40	Black	40-4386 (1)	40-4349 (2)	240.00mm	20.00mm	40.00mm	40.00mm	40.00mm	51.33mm	.4938 kg

Material Specifications

Material	Alloy*	Process	Finish
Aluminum	6105-T5	Milled	Anodize

* Or comparable

Included Hardware (Mount Arm to Nub)

Part No.	Series	Qty.	Bolt	T-Nut
3342	10	2	1/4-20 x 1/2" FBHSCS	—
3330	15	2	5/16-18 x 5/8" FBHSCS	—
13-6312	25	2	M6 x 12mm BHSCS	—
13-8316	40	2	M8 x 16mm BHSCS	—

Included Hardware (Mount Nub to T-Slot)

Part No.	Series	Qty.	Bolt	T-Nut
3306	10	1 or 2	1/4-20 x 1" SHCS	Economy
3613	15	1 or 2	5/16-18 x 1.5" SHCS	Economy
75-3415	25	1 or 2	M6 x 25mm SHCS	Economy
75-3479	40	1 or 2	M8 x 40mm SHCS	Economy

Suggested Hardware (Mount Arm to T-Slot)

Part No.	Series	Qty.	Bolt	T-Nut
3393	10	4	1/4-20 x 1/2" BHSCS	Economy
3320	15	4	5/16-18 x 11/16" FBHSCS	Economy
75-3404	25	4	M6 x 10mm BHSCS	Economy
75-3422	40	4	M8 x 16mm BHSCS	Economy

0 Degree Standard Structural Pivot

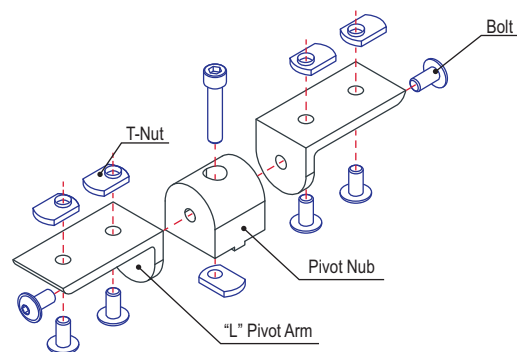

Universal Standard Structural Pivot

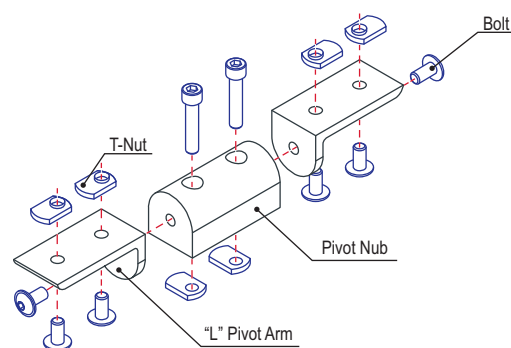

Standard Structural Pivot Assembly with Straight and "L" Arm

Part Description:

The standard structural pivot assembly with straight and "L" arm comes preassembled with the pivot arms connected to the nub and includes the hardware to connect the nub to the mounting profile. It consists of one 0 degree, 90 degree or universal structural pivot nub, one standard straight structural pivot arm and one "L" structural pivot arm.

0 Degree Standard Structural Pivot

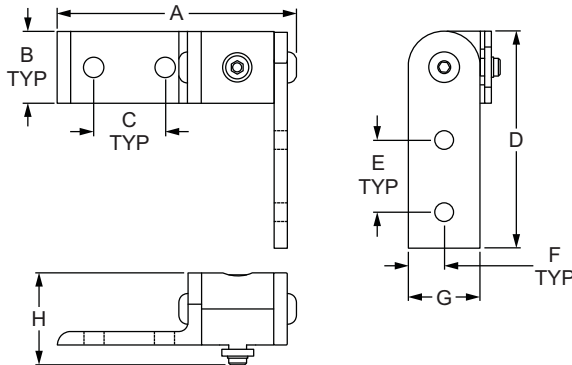

Part No.	Series	Color	Nub (Qty.)	Arm (Qty.)	A	B	C	D	E	F	G	H	Weight
4157	10	Clear	4187 (1)	4196 (1), 4149 (1)	3.315"	.500"	1.000"	3.010"	1.000"	.500"	1.000"	1.275"	.164 lb
4157-Black	10	Black	4187 (1)	4196 (1), 4149 (1)	3.315"	.500"	1.000"	3.010"	1.000"	.500"	1.000"	1.275"	.164 lb
4357	15	Clear	4387 (1)	4396 (1), 4349 (1)	4.909"	.750"	1.500"	4.500"	1.500"	.745"	1.495"	1.900"	.507 lb
4357-Black	15	Black	4387 (1)	4396 (1), 4349 (1)	4.909"	.750"	1.500"	4.500"	1.500"	.745"	1.495"	1.900"	.507 lb

90 Degree Standard Structural Pivot

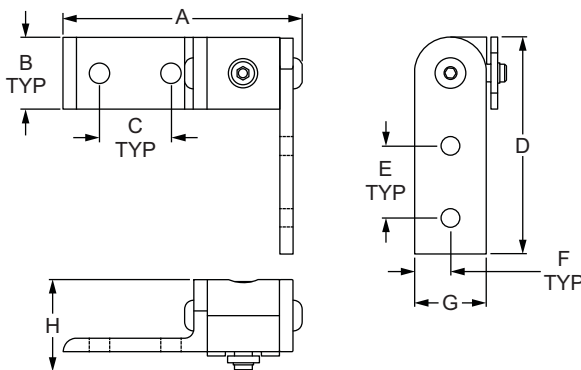

Part No.	Series	Color	Nub (Qty.)	Arm (Qty.)	A	B	C	D	E	F	G	H	Weight
4158	10	Clear	4188 (1)	4196 (1), 4149 (1)	3.315"	.500"	1.000"	3.010"	1.000"	.500"	1.000"	1.275"	.163 lb
4158-Black	10	Black	4188 (1)	4196 (1), 4149 (1)	3.315"	.500"	1.000"	3.010"	1.000"	.500"	1.000"	1.275"	.163 lb
4358	15	Clear	4388 (1)	4396 (1), 4349 (1)	6.409"	.750"	1.500"	4.500"	1.500"	.745"	1.495"	1.900"	.505 lb
4358-Black	15	Black	4388 (1)	4396 (1), 4349 (1)	6.409"	.750"	1.500"	4.500"	1.500"	.745"	1.495"	1.900"	.505 lb

CONTINUE



Standard Structural Pivot Assembly with Straight and "L" Arm (Continued)

Universal Standard Structural Pivot

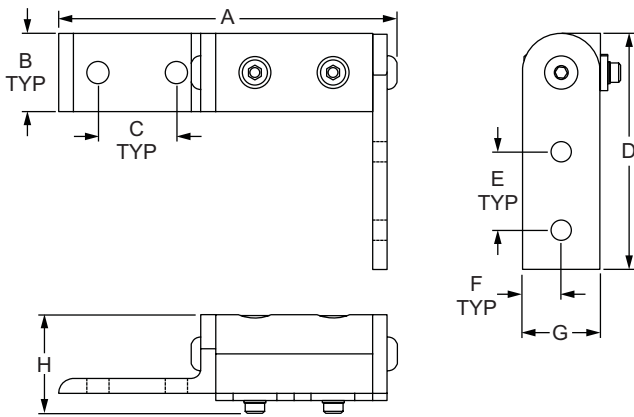

Part No.	Series	Color	Nub (Qty.)	Arm (Qty.)	A	B	C	D	E	F	G	H	Weight
4159	10	Clear	4186 (1)	4196 (1), 4149 (1)	4.315"	.500"	1.000"	3.010"	1.000"	.500"	1.000"	1.257"	.317 lb
4159-Black	10	Black	4186 (1)	4196 (1), 4149 (1)	4.315"	.500"	1.000"	3.010"	1.000"	.500"	1.000"	1.257"	.317 lb
4359	15	Clear	4386 (1)	4396 (1), 4349 (1)	6.409"	.750"	1.500"	4.500"	1.500"	.745"	1.495"	1.900"	.986 lb
4359-Black	15	Black	4386 (1)	4396 (1), 4349 (1)	6.409"	.750"	1.500"	4.500"	1.500"	.745"	1.495"	1.900"	.986 lb

Material Specifications

Material	Alloy*	Process	Finish
Aluminum	6105-T5	Milled	Anodize

* Or comparable

Suggested Hardware (Mount Arm to T-Slot)

Part No.	Series	Qty.	Bolt	T-Nut
3393	10	4	1/4-20 x 1/2" BHSCS	Economy
3320	15	4	5/16-18 x 11/16" FBHSCS	Economy

Included Hardware (Mount Arm to Nub)

Part No.	Series	Qty.	Bolt	T-Nut
3342	10	2	1/4-20 x 1/2" FBHSCS	—
3330	15	2	5/16-18 x 5/8" FBHSCS	—

Included Hardware (Mount Nub to T-Slot)

Part No.	Series	Qty.	Bolt	T-Nut
3306	10	1 or 2	1/4-20 x 1" SHCS	Economy
3613	15	1 or 2	5/16-18 x 1.5" SHCS	Economy

0 Degree Standard Structural Pivot

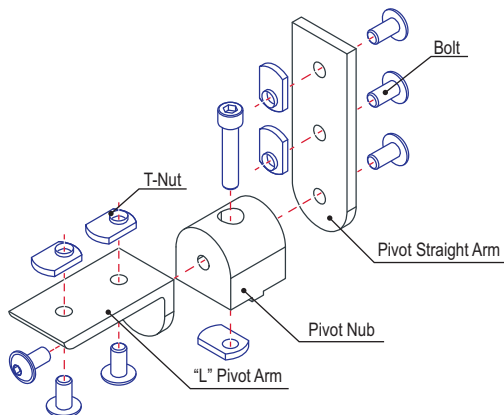

Universal Standard Structural Pivot

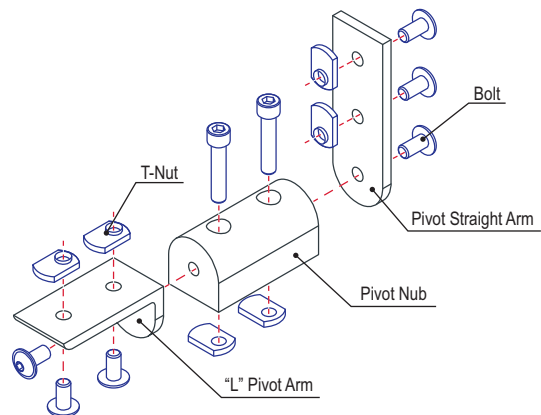

Right Angle Structural Pivot Assembly with Dual Straight Arms

Part Description:

The right angle structural pivot assembly with dual straight arms comes preassembled with the pivot arms connected to the nub and includes the hardware to connect the nub to the mounting profile. It consists of one 0 degree, 90 degree or universal right angle pivot nub and two straight structural pivot arms.

0 Degree Right Angle Structural Pivot

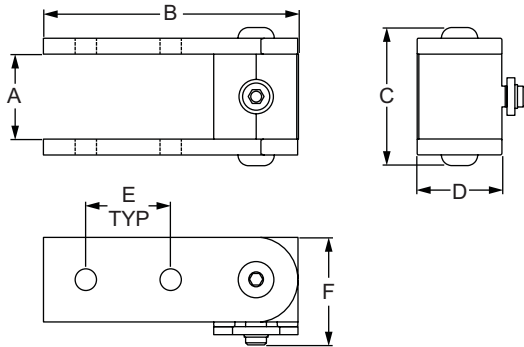

Part No.	Series	Color	Nub (Qty.)	Arm (Qty.)	A	B	C	D	E	F	Weight
4004	10	Clear	4001 (1)	4196 (2)	1.000"	3.010"	1.630"	1.000"	1.000"	1.275"	.226 lb
4004-Black	10	Black	4001 (1)	4196 (2)	1.000"	3.010"	1.630"	1.000"	1.000"	1.275"	.226 lb
4404	15	Clear	4401 (1)	4396 (2)	1.500"	4.500"	2.318"	1.500"	1.500"	1.950"	.683 lb
4404-Black	15	Black	4401 (1)	4396 (2)	1.500"	4.500"	2.318"	1.500"	1.500"	1.950"	.683 lb

90 Degree Right Angle Structural Pivot

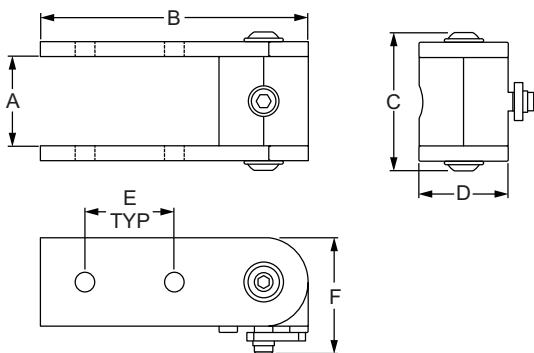

Part No.	Series	Color	Nub (Qty.)	Arm (Qty.)	A	B	C	D	E	F	Weight
4005	10	Clear	4002 (1)	4196 (2)	1.000"	3.010"	1.630"	1.000"	1.000"	1.275"	.225 lb
4005-Black	10	Black	4002 (1)	4196 (2)	1.000"	3.010"	1.630"	1.000"	1.000"	1.275"	.225 lb
4405	15	Clear	4402 (1)	4396 (2)	1.500"	4.500"	2.318"	1.500"	1.500"	1.945"	.688 lb
4405-Black	15	Black	4402 (1)	4396 (2)	1.500"	4.500"	2.318"	1.500"	1.500"	1.945"	.688 lb

CONTINUE



Right Angle Structural Pivot Assembly with Dual Straight Arms (Continued)

Universal Right Angle Structural Pivot

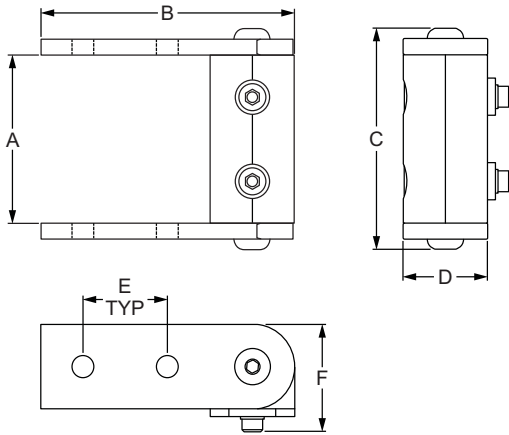

Part No.	Series	Color	Nub (Qty.)	Arm (Qty.)	A	B	C	D	E	F	Weight
4006	10	Clear	4003 (1)	4196 (2)	2.000"	3.010"	2.630"	1.000"	1.000"	1.280"	.322 lb
4006-Black	10	Black	4003 (1)	4196 (2)	2.000"	3.010"	2.630"	1.000"	1.000"	1.280"	.322 lb
4406	15	Clear	4403 (1)	4396 (2)	3.000"	4.500"	3.818"	1.500"	1.500"	1.945"	1.002 lb
4406-Black	15	Black	4403 (1)	4396 (2)	3.000"	4.500"	3.818"	1.500"	1.500"	1.945"	1.002 lb

Material Specifications

Material	Alloy*	Process	Finish
Aluminum	6105-T5	Milled	Anodize

* Or comparable

Suggested Hardware (Mount Arm to T-Slot)

Part No.	Series	Qty.	Bolt	T-Nut
3393	10	4	1/4-20 x 1/2" BHSCS	Economy
3320	15	4	5/16-18 x 11/16" FBHSCS	Economy

Included Hardware (Mount Arm to Nub)

Part No.	Series	Qty.	Bolt	T-Nut
3342	10	2	1/4-20 x 1/2" FBHSCS	—
3330	15	2	5/16-18 x 5/8" FBHSCS	—

Included Hardware (Mount Nub to T-Slot)

Part No.	Series	Qty.	Bolt	T-Nut
3306	10	1 or 2	1/4-20 x 1" SHCS	Economy
3613	15	1 or 2	5/16-18 x 1.5" SHCS	Economy

90 Degree Right Angle Structural Pivot

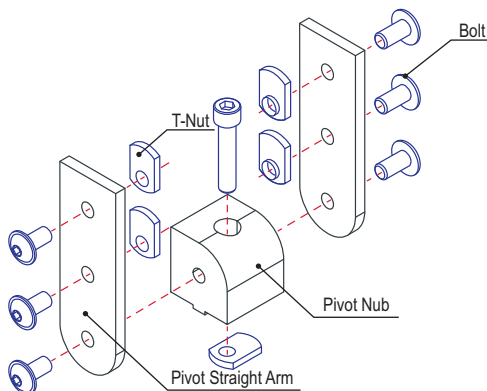

Universal Right Angle Structural Pivot

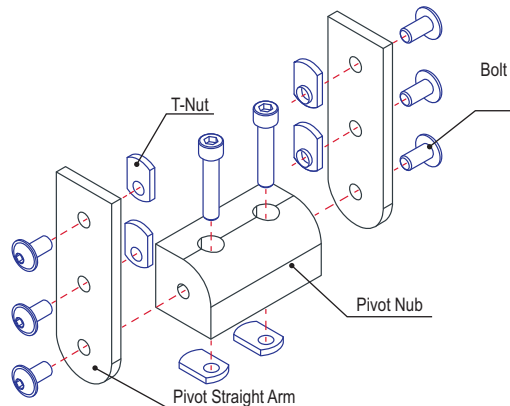

Right Angle Structural Pivot Assembly with Dual "L" Arms

Part Description:

The right angle structural pivot assembly with dual "L" arms comes preassembled with the pivot arms connected to the nub and includes the hardware to connect the nub to the mounting profile. It consists of one 0 degree, 90 degree or universal structural right angle pivot nub and two "L" structural pivot arms.

0 Degree Right Angle Structural Pivot

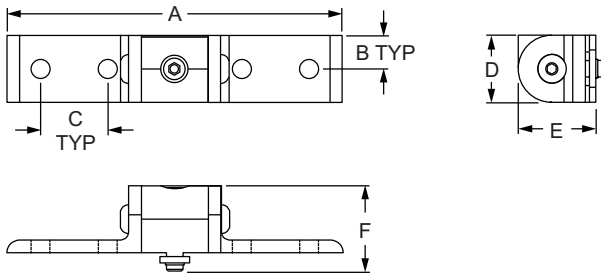

Part No.	Series	Color	Nub (Qty.)	Arm (Qty.)	A	B	C	D	E	F	Weight
4007	10	Clear	4001 (1)	4149 (2)	5.000"	.500"	1.000"	1.000"	1.000"	1.275"	.213 lb
4007-Black	10	Black	4001 (1)	4149 (2)	5.000"	.500"	1.000"	1.000"	1.000"	1.275"	.213 lb
4407	15	Clear	4401 (1)	4349 (2)	7.500"	.750"	1.500"	1.500"	1.500"	1.945"	.662 lb
4407-Black	15	Black	4401 (1)	4349 (2)	7.500"	.750"	1.500"	1.500"	1.500"	1.945"	.662 lb

90 Degree Right Angle Structural Pivot

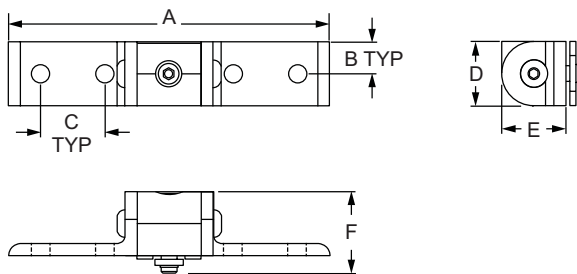

Part No.	Series	Color	Nub (Qty.)	Arm (Qty.)	A	B	C	D	E	F	Weight
4008	10	Clear	4002 (1)	4149 (2)	5.000"	.500"	1.000"	1.000"	1.000"	1.275"	.213 lb
4008-Black	10	Black	4002 (1)	4149 (2)	5.000"	.500"	1.000"	1.000"	1.000"	1.275"	.213 lb
4408	15	Clear	4402 (1)	4349 (2)	7.500"	.750"	1.500"	1.500"	1.500"	1.945"	.657 lb
4408-Black	15	Black	4402 (1)	4349 (2)	7.500"	.750"	1.500"	1.500"	1.500"	1.945"	.657 lb

CONTINUE



Right Angle Structural Pivot Assembly with Dual "L" Arms (Continued)

Universal Right Angle Structural Pivot

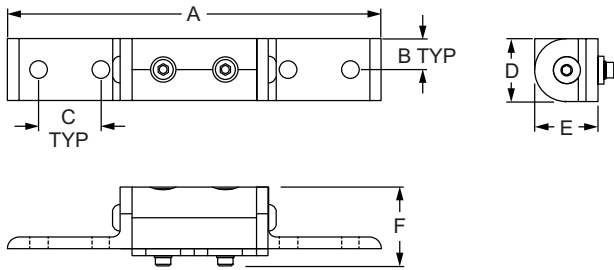

Part No.	Series	Color	Nub (Qty.)	Arm (Qty.)	A	B	C	D	E	F	Weight
4009	10	Clear	4003 (1)	4149 (2)	6.000"	.500"	1.000"	1.000"	1.000"	1.275"	.319 lb
4009-Black	10	Black	4003 (1)	4149 (2)	6.000"	.500"	1.000"	1.000"	1.000"	1.275"	.319 lb
4409	15	Clear	4403 (1)	4349 (2)	9.000"	.750"	1.500"	1.500"	1.500"	1.945"	1.013 lb
4409-Black	15	Black	4403 (1)	4349 (2)	9.000"	.750"	1.500"	1.500"	1.500"	1.945"	1.013 lb

Material Specifications

Material	Alloy*	Process	Finish
Aluminum	6105-T5	Milled	Anodize

* Or comparable

Suggested Hardware (Mount Arm to T-Slot)

Part No.	Series	Qty.	Bolt	T-Nut
3393	10	4	1/4-20 x 1/2" BHSCS	Economy
3320	15	4	5/16-18 x 11/16" FBHSCS	Economy

Included Hardware (Mount Arm to Nub)

Part No.	Series	Qty.	Bolt	T-Nut
3342	10	2	1/4-20 x 1/2" FBHSCS	—
3330	15	2	5/16-18 x 5/8" FBHSCS	—

Included Hardware (Mount Nub to T-Slot)

Part No.	Series	Qty.	Bolt	T-Nut
3306	10	1 or 2	1/4-20 x 1" SHCS	Economy
3613	15	1 or 2	5/16-18 x 1.5" SHCS	Economy

90 Degree Right Angle Structural Pivot

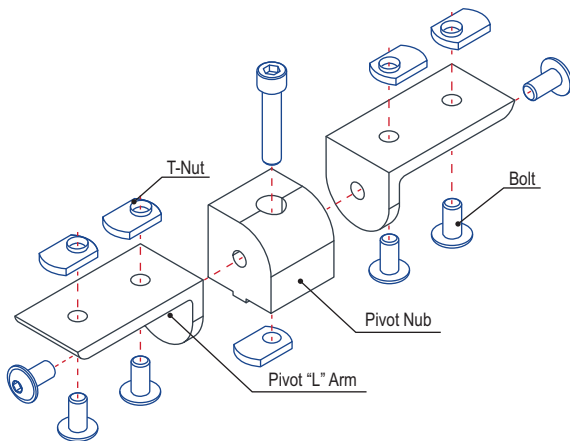

Universal Right Angle Structural Pivot

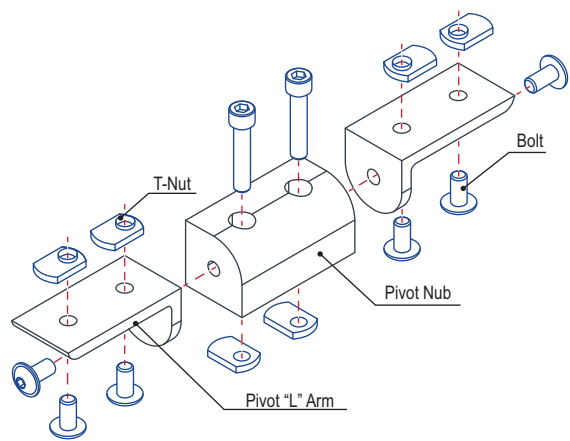

Slide-In Economy T-Nut - Centered Thread

Part Description:

The slide-in economy T-nut with centered thread is a cost-effective fastening method available with options in size, material, thread, and finish. It loads from the profile ends and has a pilot thread projection that adds additional threading for increased strength. The centered thread of the slide-in economy T-nut lends itself to connections towards the middle of a profile or with a flat plate. This T-nut is available in a double (pg. 364) or triple (pg. 365) configuration. For information on 80/20 screw and bolt offerings for the slide-in economy T-nut refer to pages beginning on 385. **Tip:** Position the pilot projection down in the T-slot to avoid an uneven connection or crashing.



Style #1



Style #2

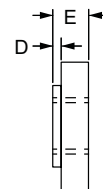
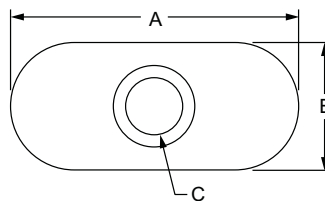
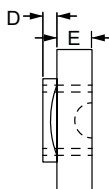
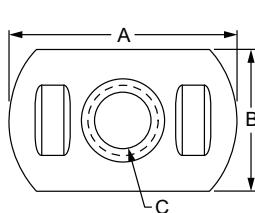

Part No.	Series	Style	Material	Grade	Finish	A	B	C (Thread)	D	E	Weight
3275	10	Style 2	Steel	1010	Black Zinc	.875"	.443"	8-32	.030"	.124"	.008 lb
3276	10	Style 2	Steel	1010	Black Zinc	.875"	.443"	10-32	.030"	.124"	.008 lb
3675	10	Style 2	Stainless-Steel	18-8	Stainless	1.000"	.443"	1/4-20	.030"	.124"	.010 lb
3382	10	Style 2	Steel	1010	Black Zinc	1.000"	.443"	1/4-20	.030"	.124"	.009 lb
3785	10	Style 2	Steel	1010	Bright Zinc	1.000"	.443"	1/4-20	.030"	.124"	.010 lb
3859	10	Style 2	Steel	1010	Bright Zinc	1.000"	.443"	M6 x 1.0	.030"	.124"	.010 lb
3686	15	Style 1	Stainless-Steel	304 Stainless	Stainless	.812"	.505"	1/4-20	.050"	.125"	.013 lb
3286	15	Style 1	Steel	1010	Black Zinc	.812"	.505"	1/4-20	.050"	.125"	.009 lb
3786	15	Style 1	Steel	1010	Bright Zinc	.812"	.505"	1/4-20	.050"	.125"	.012 lb
3789	15	Style 1	Steel	1010	Bright Zinc	.984"	.505"	5/16-18	.078"	.133"	.015 lb
3836	15	Style 2	Steel	1010	Bright Zinc	1.125"	.505"	M6 x 1.0	.050"	.130"	.018 lb
25-3382	25	Style 2	Steel	1010	Black Zinc	25.40mm	11.25mm	1/4-20	.76mm	3.15mm	.0041 kg
25-1961	25	Style 2	Steel	1010	Bright Zinc	25.40mm	11.25mm	M6 x 1.0	.76mm	3.15mm	.0041 kg
30-3789	30	Style 1	Steel	1010	Bright Zinc	25.40mm	12.60mm	5/16-18	2.00mm	3.60mm	.0068 kg
30-3796	30	Style 1	Steel	1010	Bright Zinc	25.40mm	12.60mm	M8 x 1.25	2.00mm	3.60mm	.0053 kg
40-3286	40	Style 1	Steel	1010	Black Zinc	20.62mm	12.83mm	1/4-20	1.27mm	4.45mm	.0054 kg
40-1961	40	Style 2	Steel	1010	Bright Zinc	28.58mm	12.83mm	M6 x 1.0	1.27mm	4.45mm	.0079 kg

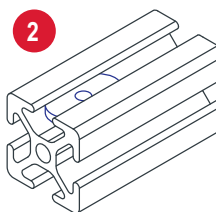
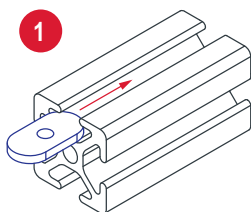

Part Description:

The slide-in economy T-nut with offset thread is a cost-effective fastening method available with options in size, material, and finish. It loads from the profile ends and has a pilot thread projection that adds additional threading for increased strength. The offset thread of the slide-in economy T-nut creates clean connections, making it ideal for corner connections because the T-nut doesn't extend beyond the length of the profile. This T-nut is available in a double (pg. 364) or triple (pg. 365) configuration. For information on 80/20 screw and bolt offerings for the slide-in economy T-nut with offset thread refer to pages beginning on 385. **Tip:** Position the pilot projection down in the T-slot to avoid an uneven connection or crashing.



Style #1

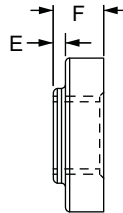
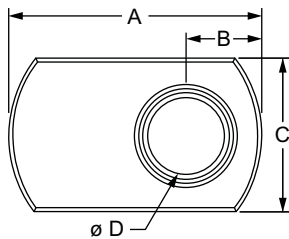

Style #2

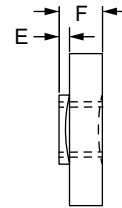
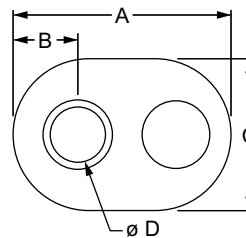

Part No.	Series	Style	Material	Grade	Finish	A	B	C	D (Thread)	E	F	Weight
3676	10	Style 1	Stainless-Steel	304 Stainless	Stainless	.625"	.187"	.380"	10-32	.030"	.124"	.005 lb
3278	15	Style 1	Steel	1010	Black Zinc	.984"	.281"	.638"	5/16-18	.080"	.222"	.020 lb
3778	15	Style 1	Steel	1010	Bright Zinc	.984"	.281"	.638"	5/16-18	.080"	.222"	.020 lb
3838	15	Style 1	Steel	1010	Bright Zinc	.984"	.281"	.638"	M8 X 1.25	.080"	.222"	.020 lb
3678	15	Style 1	Stainless-Steel	304 Stainless	Stainless	1.113"	.281"	.638"	5/16-18	.080"	.222"	.027 lb
25-1941	25	Style 2	Steel	1010	Bright Zinc	15.87mm	4.75mm	11.00mm	M4 x 0.7	.76mm	3.14mm	.0027 kg
25-1951	25	Style 2	Steel	1010	Bright Zinc	15.87mm	4.75mm	11.00mm	M5 x 0.8	.76mm	3.14mm	.0024 kg
30-1961	30	Style 1	Steel	1010	Bright Zinc	20.60mm	5.00mm	13.00mm	M6 x 1.0	1.27mm	4.44mm	.0056 kg
40-1981	40	Style 1	Steel	1010	Bright Zinc	24.99mm	7.14mm	16.19mm	M8 x 1.25	2.03mm	5.64mm	.0092 kg
40-3278	40	Style 1	Steel	1010	Black Zinc	24.99mm	7.14mm	16.19mm	5/16-18	2.03mm	5.64mm	.0090 kg

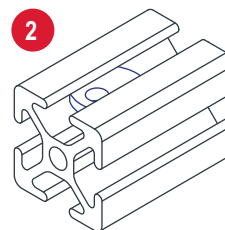
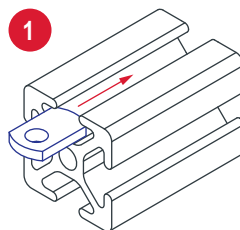

Double Slide-In Economy T-Nut

Part Description:

The double slide-in economy T-nut is a fastening option that saves time and simplifies the assembly process. It loads from the profile ends and is available with options in size and finish. The pilot projection adds additional threading for increased strength. There is also a triple slide-in economy T-nut available (page 365). For information on 80/20 screw and bolt offerings for the double slide-in economy T-nut refer to pages beginning on 385. **Tip:** Position the pilot projection down in the T-slot to avoid an uneven connection or crashing.

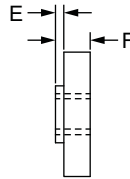
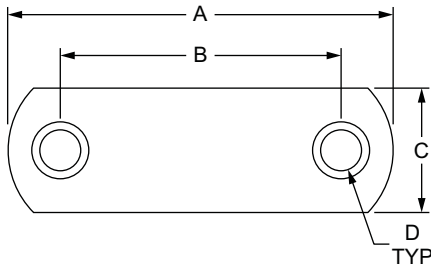

Part No.	Series	Material	Grade	Finish	A	B	C	D (Thread)	E	F	Weight
3281	10	Steel	1010	Black Zinc	1.375"	1.000"	.443"	8-32	.030"	.124"	.015 lb
3280	10			Black Zinc	1.875"	1.000"	.443"	1/4-20	.050"	.144"	.019 lb
3800	10			Bright Zinc	1.875"	1.000"	.443"	M6 x 1.0	.050"	.144"	.020 lb
3279	15			Black Zinc	2.813"	1.500"	.638"	5/16-18	.080"	.222"	.061 lb
3879	15			Bright Zinc	3.000"	1.500"	.638"	M8 x 1.25	.080"	.222"	.067 lb
25-1962	25			Bright Zinc	47.60mm	25.00mm	11.20mm	M6 x 1.0	1.27mm	3.68mm	.0093 kg
40-1982	40			Bright Zinc	75.00mm	40.00mm	16.20mm	M8 x 1.25	2.00mm	5.60mm	.0293 kg

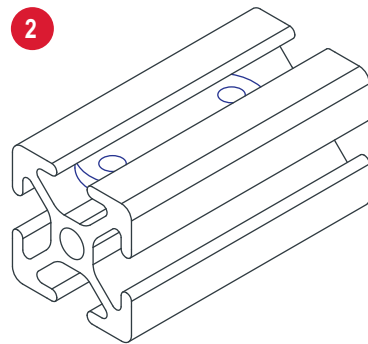
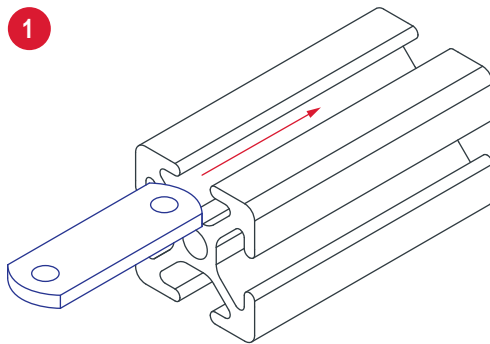

80/20[®] Triple Slide-In Economy T-Nut / Economy T-Nut Holding Spring**Part Description:**

The triple slide-in economy T-nut is a fastening option that saves time and simplifies the assembly process. It is especially useful for multiple-hole flat plates. This fastener loads from the profile ends and is available with options in size and finish. The pilot thread projection adds additional threading for increased strength. For information on 80/20 screw and bolt offerings for the triple slide-in economy T-nut refer to pages beginning on 385. **Tip:** Position the pilot projection down in the T-slot to avoid an uneven connection or crashing.

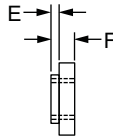
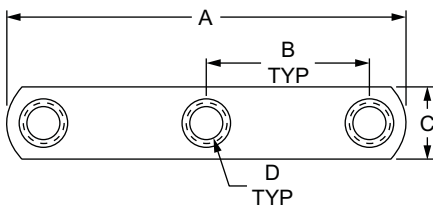

Part No.	Series	Material	Grade	Finish	A	B	C	D (Thread)	E	F	Weight
3287	10	Steel	1010	Black Zinc	2.450"	1.000"	.443"	1/4-20	.050"	.144"	.025 lb
3900	10			Bright Zinc	2.450"	1.000"	.443"	M6 x 1.0	.050"	.144"	.034 lb
3285	15			Black Zinc	3.562"	1.500"	.638"	5/16-18	.080"	.222"	.077 lb
3805	15			Bright Zinc	3.562"	1.500"	.638"	M8 x 1.25	.080"	.222"	.080 lb

Economy T-Nut Holding Spring

The economy T-nut holding spring, available in 15 and 40 series, snaps onto the pilot projection of the 15 and 40 series Style 1 economy T-nut (page 362), double economy slide-in T-nut (page 364), and triple economy slide in T-nut (page 365). The spring holds the fastener in place, even when the profile is in a vertical position.

Additional Information: Please note that springs are sold in packs of 100.

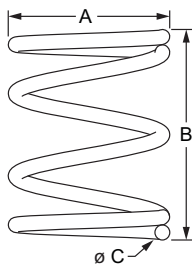

Part No.	Series	Material	Grade	A	B	C	Weight
3010	15 40	Steel	1215	.240"	.313"	.022"	.022 lb

Standard Slide-In T-Nut

Part Description:

The standard slide-in T-nut is a fastening option that loads from the profile ends. It is a strong, durable connection that is available with options in size, thread, and finish. It can be customized up to 36" (91.44cm). For information on 80/20 screw and bolt offerings for the standard slide-in T-nut refer to pages beginning on 385.

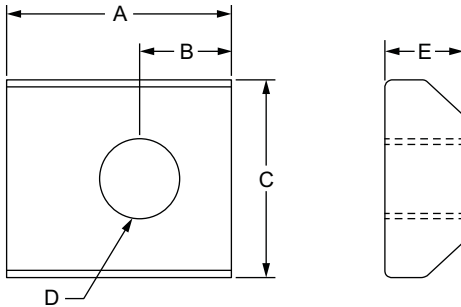

10 Series Standard Slide-In T-Nut

Part No.	Series	Type	Material	Grade	Finish	A	B	C	D (Thread)	E	Weight
3205	10	Standard T-Nut	Steel	1215	Black Zinc	.490"	.200"	.431"	10-32	.171"	.008 lb
3705	10	Standard T-Nut			Bright Zinc	.490"	.200"	.431"	10-32	.171"	.007 lb
3204	10	Standard T-Nut			Black Zinc	.490"	.200"	.431"	1/4-20	.171"	.007 lb
3206	10	Standard T-Nut			Black Zinc	.490"	.200"	.431"	M5 x 0.8	.171"	.008 lb
3871	10	Standard T-Nut			Bright Zinc	.490"	.200"	.431"	M5 x 0.8	.171"	.008 lb
3873	10	Standard T-Nut			Bright Zinc	.490"	.200"	.431"	M6 x 1.0	.171"	.007 lb
8901	10	Custom T-Nut			Mill	Per Your Drawing	Per Your Drawing	.431"	Per Your Drawing	.171"	.019 lb / in.
8901-36	10	T-Nut Profile			Mill	36.000"	Per Your Drawing	.431"	Per Your Drawing	.171"	.684 lb
8901-145	10	T-Nut Profile			Mill	145.000"	Per Your Drawing	.431"	Per Your Drawing	.171"	2.755 lb

15 Series Standard Slide-In T-Nut

Part No.	Series	Type	Material	Grade	Finish	A	B	C	D (Thread)	E	Weight
3201	15	Standard T-Nut	Steel	1215	Black Zinc	.700"	.281"	.625"	10-32	.243"	.025 lb
3202	15	Standard T-Nut			Black Zinc	.700"	.281"	.625"	1/4-20	.243"	.024 lb
3203	15	Standard T-Nut			Black Zinc	.700"	.281"	.625"	5/16-18	.243"	.022 lb
3866	15	Standard T-Nut			Bright Zinc	.700"	.281"	.625"	M6 x 1.0	.243"	.025 lb
3703	15	Standard T-Nut			Bright Zinc	.700"	.281"	.625"	5/16-18	.243"	.022 lb
3868	15	Standard T-Nut			Bright Zinc	.700"	.281"	.625"	M8 x 1.25	.243"	.022 lb
8900	15	Custom T-Nut			Mill	Per Your Drawing	Per Your Drawing	.625"	Per Your Drawing	.243"	.040 lb / in.
8900-36	15	T-Nut Profile			Mill	36.000"	Per Your Drawing	.625"	Per Your Drawing	.243"	1.440 lb
8900-145	15	T-Nut Profile			Mill	145.000"	Per Your Drawing	.625"	Per Your Drawing	.243"	5.800 lb

CONTINUE

25 Series Standard Slide-In T-Nut

Part No.	Series	Type	Material	Grade	Finish	A	B	C	D (Thread)	E	Weight
25-3206	25	Standard T-Nut	Steel	1215	Bright Zinc	12.45mm	5.08mm	10.95mm	M5 x 0.8	4.34mm	.0036 kg
25-1954	25	Standard T-Nut			Bright Zinc	12.45mm	5.08mm	10.95mm	M5 x 0.8	4.34mm	.0041 kg
25-1964	25	Standard T-Nut			Bright Zinc	12.45mm	5.08mm	10.95mm	M6 x 1.0	4.34mm	.0036 kg
25-3204	25	Standard T-Nut			Black Zinc	12.45mm	5.08mm	10.95mm	1/4-20	4.34mm	.0032 kg
25-8901	25	Custom T-Nut			Mill	Per Your Drawing	Per Your Drawing	10.95mm	Per Your Drawing	4.34mm	.0004 kg / mm
25-8901-914	25	T-Nut Profile			Mill	914.00mm	Per Your Drawing	10.95mm	Per Your Drawing	4.34mm	.2742 kg
25-8901-3683	25	T-Nut Profile			Mill	3683.00mm	Per Your Drawing	10.95mm	Per Your Drawing	4.34mm	1.1049 kg

40 Series Standard Slide-In T-Nut

Part No.	Series	Type	Material	Grade	Finish	A	B	C	D (Thread)	E	Weight
40-1964	40	Standard T-Nut	Steel	1215	Bright Zinc	17.45mm	7.14mm	15.88mm	M6 x 1.0	6.35mm	.0113 kg
40-1984	40	Standard T-Nut			Bright Zinc	17.45mm	7.14mm	15.88mm	M8 x 1.25	6.35mm	.0100 kg
40-3202	40	Standard T-Nut			Black Zinc	17.45mm	7.14mm	15.88mm	1/4-20	6.35mm	.0109 kg
40-3203	40	Standard T-Nut			Black Zinc	17.45mm	7.14mm	15.88mm	5/16-18	6.35mm	.0104 kg
40-8900	40	Custom T-Nut			Mill	Per Your Drawing	Per Your Drawing	15.88mm	Per Your Drawing	6.35mm	.0007 kg / mm
40-8900-914	40	T-Nut Profile			Mill	914.00mm	Per Your Drawing	15.88mm	Per Your Drawing	6.35mm	.6398 kg
40-8900-3683	40	T-Nut Profile			Mill	3683.00mm	Per Your Drawing	15.88mm	Per Your Drawing	6.35mm	2.5781 kg

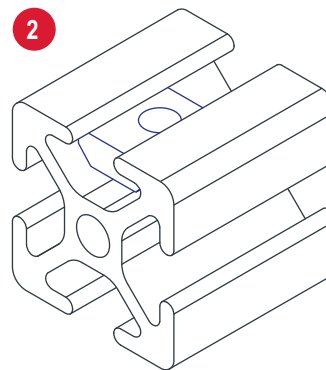
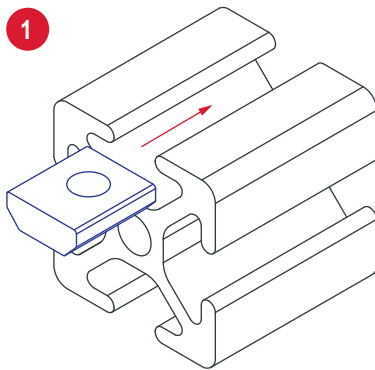

Self-Aligning Slide-In T-Nut with Ball Spring

80/20[®] Inc.

Part Description:

The self-aligning slide-in T-nut with ball spring is a fastening option that loads from the profile ends. The projection on the T-nut aligns it in the T-slot while the ball spring holds the fastener in place, even when the profile is in a vertical position. It is available with different thread options. For information on 80/20 screw and bolt offerings for the self-aligning slide-in T-nut with ball spring refer to pages beginning on 385.

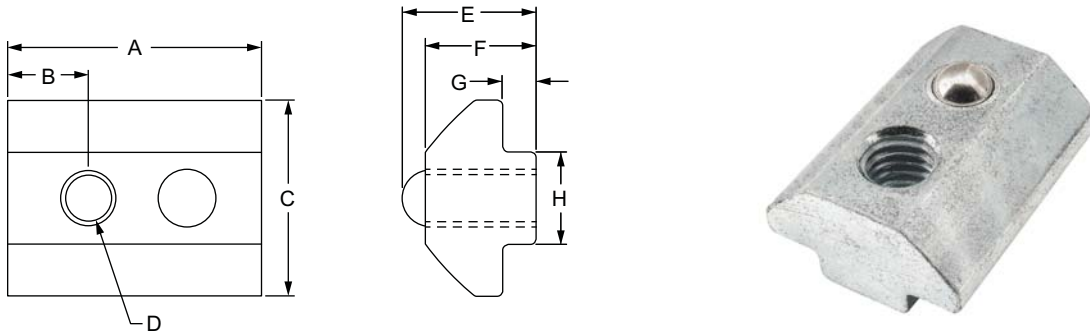

Part No.	Series	Material	Grade	Finish	A	B	C	D (Thread)	E	F	G	H	Weight
13050	15 40	Steel	1045	Bright Zinc	22.00mm	7.00mm	17.00mm	M4 x 0.7	11.60mm	9.60mm	2.90mm	8.00mm	.0181 kg
13051	15 40				22.00mm	7.00mm	17.00mm	M5 x 0.8	11.60mm	9.60mm	2.90mm	8.00mm	.0181 kg
13052	15 40				22.00mm	7.00mm	17.00mm	M6 x 1.0	11.60mm	9.60mm	2.90mm	8.00mm	.0172 kg
13053	15 40				22.00mm	7.00mm	17.00mm	M8 x 1.25	11.60mm	9.60mm	2.90mm	8.00mm	.0159 kg
13054	15 40				22.00mm	7.00mm	17.00mm	1/4-20	11.60mm	9.60mm	2.90mm	8.00mm	.0168 kg
13055	15 40				22.00mm	7.00mm	17.00mm	5/16-18	11.60mm	9.60mm	2.90mm	8.00mm	.0159 kg

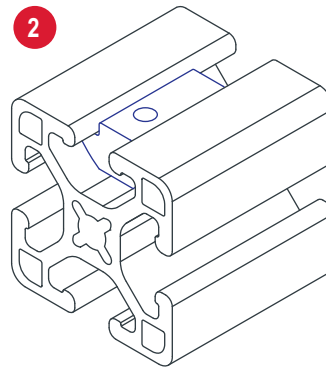
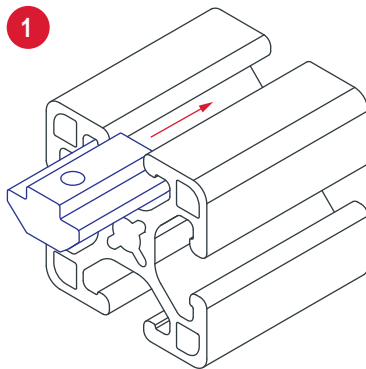

FASTENERS

Part Description:

The slide-in T-nut with ball spring is a fastening option that loads from the profile ends. The ball spring holds the T-nut in the T-slot, even when the profile is in a vertical position. It is available with different thread options. For information on 80/20 screw and bolt offerings for the slide-in T-nut with ball spring refer to pages beginning on 385.

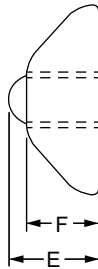
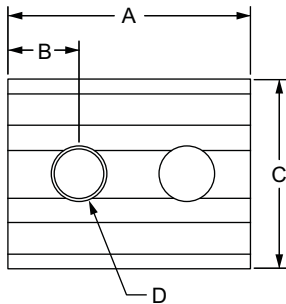

Part No.	Series	Material	Grade	Finish	A	B	C	D (Thread)	E	F	Weight
13064	15 40	Steel	1045	Bright Zinc	23.00mm	6.75mm	18.00mm	M5	8.50mm	6.80mm	.0150 kg
13065	15 40				23.00mm	6.75mm	18.00mm	M6	8.50mm	6.80mm	.0145 kg
13066	15 40				23.00mm	6.75mm	18.00mm	M8	8.50mm	6.80mm	.0132 kg

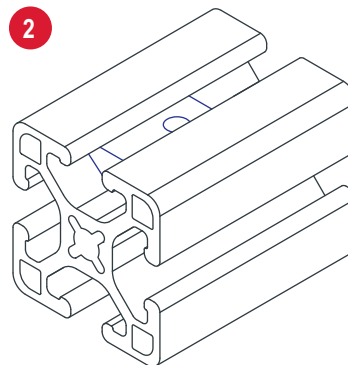
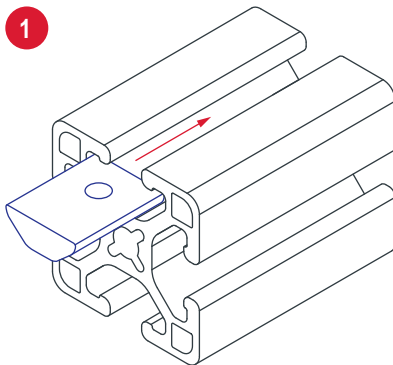

Self-Aligning Slide-In T-Nut

Part Description:

The self-aligning slide-in T-nut is a strong fastening option that loads from the profile ends. The projection on the T-nut aligns it in the T-slot for easy assembly. This fastener is available in a variety of sizes and threads. For information on 80/20 screw and bolt offerings for the self-aligning slide-in T-nut refer to pages beginning on 385.

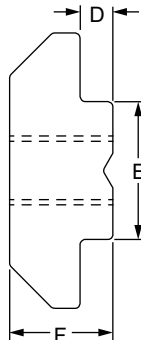
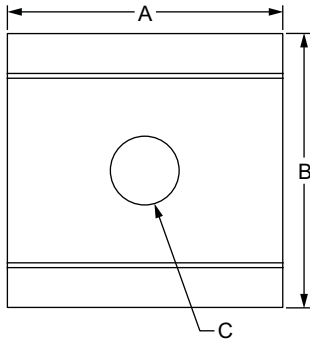

Part No.	Series	Material	Grade	Finish	A	B	C (Thread)	D	E	F	Weight
13022	15 30 40	Steel	1045	Bright Zinc	16.00mm	16.00mm	M4 x 0.7	1.80mm	7.80mm	6.00mm	.0082 kg
13023	15 30 40				16.00mm	16.00mm	M5 x 0.8	1.80mm	7.80mm	6.00mm	.0082 kg
13024	15 30 40				16.00mm	16.00mm	M6 x 1.0	1.80mm	7.80mm	6.00mm	.0077 kg
13025	15 30 40				16.00mm	16.00mm	M8 x 1.25	1.80mm	7.80mm	6.00mm	.0068 kg
13046	45				20.00mm	19.50mm	M4 x 0.7	5.10mm	9.80mm	10.60mm	.0214 kg
13047	45				20.00mm	19.50mm	M5 x 0.8	5.10mm	9.80mm	10.60mm	.0204 kg
13048	45				20.00mm	19.50mm	M6 x 1.0	5.10mm	9.80mm	10.60mm	.0200 kg
13049	45				20.00mm	19.50mm	M8 x 1.25	5.10mm	9.80mm	10.60mm	.0177 kg

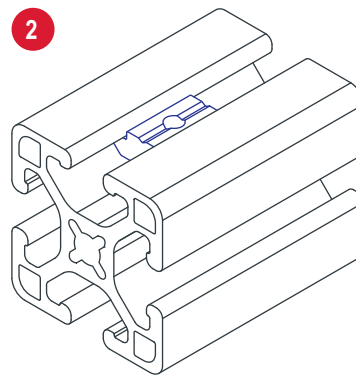
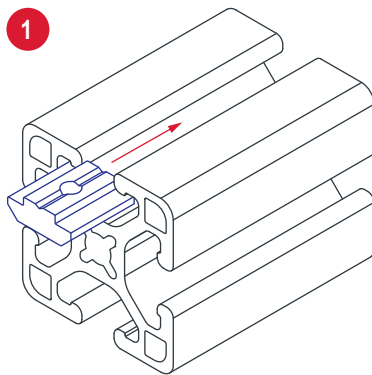

Part Description:

The slide-in economy T-nut block is a fastening option that loads from the profile ends. It is the most cost-effective slide-in T-nut and also provides infinite positioning along the profile T-slot. This fastener is available in a variety of sizes and threads. For information on 80/20 screw and bolt offerings for the slide-in economy T-nut block refer to pages beginning on 385.

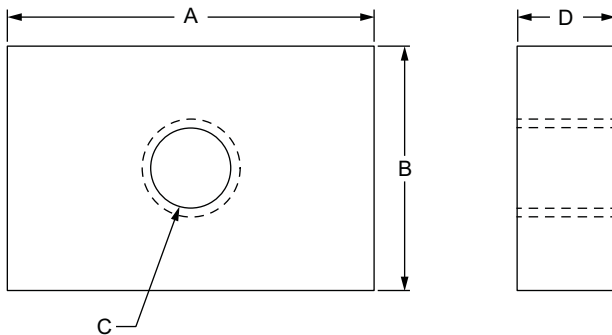

Part No.	Series	Material	Grade	Finish	Process	Color	A	B	C (Thread)	D	Weight
14124	10 25	Steel	ST50	Bright Zinc	Stamped	Silver	15.00mm	10.00mm	M6 x 1.0	4.00mm	.0036 kg
14126	15 40 45						19.00mm	16.00mm	M6 x 1.0	4.00mm	.0082 kg
14127	15 40 45						19.00mm	16.00mm	M8 x 1.25	4.00mm	.0073 kg
14130	15 40 45						20.00mm	13.00mm	M6 x 1.0	5.00mm	.0084 kg
14131	15 40 45						20.00mm	13.00mm	M8 x 1.25	5.00mm	.0082 kg
14159	20						9.00mm	9.00mm	M4 x 0.7	3.00mm	.0014 kg
14122	20						9.00mm	9.00mm	M5 x 0.8	3.00mm	.0014 kg
14125	45						15.00mm	10.00mm	M6 x 1.0	5.00mm	.0047 kg
14128	45						19.00mm	19.00mm	M6 x 1.0	4.00mm	.0099 kg
14129	45						19.00mm	19.00mm	M8 x 1.25	4.00mm	.0095 kg

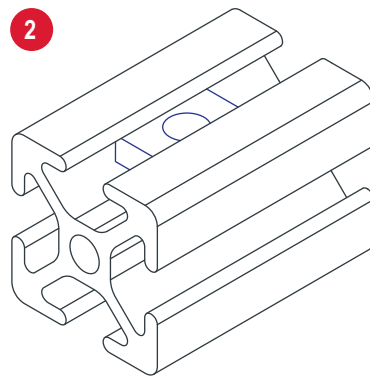
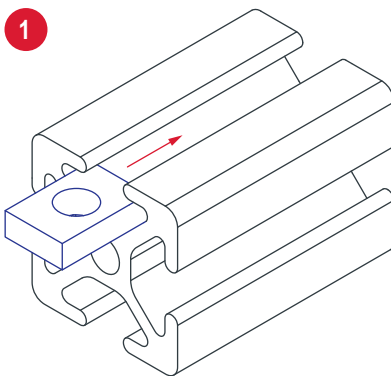

Roll-In T-Nut with Flex Handle

Part Description:

The roll-in T-nut with flex handle is a fastening option that loads from either the profile ends or side, which is helpful in applications where the ends are inaccessible. The flex handle sticks out past the profile to make it easy to position and move within the T-slot. It is available with options in size, material, thread, and finish. For information on 80/20 screw and bolt offerings for the roll-in T-nut with flex handle refer to pages beginning on 385.

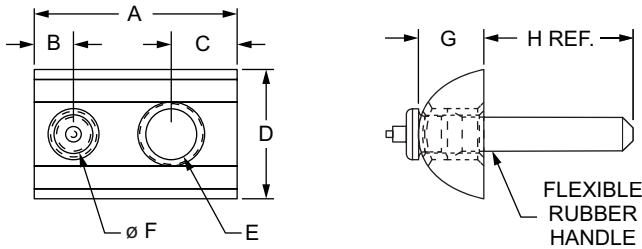

Part No.	Series	Material	Grade	Finish	A	B	C	D	E (Thread)	F	G	H	Weight
3375	10	Steel	1215	Black Zinc	.620"	.120"	.201"	.395"	10-32	.116"	.200"	.456"	.008 lb
3790	10	Steel	1215	Bright Zinc	.620"	.120"	.201"	.395"	10-32	.116"	.200"	.456"	.008 lb
3376	10	Steel	1215	Black Zinc	.620"	.120"	.201"	.395"	1/4-20	.116"	.200"	.456"	.008 lb
3624	10	Stainless-Steel	303 Stainless	Stainless	.620"	.120"	.201"	.395"	1/4-20	.116"	.200"	.456"	.008 lb
3791	10	Steel	1215	Bright Zinc	.620"	.120"	.201"	.395"	1/4-20	.116"	.200"	.456"	.008 lb
3875	10	Steel	1215	Bright Zinc	.620"	.120"	.201"	.395"	M5 x 0.8	.116"	.200"	.456"	.007 lb
3876	10	Steel	1215	Bright Zinc	.620"	.120"	.201"	.395"	M6 x 1.0	.116"	.200"	.456"	.008 lb
3284	15	Steel	1215	Black Zinc	.875"	.195"	.310"	.510"	10-32	.116"	.285"	.391"	.023 lb
3784	15	Steel	1215	Bright Zinc	.875"	.195"	.310"	.510"	10-32	.116"	.285"	.391"	.021 lb
3844	15	Steel	1215	Bright Zinc	.875"	.195"	.310"	.510"	M5 x 0.8	.116"	.285"	.391"	.025 lb
3283	15	Steel	1215	Black Zinc	.875"	.195"	.310"	.510"	1/4-20	.116"	.285"	.391"	.024 lb
3783	15	Steel	1215	Bright Zinc	.875"	.195"	.310"	.510"	1/4-20	.116"	.285"	.391"	.023 lb
3843	15	Steel	1215	Bright Zinc	.875"	.195"	.310"	.510"	M6 x 1.0	.116"	.285"	.391"	.023 lb
3282	15	Steel	1215	Black Zinc	.875"	.195"	.310"	.510"	5/16-18	.116"	.285"	.391"	.022 lb
3782	15	Steel	1215	Bright Zinc	.875"	.195"	.310"	.510"	5/16-18	.116"	.285"	.391"	.022 lb
3842	15	Steel	1215	Bright Zinc	.875"	.195"	.310"	.510"	M8 x 1.25	.116"	.285"	.391"	.022 lb
3602	15	Stainless-Steel	303 Stainless	Stainless	.875"	.195"	.310"	.510"	1/4-20	.116"	.285"	.391"	.023 lb
3600	15	Stainless-Steel	303 Stainless	Stainless	.875"	.195"	.310"	.510"	5/16-18	.116"	.285"	.391"	.021 lb
25-1956	25	Steel	1215	Bright Zinc	15.75mm	3.05mm	5.11mm	10.03mm	M5 x 0.8	2.95mm	5.08mm	11.58mm	.0041 kg
25-1966	25	Steel	1215	Bright Zinc	15.75mm	3.05mm	5.11mm	10.03mm	M6 x 1.0	2.95mm	5.08mm	11.58mm	.0036 kg
25-3376	25	Steel	1215	Black Zinc	15.75mm	3.05mm	5.11mm	10.03mm	1/4-20	2.95mm	5.08mm	11.58mm	.0036 kg
40-1966	40	Steel	1215	Bright Zinc	22.22mm	4.95mm	7.87mm	12.70mm	M6 x 1.0	2.95mm	7.24mm	9.93mm	.0104 kg
40-1986	40	Steel	1215	Bright Zinc	22.22mm	4.95mm	7.87mm	12.70mm	M8 x 1.25	2.95mm	7.24mm	9.93mm	.0118 kg
40-3282	40	Steel	1215	Black Zinc	22.22mm	4.95mm	7.87mm	12.70mm	5/16-18	2.95mm	7.24mm	9.93mm	.0100 kg
40-3283	40	Steel	1215	Black Zinc	22.22mm	4.95mm	7.87mm	12.70mm	1/4-20	2.95mm	7.24mm	9.93mm	.0109 kg

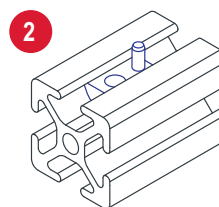
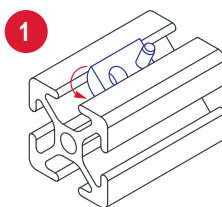

Part Description:

The roll-in T-nut with set screw is a fastening option that loads from either the profile ends or side, which is helpful in applications where the ends are inaccessible. When the set screw is engaged it keeps the T-nut in place in the T-slot, even if the profile is in a vertical position, simplifying the assembly process. It is available with options in size, material, thread, and finish. For information on 80/20 screw and bolt offerings for the roll-in T-nut with set screw refer to pages beginning on 385. **Tip:** An "L" wrench or combo tool (pg. 900-901) is required for adjusting the set screw.

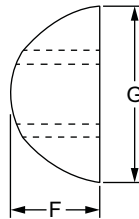
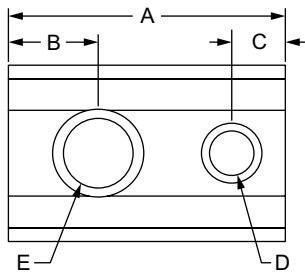

Part No.	Series	Material	Grade	Finish	A	B	C	D (Set Screw)	E (Thread)	F	G	Weight
3312	10	Steel	1215	Black Zinc	.620"	.201"	.120"	6-32	10-32	.200"	.395"	.009 lb
3313	10	Steel	1215	Black Zinc	.620"	.201"	.120"	6-32	1/4-20	.200"	.395"	.008 lb
3309	15	Steel	1215	Black Zinc	.875"	.310"	.195"	10-24	10-32	.285"	.510"	.024 lb
3310	15	Steel	1215	Black Zinc	.875"	.310"	.195"	10-24	1/4-20	.285"	.510"	.024 lb
3311	15	Steel	1215	Black Zinc	.875"	.310"	.195"	10-24	5/16-18	.285"	.510"	.020 lb
3605	15	Stainless-Steel	303 Stainless	Stainless	.875"	.310"	.195"	10-32	1/4-20	.285"	.510"	.023 lb
3608	15	Stainless-Steel	303 Stainless	Stainless	.875"	.310"	.195"	10-32	5/16-18	.285"	.510"	.021 lb
3781	15	Steel	1215	Bright Zinc	.875"	.310"	.195"	10-24	10-32	.285"	.510"	.023 lb
3787	15	Steel	1215	Bright Zinc	.875"	.310"	.195"	10-24	1/4-20	.285"	.510"	.024 lb
3788	15	Steel	1215	Bright Zinc	.875"	.310"	.195"	10-24	5/16-18	.285"	.510"	.020 lb
3892	15	Steel	1215	Bright Zinc	.875"	.310"	.195"	M5 x 0.8	M5 x 0.8	.285"	.510"	.023 lb
3894	15	Steel	1215	Bright Zinc	.875"	.310"	.195"	M5 x 0.8	M8 x 1.25	.285"	.510"	.020 lb
3898	15	Steel	1215	Bright Zinc	.310"	.875"	.195"	M5 x 0.8	M6 x 1.0	.285"	.510"	.023 lb
25-3312	25	Steel	1215	Black Zinc	15.75mm	5.11mm	3.05mm	6-32	10-32	5.08mm	10.03mm	.0041 kg
25-3313	25	Steel	1215	Black Zinc	15.75mm	5.11mm	3.05mm	6-32	1/4-20	5.08mm	10.03mm	.0036 kg
40-1968	40	Steel	1215	Bright Zinc	22.22mm	7.87mm	4.95mm	10-24	M6 x 1.0	7.24mm	12.95mm	.0109 kg
40-1988	40	Steel	1215	Bright Zinc	22.22mm	7.87mm	4.95mm	10-24	M8 x 1.25	7.24mm	12.95mm	.0095 kg
40-3310	40	Steel	1215	Black Zinc	22.22mm	7.87mm	4.95mm	10-24	1/4-20	7.24mm	12.95mm	.0104 kg
40-3311	40	Steel	1215	Black Zinc	22.22mm	7.87mm	4.95mm	10-24	5/16-18	7.24mm	12.95mm	.0100 kg

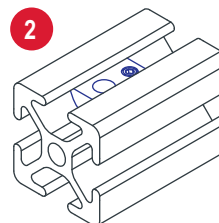
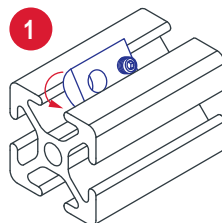

Roll-In T-Nut with Ball Spring

Part Description:

The roll-in T-nut with ball spring is a fastening option that loads from the profile ends or side, which is helpful for applications where the ends are inaccessible. The ball spring holds the T-nut in the T-slot, even when the profile is in a vertical position, simplifying the assembly process. It is available with options in size, material, thread, and finish. For information on 80/20 screw and bolt offerings for the roll-in T-nut with ball spring refer to pages beginning on 385.

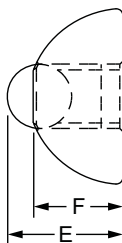
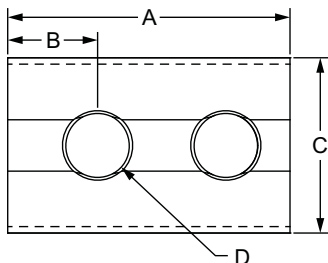

Part No.	Series	Material	Grade	Finish	A	B	C	D (Thread)	E	F	Weight
3919	10	Steel	1045	Bright Zinc	.630"	.213"	.386"	M4 x 0.7	.253"	.203"	.009 lb
3920	10	Steel	1045	Bright Zinc	.630"	.213"	.386"	M5 x 0.8	.253"	.203"	.009 lb
3921	10	Steel	1045	Bright Zinc	.630"	.213"	.386"	M6 x 1.0	.253"	.203"	.008 lb
3922	10	Steel	1045	Bright Zinc	.630"	.213"	.386"	10-32	.253"	.203"	.008 lb
3923	10	Steel	1045	Bright Zinc	.630"	.213"	.386"	1/4-20	.253"	.203"	.008 lb
3666	10	Stainless-Steel	304 Stainless	Stainless	.630"	.213"	.386"	M4 x 0.7	.253"	.203"	.008 lb
3667	10	Stainless-Steel	304 Stainless	Stainless	.630"	.213"	.386"	M5 x 0.8	.253"	.203"	.009 lb
3668	10	Stainless-Steel	304 Stainless	Stainless	.630"	.213"	.386"	M6 x 1.0	.253"	.203"	.008 lb
3669	10	Stainless-Steel	304 Stainless	Stainless	.630"	.213"	.386"	10-32	.253"	.203"	.009 lb
3670	10	Stainless-Steel	304 Stainless	Stainless	.630"	.213"	.386"	1/4-20	.253"	.203"	.009 lb
3913	15	Steel	1045	Bright Zinc	.866"	.234"	.539"	M5 x 0.8	.343"	.276"	.023 lb
3914	15	Steel	1045	Bright Zinc	.866"	.234"	.539"	M6 x 1.0	.343"	.276"	.022 lb
3915	15	Steel	1045	Bright Zinc	.866"	.234"	.539"	M8 x 1.25	.343"	.276"	.021 lb
3916	15	Steel	1045	Bright Zinc	.866"	.234"	.539"	1/4-20	.343"	.276"	.022 lb
3917	15	Steel	1045	Bright Zinc	.866"	.234"	.539"	5/16-18	.343"	.276"	.022 lb
13018	15 40	Stainless-Steel	304 Stainless	Stainless	22.00mm	6.50mm	13.70mm	1/4-20	8.70mm	7.00mm	.0095 kg
13021	15 40	Stainless-Steel	304 Stainless	Stainless	22.00mm	6.50mm	13.70mm	5/16-18	8.70mm	7.00mm	.0091 kg
40-3913	40	Steel	1045	Bright Zinc	22.00mm	5.90mm	13.70mm	M5 x 0.8	8.70mm	7.00mm	.0100 kg
40-3914	40	Steel	1045	Bright Zinc	22.00mm	5.90mm	13.70mm	M6 x 1.0	8.70mm	7.00mm	.0100 kg
40-3915	40	Steel	1045	Bright Zinc	22.00mm	5.90mm	13.70mm	M8 x 1.25	8.70mm	7.00mm	.0091 kg

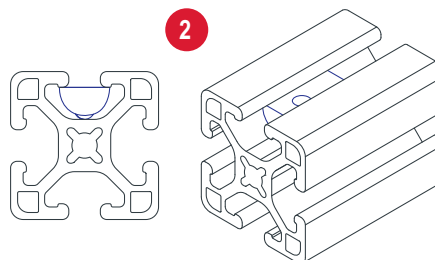
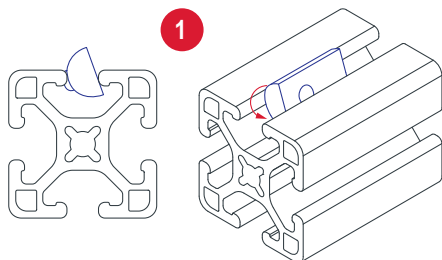

Part Description:

The self-aligning roll-in T-nut with ball spring is a fastening option that loads either from the profile ends or side, which is helpful for applications where the ends are inaccessible. The projection on the T-nut aligns it in the T-slot while the ball spring holds the fastener in place, even when the profile is in a vertical position. It is available with options in size, material, thread, and finish. For information on 80/20 screw and bolt offerings for the self-aligning roll-in T-nut with ball spring refer to pages beginning on 385.

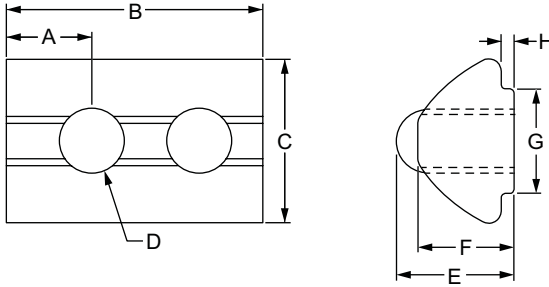

Part No.	Series	Material	Grade	Finish	A	B	C	D (Thread)	E	F	G	H	Weight
13082	20	Steel	1045	Bright Zinc	3.80mm	12.00mm	7.70mm	M3 x 0.5	5.50mm	4.50mm	5.00mm	0.60mm	.0018 kg
13083	20	Steel	1045	Bright Zinc	3.80mm	12.00mm	7.70mm	M4 x 0.7	5.50mm	4.50mm	5.00mm	0.60mm	.0018 kg
13084	20	Steel	1045	Bright Zinc	3.80mm	12.00mm	7.70mm	M5 x 0.8	5.50mm	4.50mm	5.00mm	0.60mm	.0018 kg
13027	15 40	Steel	1045	Bright Zinc	6.70mm	22.00mm	13.50mm	M4 x 0.7	8.90mm	7.20mm	7.80mm	0.80mm	.0109 kg
13028	15 40	Steel	1045	Bright Zinc	6.70mm	22.00mm	13.50mm	M5 x 0.8	8.90mm	7.20mm	7.80mm	0.80mm	.0104 kg
13031	15 40	Steel	1045	Bright Zinc	6.70mm	22.00mm	13.50mm	M6 x 1.0	8.90mm	7.20mm	7.80mm	0.80mm	.0100 kg
13034	15 40	Steel	1045	Bright Zinc	6.70mm	22.00mm	13.50mm	M8 x 1.25	8.90mm	7.20mm	7.80mm	0.80mm	.0086 kg
13039	15 40	Steel	1045	Bright Zinc	6.70mm	22.00mm	13.50mm	10-32	8.90mm	7.20mm	7.80mm	0.80mm	.0104 kg
13037	15 40	Steel	1045	Bright Zinc	6.70mm	22.00mm	13.50mm	1/4-20	8.90mm	7.20mm	7.80mm	0.80mm	.0099 kg
13040	15 40	Steel	1045	Bright Zinc	6.70mm	22.00mm	13.50mm	5/16-18	8.90mm	7.20mm	7.80mm	0.80mm	.0091 kg
13029	15 40	Stainless-Steel	304 Stainless	Stainless	6.70mm	22.00mm	13.50mm	M5 x 0.8	8.90mm	7.20mm	7.80mm	0.80mm	.0104 kg
13032	15 40	Stainless-Steel	304 Stainless	Stainless	6.70mm	22.00mm	13.50mm	M6 x 1.0	8.90mm	7.20mm	7.80mm	0.80mm	.0099 kg
13035	15 40	Stainless-Steel	304 Stainless	Stainless	6.70mm	22.00mm	13.50mm	M8 x 1.25	8.90mm	7.20mm	7.80mm	0.80mm	.0086 kg

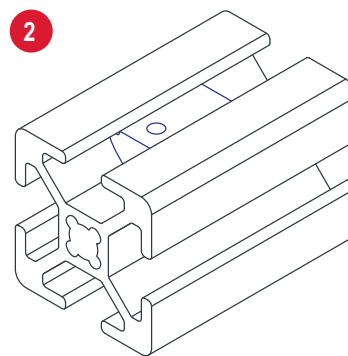
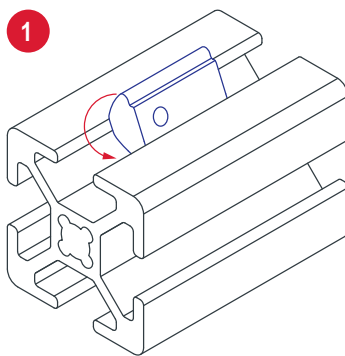

Self-Aligning Roll-In T-Nut

Part Description:

The self-aligning roll-in T-nut is a fastening option that loads either from the profile ends or side, which is helpful for applications where the ends are inaccessible. The projection on the T-nut aligns it in the T-slot for easy assembly. This fastening option provides infinite positioning along the T-slot and is available with options in size and thread. For information on 80/20 screw and bolt offerings for the self-aligning roll-in T-nut refer to pages beginning on 385.

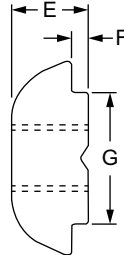
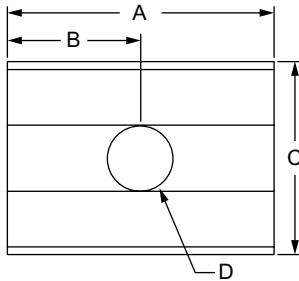

Part No.	Series	Material	Grade	Finish	A	B	C	D (Thread)	E	F	G	Weight
13088	15 30 40	Steel	1045	Bright Zinc	16.00mm	8.00mm	11.60mm	M4 x 0.7	4.60mm	1.00mm	7.90mm	.0045 kg
13090	15 30 40				16.00mm	8.00mm	11.60mm	M5 x 0.8	4.60mm	1.00mm	7.90mm	.0045 kg
13092	15 30 40				16.00mm	8.00mm	11.60mm	M6 x 1.0	4.60mm	1.00mm	7.90mm	.0041 kg
13094	15 30 40				16.00mm	8.00mm	11.60mm	M8 x 1.25	4.60mm	1.00mm	7.90mm	.0036 kg
13096	15 30 40				16.00mm	8.00mm	11.60mm	1/4-20	4.60mm	1.00mm	7.90mm	.0041 kg
13098	15 30 40				16.00mm	8.00mm	11.60mm	5/16-18	4.60mm	1.00mm	7.90mm	.0041kg
13058	45				20.00mm	10.00mm	15.00mm	M5 x 0.8	6.00mm	2.00mm	9.80mm	.0100 kg
13060	45				20.00mm	10.00mm	15.00mm	M6 x 1.0	6.00mm	2.00mm	9.80mm	.0095 kg
13062	45				20.00mm	10.00mm	15.00mm	M8 x 1.25	6.00mm	2.00mm	9.80mm	.0082 kg

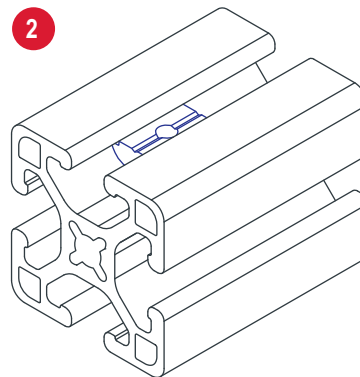
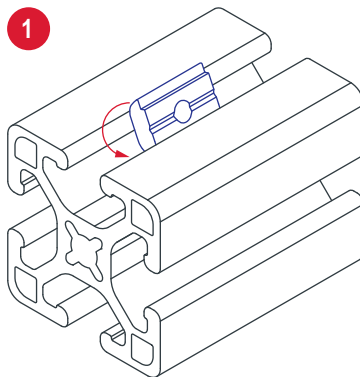

Part Description:

The tall self-aligning roll-in T-nut with spring leaf is a fastening option that loads either from the profile ends or side, which is helpful for applications where the ends are inaccessible. The projection on the T-nut aligns it in the T-slot while the spring leaf holds the fastener in place, even when the profile is in a vertical position. It is a strong and durable connection method that is available with different thread options. For information on 80/20 screw and bolt offerings for the tall self-aligning roll-in T-nut with spring leaf refer to pages beginning on 385.

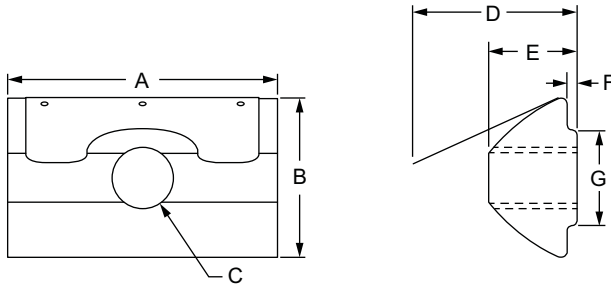

Part No.	Series	Material	Grade	Finish	A	B	C (Thread)	D	E	F	G	Weight
13030	15 40	Steel	1045	Bright Zinc	22.00mm	13.00mm	M5 x 0.8	13.40mm	7.19mm	0.79mm	7.80mm	.0113 kg
13033	15 40				22.00mm	13.00mm	M6 x 1.0	13.40mm	7.19mm	0.79mm	7.80mm	.0109 kg
13036	15 40				22.00mm	13.00mm	M8 x 1.25	13.40mm	7.19mm	0.79mm	7.80mm	.0095 kg
13038	15 40				22.00mm	13.00mm	1/4-20	13.40mm	7.19mm	0.79mm	7.80mm	.0109 kg
13041	15 40				22.00mm	13.00mm	5/16-18	13.40mm	7.19mm	0.79mm	7.80mm	.0100 kg

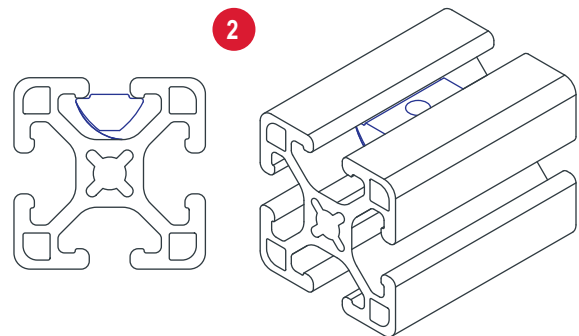
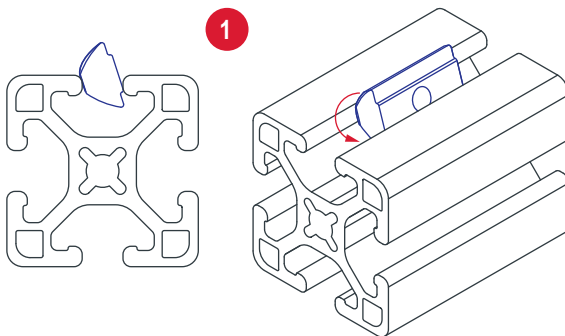

Short Self-Aligning Roll-In T-Nut with Spring Leaf

Part Description:

The short self-aligning roll-in T-nut with spring leaf is a fastening option that loads either from the profile ends or side, which is helpful in applications where the ends are inaccessible. The projection on the T-nut aligns it in the T-slot while the spring leaf holds the fastener in place, even when the profile is in a vertical position. It is available with options in size and thread. For information on 80/20 screw and bolt offerings for the short self-aligning roll-in T-nut with spring leaf refer to pages beginning on 385.

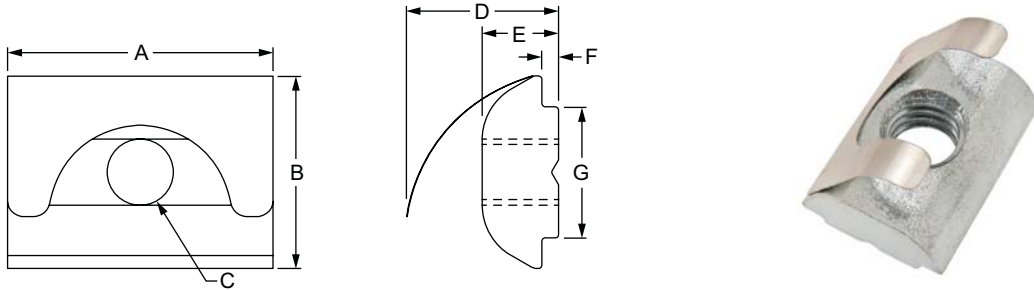

Part No.	Series	Material	Grade	Finish	A	B	C (Thread)	D	E	F	G	Weight
13089	15 30 40	Steel	1045	Bright Zinc	16.00mm	11.80mm	M4 x 0.7	9.30mm	4.30mm	1.00mm	8.00mm	.0045 kg
13091	15 30 40				16.00mm	11.80mm	M5 x 0.8	9.30mm	4.30mm	1.00mm	8.00mm	.0045 kg
13093	15 30 40				16.00mm	11.80mm	M6 x 1.0	9.30mm	4.30mm	1.00mm	8.00mm	.0045 kg
13095	15 30 40				16.00mm	11.80mm	M8 x 1.25	9.30mm	4.30mm	1.00mm	8.00mm	.0036 kg
13059	45				20.00mm	15.00mm	M5 x 0.8	13.65mm	6.00mm	1.50mm	10.00mm	.0100 kg
13061	45				20.00mm	15.00mm	M6 x 1.0	13.65mm	6.00mm	1.50mm	10.00mm	.0095 kg
13063	45				20.00mm	15.00mm	M8 x 1.25	13.65mm	6.00mm	1.50mm	10.00mm	.0086 kg

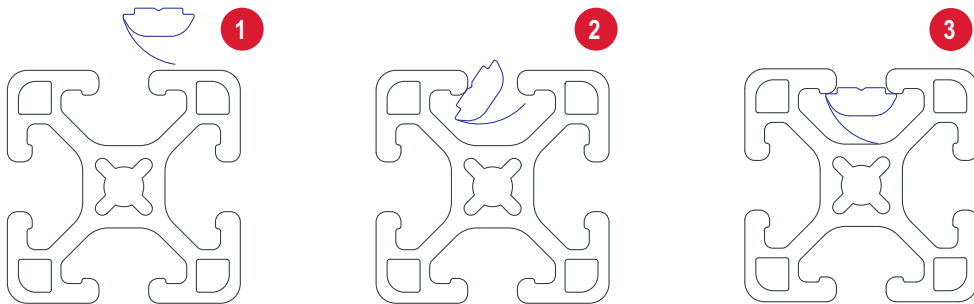

Part Description:

The economy drop-in T-nut is a fastening option that loads either from the profile ends or side, which is helpful for applications where the ends are inaccessible. It is a cost-effective fastener that provides infinite positioning along the profile T-slot and is available in an option of threads. For information on 80/20 screw and bolt offerings for the economy drop-in T-nut refer to pages beginning on 385.

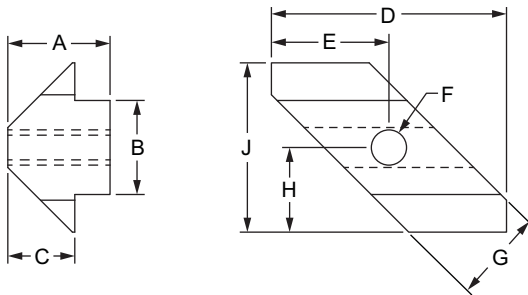

Part No.	Series	Material	Grade	Finish	A	B	C	D	E	F (Thread)	G	H	J	Weight
13179	15 40	Zinc	Die-Cast	Bright Zinc	8.70mm	8.00mm	5.70mm	20.00mm	10.00mm	M3 x 0.5	7.80mm	10.00mm	20.00mm	.0050 kg
13180	15 40				8.70mm	8.00mm	5.70mm	20.00mm	10.00mm	M4 x 0.6	7.80mm	10.00mm	20.00mm	.0050 kg
13181	15 40				8.70mm	8.00mm	5.70mm	20.00mm	10.00mm	M5 x 0.8	7.80mm	10.00mm	20.00mm	.0045 kg
13182	15 40				8.70mm	8.00mm	5.70mm	20.00mm	10.00mm	M6 x 1.0	7.80mm	10.00mm	20.00mm	.0041 kg
14161	15 40				8.70mm	8.00mm	5.70mm	20.00mm	10.00mm	1/4-20	7.80mm	10.00mm	20.00mm	.0041 kg

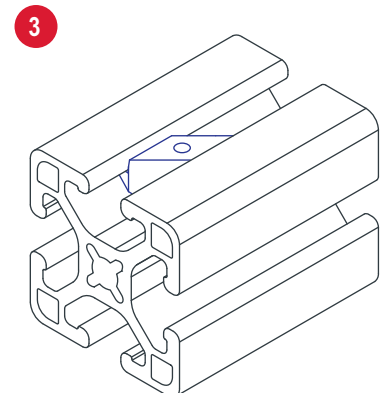
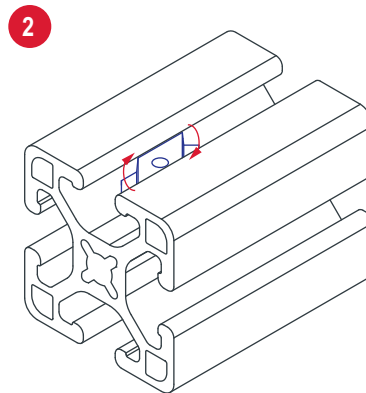
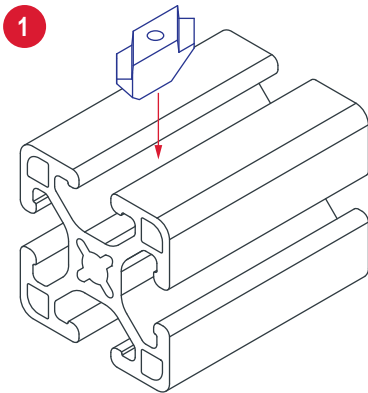

Standard Drop-In T-Nut

Part Description:

The standard drop-in T-nut is a fastening option that loads either from the profile ends or side, which is helpful for applications where the ends are inaccessible. It has ridges that bite into the profile surface, creating a strong connection. The standard drop-in T-nut is available with options in size, material, thread, and finish. For information on 80/20 screw and bolt offerings refer to pages beginning on 385.

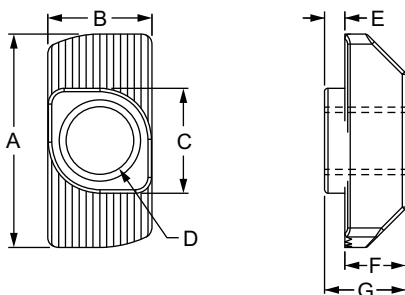

10 & 25 Series Standard Drop-In T-Nut

Part No.	Series	Material	Grade	Finish	A	B	C	D (Thread)	E	F	G	Weight
14162	10 25	Steel	1020	Bright Zinc	11.50mm	5.70mm	5.70mm	10-32	1.00mm	3.20mm	4.20mm	.0014 kg
14164	10 25				11.50mm	5.80mm	5.70mm	M4 x 0.7	1.00mm	3.20mm	4.20mm	.0014 kg
14166	10 25	Stainless-Steel	304 Stainless	Stainless	11.50mm	5.70mm	5.70mm	M4 x 0.7	1.00mm	3.20mm	4.20mm	.0014 kg

15 & 40 Series Standard Drop-In T-Nut

Part No.	Series	Material	Grade	Finish	A	B	C	D (Thread)	E	F	G	Weight
3930	15 40	Steel	1215	Bright Zinc	.620"	.305"	.308"	M5 x 0.8	.059"	.180"	.239"	.007 lb
3931	15 40		1215	Bright Zinc	.620"	.305"	.308"	M6 x 1.0	.059"	.180"	.239"	.006 lb
3932	15 40		1215	Bright Zinc	.620"	.305"	.308"	10-32	.059"	.180"	.239"	.007 lb
3933	15 40		1215	Bright Zinc	.620"	.305"	.308"	1/4-20	.059"	.180"	.239"	.007 lb
13116	15 40		1020	Bright Zinc	16.00mm	7.90mm	7.90mm	M5 x 0.8	3.00mm	4.70mm	7.70mm	.0041 kg
13119	15 40		1020	Bright Zinc	16.00mm	7.90mm	7.90mm	M6 x 1.0	3.00mm	4.70mm	7.70mm	.0037 kg
14165	15 40		1038	Bright Zinc	16.00mm	7.90mm	7.90mm	1/4-20	3.00mm	4.70mm	7.70mm	.0036 kg

30 Series Standard Drop-In T-Nut

Part No.	Series	Material	Grade	Finish	A	B	C	D (Thread)	E	F	G	Weight
13118	30	Stainless-Steel	304 Stainless	Stainless	16.00mm	8.00mm	8.00mm	M6 x 1.0	1.50mm	4.50mm	6.00mm	.0036 kg
13111	30	Stainless-Steel	304 Stainless	Stainless	15.80mm	7.90mm	7.70mm	1/4-20	1.50mm	4.50mm	6.00mm	.0027 kg
13113	30	Steel	1020	Bright Zinc	16.00mm	8.00mm	8.00mm	M4 x 0.7	1.50mm	4.50mm	6.00mm	.0041 kg
13115	30	Stainless-Steel	304 Stainless	Stainless	16.00mm	8.00mm	8.00mm	M5 x 0.8	1.50mm	4.50mm	6.00mm	.0034 kg
13117	30	Steel	1038	Bright Zinc	16.00mm	8.00mm	8.00mm	M6 x 1.0	1.50mm	4.50mm	6.00mm	.0032 kg
13112	30	Steel	1038	Bright Zinc	16.00mm	8.00mm	7.80mm	10-32	1.70mm	4.70mm	6.40mm	.0036 kg
13110	30	Steel	1038	Bright Zinc	16.00mm	8.00mm	8.00mm	1/4-20	1.50mm	4.50mm	6.00mm	.0032 kg

CONTINUE

45 Series Standard Drop-In T-Nut

Part No.	Series	Material	Grade	Finish	A	B	C	D (Thread)	E	F	G	Weight
13123	45	Steel	1020	Bright Zinc	19.60mm	9.80mm	9.90mm	M4 x 0.7	3.00mm	5.50mm	8.50mm	.0077 kg
13127	45				19.60mm	9.80mm	9.90mm	M5 x 0.8	3.00mm	5.50mm	8.50mm	.0073 kg
13129	45				19.60mm	9.80mm	9.90mm	M6 x 1.0	3.00mm	5.50mm	8.50mm	.0068 kg
13132	45				19.60mm	9.80mm	9.90mm	M8 x 1.25	3.00mm	5.50mm	8.50mm	.0059 kg
13122	45				19.60mm	9.80mm	9.90mm	10-32	3.00mm	5.50mm	8.50mm	.0077 kg
13120	45				19.60mm	9.80mm	9.80mm	1/4-20	3.00mm	5.50mm	8.50mm	.0068 kg
13124	45				19.60mm	9.80mm	9.90mm	5/16-18	3.00mm	5.50mm	8.50mm	.0054 kg
13130	45				Stainless-Steel	304 Stainless	Stainless	19.60mm	9.90mm	9.90mm	M6 x 1.0	3.00mm
13133	45	19.60mm	9.90mm	9.90mm				M8 x 1.25	3.00mm	5.70mm	8.70mm	.0059 kg
13121	45	19.20mm	9.80mm	9.80mm				1/4-20	3.00mm	5.70mm	8.70mm	.0068 kg
13125	45	19.20mm	9.90mm	9.90mm				5/16-18	3.00mm	5.50mm	8.50mm	.0064 kg

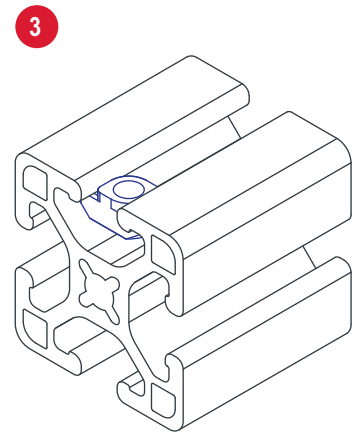
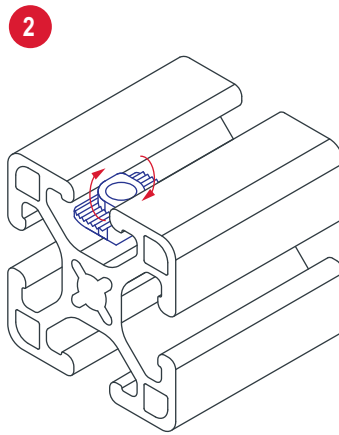
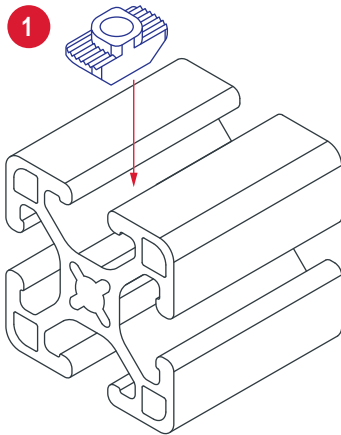

Slide-In T-Nut with Holding Spring

Part Description:

The slide-in T-nut with holding spring is a fastening option that is compatible with the 80/20 metric 45 series and loads from the profile ends. The projection on the T-nut aligns it in the T-slot while the spring holds the fastener in place, even when the profile is in a vertical position. The spring is removable and snaps onto the threaded projection. For information on 80/20 screw and bolt offerings for the slide-in T-nut with holding spring refer to pages beginning on 385.

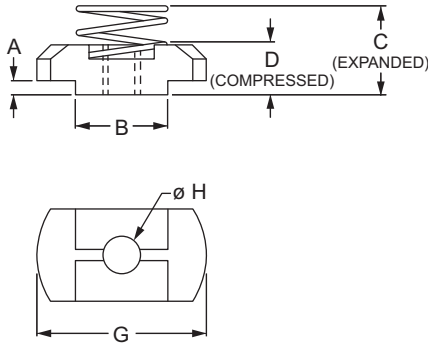

Part No.	Series	Material	Grade	Finish	A	B	C	D	E	F	G	H	Weight
13106	45	Steel	Property Class 8	Bright Zinc	1.50mm	9.80mm	12.00mm	6.00mm	5.30mm	9.80mm	18.00mm	M4 x 0.7	.0050 kg
13107	45				1.50mm	9.80mm	12.00mm	6.00mm	5.30mm	9.80mm	18.00mm	M5 x 0.8	.0045 kg
13108	45				1.50mm	9.80mm	12.00mm	6.00mm	5.30mm	9.80mm	18.00mm	M6 x 1.0	.0045 kg
13109	45				1.50mm	9.80mm	12.00mm	6.00mm	5.30mm	9.80mm	18.00mm	M8 x 1.25	.0036 kg

Part Description:

The double anchor slide-in T-nut is used with a double anchor fastener. It loads from the profile end and is a strong, durable connection. There are options available in size, thread, and finish. **Important:** The double anchor slide-in T-nut can only be used with a double anchor fastener. See page 214 for information on the double anchor fastener.

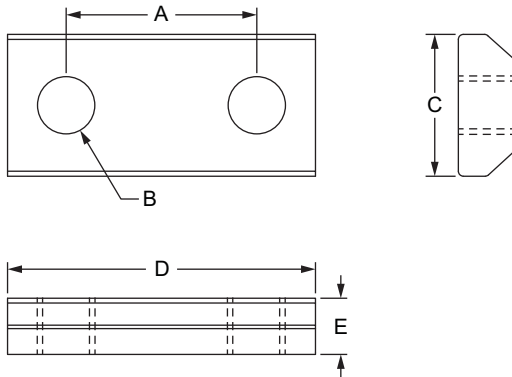

Part No.	Series	Material	Grade	Finish	A	B (Thread)	C	D	E	Weight
3085	10	Steel	1215	Black Zinc	.580"	10-32	.431"	.936"	.171"	.015 lb
3086	10			Black Zinc	1.580"	10-32	.431"	1.936"	.171"	.038 lb
3903	10			Bright Zinc	.565"	M5 x 0.8	.431"	.937"	.171"	.016 lb
3906	10			Bright Zinc	1.566"	M5 x 0.8	.431"	1.937"	.171"	.034 lb
3087	15			Black Zinc	.875"	5/16-18	.625"	1.437"	.250"	.046 lb
3088	15			Black Zinc	2.362"	5/16-18	.625"	2.937"	.250"	.105 lb
3908	15			Bright Zinc	.875"	M8 x 1.25	.625"	1.437"	.250"	.044 lb
3910	15			Bright Zinc	2.362"	M8 x 1.25	.625"	2.937"	.250"	.107 lb
25-3085	25			Bright Zinc	14.30mm	M5 x 0.8	10.95mm	24.46mm	4.34mm	.0068 kg
25-3086	25			Bright Zinc	39.57mm	M5 x 0.8	10.95mm	49.17mm	4.34mm	.0154 kg
40-3087	40			Bright Zinc	24.00mm	M8 x 1.25	15.88mm	38.25mm	6.16mm	.0228 kg
40-3088	40			Bright Zinc	64.01mm	M8 x 1.25	15.88mm	78.16mm	6.16mm	.0516 kg

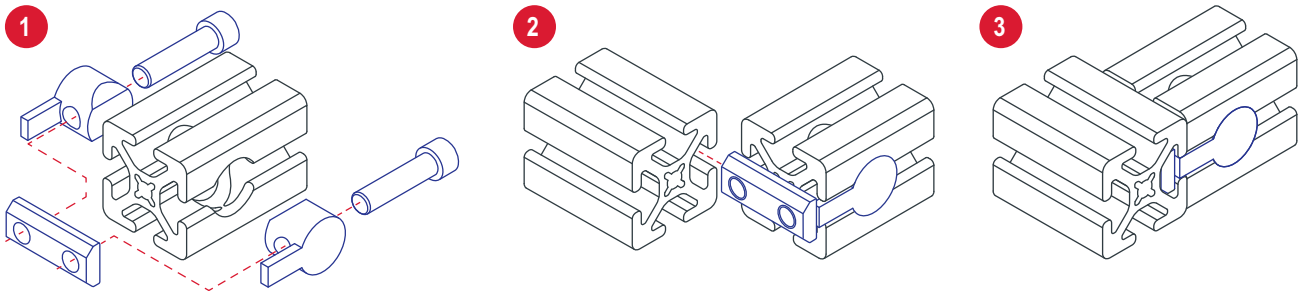

Nylon T-Slot Nut

Part Description:

The nylon T-slot nut is a light-duty fastening method typically used for accessories. The T-slot nut remains in place even when used in a vertical position. When used with a sheet metal screw, the nut expands into the T-slot. There are options available with or without the screws. **Additional Information:** Please note that nylon T-slot nuts 3346 and 40-3346 are sold in packs of 50 and 3348 and 40-3348 are sold in packs of 12.

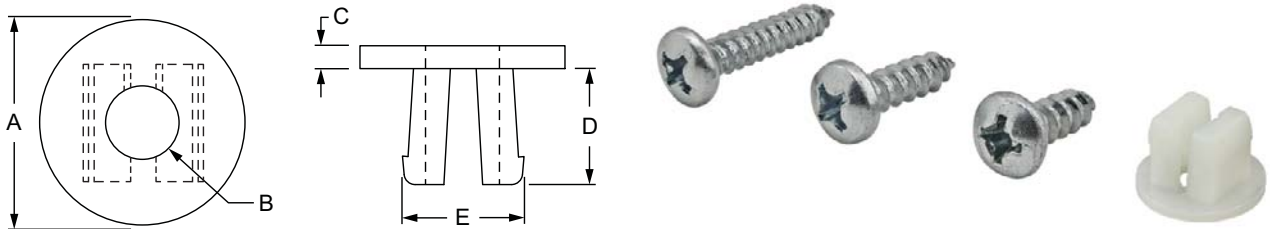

Part No.	Series	Screw	Qty.	Material	Grade	Color	A	B	C	D	E	Weight
3346	15	No	50	Plastic	Nylon	White	.557"	.200"	.062"	.330"	.315"	.001 lb
3348	15	Yes	12				.557"	.200"	.062"	.330"	.315"	.305 lb
40-3346	40	No	50				14.15mm	5.08mm	1.57mm	8.40mm	8.00mm	.0008 kg
40-3348	40	Yes	12				14.15mm	5.08mm	1.57mm	8.40mm	8.00mm	.1380 kg

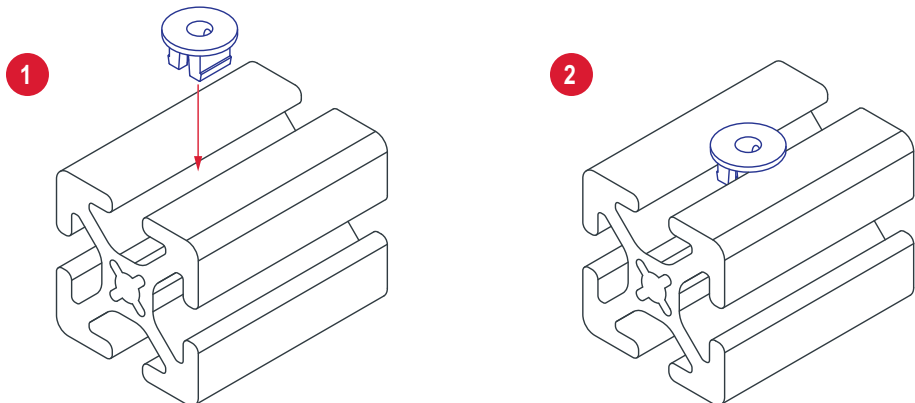

FASTENERS

Button Head Socket Cap Screw (BHSCS)

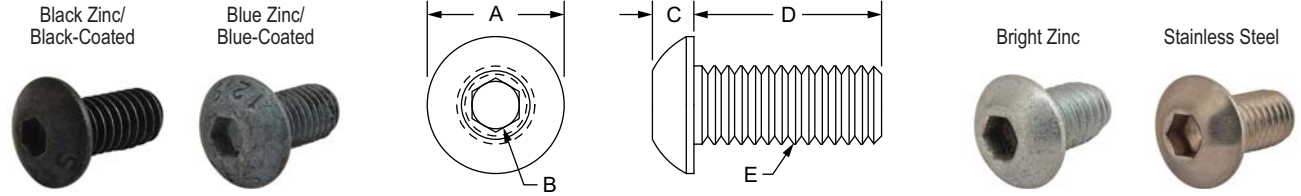

Part No.	Series	Material	Finish	A	B	C	D (Length)	E (Thread)	Thread Length	Weight
3005	F	Steel	Black Zinc	.305"	3/32	.082"	.375"	8-32	Full Thread	.002 lb
3024	F	Steel	Black Zinc	.305"	3/32	.082"	.500"	8-32	Full Thread	.003 lb
3032	F	Steel	Black Zinc	.305"	3/32	.082"	.875"	8-32	Full Thread	.005 lb
3042	F	Steel	Black Zinc	.354	1/8	.096"	.375"	10-32	Full Thread	.040 lb
3694	F	Stainless-Steel	Stainless	.354"	1/8	.096"	.375"	10-32	Full Thread	.004 lb
3050	F	Steel	Black Zinc	.354"	1/8	.096"	.500"	10-32	Full Thread	.005 lb
3696	F	Stainless-Steel	Stainless	.354"	1/8	.096"	.500"	10-32	Full Thread	.005 lb
3051	F	Steel	Black Zinc	.354"	1/8	.096"	.625"	10-32	Full Thread	.005 lb
3698	F	Stainless-Steel	Stainless	.354"	1/8	.096"	.625"	10-32	Full Thread	.006 lb
3054	F	Steel	Black Zinc	.354"	1/8	.096"	.750"	10-32	Full Thread	.006 lb
3059	F	Steel	Black Zinc	.428"	5/32	.127"	.375"	1/4-20	Full Thread	.007 lb
3688	F	Stainless-Steel	Stainless	.428"	5/32	.127"	.375"	1/4-20	Full Thread	.007 lb
65-3059	F	Steel	Black Zinc	.428"	5/32	.127"	.375"	1/4-20	Full Thread	.007 lb
3061	F	Steel	Black Zinc	.428"	5/32	.127"	.500"	1/4-20	Full Thread	.008 lb
3690	F	Stainless-Steel	Stainless	.428"	5/32	.127"	.500"	1/4-20	Full Thread	.008 lb
65-3061	F	Steel	Black Zinc	.428"	5/32	.127"	.500"	1/4-20	Full Thread	.008 lb
3063	F	Steel	Black Zinc	.428"	5/32	.127"	.625"	1/4-20	Full Thread	.009 lb
3663	F	Stainless-Steel	Stainless	.428"	5/32	.127"	.625"	1/4-20	Full Thread	.009 lb
65-3063	F	Steel	Black Zinc	.428"	5/32	.127"	.625"	1/4-20	Full Thread	.010 lb
3065	F	Steel	Black Zinc	.428"	5/32	.127"	.750"	1/4-20	Full Thread	.011 lb
3692	F	Stainless-Steel	Stainless	.428"	5/32	.127"	.750"	1/4-20	Full Thread	.010 lb
65-3065	F	Steel	Black Zinc	.428"	5/32	.127"	.750"	1/4-20	Full Thread	.011 lb
3104	F	Steel	Black Zinc	.537"	3/16	.159"	.500"	5/16-18	Full Thread	.014 lb
3609	F	Stainless-Steel	Stainless	.537"	3/16	.159"	.500"	5/16-18	Full Thread	.014 lb
3940	F	Steel	Bright Zinc	.537"	3/16	.159"	.500"	5/16-18	Full Thread	.018 lb
65-3104	F	Steel	Black Zinc	.537"	3/16	.159"	.500"	5/16-18	Full Thread	.014 lb
3111	F	Steel	Black Zinc	.537"	3/16	.159"	.625"	5/16-18	Full Thread	.020 lb
3611	F	Stainless-Steel	Stainless	.537"	3/16	.159"	.625"	5/16-18	Full Thread	.017 lb
65-3111	F	Steel	Black Zinc	.537"	3/16	.159"	.625"	5/16-18	Full Thread	.016 lb
3114	F	Steel	Black Zinc	.537"	3/16	.159"	.750"	5/16-18	Full Thread	.019 lb
3614	F	Stainless-Steel	Stainless	.537"	3/16	.159"	.750"	5/16-18	Full Thread	.019 lb
3941	F	Steel	Bright Zinc	.537"	3/16	.159"	.750"	5/16-18	Full Thread	.028 lb
65-3114	F	Steel	Black Zinc	.537"	3/16	.159"	.750"	5/16-18	Full Thread	.018 lb
3117	F	Steel	Black Zinc	.537"	3/16	.159"	.875"	5/16-18	Full Thread	.020 lb
3617	F	Stainless-Steel	Stainless	.537"	3/16	.159"	.875"	5/16-18	Full Thread	.021 lb
3118	F	Steel	Black Zinc	.537"	3/16	.159"	1.000"	5/16-18	Full Thread	.022 lb
3621	F	Stainless-Steel	Stainless	.537"	3/16	.159"	1.000"	5/16-18	Full Thread	.023 lb
3942	F	Steel	Bright Zinc	.537"	3/16	.159"	1.000"	5/16-18	Full Thread	.023 lb
65-3118	F	Steel	Black Zinc	.537"	3/16	.159"	1.000"	5/16-18	Full Thread	.022 lb

CONTINUE

Button Head Socket Cap Screw (Continued)

FASTENERS

Part No.	Series	Material	Finish	A	B	C	D (Length)	E (Thread)	Thread Length	Weight
3943	F	Steel	Bright Zinc	.537"	3/16	.159"	1.250"	5/16-18	Full Thread	.027 lb
3944	F	Steel	Bright Zinc	.537"	3/16	.159"	1.500"	5/16-18	Full Thread	.031 lb
3945	F	Steel	Bright Zinc	.537"	3/16	.159"	1.750"	5/16-18	Full Thread	.035 lb
3946	F	Steel	Bright Zinc	.537"	3/16	.159"	2.000"	5/16-18	Full Thread	.034 lb
3947	F	Steel	Bright Zinc	.537"	3/16	.159"	2.250"	5/16-18	Full Thread	.044 lb
3948	F	Steel	Bright Zinc	.537"	3/16	.159"	3.500"	5/16-18	Full Thread	.065 lb
11-4310	M	Steel	Black Zinc	7.60mm	2.50mm	2.20mm	10.00mm	M4 x 0.7	Full Thread	.0012 kg
11-4312	M	Steel	Black Zinc	7.60mm	2.50mm	2.20mm	12.00mm	M4 x 0.7	Full Thread	.0014 kg
11-5308	M	Steel	Black Zinc	9.32mm	3.00mm	2.63mm	8.00mm	M5 x 0.8	Full Thread	.0018 kg
11-5310	M	Steel	Black Zinc	9.32mm	3.00mm	2.63mm	10.00mm	M5 x 0.8	Full Thread	.0023 kg
13-5310	M	Steel	Blue Zinc	9.32mm	3.00mm	2.63mm	10.00mm	M5 x 0.8	Full Thread	.0023 kg
17-5310	M	Stainless-Steel	Stainless	9.32mm	3.00mm	2.63mm	10.00mm	M5 x 0.8	Full Thread	.0023 kg
11-5312	M	Steel	Black Zinc	9.32mm	3.00mm	2.63mm	12.00mm	M5 x 0.8	Full Thread	.0023 kg
13-5312	M	Steel	Blue Zinc	9.32mm	3.00mm	2.63mm	12.00mm	M5 x 0.8	Full Thread	.0023 kg
17-5312	M	Stainless-Steel	Stainless	9.32mm	3.00mm	2.63mm	12.00mm	M5 x 0.8	Full Thread	.0023 kg
11-5314	M	Steel	Black Zinc	9.32mm	3.00mm	2.63mm	14.00mm	M5 x 0.8	Full Thread	.0027 kg
11-5316	M	Steel	Black Zinc	9.32mm	3.00mm	2.63mm	16.00mm	M5 x 0.8	Full Thread	.0027 kg
13-5316	M	Steel	Blue Zinc	9.32mm	3.00mm	2.63mm	16.00mm	M5 x 0.8	Full Thread	.0027 kg
17-5316	M	Stainless-Steel	Stainless	9.32mm	3.00mm	2.63mm	16.00mm	M5 x 0.8	Full Thread	.0027 kg
13-5320	M	Steel	Blue Zinc	9.32mm	3.00mm	2.63mm	20.00mm	M5 x 0.8	Full Thread	.0032 kg
11-6310	M	Steel	Black Zinc	10.29mm	4.00mm	3.15mm	10.00mm	M6 x 1.0	Full Thread	.0032 kg
13-6310	M	Steel	Blue Zinc	10.29mm	4.00mm	3.15mm	10.00mm	M6 x 1.0	Full Thread	.0032 kg
17-6310	M	Stainless-Steel	Stainless	10.29mm	4.00mm	3.15mm	10.00mm	M6 x 1.0	Full Thread	.0032 kg
3802	M	Steel	Bright Zinc	10.29mm	4.00mm	3.15mm	12.00mm	M6 x 1.0	Full Thread	.0059 kg
11-6312	M	Steel	Black Zinc	10.29mm	4.00mm	3.15mm	12.00mm	M6 x 1.0	Full Thread	.0032 kg
13-6312	M	Steel	Blue Zinc	10.29mm	4.00mm	3.15mm	12.00mm	M6 x 1.0	Full Thread	.0032 kg
17-6312	M	Stainless-Steel	Stainless	10.29mm	4.00mm	3.15mm	12.00mm	M6 x 1.0	Full Thread	.0032 kg
19-6312	M	Steel	Bright Zinc	10.29mm	4.00mm	3.15mm	12.00mm	M6 x 1.0	Full Thread	.0032 kg
11-6314	M	Steel	Black Zinc	10.29mm	4.00mm	3.15mm	14.00mm	M6 x 1.0	Full Thread	.0036 kg
3804	M	Steel	Bright Zinc	10.29mm	4.00mm	3.15mm	16.00mm	M6 x 1.0	Full Thread	.0036 kg
11-6316	M	Steel	Black Zinc	10.29mm	4.00mm	3.15mm	16.00mm	M6 x 1.0	Full Thread	.0041 kg
13-6316	M	Steel	Blue Zinc	10.29mm	4.00mm	3.15mm	16.00mm	M6 x 1.0	Full Thread	.0041 kg
17-6316	M	Stainless-Steel	Stainless	10.29mm	4.00mm	3.15mm	16.00mm	M6 x 1.0	Full Thread	.0041 kg
19-6316	M	Steel	Bright Zinc	10.29mm	4.00mm	3.15mm	16.00mm	M6 x 1.0	Full Thread	.0039 kg
11-6318	M	Steel	Black Zinc	10.29mm	4.00mm	3.15mm	18.00mm	M6 x 1.0	Full Thread	.0045 kg
3808	M	Steel	Bright Zinc	10.29mm	4.00mm	3.15mm	20.00mm	M6 x 1.0	Full Thread	.0045 kg
11-6320	M	Steel	Black Zinc	10.29mm	4.00mm	3.15mm	20.00mm	M6 x 1.0	Full Thread	.0045 kg
13-6320	M	Steel	Blue Zinc	10.29mm	4.00mm	3.15mm	20.00mm	M6 x 1.0	Full Thread	.0045 kg
17-6320	M	Stainless-Steel	Stainless	10.29mm	4.00mm	3.15mm	20.00mm	M6 x 1.0	Full Thread	.0045 kg
19-6320	M	Steel	Bright Zinc	10.29mm	4.00mm	3.15mm	20.00mm	M6 x 1.0	Full Thread	.0045 kg
3809	M	Steel	Bright Zinc	10.29mm	4.00mm	3.15mm	25.00mm	M6 x 1.0	Full Thread	.0054 kg
13-6325	M	Steel	Blue Zinc	10.29mm	4.00mm	3.15mm	25.00mm	M6 x 1.0	Full Thread	.0054 kg
19-6325	M	Steel	Bright Zinc	10.29mm	4.00mm	3.15mm	25.00mm	M6 x 1.0	Full Thread	.0054 kg
3811	M	Steel	Bright Zinc	13.79mm	5.00mm	4.23mm	12.00mm	M8 x 1.25	Full Thread	.0064 kg
11-8312	M	Steel	Black Zinc	13.79mm	5.00mm	4.23mm	12.00mm	M8 x 1.25	Full Thread	.0068 kg
13-8312	M	Steel	Blue Zinc	13.79mm	5.00mm	4.23mm	12.00mm	M8 x 1.25	Full Thread	.0068 kg
13-3940	M	Steel	Blue Zinc	14.00mm	8.00mm	6.60mm	12.00mm	M8 x 1.25	Full Thread	.0067 kg

View page 385 for dimensional drawing

CONTINUE



Button Head Socket Cap Screw (Continued) / Flanged Button Head Socket Cap Screw

Button Head Socket Cap Screw (BHSCS)

Part No.	Series	Material	Finish	A	B	C	D (Length)	E (Thread)	Thread Length	Weight
17-8312	M	Stainless-Steel	Stainless	13.79mm	5.00mm	4.23mm	12.00mm	M8 x 1.25	Full Thread	.0068 kg
19-8312	M	Steel	Bright Zinc	13.79mm	5.00mm	4.23mm	12.00mm	M8 x 1.25	Full Thread	.0068 kg
3813	M	Steel	Bright Zinc	13.79mm	5.00mm	4.23mm	16.00mm	M8 x 1.25	Full Thread	.0077 kg
11-8316	M	Steel	Black Zinc	13.79mm	5.00mm	4.23mm	16.00mm	M8 x 1.25	Full Thread	.0077 kg
13-8316	M	Steel	Blue Zinc	13.79mm	5.00mm	4.23mm	16.00mm	M8 x 1.25	Full Thread	.0077 kg
17-8316	M	Stainless-Steel	Stainless	13.79mm	5.00mm	4.23mm	16.00mm	M8 x 1.25	Full Thread	.0077 kg
19-8316	M	Steel	Bright Zinc	13.79mm	5.00mm	4.23mm	16.00mm	M8 x 1.25	Full Thread	.0077 kg
11-8318	M	Steel	Black Zinc	13.79mm	5.00mm	4.23mm	18.00mm	M8 x 1.25	Full Thread	.0082 kg
3815	M	Steel	Bright Zinc	13.79mm	5.00mm	4.23mm	20.00mm	M8 x 1.25	Full Thread	.0091 kg
11-8320	M	Steel	Black Zinc	13.79mm	5.00mm	4.23mm	20.00mm	M8 x 1.25	Full Thread	.0092 kg
13-8320	M	Steel	Blue Zinc	13.79mm	5.00mm	4.23mm	20.00mm	M8 x 1.25	Full Thread	.0092 kg
13-3941	M	Steel	Blue Zinc	13.79mm	5.00mm	4.23mm	20.00mm	M8 x 1.25	Full Thread	.0092 kg
17-8320	M	Stainless-Steel	Stainless	13.79mm	5.00mm	4.23mm	20.00mm	M8 x 1.25	Full Thread	.0092 kg
19-8320	M	Steel	Bright Zinc	13.79mm	5.00mm	4.23mm	20.00mm	M8 x 1.25	Full Thread	.0092 kg
3819	M	Steel	Bright Zinc	13.79mm	5.00mm	4.23mm	25.00mm	M8 x 1.25	Full Thread	.0104 kg
11-8325	M	Steel	Black Zinc	13.79mm	5.00mm	4.23mm	25.00mm	M8 x 1.25	Full Thread	.0104 kg
13-8325	M	Steel	Blue Zinc	13.79mm	5.00mm	4.23mm	25.00mm	M8 x 1.25	Full Thread	.0104 kg
13-3942	M	Steel	Blue Zinc	13.79mm	5.00mm	4.23mm	25.00mm	M8 x 1.25	Full Thread	.0107 kg
17-8325	M	Stainless-Steel	Stainless	13.79mm	5.00mm	4.23mm	25.00mm	M8 x 1.25	Full Thread	.0104 kg
19-8325	M	Steel	Bright Zinc	13.79mm	5.00mm	4.23mm	25.00mm	M8 x 1.25	Full Thread	.0104 kg
13-3943	M	Steel	Blue Zinc	14.00mm	8.00mm	6.60mm	30.00mm	M8 x 1.25	Full Thread	.0121 kg
13-3944	M	Steel	Blue Zinc	14.00mm	8.00mm	6.60mm	40.00mm	M8 x 1.25	Full Thread	.0154 kg
13-3945	M	Steel	Blue Zinc	14.00mm	8.00mm	6.60mm	45.00mm	M8 x 1.25	Full Thread	.0169 kg
13-3946	M	Steel	Blue Zinc	14.00mm	8.00mm	6.60mm	50.00mm	M8 x 1.25	Full Thread	.0187 kg
13-3947	M	Steel	Blue Zinc	14.00mm	8.00mm	6.60mm	60.00mm	M8 x 1.25	Full Thread	.0217 kg
13-3948	M	Steel	Blue Zinc	14.00mm	8.00mm	6.60mm	80.00mm	M8 x 1.25	Full Thread	.0263 kg

View page 385 for dimensional drawing

Flanged Button Head Socket Cap Screw (FBHSCS)

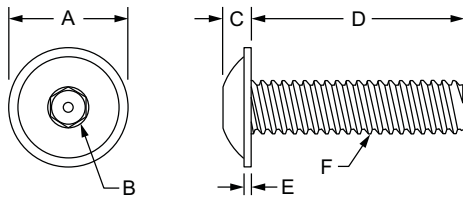

Part No.	Series	Material	Finish	A	B	C	D (Length)	E	F (Thread)	Thread Length	Weight
3390	F	Steel	Black Zinc	.560"	5/32	.132"	.375"	.046"	1/4-20	Full Thread	.007 lb
3601	F	Stainless-Steel	Stainless	.560"	5/32	.132"	.375"	.046"	1/4-20	Full Thread	.007 lb
3342	F	Steel	Black Zinc	.560"	5/32	.132"	.500"	.046"	1/4-20	Full Thread	.009 lb
3603	F	Stainless-Steel	Stainless	.560"	5/32	.132"	.500"	.046"	1/4-20	Full Thread	.008 lb
3066	F	Steel	Black Zinc	.560"	5/32	.132"	.750"	.046"	1/4-20	Full Thread	.011 lb
3604	F	Stainless-Steel	Stainless	.560"	5/32	.132"	.750"	.046"	1/4-20	Full Thread	.011 lb
3340	F	Steel	Black Zinc	.660"	3/16	.166"	.500"	.060"	5/16-18	Full Thread	.017 lb

CONTINUE

Flanged Button Head Socket Cap Screw (Continued) / Flat Head Socket Cap Screw

Flanged Button Head Socket Cap Screw (FBHSCS)

Part No.	Series	Material	Finish	A	B	C	D (Length)	E	F (Thread)	Thread Length	Weight
3606	F	Stainless-Steel	Stainless	.660"	3/16	.166"	.500"	.060"	5/16-18	Full Thread	.016 lb
3330	F	Steel	Black Zinc	.660"	3/16	.166"	.687"	.060"	5/16-18	Full Thread	.019 lb
3607	F	Stainless-Steel	Stainless	.660"	3/16	.166"	.687"	.060"	5/16-18	Full Thread	.019 lb
13-6410	M	Steel	Blue Zinc	13.25mm	4.00mm	3.15mm	10.00mm	1.10mm	M6 x 1.0	Full Thread	.0034 kg
17-6410	M	Stainless-Steel	Stainless	13.25mm	4.06mm	3.15mm	10.00mm	1.10mm	M6 x 1.0	Full Thread	.0034 kg
13-6412	M	Steel	Blue Zinc	13.25mm	4.00mm	3.15mm	12.00mm	1.10mm	M6 x 1.0	Full Thread	.0038 kg
17-6412	M	Stainless-Steel	Stainless	13.25mm	4.06mm	3.15mm	12.00mm	1.10mm	M6 x 1.0	Full Thread	.0038 kg
13-6416	M	Steel	Blue Zinc	13.25mm	4.00mm	3.15mm	16.00mm	1.10mm	M6 x 1.0	Full Thread	.0044 kg
17-6416	M	Stainless-Steel	Stainless	13.25mm	4.06mm	3.15mm	16.00mm	1.10mm	M6 x 1.0	Full Thread	.0044 kg
13-8416	M	Steel	Blue Zinc	17.45mm	5.00mm	4.25mm	16.00mm	1.38mm	M8 x 1.25	Full Thread	.0090 kg
17-8416	M	Stainless-Steel	Stainless	17.45mm	5.00mm	4.25mm	16.00mm	1.38mm	M8 x 1.25	Full Thread	.0118 kg
13-8425	M	Steel	Blue Zinc	17.45mm	5.00mm	4.25mm	25.00mm	1.38mm	M8 x 1.25	Full Thread	.0090 kg
17-8425	M	Stainless-Steel	Stainless	17.45mm	5.00mm	4.25mm	25.00mm	1.38mm	M8 x 1.25	Full Thread	.0118 kg

View page 387 for dimensional drawing

Flat Head Socket Cap Screw (FHSCS)

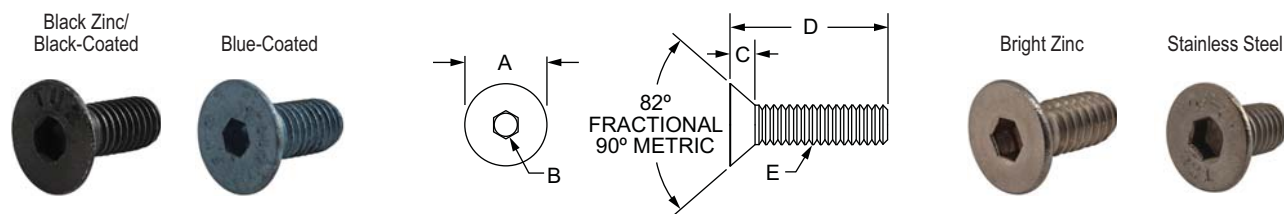

Part No.	Series	Material	Finish	A	B	C	D (Length)	E (Thread)	Thread Length	Weight
3649	F	Stainless-Steel	Stainless	.335"	3/32	.105"	.250"	8-32	Full Thread	.002 lb
3650	F	Stainless-Steel	Stainless	.385"	1/8	.127"	.375"	10-24	Full Thread	.003 lb
3022	F	Steel	Black Zinc	.385"	1/8	.127"	.500"	10-32	Full Thread	.004 lb
3012	F	Steel	Black Zinc	.506"	5/32	.161"	.375"	1/4-20	Full Thread	.006 lb
3400	F	Steel	Black Zinc	.506"	5/32	.161"	.500"	1/4-20	Full Thread	.009 lb
3645	F	Stainless-Steel	Stainless	.506"	5/32	.161"	.500"	1/4-20	Full Thread	.008 lb
3405	F	Steel	Black Zinc	.506"	5/32	.161"	.625"	1/4-20	Full Thread	.010 lb
3677	F	Stainless-Steel	Stainless	.506"	5/32	.161"	.625"	1/4-20	Full Thread	.009 lb
3406	F	Steel	Black Zinc	.506"	5/32	.161"	.750"	1/4-20	Full Thread	.011 lb
3011	F	Steel	Black Zinc	.628"	3/16	.198"	.500"	5/16-18	Full Thread	.014 lb
3410	F	Steel	Black Zinc	.628"	3/16	.198"	.625"	5/16-18	Full Thread	.017 lb
3411	F	Steel	Black Zinc	.628"	3/16	.198"	.750"	5/16-18	Full Thread	.018 lb
3420	F	Steel	Black Zinc	.751"	7/32	.234"	.750"	3/8-16	Full Thread	.028 lb
11-4710	M	Steel	Black Zinc	8.25mm	2.50mm	2.48mm	10.00mm	M4 x 0.7	Full Thread	.0009 kg
11-4712	M	Steel	Black Zinc	8.25mm	2.50mm	2.48mm	12.00mm	M4 x 0.7	Full Thread	.0014 kg
11-5708	M	Steel	Black Zinc	10.32mm	3.00mm	3.10mm	8.00mm	M5 x 0.8	Full Thread	.0014 kg
11-5710	M	Steel	Black Zinc	10.32mm	3.00mm	3.10mm	10.00mm	M5 x 0.8	Full Thread	.0018 kg
11-5712	M	Steel	Black Zinc	10.32mm	3.00mm	3.10mm	12.00mm	M5 x 0.8	Full Thread	.0018 kg
13-5712	M	Steel	Blue Zinc	10.32mm	3.00mm	3.10mm	12.00mm	M5 x 0.8	Full Thread	.0018 kg
11-5714	M	Steel	Black Zinc	10.32mm	3.00mm	3.10mm	14.00mm	M5 x 0.8	Full Thread	.0027 kg

CONTINUE

80/20® Flat Head Socket Cap Screw (Continued) / Socket Head Cap Screw

Flat Head Socket Cap Screw (FHSCS)

Part No.	Series	Material	Finish	A	B	C	D (Length)	E (Thread)	Thread Length	Weight
11-5716	M	Steel	Black Zinc	10.32mm	3.00mm	3.10mm	16.00mm	M5 x 0.8	Full Thread	.0027 kg
13-6710	M	Steel	Blue Zinc	12.39mm	4.00mm	3.72mm	10.00mm	M6 x 1.0	Full Thread	.0023 kg
13-6712	M	Steel	Blue Zinc	12.39mm	4.00mm	3.72mm	12.00mm	M6 x 1.0	Full Thread	.0027 kg
17-6712	M	Stainless-Steel	Stainless	12.39mm	4.00mm	3.72mm	12.00mm	M6 x 1.0	Full Thread	.0032 kg
11-6714	M	Steel	Black Zinc	12.39mm	4.00mm	3.72mm	14.00mm	M6 x 1.0	Full Thread	.0032 kg
11-6716	M	Steel	Black Zinc	12.39mm	4.00mm	3.72mm	16.00mm	M6 x 1.0	Full Thread	.0036 kg
13-6716	M	Steel	Blue Zinc	12.39mm	4.00mm	3.72mm	16.00mm	M6 x 1.0	Full Thread	.0036 kg
11-6718	M	Steel	Black Zinc	12.39mm	4.00mm	3.72mm	18.00mm	M6 x 1.0	Full Thread	.0041 kg
11-6720	M	Steel	Black Zinc	12.39mm	4.00mm	3.72mm	20.00mm	M6 x 1.0	Full Thread	.0041 kg
13-8712	M	Steel	Blue Zinc	16.58mm	5.00mm	4.96mm	12.00mm	M8 x 1.25	Full Thread	.0059 kg
11-8716	M	Steel	Black Zinc	16.58mm	5.00mm	4.96mm	16.00mm	M8 x 1.25	Full Thread	.0073 kg
13-8716	M	Steel	Blue Zinc	16.58mm	5.00mm	4.96mm	16.00mm	M8 x 1.25	Full Thread	.0073 kg
11-8720	M	Steel	Black Zinc	16.58mm	5.00mm	4.96mm	20.00mm	M8 x 1.25	Full Thread	.0082 kg
13-8720	M	Steel	Blue Zinc	16.58mm	5.00mm	4.96mm	20.00mm	M8 x 1.25	Full Thread	.0082 kg
13-1716	M	Steel	Blue Zinc	22.40mm	6.00mm	5.50mm	16.00mm	M10 x 1.50	Full Thread	.0150 kg
40-3650	40	Stainless-Steel	Stainless	9.78mm	3.18mm	3.23mm	9.53mm	10-24	Full Thread	.0015 kg

View page 388 for dimensional drawing

Socket Head Cap Screw (SHCS)

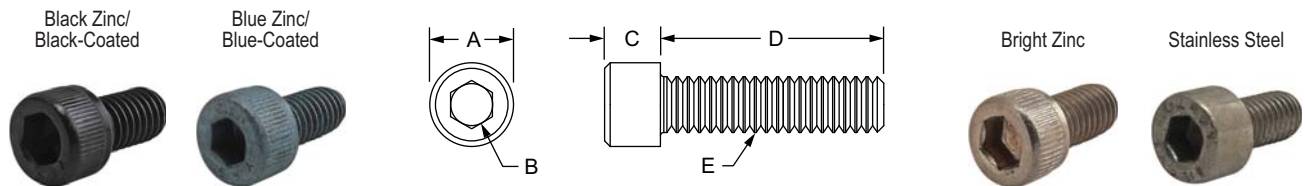

Part No.	Series	Material	Finish	A	B	C	D (Length)	E (Thread)	Thread Length	Weight
3044	F	Steel	Black Zinc	.308"	5/32	.188"	.375"	10-32	Full Thread	.005 lb
3693	F	Stainless-Steel	Stainless	.308"	5/32	.188"	.375"	10-32	Full Thread	.005 lb
3048	F	Steel	Black Zinc	.308"	5/32	.188"	.500"	10-32	Full Thread	.006 lb
3695	F	Stainless-Steel	Stainless	.308"	5/32	.188"	.500"	10-32	Full Thread	.006 lb
3052	F	Steel	Black Zinc	.308"	5/32	.188"	.625"	10-32	Full Thread	.006 lb
3697	F	Stainless-Steel	Stainless	.308"	5/32	.188"	.625"	10-32	Full Thread	.007 lb
3056	F	Steel	Black Zinc	.308"	5/32	.188"	.750"	10-32	Full Thread	.008 lb
3685	F	Stainless-Steel	Stainless	.308"	5/32	.188"	.750"	10-32	Full Thread	.007 lb
3057	F	Steel	Black Zinc	.308"	5/32	.188"	.875"	10-32	Full Thread	.008 lb
3058	F	Steel	Black Zinc	.370"	3/16	.247"	.375"	1/4-20	Full Thread	.006 lb
3687	F	Stainless-Steel	Stainless	.370"	3/16	.247"	.375"	1/4-20	Full Thread	.006 lb
65-3058	F	Steel	Black Zinc	.370"	3/16	.247"	.375"	1/4-20	Full Thread	.008 lb
3062	F	Steel	Black Zinc	.370"	3/16	.247"	.500"	1/4-20	Full Thread	.011 lb
3689	F	Stainless-Steel	Stainless	.370"	3/16	.247"	.500"	1/4-20	Full Thread	.010 lb
65-3062	F	Steel	Black Zinc	.370"	3/16	.247"	.500"	1/4-20	Full Thread	.011 lb
3067	F	Steel	Black Zinc	.370"	3/16	.247"	.625"	1/4-20	Full Thread	.012 lb
65-3067	F	Steel	Black Zinc	.370"	3/16	.247"	.625"	1/4-20	Full Thread	.009 lb

CONTINUE

Socket Head Cap Screw (Continued)

Part No.	Series	Material	Finish	A	B	C	D (Length)	E (Thread)	Thread Length	Weight
3064	F	Steel	Black Zinc	.370"	3/16	.247"	.750"	1/4-20	Full Thread	.013 lb
3691	F	Stainless-Steel	Stainless	.370"	3/16	.247"	.750"	1/4-20	Full Thread	.013 lb
65-3064	F	Steel	Black Zinc	.370"	3/16	.247"	.750"	1/4-20	Full Thread	.013 lb
3068	F	Steel	Black Zinc	.370"	3/16	.247"	.875"	1/4-20	Full Thread	.014 lb
3071	F	Steel	Black Zinc	.370"	3/16	.247"	1.000"	1/4-20	Full Thread	.015 lb
3671	F	Stainless-Steel	Stainless	.370"	3/16	.247"	1.000"	1/4-20	Full Thread	.016 lb
65-3071	F	Steel	Black Zinc	.370"	3/16	.247"	1.000"	1/4-20	Full Thread	.015 lb
3072	F	Steel	Black Zinc	.370"	3/16	.247"	1.250"	1/4-20	1.000"	.017 lb
3080	F	Steel	Black Zinc	.370"	3/16	.247"	1.500"	1/4-20	1.000"	.010 lb
3081	F	Steel	Black Zinc	.370"	3/16	.247"	2.125"	1/4-20	1.000"	.030 lb
3082	F	Steel	Black Zinc	.370"	3/16	.247"	2.500"	1/4-20	1.000"	.035 lb
3106	F	Steel	Black Zinc	.463"	1/4	.309"	.500"	5/16-18	Full Thread	.019 lb
3610	F	Stainless-Steel	Stainless	.463"	1/4	.309"	.500"	5/16-18	Full Thread	.019 lb
3950	F	Steel	Bright Zinc	.463"	1/4	.309"	.500"	5/16-18	Full Thread	.018 lb
65-3106	F	Steel	Black Zinc	.463"	1/4	.309"	.500"	5/16-18	Full Thread	.019 lb
3110	F	Steel	Black Zinc	.463"	1/4	.309"	.625"	5/16-18	Full Thread	.021 lb
3612	F	Stainless-Steel	Stainless	.463"	1/4	.309"	.625"	5/16-18	Full Thread	.021 lb
65-3110	F	Steel	Black Zinc	.463"	1/4	.309"	.625"	5/16-18	Full Thread	.021 lb
3112	F	Steel	Black Zinc	.463"	1/4	.309"	.750"	5/16-18	Full Thread	.023 lb
3615	F	Stainless-Steel	Stainless	.463"	1/4	.309"	.750"	5/16-18	Full Thread	.023 lb
3951	F	Steel	Bright Zinc	.463"	1/4	.309"	.750"	5/16-18	Full Thread	.023 lb
65-3112	F	Steel	Black Zinc	.463"	1/4	.309"	.750"	5/16-18	Full Thread	.023 lb
3119	F	Steel	Black Zinc	.463"	1/4	.309"	.875"	5/16-18	Full Thread	.025 lb
3619	F	Stainless-Steel	Stainless	.463"	1/4	.309"	.875"	5/16-18	Full Thread	.025 lb
3122	F	Steel	Black Zinc	.463"	1/4	.309"	1.000"	5/16-18	Full Thread	.027 lb
3622	F	Stainless-Steel	Stainless	.463"	1/4	.309"	1.000"	5/16-18	Full Thread	.027 lb
3952	F	Steel	Bright Zinc	.463"	1/4	.309"	1.000"	5/16-18	Full Thread	.027 lb
65-3122	F	Steel	Black Zinc	.463"	1/4	.309"	1.000"	5/16-18	Full Thread	.027 lb
3627	F	Stainless-Steel	Stainless	.463"	1/4	.309"	1.250"	5/16-18	Full Thread	.032 lb
3953	F	Steel	Bright Zinc	.463"	1/4	.309"	1.250"	5/16-18	Full Thread	.031 lb
65-3123	F	Steel	Black Zinc	.463"	1/4	.309"	1.250"	5/16-18	Full Thread	.032 lb
3123	F	Steel	Black Zinc	.463"	1/4	.309"	1.300"	5/16-18	Full Thread	.032 lb
3127	F	Steel	Black Zinc	.463"	1/4	.309"	1.500"	5/16-18	Full Thread	.035 lb
3954	F	Steel	Bright Zinc	.463"	1/4	.309"	1.500"	5/16-18	1.125"	.035 lb
3129	F	Steel	Black Zinc	.463"	1/4	.309"	1.750"	5/16-18	1.400"	.042 lb
3955	F	Steel	Bright Zinc	.463"	1/4	.309"	1.750"	5/16-18	1.125"	.043 lb
3130	F	Steel	Black Zinc	.463"	1/4	.309"	2.000"	5/16-18	1.650"	.046 lb
3956	F	Steel	Bright Zinc	.463"	1/4	.309"	2.000"	5/16-18	1.125"	.046 lb
3131	F	Steel	Black Zinc	.463"	1/4	.309"	2.250"	5/16-18	1.400"	.052 lb
3957	F	Steel	Bright Zinc	.463"	1/4	.309"	2.250"	5/16-18	1.125"	.052 lb
3132	F	Steel	Black Zinc	.463"	1/4	.309"	2.500"	5/16-18	1.125"	.056 lb
3133	F	Steel	Black Zinc	.463"	1/4	.309"	3.000"	5/16-18	1.650"	.067 lb
3140	F	Alloy Steel	Black Zinc	.463"	1/4	.309"	3.250"	5/16-18	1.400"	.073 lb
3958	F	Steel	Bright Zinc	.463"	1/4	.309"	3.500"	5/16-18	1.125"	.077 lb
3125	F	Steel	Black Zinc	.556"	5/16	.372"	.750"	3/8-16	Full Thread	.037 lb
3124	F	Steel	Black Zinc	.556"	5/16	.372"	1.000"	3/8-16	Full Thread	.049 lb
3128	F	Steel	Black Zinc	.743"	3/8	.496"	1.000"	1/2-13	Full Thread	.091 lb
11-4510	M	Steel	Black Zinc	7.00mm	3.00mm	3.91mm	10.00mm	M4 x 0.7	Full Thread	.0017 kg

View page 389 for dimensional drawing

CONTINUE



Socket Head Cap Screw (Continued)

Part No.	Series	Material	Finish	A	B	C	D (Length)	E (Thread)	Thread Length	Weight
11-4512	M	Steel	Black Zinc	7.00mm	3.00mm	3.91mm	12.00mm	M4 x 0.7	Full Thread	.0018 kg
11-4516	M	Steel	Black Zinc	7.00mm	3.00mm	3.91mm	16.00mm	M4 x 0.7	Full Thread	.0023 kg
11-5510	M	Steel	Black Zinc	8.39mm	4.00mm	4.91mm	10.00mm	M5 x 0.8	Full Thread	.0027 kg
13-5510	M	Steel	Blue Zinc	8.39mm	4.00mm	4.91mm	10.00mm	M5 x 0.8	Full Thread	.0027 kg
17-5510	M	Stainless-Steel	Stainless	8.39mm	4.00mm	4.91mm	10.00mm	M5 x 0.8	Full Thread	.0031 kg
11-5512	M	Steel	Black Zinc	8.39mm	4.00mm	4.91mm	12.00mm	M5 x 0.8	Full Thread	.0032 kg
13-5512	M	Steel	Blue Zinc	8.39mm	4.00mm	4.91mm	12.00mm	M5 x 0.8	Full Thread	.0032 kg
17-5512	M	Stainless-Steel	Stainless	8.39mm	4.00mm	4.91mm	12.00mm	M5 x 0.8	Full Thread	.0032 kg
11-5516	M	Steel	Black Zinc	8.39mm	4.00mm	4.91mm	16.00mm	M5 x 0.8	Full Thread	.0036 kg
13-5516	M	Steel	Blue Zinc	8.39mm	4.00mm	4.91mm	16.00mm	M5 x 0.8	Full Thread	.0036 kg
17-5516	M	Stainless-Steel	Stainless	8.39mm	4.00mm	4.91mm	16.00mm	M5 x 0.8	Full Thread	.0036 kg
11-5518	M	Steel	Black Zinc	8.50mm	4.00mm	4.00mm	18.00mm	M5 x 0.8	Full Thread	.0038 kg
13-5518	M	Steel	Blue Zinc	8.50mm	4.00mm	5.00mm	18.00mm	M5 x 0.8	Full Thread	.0038 kg
11-5520	M	Steel	Black Zinc	8.39mm	4.00mm	4.91mm	20.00mm	M5 x 0.8	Full Thread	.0039 kg
13-5520	M	Steel	Blue Zinc	8.39mm	4.00mm	4.91mm	20.00mm	M5 x 0.8	Full Thread	.0039 kg
17-5520	M	Stainless-Steel	Stainless	8.39mm	4.00mm	4.91mm	20.00mm	M5 x 0.8	Full Thread	.0039 kg
13-5525	M	Steel	Blue Zinc	8.50mm	4.00mm	5.00mm	25.00mm	M5 x 0.8	Full Thread	.0046 kg
13-5530	M	Steel	Blue Zinc	8.39mm	4.00mm	4.91mm	30.00mm	M5 x 0.8	22.00mm	.0054 kg
13-6508	M	Steel	Blue Zinc	10.00mm	5.00mm	6.00mm	8.00mm	M6 x 1.0	Full Thread	.0039 kg
11-6510	M	Steel	Black Zinc	9.89mm	5.00mm	5.85mm	10.00mm	M6 x 1.0	Full Thread	.0045 kg
13-6510	M	Steel	Blue Zinc	9.89mm	5.00mm	5.85mm	10.00mm	M6 x 1.0	Full Thread	.0045 kg
17-6510	M	Stainless-Steel	Stainless	9.89mm	5.00mm	5.85mm	10.00mm	M6 x 1.0	Full Thread	.0045 kg
3801	M	Steel	Bright Zinc	9.89mm	5.00mm	5.85mm	12.00mm	M6 x 1.0	Full Thread	.0045 kg
11-6512	M	Steel	Black Zinc	9.89mm	5.00mm	5.85mm	12.00mm	M6 x 1.0	Full Thread	.0045 kg
13-6512	M	Steel	Blue Zinc	9.89mm	5.00mm	5.85mm	12.00mm	M6 x 1.0	Full Thread	.0045 kg
17-6512	M	Stainless-Steel	Stainless	9.89mm	5.00mm	5.85mm	12.00mm	M6 x 1.0	Full Thread	.0045 kg
19-6512	M	Steel	Bright Zinc	9.89mm	5.00mm	5.85mm	12.00mm	M6 x 1.0	Full Thread	.0045 kg
11-6514	M	Steel	Black Zinc	9.89mm	5.00mm	5.85mm	14.00mm	M6 x 1.0	Full Thread	.0053 kg
3803	M	Steel	Bright Zinc	9.89mm	5.00mm	5.85mm	16.00mm	M6 x 1.0	Full Thread	.0054 kg
11-6516	M	Steel	Black Zinc	9.89mm	5.00mm	5.85mm	16.00mm	M6 x 1.0	Full Thread	.0054 kg
13-6516	M	Steel	Blue Zinc	9.89mm	5.00mm	5.85mm	16.00mm	M6 x 1.0	Full Thread	.0054 kg
17-6516	M	Stainless-Steel	Stainless	9.89mm	5.00mm	5.85mm	16.00mm	M6 x 1.0	Full Thread	.0054 kg
19-6516	M	Steel	Bright Zinc	9.89mm	5.00mm	5.85mm	16.00mm	M6 x 1.0	Full Thread	.0054 kg
11-6518	M	Steel	Black Zinc	9.89mm	5.00mm	5.85mm	18.00mm	M6 x 1.0	Full Thread	.0059 kg
3806	M	Steel	Bright Zinc	9.89mm	5.00mm	5.85mm	20.00mm	M6 x 1.0	Full Thread	.0059 kg
11-6520	M	Steel	Black Zinc	9.89mm	5.00mm	5.85mm	20.00mm	M6 x 1.0	Full Thread	.0058 kg
13-6520	M	Steel	Blue Zinc	9.89mm	5.00mm	5.85mm	20.00mm	M6 x 1.0	Full Thread	.0058 kg
17-6520	M	Stainless-Steel	Stainless	9.89mm	5.00mm	5.85mm	20.00mm	M6 x 1.0	Full Thread	.0058 kg
19-6520	M	Steel	Bright Zinc	9.89mm	5.00mm	5.85mm	20.00mm	M6 x 1.0	Full Thread	.0058 kg
3807	M	Steel	Bright Zinc	9.89mm	5.00mm	5.85mm	25.00mm	M6 x 1.0	Full Thread	.0064 kg
11-6525	M	Steel	Black Zinc	9.89mm	5.00mm	5.85mm	25.00mm	M6 x 1.0	Full Thread	.0068 kg
13-6525	M	Steel	Blue Zinc	9.89mm	5.00mm	5.85mm	25.00mm	M6 x 1.0	Full Thread	.0068 kg
19-6525	M	Steel	Bright Zinc	9.89mm	5.00mm	5.85mm	25.00mm	M6 x 1.0	Full Thread	.0068 kg
11-6530	M	Steel	Black Zinc	9.89mm	5.00mm	5.85mm	30.00mm	M6 x 1.0	Full Thread	.0077 kg
13-6530	M	Steel	Blue Zinc	9.89mm	5.00mm	5.85mm	30.00mm	M6 x 1.0	Full Thread	.0077 kg
11-6535	M	Steel	Black Zinc	9.89mm	5.00mm	5.85mm	35.00mm	M6 x 1.0	24.00mm	.0090 kg
13-6535	M	Steel	Blue Zinc	9.89mm	5.00mm	5.85mm	35.00mm	M6 x 1.0	24.00mm	.0091 kg
11-6540	M	Steel	Black Zinc	9.89mm	5.00mm	5.85mm	40.00mm	M6 x 1.0	24.00mm	.0104 kg

FASTENERS

View page 389 for dimensional drawing

CONTINUE

Socket Head Cap Screw (Continued)

Part No.	Series	Material	Finish	A	B	C	D (Length)	E (Thread)	Thread Length	Weight
13-6540	M	Steel	Blue Zinc	9.89mm	5.00mm	5.85mm	40.00mm	M6 x 1.0	24.00mm	.0104 kg
3810	M	Steel	Bright Zinc	12.87mm	6.00mm	7.82mm	12.00mm	M8 x 1.25	Full Thread	.0100 kg
11-8512	M	Steel	Black Zinc	12.87mm	6.00mm	7.82mm	12.00mm	M8 x 1.25	Full Thread	.0100 kg
13-3950	M	Steel	Blue Zinc	13.00mm	6.00mm	8.00mm	12.00mm	M8 x 1.25	Full Thread	.0102 kg
13-8512	M	Steel	Blue Zinc	12.87mm	6.00mm	7.82mm	12.00mm	M8 x 1.25	Full Thread	.0100 kg
17-8512	M	Stainless-Steel	Stainless	12.87mm	6.00mm	7.82mm	12.00mm	M8 x 1.25	Full Thread	.0100 kg
19-8512	M	Steel	Bright Zinc	12.87mm	6.00mm	7.82mm	12.00mm	M8 x 1.25	Full Thread	.0100 kg
3812	M	Steel	Bright Zinc	12.87mm	6.00mm	7.82mm	16.00mm	M8 x 1.25	Full Thread	.0113 kg
11-8516	M	Steel	Black Zinc	12.87mm	6.00mm	7.82mm	16.00mm	M8 x 1.25	Full Thread	.0113 kg
13-8516	M	Steel	Blue Zinc	12.87mm	6.00mm	7.82mm	16.00mm	M8 x 1.25	Full Thread	.0113 kg
17-8516	M	Stainless-Steel	Stainless	12.87mm	6.00mm	7.82mm	16.00mm	M8 x 1.25	Full Thread	.0113 kg
19-8516	M	Steel	Bright Zinc	12.87mm	6.00mm	7.82mm	16.00mm	M8 x 1.25	Full Thread	.0113 kg
11-8518	M	Steel	Black Zinc	12.87mm	6.00mm	7.82mm	18.00mm	M8 x 1.25	Full Thread	.0118 kg
13-8518	M	Steel	Blue Zinc	12.87mm	6.00mm	7.82mm	18.00mm	M8 x 1.25	Full Thread	.0118 kg
3814	M	Steel	Bright Zinc	12.87mm	6.00mm	7.82mm	20.00mm	M8 x 1.25	Full Thread	.0126 kg
11-8520	M	Steel	Black Zinc	12.87mm	6.00mm	7.82mm	20.00mm	M8 x 1.25	Full Thread	.0127 kg
13-3951	M	Steel	Blue Zinc	13.00mm	6.00mm	8.00mm	20.00mm	M8 x 1.25	Full Thread	.0128 kg
13-8520	M	Steel	Blue Zinc	12.87mm	6.00mm	7.82mm	20.00mm	M8 x 1.25	Full Thread	.0127 kg
17-8520	M	Stainless-Steel	Stainless	12.87mm	6.00mm	7.82mm	20.00mm	M8 x 1.25	Full Thread	.0127 kg
19-8520	M	Steel	Bright Zinc	12.87mm	6.00mm	7.82mm	20.00mm	M8 x 1.25	Full Thread	.0127 kg
13-8522	M	Steel	Blue Zinc	12.87mm	6.00mm	7.82mm	22.00mm	M8 x 1.25	Full Thread	.0132 kg
3818	M	Steel	Bright Zinc	12.87mm	6.00mm	7.82mm	25.00mm	M8 x 1.25	Full Thread	.0145 kg
11-8525	M	Steel	Black Zinc	12.87mm	6.00mm	7.82mm	25.00mm	M8 x 1.25	Full Thread	.0141 kg
13-8525	M	Steel	Blue Zinc	12.87mm	6.00mm	7.82mm	25.00mm	M8 x 1.25	Full Thread	.0141 kg
13-3952	M	Steel	Blue Zinc	13.00mm	6.00mm	8.00mm	25.00mm	M8 x 1.25	Full Thread	.0143 kg
17-8525	M	Stainless-Steel	Stainless	12.87mm	6.00mm	7.82mm	25.00mm	M8 x 1.25	Full Thread	.0141 kg
19-8525	M	Steel	Bright Zinc	12.87mm	6.00mm	7.82mm	25.00mm	M8 x 1.25	Full Thread	.0141 kg
3822	M	Steel	Bright Zinc	12.80 mm	6.00mm	7.82mm	30.00mm	M8 x 1.25	Full Thread	.0159 kg
11-8530	M	Steel	Black Zinc	12.87mm	6.00mm	7.82mm	30.00mm	M8 x 1.25	Full Thread	.0159 kg
13-8530	M	Steel	Blue Zinc	12.87mm	6.00mm	7.82mm	30.00mm	M8 x 1.25	Full Thread	.0159 kg
13-3953	M	Steel	Blue Zinc	13.00mm	6.00mm	8.00mm	30.00mm	M8 x 1.25	Full Thread	.0156 kg
17-8530	M	Stainless-Steel	Stainless	12.87mm	6.00mm	7.82mm	30.00mm	M8 x 1.25	Full Thread	.0159 kg
19-8530	M	Steel	Bright Zinc	12.87mm	6.00mm	7.82mm	30.00mm	M8 x 1.25	Full Thread	.0159 kg
3839	M	Steel	Bright Zinc	13.00mm	6.00mm	8.00mm	32.00mm	M8 x 1.25	20.00mm	.0200 kg
11-8535	M	Steel	Black Zinc	12.87mm	6.00mm	7.82mm	35.00mm	M8 x 1.25	Full Thread	.0172 kg
13-8535	M	Steel	Blue Zinc	12.87mm	6.00mm	7.82mm	35.00mm	M8 x 1.25	Full Thread	.0172 kg
17-8535	M	Stainless-Steel	Stainless	12.87mm	6.00mm	7.82mm	35.00mm	M8 x 1.25	Full Thread	.0172 kg
11-8540	M	Steel	Black Zinc	12.87mm	6.00mm	7.82mm	40.00mm	M8 x 1.25	28.00mm	.0191 kg
13-8540	M	Steel	Blue Zinc	12.87mm	6.00mm	7.82mm	40.00mm	M8 x 1.25	28.00mm	.0191 kg
13-3954	M	Steel	Blue Zinc	13.00mm	6.00mm	8.00mm	40.00mm	M8 x 1.25	28.00mm	.0242 kg
17-8540	M	Stainless-Steel	Stainless	12.87mm	6.00mm	7.82mm	40.00mm	M8 x 1.25	28.00mm	.0191 kg
13-3955	M	Steel	Blue Zinc	13.00mm	6.00mm	8.00mm	45.00mm	M8 x 1.25	28.00mm	.0211 kg
13-8550	M	Steel	Blue Zinc	12.87mm	6.00mm	7.82mm	50.00mm	M8 x 1.25	28.00mm	.0231 kg
13-3956	M	Steel	Blue Zinc	13.00mm	6.00mm	8.00mm	50.00mm	M8 x 1.25	28.00mm	.0233 kg
13-3957	M	Steel	Blue Zinc	13.00mm	6.00mm	8.00mm	60.00mm	M8 x 1.25	28.00mm	.0272 kg
13-3958	M	Steel	Blue Zinc	13.00mm	6.00mm	8.00mm	80.00mm	M8 x 1.25	28.00mm	.0349 kg
13-1520	M	Steel	Blue Zinc	15.87mm	8.00mm	9.82mm	20.00mm	M10 x 1.50	Full Thread	.0218 kg
13-1525	M	Steel	Blue Zinc	15.87mm	8.00mm	9.82mm	25.00mm	M10 x 1.50	Full Thread	.0240 kg

View page 389 for dimensional drawing



Low Head Socket Cap Screw / Flanged Hex Head Bolt

Low Head Socket Cap Screw (LHSCS)

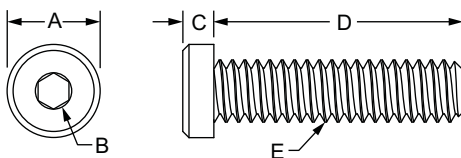

Black Zinc

Blue Zinc



Part No.	Series	Material	Finish	A	B	C	D (Length)	E (Thread)	Thread Length	Weight
3017	F	Steel	Black Zinc	.372"	1/8	.124"	1.000"	1/4-20	Full Thread	.013 lb
3018	F		Black Zinc	.434"	5/32	.155"	1.250"	5/16-18	Full Thread	.026 lb
13-1993	M		Blue Zinc	10.00mm	5.00mm	4.00mm	10.00mm	M6 x 1.0	Full Thread	.0036 kg
13-1957	M		Blue Zinc	13.00mm	6.00mm	5.00mm	16.00mm	M8 x 1.25	Full Thread	.0090 kg
11-2525	M		Black Zinc	18.00mm	8.00mm	8.00mm	25.00mm	M12 x 1.75	Full Thread	.0279 kg

Flanged Hex Head Bolt (FHFB)

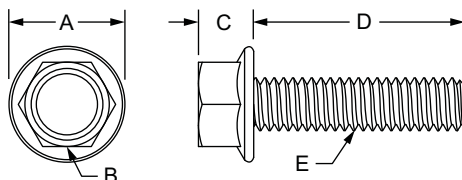

Bright Zinc



Part No.	Series	Material	Finish	A	B	C	D (Length)	E (Thread)	Thread Length	Weight
3747	F	Steel	Bright Zinc	.680"	1/2	.320"	.500"	5/16-18	Full Thread	.025 lb
3748	F			.680"	1/2	.320"	.750"	5/16-18	Full Thread	.027 lb
3749	F			.680"	1/2	.320"	1.000"	5/16-18	Full Thread	.029 lb
3750	F			.680"	1/2	.320"	1.250"	5/16-18	Full Thread	.038 lb
3751	F			.680"	1/2	.320"	1.500"	5/16-18	Full Thread	.043 lb
3752	F			.680"	1/2	.320"	1.750"	5/16-18	Full Thread	.044 lb
3753	F			.680"	1/2	.320"	2.000"	5/16-18	Full Thread	.049 lb
3754	F			.680"	1/2	.320"	2.250"	5/16-18	Full Thread	.052 lb
3755	F			.680"	1/2	.320"	3.500"	5/16-18	Full Thread	.075 lb
13-3753	M		Blue Zinc	17.40mm	12.00mm	8.10mm	50.00mm	M8 x 1.25	22.00mm	.0249 kg

Connecting Screw / Self Tapping Screw / Self Drilling Screw

Connecting Screws (CS)

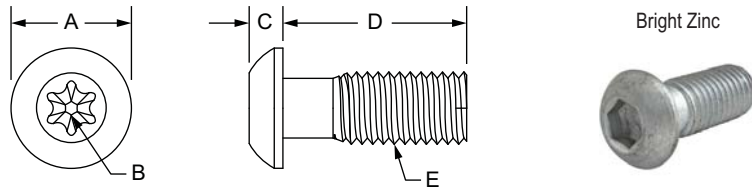

Part No.	Series	Material	Finish	A	B	C	D (Length)	E (Thread)	Thread Length	Weight
13003	M	Steel	Bright Zinc	19.50mm	8.00mm HEX	6.00mm	30.00mm	M12 x 1.75	23.00mm	.0277 kg
13006*	M			20.00mm	T-50	6.00mm	30.00mm	M10.6 x 1.5*	23.00mm	.0249 kg
13004	M			20.00mm	T-50	6.00mm	30.00mm	M12 x 1.75	22.25mm	.0281 kg

* Tri-Lobe Thread Forming Screw

Self Tapping Screw (STS)

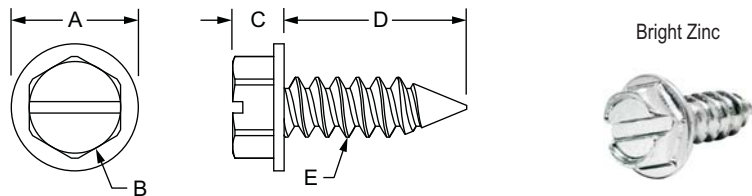

Part No.	Series	Material	Finish	A	B	C	D (Length)	E (Thread)	Weight
9320	F	Steel	Bright Zinc	.500"	1/4	.141"	.500"	#8-18	.003 lb
9301	F			.350"	1/4	.141"	.625"	#8-18	.003 lb
9306	F			.500"	3/8	.240"	.625"	1/4-14	.010 lb

Self Drilling Screw (SDS)

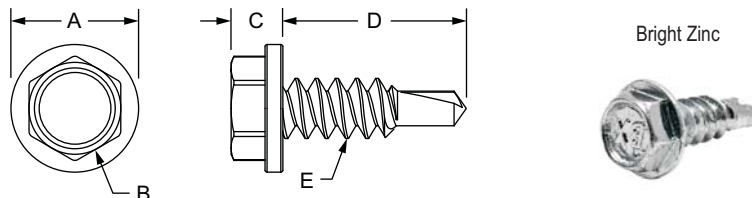

Part No.	Series	Material	Finish	A	B	C	D (Length)	E (Thread)	Weight
9325	F	Steel	Bright Zinc	.350"	1/4	.141"	.500"	#8-18	.003 lb
9302	F			.350"	1/4	.141"	.675"	#8-18	.003 lb
9307	F			.500"	3/8	.240"	.750"	1/4-14	.013 lb

Threaded Insert:

The threaded insert allows 45-series pivot joints to be mounted to a 45-series profile end. Use a 1/4 inch hex tool (see page 901).

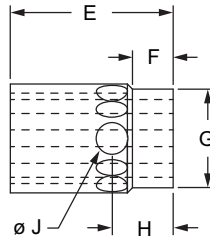
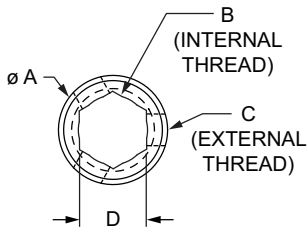

Part No.	Series	A	B (Thread)	C (Thread)	D	E (Length)	F	G	H	J	Weight
14196	M	10.70mm	M8 x 1.25	M10 x 1.5	6.60mm	16.00mm	4.00mm	9.70mm	6.00mm	3.10mm	.0039 kg

Material Specifications

Material	Finish	Process
Steel	Bright Zinc	Metal Forming

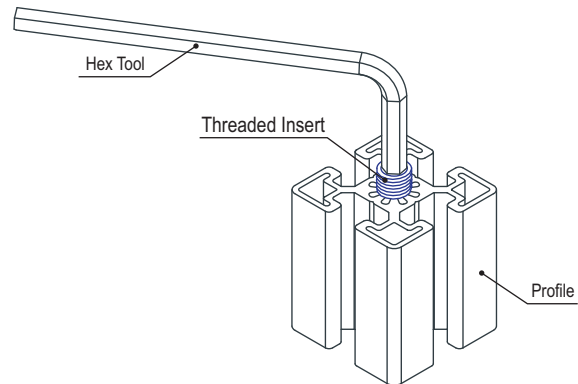
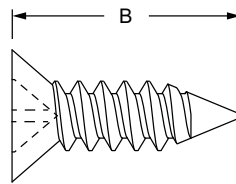
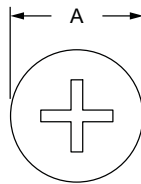
**Bearing Pad Screw**

Part No.	Series	Material	Finish	Process	A	B (Length)	Weight
3625	10	Stainless-Steel	Stainless	Formed	.332"	.375"	.001 lb
3626	10				.332"	.500"	.002 lb
3628	15				.362"	.625"	.003 lb
25-3625	25				8.43mm	9.53mm	.0008 kg
25-3626	25				8.43mm	12.70mm	.0012 kg
40-3629	40				8.43mm	6.35mm	.0020 kg
40-3628	40				9.19mm	15.88mm	.0015 kg

Shoulder Bolt

Shoulder Bolt

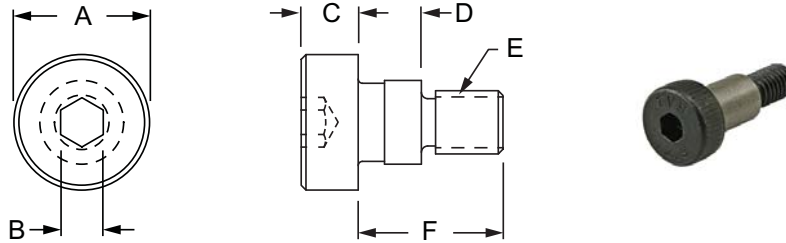

Part No.	Series	Material	Finish	A	B	C	D	E (Thread)	F	Weight
13-2247	M	Steel	Blue Zinc	13.00mm	4.00mm	5.50mm	6.00mm	M6 x 1.0	14.00mm	.0100 kg
13-1914	M			13.00mm	4.00mm	5.50mm	12.00mm	M6 x 1.0	23.25mm	.0116 kg
13-1922	M			16.00mm	5.00mm	7.00mm	20.00mm	M10 x 1.5	33.25mm	.0255 kg

Shoulder Bolt with Washer

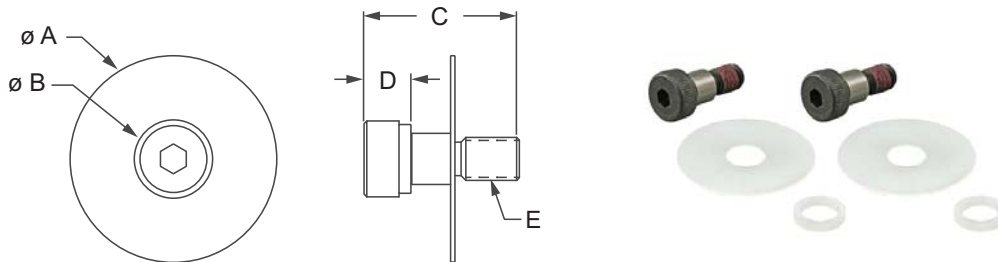

Part No.	Series	Bolt Material	Bolt Finish	Washer Material	Washer Finish	A	B	C	D	E (Thread)	Weight
3501	10	Steel	Blue Zinc	Plastic	White Nylon	1.000"	.435"	.759"	.246"	1/4-20	.073 lb
3500	15					1.500"	.552"	1.109"	.341"	5/16-18	.035 lb
25-3501	25					25.40mm	13.84mm	19.16mm	6.98mm	M6 X 1.0	.018 kg
40-3500	40					38.10mm	19.23mm	30.25mm	10.18mm	M8 X 1.25	.064 kg

*Assembly comprised of (2) Shoulder Bolts and (4) Plastic Washers

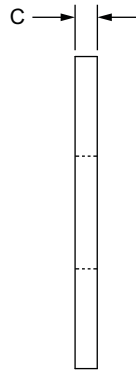
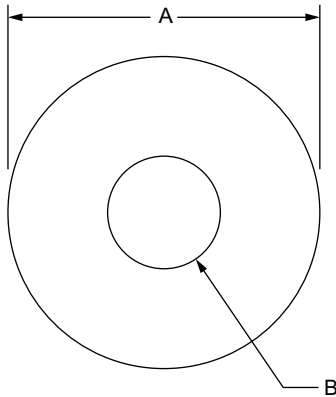

Part No.	Series	Material	Finish	Type	Mfg Standard	A	B	C	Weight
3006	F	Steel	Black Zinc	SAE Flat	ANSI B18.22.1	.438"	.188"	.049"	.001 lb
3055	F	Steel	Black Zinc	SAE Flat	ANSI B18.22.1	.505"	.221"	.051"	.002 lb
3258	F	Steel	Black Zinc	SAE Flat	ANSI B18.22.1	.625"	.286"	.066"	.004 lb
3260	F	Steel	Black Zinc	SAE Flat	ANSI B18.22.1	.692"	.349"	.066"	.004 lb
3261	F	Steel	Black Zinc	SAE Flat	ANSI B18.22.1	.816"	.410"	.066"	.006 lb
3262	F	Steel	Black Zinc	SAE Flat	ANSI B18.22.1	1.062"	.531"	.095"	.015 lb
3760	F	Steel	Bright Zinc	SAE Flat	ANSI B18.22.1	.692"	.349"	.066"	.006 lb
3762	F	Steel	Bright Zinc	SAE Flat	ANSI B18.22.1	1.000"	.449"	.068"	.013 lb
3764	F	Steel	Bright Zinc	SAE Flat	ANSI B18.22.1	1.387"	.567"	.109"	.038 lb
3658	F	Stainless-Steel	Stainless	SAE Flat	ANSI B18.22.1	.625"	.286"	.066"	.004 lb
3659	F	Stainless-Steel	Stainless	Standard Flat	ISO 7089	.692"	.345"	.045"	.004 lb
3861	F	Steel	Bright Zinc	Standard Flat	ISO 7089	.464"	.256"	.063"	.001 lb
3860	F	Steel	Bright Zinc	Standard Flat	ISO 7089	.621"	.335"	.063"	.003 lb
13-6040	M	Steel	Blue Zinc	Standard Flat	ISO 7089	9.82mm	5.39mm	1.00mm	.0004 kg
13-6041	M	Steel	Blue Zinc	Standard Flat	ISO 7089	11.78mm	6.51mm	1.60mm	.0008 kg
13-6045	M	Steel	Blue Zinc	Standard Flat	DIN 7349	13.00mm	6.87mm	2.70mm	.0022 kg
13-6042	M	Steel	Blue Zinc	Standard Flat	ISO 7089	15.78mm	8.51mm	1.60mm	.0018 kg
13-6043	M	Steel	Blue Zinc	Standard Flat	ISO 7089	19.74mm	10.63mm	2.00mm	.0033 kg
13-6044	M	Steel	Blue Zinc	Standard Flat	ISO 7089	26.25mm	14.25mm	4.00mm	.0109 kg
11-6039	M	Steel	Black Zinc	Standard Flat	ISO 7089	8.82mm	4.39mm	0.80mm	.0003 kg
11-6040	M	Steel	Black Zinc	Standard Flat	ISO 7089	9.60mm	5.30mm	1.00mm	.0004 kg
11-6041	M	Steel	Black Zinc	Standard Flat	ISO 7089	11.78mm	6.51mm	1.60mm	.0009 kg
11-6042	M	Steel	Black Zinc	Standard Flat	ISO 7089	15.78mm	8.51mm	1.60mm	.0013 kg
17-6041	M	Stainless-Steel	Stainless	Standard Flat	ISO 7089	11.78mm	6.51mm	1.60mm	.0009 kg
17-6042	M	Stainless-Steel	Stainless	Standard Flat	ISO 7089	15.78mm	8.51mm	1.60mm	.0013 kg
19-6041	M	Steel	Bright Zinc	Standard Flat	ISO 7089	11.78mm	6.51mm	1.60mm	.0009 kg
19-6042	M	Steel	Bright Zinc	Standard Flat	ISO 7089	15.78mm	8.51mm	1.60mm	.0018 kg
25-3502	M	Plastic	White Nylon	—	—	13.84mm	9.22mm	1.27mm	.0001 kg
25-3503	M	Plastic	White Nylon	—	—	13.84mm	9.22mm	2.01mm	.0002 kg
40-3503	M	Plastic	White Nylon	—	—	19.48mm	10.26mm	4.01mm	.0009 kg
65-3258	M	Steel	Black Zinc	SAE Flat	ANSI B18.22.1	16.00mm	7.40mm	1.52mm	.0015 kg
65-3260	M	Steel	Black Zinc	SAE Flat	ANSI B18.22.1	17.35mm	8.86mm	1.66mm	.0018 kg

Hex Nut

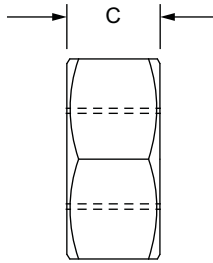
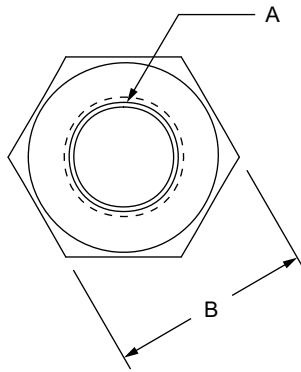

Part No.	Series	Material	Finish	Type	Mfg Standard	A (Thread)	B	C	Weight
3007	F	Steel	Black Zinc	Finished Hex Nut	ANSI/ASME B18.2.2	8-32	.338"	.123"	.002 lb
3053	F	Steel	Black Zinc	Machine Screw	ANSI/ASME B18.6.3	10-32	.368"	.123"	.003 lb
3208	F	Steel	Black Zinc	Finished Hex Nut	ANSI/ASME B18.2.2	1/4-20	.433"	.219"	.007 lb
3214	F	Steel	Black Zinc	Finished Hex Nut	ANSI/ASME B18.2.2	5/16-18	.494"	.265"	.010 lb
3215	F	Steel	Black Zinc	Finished Hex Nut	ANSI/ASME B18.2.2	3/8 - 16	.563"	.328"	.015 lb
3714	F	Steel	Bright Zinc	Finished Hex Nut	ANSI/ASME B18.2.2	5/16-18	.494"	.265"	.010 lb
3707	F	Steel	Bright Zinc	Finished Hex Nut	ANSI/ASME B18.2.2	3/8-24	.556"	.328"	.015 lb
3709	F	Steel	Bright Zinc	Finished Hex Nut	ANSI/ASME B18.2.2	1/2-13	.743"	.437"	.035 lb
3656	F	Stainless-Steel	Stainless	Finished Hex Nut	ANSI/ASME B18.2.2	1/4-20	.433"	.219"	.007 lb
3657	F	Stainless-Steel	Stainless	Finished Hex Nut	ANSI/ASME B18.2.2	5/16-18	.494"	.265"	.010 lb
3820	F	Steel	Bright Zinc	Hex Nut	DIN 934	M6 x 1.0	.389"	.191"	.005 lb
3821	F	Steel	Bright Zinc	Hex Nut	DIN 934	M8 x 1.25	.506"	.248"	.010 lb
13-5065	M	Steel	Blue Zinc	Hex Nut	DIN 934	M5 x 0.8	7.89mm	3.95mm	.0010 kg
13-6065	M	Steel	Blue Zinc	Hex Nut	DIN 934	M6 x 1.0	9.89mm	4.85mm	.0022 kg
13-8065	M	Steel	Blue Zinc	Hex Nut	DIN 934	M8 x 1.25	12.86mm	6.32mm	.0045 kg
13-2065	M	Steel	Blue Zinc	Hex Nut	ISO 4033	M12 x 1.75	17.86mm	11.78mm	.0086 kg
11-4065	M	Steel	Black Zinc	Hex Nut	DIN 934	M4 x 0.7	6.89mm	3.10mm	.0007 kg
11-5065	M	Steel	Black Zinc	Hex Nut	DIN 934	M5 x 0.8	7.89mm	3.85mm	.0010 kg
11-6065	M	Steel	Black Zinc	Hex Nut	DIN 934	M6 x 1.0	9.89mm	4.85mm	.0022 kg
11-8065	M	Steel	Black Zinc	Hex Nut	DIN 934	M8 x 1.25	12.86mm	6.32mm	.0045 kg
17-6065	M	Stainless-Steel	Stainless	Hex Nut	DIN 934	M6 x 1.0	9.89mm	4.85mm	.0022 kg
17-1065	M	Stainless-Steel	Stainless	Hex Nut	DIN 934	M10 x 1.5	16.87mm	7.82mm	.0104 kg
19-6065	M	Steel	Bright Zinc	Hex Nut	DIN 934	M6 x 1.0	9.89mm	4.85mm	.0022 kg
19-8065	M	Steel	Bright Zinc	Hex Nut	DIN 934	M8 x 1.25	12.86mm	6.32mm	.0045 kg
19-1065	M	Steel	Bright Zinc	Hex Nut	DIN 934	M10 x 1.5	16.87mm	7.82mm	.0104 kg
19-2065	M	Steel	Bright Zinc	Hex Nut	DIN 934	M12 x 1.75	19.00mm	10.00mm	.0151 kg
65-3208	M	Steel	Black Zinc	Finished Hex Nut	ANSI/ASME B18.2.2	1/4-20	10.90mm	5.45mm	.0031 kg
65-3214	M	Steel	Black Zinc	Finished Hex Nut	ANSI/ASME B18.2.2	5/16-18	12.50mm	6.70mm	.0045 kg

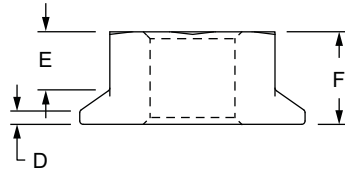
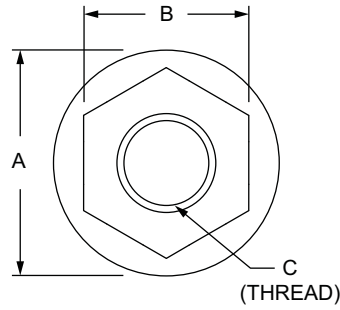

Part No.	Series	Material	Grade	Finish	Nylock	A	B	C (Thread)	D	E	F	Weight
3758	F RT	Steel	Class 8	Bright Zinc	Yes	.670"	.500"	5/16-18	.040"	.170"	.275"	.013 lb
3759	F RT			Bright Zinc	No	.670"	.500"	5/16-18	.040"	.170"	.275"	.013 lb
14156	M			Blue Zinc	No	14.20mm	10.00mm	M6 x 1.0	1.10mm	3.10mm	6.00mm	.0034 kg
13-3758	M RT			Bright Zinc	Yes	17.90mm	13.00mm	M8 x 1.25	1.20mm	4.50mm	8.00mm	.0071 kg
13-3759	M RT			Blue Zinc	No	17.90mm	13.00mm	M8 x 1.25	1.20mm	4.50mm	8.00mm	.0073 kg

Slide-In Flanged Economy T-Slot Stud

80/20[®] Inc.

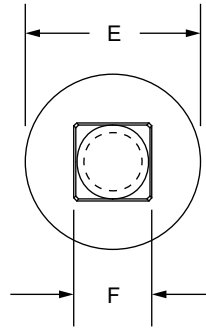
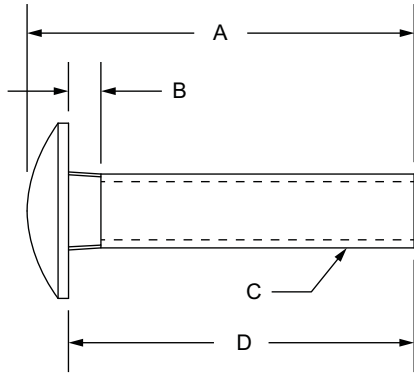

Part No.	Series	Material	Finish	A	B	C (Thread)	D (Length)	E	F	Weight
3115	10	Steel	Black Zinc	.875"	.140"	1/4-20	.750"	.500"	.235"	.013 lb
3116	15	Steel	Black Zinc	.898"	.135"	5/16-18	.750"	.700"	.308"	.025 lb
3851	15	Steel	Bright Zinc	.945"	.135"	M8 x 1.25	.787"	.700"	.308"	.027 lb
3120	15	Steel	Black Zinc	1.153"	.135"	5/16-18	1.000"	.700"	.308"	.031 lb
3852	15	Steel	Bright Zinc	1.145"	.135"	M8 x 1.25	.984"	.700"	.308"	.030 lb
3126	15	Steel	Black Zinc	1.405"	.135"	5/16-18	1.250"	.700"	.308"	.034 lb
3853	15	Steel	Bright Zinc	1.350"	.135"	M8 x 1.25	1.181"	.700"	.308"	.033 lb
3134	15	Steel	Black Zinc	1.650"	.135"	5/16-18	1.500"	.700"	.308"	.037 lb
3854	15	Steel	Bright Zinc	1.530"	.135"	M8 x 1.25	1.378"	.700"	.308"	.038 lb
3288	15	Steel	Black Zinc	1.905"	.135"	5/16-18	1.750"	.700"	.308"	.042 lb
3857	15	Steel	Bright Zinc	1.920"	.135"	M8 x 1.25	1.772"	.700"	.308"	.045 lb
3290	15	Steel	Black Zinc	2.145"	.135"	5/16-18	2.000"	.700"	.308"	.046 lb
19-8920	40	Steel	Bright Zinc	23.90mm	3.50mm	M8 x 1.25	20.00mm	17.75mm	7.80mm	.0126 kg
19-8925	40	Steel	Bright Zinc	29.00mm	3.50mm	M8 x 1.25	25.00mm	17.75mm	7.80mm	.0137 kg
19-8930	40	Steel	Bright Zinc	34.50mm	3.50mm	M8 x 1.25	30.00mm	17.75mm	7.80mm	.0149 kg
19-8935	40	Steel	Bright Zinc	38.90mm	3.50mm	M8 x 1.25	35.00mm	17.75mm	7.80mm	.0172 kg
19-8945	40	Steel	Bright Zinc	49.00mm	3.50mm	M8 x 1.25	45.00mm	17.75mm	7.80mm	.0202 kg
40-3116	40	Steel	Black Zinc	22.75mm	3.50mm	5/16-18	19.05mm	17.75mm	7.80mm	.0116 kg
40-3120	40	Steel	Black Zinc	29.00mm	3.50mm	5/16-18	25.40mm	17.75mm	7.80mm	.0134 kg
40-3126	40	Steel	Black Zinc	35.75mm	3.50mm	5/16-18	31.75mm	17.75mm	7.80mm	.0149 kg
40-3134	40	Steel	Black Zinc	42.00mm	3.50mm	5/16-18	38.10mm	17.75mm	7.80mm	.0172 kg
40-3290	40	Steel	Black Zinc	54.75mm	3.50mm	5/16-18	50.80mm	17.75mm	7.80mm	.0209 kg

45
45 Series**40**
40 Series**30**
30 Series**M**
Metric**15**
15 Series**F**
Fractional

Fastening Methods

Drop-In T-Slot Stud Assembly

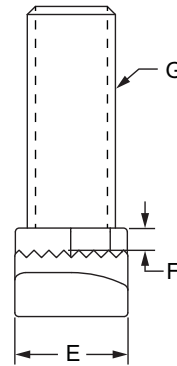
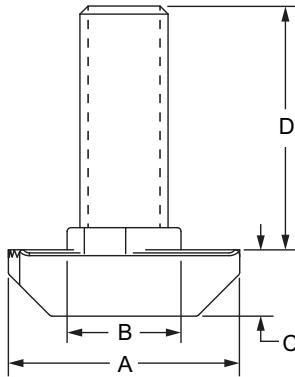

Part No.	Series	Material	Finish	A	B	C	D (Length)	E	F	G (Thread)	Weight
13135	30	Stainless-Steel	Stainless	16.00mm	7.70mm	4.50mm	20.00mm	7.70mm	1.50mm	M6 x 1.0	.0076 kg
13137	30	Stainless-Steel	Stainless	16.00mm	7.70mm	4.50mm	25.00mm	7.70mm	1.50mm	M6 x 1.0	.0082 kg
13139	30	Stainless-Steel	Stainless	16.00mm	7.70mm	4.50mm	30.00mm	7.70mm	1.50mm	M6 x 1.0	.0095 kg
13141	30	Stainless-Steel	Stainless	16.00mm	7.70mm	4.50mm	40.00mm	7.70mm	1.50mm	M6 x 1.0	.0112 kg
13143	30	Stainless-Steel	Stainless	16.00mm	7.70mm	4.50mm	60.00mm	7.70mm	1.50mm	M6 x 1.0	.0147 kg
13134	30	Steel	Bright Zinc	16.00mm	7.70mm	4.50mm	20.00mm	7.70mm	1.50mm	M6 x 1.0	.0073 kg
13136	30	Steel	Bright Zinc	16.00mm	7.70mm	4.50mm	25.00mm	7.70mm	1.50mm	M6 x 1.0	.0078 kg
13138	30	Steel	Bright Zinc	16.00mm	7.70mm	4.50mm	30.00mm	7.70mm	1.50mm	M6 x 1.0	.0093 kg
13140	30	Steel	Bright Zinc	16.00mm	7.70mm	4.50mm	40.00mm	7.70mm	1.50mm	M6 x 1.0	.0104 kg
13142	30	Steel	Bright Zinc	16.00mm	7.70mm	4.50mm	60.00mm	7.70mm	1.50mm	M6 x 1.0	.0138 kg
13144	15 40	Steel	Bright Zinc	15.75mm	7.75mm	4.50mm	20.00mm	7.80mm	3.00mm	M6 x 1.0	.0075 kg
13145	15 40	Steel	Bright Zinc	15.75mm	7.75mm	4.50mm	25.00mm	7.80mm	3.00mm	M6 x 1.0	.0083 kg
13146	15 40	Steel	Bright Zinc	15.75mm	7.75mm	4.50mm	30.00mm	7.80mm	3.00mm	M6 x 1.0	.0093 kg
13147	15 40	Steel	Bright Zinc	15.75mm	7.75mm	4.50mm	40.00mm	7.80mm	3.00mm	M6 x 1.0	.0108 kg
13148	15 40	Steel	Bright Zinc	15.75mm	7.75mm	4.50mm	60.00mm	7.80mm	3.00mm	M6 x 1.0	.0147 kg
13169	45	Steel	Bright Zinc	19.00mm	9.70mm	5.80mm	20.00mm	9.70mm	3.00mm	M8 x 1.25	.0132 kg
13171	45	Steel	Bright Zinc	19.00mm	9.70mm	5.80mm	25.00mm	9.70mm	3.00mm	M8 x 1.25	.0146 kg
13173	45	Steel	Bright Zinc	19.00mm	9.70mm	5.80mm	30.00mm	9.70mm	3.00mm	M8 x 1.25	.0159 kg
13175	45	Steel	Bright Zinc	19.00mm	9.70mm	5.80mm	40.00mm	9.70mm	3.00mm	M8 x 1.25	.0187 kg
13177	45	Steel	Bright Zinc	19.00mm	9.70mm	5.80mm	60.00mm	9.70mm	3.00mm	M8 x 1.25	.0253 kg
13170	45	Stainless-Steel	Stainless	19.00mm	9.70mm	5.80mm	20.00mm	9.70mm	3.00mm	M8 x 1.25	.0136 kg
13172	45	Stainless-Steel	Stainless	19.00mm	9.70mm	5.80mm	25.00mm	9.70mm	3.00mm	M8 x 1.25	.0106 kg
13174	45	Stainless-Steel	Stainless	19.00mm	9.70mm	5.80mm	30.00mm	9.70mm	3.00mm	M8 x 1.25	.0154 kg
13176	45	Stainless-Steel	Stainless	19.00mm	9.70mm	5.80mm	40.00mm	9.70mm	3.00mm	M8 x 1.25	.0191 kg
13178	45	Stainless-Steel	Stainless	19.00mm	9.70mm	5.80mm	60.00mm	9.70mm	3.00mm	M8 x 1.25	.0258 kg

FASTENERS

Drop-In T-Slot Stud

FASTENERS

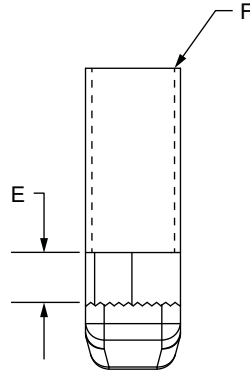
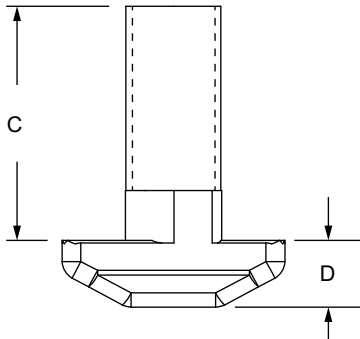
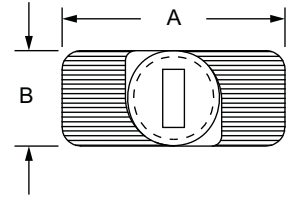

Part No.	Series	Material	Finish	A	B	C (Length)	D	E	F (Thread)	Weight
3293	15	Steel	Black Zinc	.713"	.305"	.750"	.213"	.160"	5/16-18	.024 lb
3295	15			.713"	.305"	1.000"	.213"	.160"	5/16-18	.027 lb
3297	15			.713"	.305"	1.250"	.213"	.160"	5/16-18	.032 lb
3299	15			.713"	.305"	1.500"	.213"	.160"	5/16-18	.036 lb

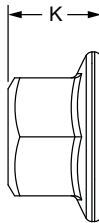
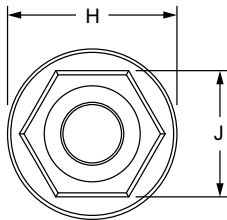
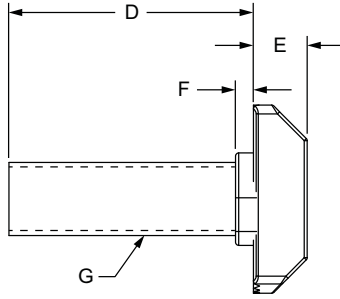
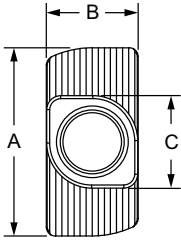

Part No.	Series	Material	Finish	A	B	C	D	E	F	G	H	J	K	Weight
75-3633	30	Steel	Bright / Blue Zinc	15.75mm	7.75mm	7.80mm	20.00mm	4.50mm	1.50mm	M6 x 1.0	14.20mm	9.89mm	5.85mm	.0104 kg
75-3636	30			16.00mm	7.70mm	7.70mm	25.00mm	4.50mm	1.50mm	M6 x 1.0	14.20mm	9.89mm	5.85mm	.0109 kg
75-3637	30			16.00mm	7.70mm	7.70mm	30.00mm	4.50mm	1.50mm	M6 x 1.0	14.20mm	9.89mm	5.85mm	.0123 kg
75-3632	45			19.00mm	9.70mm	9.70mm	20.00mm	5.80mm	3.00mm	M8 x 1.25	17.90mm	13.00mm	7.80mm	.0203 kg
75-3635	45			19.00mm	9.70mm	9.70mm	25.00mm	5.80mm	3.00mm	M8 x 1.25	17.90mm	13.00mm	7.80mm	.0260 kg
75-3638	45			19.00mm	9.70mm	9.70mm	30.00mm	5.80mm	3.00mm	M8 x 1.25	17.90mm	13.00mm	7.80mm	.0072 kg

Slide-In Economy T-Slot Stud

80/20[®] Inc.

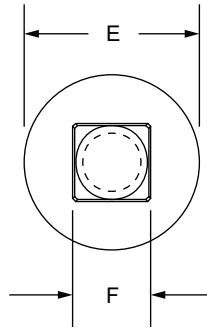
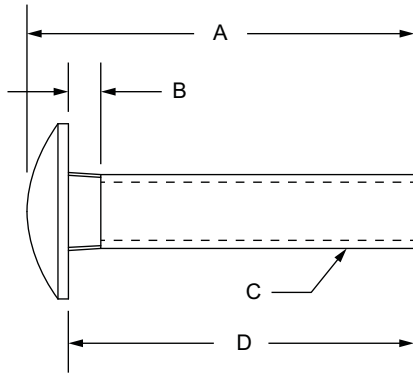

Part No.	Series	Material	Finish	A	B	C (Thread)	D (Length)	E	F	Weight
3716	15	Steel	Bright Zinc	.910"	.160"	5/16-18	.750"	.695"	.310"	.026 lb
3720	15			1.160"	.160"	5/16-18	1.000"	.695"	.310"	.029 lb

1/4-20 Button Head Socket Cap Screw (BHSCS)

Assy. No.	Bolt	Qty.	Bolt Type	Thread Size	Bolt Length	Nut	Qty.	Nut Type	Washer	Qty.	Weight
3520	3059	1	BHSCS	1/4-20	.375"	3376	1	Roll-In T-Nut with Flex Handle	—	—	.015 lb
3416	3059	1			.375"	3382	1	Slide-In Economy T-Nut - Centered Thread	—	—	.026 lb
3394	3061	1			.500"	3376	1	Roll-In T-Nut with Flex Handle	—	—	.021 lb
3399	3061	1			.500"	3376	1	Roll-In T-Nut with Flex Handle	3258	1	.020 lb
75-3801	3061	1			.500"	3376	1	Roll-In T-Nut with Flex Handle	—	—	.016 lb
75-3807	3061	1			.500"	3376	1	Roll-In T-Nut with Flex Handle	3258	1	.020 lb
3521	3061	1			.500"	3376	1	Roll-In T-Nut with Flex Handle	—	—	.016 lb
3393	3061	1			.500"	3382	1	Slide-In Economy T-Nut - Centered Thread	—	—	.017 lb
3398	3061	1			.500"	3382	1	Slide-In Economy T-Nut - Centered Thread	3258	1	.021 lb
75-3800	3061	1			.500"	3382	1	Slide-In Economy T-Nut - Centered Thread	—	—	.017 lb
75-3806	3061	1			.500"	3382	1	Slide-In Economy T-Nut - Centered Thread	3258	1	.021 lb
3408	3061	1			.500"	14165	1	Standard Drop-In T-Nut	—	—	.016 lb
3484	3063	1			.625"	3376	1	Roll-In T-Nut with Flex Handle	3258	1	.020 lb
75-3803	3063	1			.625"	3376	1	Roll-In T-Nut with Flex Handle	—	—	.017 lb
75-3809	3063	1			.625"	3376	1	Roll-In T-Nut with Flex Handle	3258	1	.020 lb
3522	3063	1			.625"	3376	1	Roll-In T-Nut with Flex Handle	—	—	.018 lb
3418	3063	1			.625"	3286	1	Slide-In Economy T-Nut - Centered Thread	—	—	.018 lb
3482	3063	1			.625"	3382	1	Slide-In Economy T-Nut - Centered Thread	3258	1	.022 lb
3647*	3663	1			.625"	3686	1	Slide-In Economy T-Nut - Centered Thread	3658	1	.025 lb
75-3802	3063	1			.625"	3382	1	Slide-In Economy T-Nut - Centered Thread	—	—	.018 lb
75-3808	3063	1			.625"	3382	1	Slide-In Economy T-Nut - Centered Thread	3258	1	.022 lb
3367	3063	1			.625"	—	—	—	3258	1	.012 lb
3469	3065	1			.750"	3208	1	Hex Nut	3258	1	.020 lb
3372	3065	1			.750"	3376	1	Roll-In T-Nut with Flex Handle	3258	1	.021 lb
75-3805	3065	1			.750"	3376	1	Roll-In T-Nut with Flex Handle	—	—	.019 lb
75-3811	3065	1			.750"	3376	1	Roll-In T-Nut with Flex Handle	3258	1	.021 lb
3523	3065	1			.750"	3376	1	Roll-In T-Nut with Flex Handle	—	—	.018 lb
3371	3065	1			.750"	3382	1	Slide-In Economy T-Nut - Centered Thread	3258	1	.036 lb
75-3804	3065	1			.750"	3382	1	Slide-In Economy T-Nut - Centered Thread	—	—	.020 lb
75-3810	3065	1			.750"	3382	1	Slide-In Economy T-Nut - Centered Thread	3258	1	.023 lb
3479	3065	1			.750"	3204	1	Standard Slide-In T-Nut	—	—	.018 lb
3388	3065	1			.750"	—	—	—	3258	1	.014 lb

*Assembly comprised of stainless steel (SS) hardware

CONTINUE

Bolt Assemblies (Continued)

1/4-20 Flanged Button Head Socket Cap Screw (FBHSCS)

Assy. No.	Bolt	Qty.	Bolt Type	Thread Size	Bolt Length	Nut	Qty.	Nut Type	Washer	Qty.	Weight
3002	3390	2	FBHSCS	1/4-20	.375"	3280	1	Double Slide-In Economy T-Nut	—	—	.034 lb
3387	3390	1			Roll-In T-Nut with Flex Handle	—	—	.015 lb			
3480	3390	1			Roll-In T-Nut with Flex Handle	—	—	.015 lb			
3386	3390	1			Slide-In Economy T-Nut - Centered Thread	—	—	.016 lb			
3356	3342	2			Double Slide-In Economy T-Nut	—	—	.037 lb			
3465	3342	1			Hex Nut	—	—	.016 lb			
3481	3342	1			Roll-In T-Nut with Flex Handle	—	—	.017 lb			
3322	3342	1			Roll-In T-Nut with Flex Handle	—	—	.033 lb			
3321	3342	1			Slide-In Economy T-Nut - Centered Thread	—	—	.018 lb			
3358	3342	3			Triple Slide-In Economy T-Nut	—	—	.052 lb			
3004	3066	1			Hex Nut	3258	1	.022 lb			
3385	3066	1			Roll-In T-Nut with Flex Handle	—	—	.037 lb			
3485	3066	1			Roll-In T-Nut with Flex Handle	—	—	.019 lb			
3384	3066	1			Slide-In Economy T-Nut - Centered Thread	—	—	.020 lb			

1/4-20 Flat Head Socket Cap Screw (FHSCS)

Assy. No.	Bolt	Qty.	Bolt Type	Thread Size	Bolt Length	Nut	Qty.	Nut Type	Washer	Qty.	Weight
3415	3400	1	FHSCS	1/4-20	.500"	3376	1	Roll-In T-Nut with Flex Handle	—	—	.016 lb
3639*	3645	1			Roll-In T-Nut with Flex Handle	—	—	.016 lb			
3533	3400	1			Roll-In T-Nut with Flex Handle	—	—	.028 lb			
3532	3400	1			Roll-In T-Nut with Flex Handle	—	—	.032 lb			
3414	3400	1			Slide-In Economy T-Nut - Centered Thread	—	—	.018 lb			
3419	3400	1			Standard Slide-In T-Nut	—	—	.019 lb			
3524	3405	1			Roll-In T-Nut with Flex Handle	—	—	.017 lb			
3409	3405	1			Standard Drop-In T-Nut	—	—	.017 lb			
3417	3406	1			Hex Nut	3258	1	.022 lb			
3525	3406	1			Roll-In T-Nut with Flex Handle	—	—	.019 lb			
3534	3406	1			Roll-In T-Nut with Flex Handle	—	—	.029 lb			
3407	3406	1			Standard Drop-In T-Nut	—	—	.019 lb			

*Assembly comprised of stainless steel (SS) hardware

1/4-20 Socket Head Cap Screw (SHCS)

Assy. No.	Bolt	Qty.	Bolt Type	Thread Size	Bolt Length	Nut	Qty.	Nut Type	Washer	Qty.	Weight
3490	3058	1	SHCS	1/4-20	.375"	3376	1	Roll-In T-Nut with Flex Handle	—	—	.017 lb
3486	3058	1			Slide-In Economy T-Nut - Centered Thread	—	—	.019 lb			
3492	3062	1			Roll-In T-Nut with Flex Handle	—	—	.018 lb			
3496	3062	1			Roll-In T-Nut with Flex Handle	3258	1	.022 lb			
75-3813	3062	1			Roll-In T-Nut with Flex Handle	—	—	.018 lb			
75-3821	3062	1			Roll-In T-Nut with Flex Handle	3258	1	.022 lb			
3491	3062	1			Slide-In Economy T-Nut - Centered Thread	—	—	.020 lb			
3495	3062	1			Slide-In Economy T-Nut - Centered Thread	3258	1	.024 lb			
75-3812	3062	1			Slide-In Economy T-Nut - Centered Thread	—	—	.020 lb			
75-3820	3062	1			Slide-In Economy T-Nut - Centered Thread	3258	1	.024 lb			
3494	3067	1			Roll-In T-Nut with Flex Handle	—	—	.020 lb			
3498	3067	1			Roll-In T-Nut with Flex Handle	3258	1	.023 lb			

CONTINUE 

1/4-20 Socket Head Cap Screw (SHCS)

Assy. No.	Bolt	Qty.	Bolt Type	Thread Size	Bolt Length	Nut	Qty.	Nut Type	Washer	Qty.	Weight
75-3815	3067	1	SHCS	1/4-20	.625"	3376	1	Roll-In T-Nut with Flex Handle	—	—	.020 lb
75-3823	3067	1			.625"	3376	1	Roll-In T-Nut with Flex Handle	3258	1	.023 lb
3493	3067	1			.625"	3382	1	Slide-In Economy T-Nut - Centered Thread	—	—	.021 lb
3497	3067	1			.625"	3382	1	Slide-In Economy T-Nut - Centered Thread	3258	1	.025 lb
75-3814	3067	1			.625"	3382	1	Slide-In Economy T-Nut - Centered Thread	—	—	.021 lb
75-3822	3067	1			.625"	3382	1	Slide-In Economy T-Nut - Centered Thread	3258	1	.025 lb
3397	3064	1			.750"	3376	1	Roll-In T-Nut with Flex Handle	—	—	.021 lb
75-3817	3064	1			.750"	3376	1	Roll-In T-Nut with Flex Handle	—	—	.021 lb
75-3825	3064	1			.750"	3376	1	Roll-In T-Nut with Flex Handle	3258	1	.024 lb
3304	3064	1			.750"	3382	1	Slide-In Economy T-Nut - Centered Thread	—	—	.025 lb
75-3816	3064	1			.750"	3382	1	Slide-In Economy T-Nut - Centered Thread	—	—	.025 lb
75-3824	3064	1			.750"	3382	1	Slide-In Economy T-Nut - Centered Thread	3258	1	.026 lb
3315	3068	1			.875"	3208	1	Hex Nut	3258	1	.025 lb
3305	3068	1			.875"	3382	1	Slide-In Economy T-Nut - Centered Thread	—	—	.024 lb
3471	3068	1			.875"	3382	1	Slide-In Economy T-Nut - Centered Thread	3258	1	.027 lb
75-3819	3071	1			1.000"	3376	1	Roll-In T-Nut with Flex Handle	—	—	.023 lb
3306	3071	1			1.000"	3382	1	Slide-In Economy T-Nut - Centered Thread	—	—	.025 lb
75-3818	3071	1			1.000"	3382	1	Slide-In Economy T-Nut - Centered Thread	—	—	.025 lb
3307	3072	1			1.250"	3382	1	Slide-In Economy T-Nut - Centered Thread	—	—	.027 lb
3308	3080	1			1.500"	3382	1	Slide-In Economy T-Nut - Centered Thread	—	—	.041 lb
3432	3080	1			1.500"	3382	1	Slide-In Economy T-Nut - Centered Thread	3258	1	.020 lb
3433	3081	1			2.125"	3382	1	Slide-In Economy T-Nut - Centered Thread	3258	1	.027 lb
3434	3082	1			2.500"	3382	1	Slide-In Economy T-Nut - Centered Thread	—	—	.044 lb

FASTENERS

5/16-18 Button Head Socket Cap Screw (BHSCS)

Assy. No.	Bolt	Qty.	Bolt Type	Thread Size	Bolt Length	Nut	Qty.	Nut Type	Washer	Qty.	Weight
3526	3104	1	BHSCS	5/16-18	.500"	3282	1	Roll-In T-Nut with Flex Handle	—	—	.036 lb
3437	3111	1			.625"	3282	1	Roll-In T-Nut with Flex Handle	3260	1	.043 lb
3618*	3611	1			.625"	3600	1	Roll-In T-Nut with Flex Handle	3659	1	.042 lb
75-3827	3111	1			.625"	3282	1	Roll-In T-Nut with Flex Handle	—	—	.038 lb
75-3833	3111	1			.625"	3282	1	Roll-In T-Nut with Flex Handle	3260	1	.043 lb
3527	3111	1			.625"	3282	1	Roll-In T-Nut with Flex Handle	—	—	.038 lb
3365	3111	1			.625"	3278	1	Slide-In Economy T-Nut - Offset Thread	—	—	.041 lb
3435	3111	1			.625"	3278	1	Slide-In Economy T-Nut - Offset Thread	3260	1	.045 lb
3461	3111	1			.625"	3278	1	Slide-In Economy T-Nut - Offset Thread	—	—	.041 lb
3620*	3611	1			.625"	3678	1	Slide-In Economy T-Nut - Offset Thread	3659	1	.047 lb
75-3826	3111	1			.625"	3278	1	Slide-In Economy T-Nut - Offset Thread	—	—	.041 lb
75-3832	3111	1			.625"	3278	1	Slide-In Economy T-Nut - Offset Thread	3260	1	.045 lb
3442	3114	1			.750"	3214	1	Hex Nut	3260	1	.033 lb
3467	3114	1			.750"	3214	1	Hex Nut	3260	1	.033 lb
3441	3114	1			.750"	3282	1	Roll-In T-Nut with Flex Handle	3260	1	.044 lb
75-3829	3114	1			.750"	3282	1	Roll-In T-Nut with Flex Handle	—	—	.040 lb
75-3835	3114	1			.750"	3282	1	Roll-In T-Nut with Flex Handle	3260	1	.044 lb
3528	3114	1			.750"	3282	1	Roll-In T-Nut with Flex Handle	—	—	.040 lb

*Assembly comprised of stainless steel (SS) hardware

CONTINUE

Bolt Assemblies (Continued)

5/16-18 Button Head Socket Cap Screw (BHSCS)

Assy. No.	Bolt	Qty.	Bolt Type	Thread Size	Bolt Length	Nut	Qty.	Nut Type	Washer	Qty.	Weight
3439	3114	1	BHSCS	5/16-18	.750"	3278	1	Slide-In Economy T-Nut - Offset Thread	3260	1	.043 lb
3630*	3614	1			.750"	3678	1	Slide-In Economy T-Nut - Offset Thread	3659	1	.050 lb
75-3828	3114	1			.750"	3278	1	Slide-In Economy T-Nut - Offset Thread	—	—	.039 lb
75-3834	3114	1			.750"	3278	1	Slide-In Economy T-Nut - Offset Thread	3260	1	.043 lb
3366	3114	1			.750"	—	—	—	3260	1	.023 lb
3499	3117	1			.875"	—	—	—	3260	1	.024 lb
3445	3118	1			1.000"	3282	1	Roll-In T-Nut with Flex Handle	3260	1	.048 lb
75-3831	3118	1			1.000"	3282	1	Roll-In T-Nut with Flex Handle	—	—	.044 lb
75-3837	3118	1			1.000"	3282	1	Roll-In T-Nut with Flex Handle	3260	1	.048 lb
3443	3118	1			1.000"	3278	1	Slide-In Economy T-Nut - Offset Thread	3260	1	.046 lb
3632*	3621	1			1.000"	3678	1	Slide-In Economy T-Nut - Offset Thread	3659	1	.054 lb
75-3830	3118	1			1.000"	3278	1	Slide-In Economy T-Nut - Offset Thread	—	—	.042 lb
75-3836	3118	1			1.000"	3278	1	Slide-In Economy T-Nut - Offset Thread	3260	1	.046 lb
3971	3945	1			1.750"	3759	1	Flanged Hex Nut	3760	1	.054 lb
3961	3946	1			2.000"	3759	1	Flanged Hex Nut	3760	1	.058 lb

*Assembly comprised of stainless steel (SS) hardware

5/16-18 Drop-in T-Slot Stud

Assy. No.	Bolt	Qty.	Bolt Type	Thread Size	Bolt Length	Nut	Qty.	Nut Type	Washer	Qty.	Weight
3300	3293	1	Drop-in T-Slot Stud	5/16-18	.750"	3214	1	Hex Nut	3260	1	.038 lb
3476	3293	1			.750"	3214	1		3260	1	.038 lb
3301	3295	1			1.000"	3214	1		3260	1	.041 lb
3478	3295	1			1.000"	3214	1		3260	1	.041 lb
3302	3297	1			1.250"	3214	1		3260	1	.046 lb
3303	3299	1			1.500"	3214	1		3260	1	.050 lb

5/16-18 Flat Head Socket Cap Screw (FHSCS)

Assy. No.	Bolt	Qty.	Bolt Type	Thread Size	Bolt Length	Nut	Qty.	Nut Type	Washer	Qty.	Weight
3529	3011	1	FHSCS	5/16-18	.500"	3282	1	Roll-In T-Nut with Flex Handle	—	—	.036 lb
3530	3410	1			.625"	3282	1	Roll-In T-Nut with Flex Handle	—	—	.038 lb
3531	3411	1			.750"	3282	1	Roll-In T-Nut with Flex Handle	—	—	.041 lb
3412	3410	1			.625"	3278	1	Slide-In Economy T-Nut - Offset Thread	—	—	.0361 lb

5/16-18 Flanged Button Head Socket Cap Screw (FBHSCS)

Assy. No.	Bolt	Qty.	Bolt Type	Thread Size	Bolt Length	Nut	Qty.	Nut Type	Washer	Qty.	Weight
3000	3340	2	FBHSCS	5/16-18	.500"	3279	1	Double Slide-In Economy T-Nut	—	—	.094 lb
3318	3340	1			.500"	3282	1	Roll-In T-Nut with Flex Handle	—	—	.038 lb
3319	3340	1			.500"	3278	1	Slide-In Economy T-Nut - Offset Thread	—	—	.037 lb
3355	3330	2			.687"	3279	1	Double Slide-In Economy T-Nut	—	—	.098 lb
3463	3330	1			.687"	3214	1	Hex Nut	3260	1	.033 lb
3323	3330	1			.687"	3282	1	Roll-In T-Nut with Flex Handle	—	—	.041 lb
3320	3330	1			.687"	3278	1	Slide-In Economy T-Nut - Offset Thread	—	—	.039 lb
3357	3330	3			.687"	3285	1	Triple Slide-In Economy T-Nut	—	—	.134 lb

CONTINUE 

5/16-18 Flanged Hex Head Bolt

Assy. No.	Bolt	Qty.	Bolt Type	Thread Size	Bolt Length	Nut	Qty.	Nut Type	Washer	Qty.	Weight
3970	3752	1	Flanged Hex Head Bolt	5/16-18	1.750"	3759	1	Flanged Hex Nut	—	—	.058 lb
3960	3753	1			2.000"	3759	1		—	—	.063 lb

5/16-18 Slide-In Economy T-Slot Stud

Assy. No.	Bolt	Qty.	Bolt Type	Thread Size	Bolt Length	Nut	Qty.	Nut Type	Washer	Qty.	Weight
3745	3716	1	Slide-In Economy T-Slot Stud	5/16-18	.750"	3714	1	Hex Nut	3760	1	.042 lb
3737	3720	1		5/16-18	1.000"	3714	1		3760	1	.045 lb

5/16-18 Slide-In Flanged Economy T-Slot Stud

Assy. No.	Bolt	Qty.	Bolt Type	Thread Size	Bolt Length	Nut	Qty.	Nut Type	Washer	Qty.	Weight
3325	3116	1	Slide-In Flanged Economy T-Slot Stud	5/16-18	.750"	3214	1	Hex Nut	3260	1	.039 lb
3150	3120	1		5/16-18	1.000"	3214	1		3260	1	.045 lb
3474	3120	1		5/16-18	1.000"	3214	1		3260	1	.045 lb
3151	3126	1		5/16-18	1.250"	3214	1		3260	1	.048 lb
3152	3134	1		5/16-18	1.500"	3214	1		3260	1	.051 lb
3153	3288	1		5/16-18	1.750"	3214	1		3260	1	.056 lb
3154	3290	1		5/16-18	2.000"	3214	1		3260	1	.060 lb

5/16-18 Socket Head Cap Screw (SHCS)

Assy. No.	Bolt	Qty.	Bolt Type	Thread Size	Bolt Length	Nut	Qty.	Nut Type	Washer	Qty.	Weight
3452	3106	1	SHCS	5/16-18	.500"	3282	1	Roll-In T-Nut with Flex Handle	—	—	.040 lb
75-3839	3106	1			.500"	3282	1	Roll-In T-Nut with Flex Handle	—	—	.040 lb
3450	3106	1			.500"	3278	1	Slide-In Economy T-Nut - Offset Thread	—	—	.034 lb
3634*	3610	1			.500"	3678	1	Slide-In Economy T-Nut - Offset Thread	—	—	.035 lb
75-3838	3106	1			.500"	3278	1	Slide-In Economy T-Nut - Offset Thread	—	—	.034 lb
3456	3110	1			.625"	3282	1	Roll-In T-Nut with Flex Handle	—	—	.053 lb
3464	3110	1			.625"	3282	1	Roll-In T-Nut with Flex Handle	3260	1	.057 lb
75-3841	3110	1			.625"	3282	1	Roll-In T-Nut with Flex Handle	—	—	.053 lb
75-3847	3110	1			.625"	3282	1	Roll-In T-Nut with Flex Handle	3260	1	.057 lb
3454	3110	1			.625"	3278	1	Slide-In Economy T-Nut - Offset Thread	—	—	.040 lb
3462	3110	1			.625"	3278	1	Slide-In Economy T-Nut - Offset Thread	3260	1	.045 lb
3636*	3612	1			.625"	3678	1	Slide-In Economy T-Nut - Offset Thread	—	—	.036 lb
3699*	3612	1			.625"	3678	1	Slide-In Economy T-Nut - Offset Thread	3659	1	.040 lb
75-3840	3110	1			.625"	3278	1	Slide-In Economy T-Nut - Offset Thread	—	—	.040 lb
75-3846	3110	1			.625"	3278	1	Slide-In Economy T-Nut - Offset Thread	3260	1	.045 lb
3468	3112	1			.750"	3282	1	Roll-In T-Nut with Flex Handle	3260	1	.049 lb
75-3843	3112	1			.750"	3282	1	Roll-In T-Nut with Flex Handle	—	—	.044 lb
75-3849	3112	1			.750"	3282	1	Roll-In T-Nut with Flex Handle	3260	1	.053 lb
3455	3112	1			.750"	3278	1	Slide-In Economy T-Nut - Offset Thread	—	—	.041 lb
3466	3112	1			.750"	3278	1	Slide-In Economy T-Nut - Offset Thread	3260	1	.047 lb
3640*	3615	1			.750"	3678	1	Slide-In Economy T-Nut - Offset Thread	3659	1	.051 lb
75-3842	3112	1			.750"	3278	1	Slide-In Economy T-Nut - Offset Thread	—	—	.041 lb
75-3848	3112	1			.750"	3278	1	Slide-In Economy T-Nut - Offset Thread	3260	1	.045 lb
3446	3119	1			.875"	3214	1	Hex Nut	3260	1	.040 lb
3460	3119	1			.875"	3282	1	Roll-In T-Nut with Flex Handle	—	—	.055 lb

*Assembly comprised of stainless steel (SS) hardware

CONTINUE

Bolt Assemblies (Continued)

5/16-18 Socket Head Cap Screw (SHCS)

Assy. No.	Bolt	Qty.	Bolt Type	Thread Size	Bolt Length	Nut	Qty.	Nut Type	Washer	Qty.	Weight
3458	3119	1	SHCS	5/16-18	.875"	3278	1	Slide-In Economy T-Nut - Offset Thread	—	—	.045 lb
3638*	3619	1			.875"	3678	1	Slide-In Economy T-Nut - Offset Thread	—	—	.039 lb
3473	3122	1			1.000"	3214	1	Hex Nut	3260	1	.042 lb
3472	3122	1			1.000"	3282	1	Roll-In T-Nut with Flex Handle	3260	1	.060 lb
75-3845	3122	1			1.000"	3282	1	Roll-In T-Nut with Flex Handle	—	—	.056 lb
75-3851	3122	1			1.000"	3282	1	Roll-In T-Nut with Flex Handle	3260	1	.060 lb
3470	3122	1			1.000"	3278	1	Slide-In Economy T-Nut - Offset Thread	3260	1	.051 lb
3642*	3622	1			1.000"	3678	1	Slide-In Economy T-Nut - Offset Thread	3659	1	.044 lb
75-3844	3122	1			1.000"	3278	1	Slide-In Economy T-Nut - Offset Thread	—	—	.046 lb
75-3850	3122	1			1.000"	3278	1	Slide-In Economy T-Nut - Offset Thread	3260	1	.051 lb
3421	3123	1			1.300"	3278	1	Slide-In Economy T-Nut - Offset Thread	3260	1	.056 lb
3422	3127	1			1.500"	3278	1	Slide-In Economy T-Nut - Offset Thread	3260	1	.041 lb
3613	3127	1			1.500"	3278	1	Slide-In Economy T-Nut - Offset Thread	—	—	.056 lb
3423	3129	1			1.750"	3278	1	Slide-In Economy T-Nut - Offset Thread	3260	1	.065 lb
3972	3955	1			1.750"	3759	1	Flanged Hex Nut	3760	1	.060 lb
3424	3130	1			2.000"	3278	1	Slide-In Economy T-Nut - Offset Thread	3260	1	.070 lb
3962	3956	1			2.000"	3759	1	Flanged Hex Nut	3760	1	.064 lb
3427	3131	1			2.250"	3278	1	Slide-In Economy T-Nut - Offset Thread	—	—	.072 lb
3428	3132	1			2.500"	3278	1	Slide-In Economy T-Nut - Offset Thread	3260	1	.080 lb
3429	3132	1			2.500"	3278	1	Slide-In Economy T-Nut - Offset Thread	—	—	.076 lb
3430	3133	1	3.000"	3278	1	Slide-In Economy T-Nut - Offset Thread	—	—	.086 lb		
3431	3140	1	3.250"	3278	1	Slide-In Economy T-Nut - Offset Thread	—	—	.093 lb		

*Assembly comprised of stainless steel (SS) hardware

3/8-16 Socket Head Cap Screw (SHCS)

Assy. No.	Bolt	Qty.	Bolt Type	Thread Size	Bolt Length	Nut	Qty.	Nut Type	Washer	Qty.	Weight
3289	3124	1	SHCS	3/8-16	1.000"	—	—	—	3261	1	.051 lb

8-32 Button Head Socket Cap Screw (BHSCS)

Assy. No.	Bolt	Qty.	Bolt Type	Thread Size	Bolt Length	Nut	Qty.	Nut Type	Washer	Qty.	Weight
3483	3005	1	BHSCS	8-32	.375"	3275	1	Slide-In Economy T-Nut - Centered Thread	—	—	.016 lb
3489	3024	1		8-32	.500"	3007	1	8-32 Hex Nut	3006	1	.001 lb

10-32 Button Head Socket Cap Screw (BHSCS)

Assy. No.	Bolt	Qty.	Bolt Type	Thread Size	Bolt Length	Nut	Qty.	Nut Type	Washer	Qty.	Weight
3426	3042	1	BHSCS	10-32	.375"	3205	1	Standard Slide-In T-Nut	—	—	.011 lb
3487	3050	1			.500"	3201	1	Standard Slide-In T-Nut	—	—	.030 lb
3488	3051	1			.625"	3053	1	Hex Nut	3055	1	.008 lb

10-32 Socket Head Cap Screw (SHCS)

Assy. No.	Bolt	Qty.	Bolt Type	Thread Size	Bolt Length	Nut	Qty.	Nut Type	Washer	Qty.	Weight
3457	3044	1	SHCS	10-32	.375"	3276	1	Slide-In Economy T-Nut - Centered Thread	—	—	.013 lb
3459	3052	1			.625"	3053	1	Hex Nut	3055	1	.008 lb

CONTINUE 

M6 x 1.0 Button Head Socket Cap Screw (BHSCS)

Assy. No.	Bolt	Qty.	Bolt Type	Thread Size	Bolt Length	Nut	Qty.	Nut Type	Washer	Qty.	Weight
75-3509	13-6310	2	BHSCS	M6 X 1.0	10.00mm	25-1962	1	Double Slide-In Economy T-Nut	—	—	.033 lb
75-3435	13-6310	1			10.00mm	3876	1	Roll-In T-Nut with Flex Handle	—	—	.014 lb
75-3640	11-6310	1			10.00mm	25-1966	1	Roll-In T-Nut with Flex Handle	—	—	.018 lb
75-3641	11-6310	1			10.00mm	25-1966	1	Roll-In T-Nut with Flex Handle	—	—	.012 lb
75-3642	11-6310	1			10.00mm	25-1966	1	Roll-In T-Nut with Flex Handle	—	—	.014 lb
75-3404	13-6310	1			10.00mm	3859	1	Slide-In Economy T-Nut - Centered Thread	—	—	.030 lb
75-3515	11-6310	1			10.00mm	3859	1	Slide-In Economy T-Nut - Centered Thread	—	—	.032 lb
75-3599	11-6310	1			10.00mm	3931	1	Standard Drop-In T-Nut	—	—	.012 lb
75-3510	13-6312	2			12.00mm	25-1962	1	Double Slide-In Economy T-Nut	—	—	.034 lb
75-3511	13-6312	2			12.00mm	25-1962	1	Double Slide-In Economy T-Nut	13-6041	2	.038 lb
75-3466	13-6312	1			12.00mm	13-6065	1	Hex Nut	13-6041	1	.014 lb
75-3436	13-6312	1			12.00mm	3876	1	Roll-In T-Nut with Flex Handle	—	—	.015 lb
3824	3802	1			12.00mm	3876	1	Roll-In T-Nut with Flex Handle	3861	1	.017 lb
3867	3802	1			12.00mm	3876	1	Roll-In T-Nut with Flex Handle	—	—	.015 lb
75-3439	13-6312	1			12.00mm	3876	1	Roll-In T-Nut with Flex Handle	13-6041	1	.016 lb
75-3405	13-6312	1			12.00mm	3859	1	Slide-In Economy T-Nut - Centered Thread	—	—	.016 lb
75-3408	13-6312	1			12.00mm	3859	1	Slide-In Economy T-Nut - Centered Thread	13-6041	1	.019 lb
75-3516	11-6312	1			12.00mm	3859	1	Slide-In Economy T-Nut - Centered Thread	—	—	.017 lb
75-3518	11-6312	1			12.00mm	3859	1	Slide-In Economy T-Nut - Centered Thread	11-6041	1	.014 lb
75-3600	11-6312	1			12.00mm	3931	1	Standard Drop-In T-Nut	—	—	.014 lb
75-3603	11-6314	1			14.00mm	11-6065	1	Hex Nut	—	—	.013 lb
75-3643	11-6314	1			14.00mm	25-1966	1	Roll-In T-Nut with Flex Handle	—	—	.015 lb
75-3601	11-6314	1			14.00mm	13119	1	Standard Drop-In T-Nut	—	—	.015 lb
75-3602	11-6314	1			14.00mm	13129	1	Standard Drop-In T-Nut	—	—	.023 lb
75-3622	11-6314	1			14.00mm	13119	1	Standard Drop-In T-Nut	—	—	.015 lb
75-3467	13-6316	1			16.00mm	13-6065	1	Hex Nut	13-6041	1	.014 lb
75-3437	13-6316	1			16.00mm	3876	1	Roll-In T-Nut with Flex Handle	—	—	.015 lb
3827	3804	1			16.00mm	3876	1	Roll-In T-Nut with Flex Handle	3861	1	.018 lb
75-3440	13-6316	1			16.00mm	3876	1	Roll-In T-Nut with Flex Handle	13-6041	1	.016 lb
75-3406	13-6316	1			16.00mm	3859	1	Slide-In Economy T-Nut - Centered Thread	—	—	.019 lb
3826	3804	1			16.00mm	3836	1	Slide-In Economy T-Nut - Centered Thread	3861	1	.028 lb
75-3409	13-6316	1			16.00mm	3859	1	Slide-In Economy T-Nut - Centered Thread	13-6041	1	.017 lb
75-3480	13-6316	1			16.00mm	40-1961	1	Slide-In Economy T-Nut - Centered Thread	13-6041	1	.028 lb
75-3517	11-6316	1			16.00mm	3859	1	Slide-In Economy T-Nut - Centered Thread	—	—	.020 lb
75-3519	11-6316	1			16.00mm	3859	1	Slide-In Economy T-Nut - Centered Thread	11-6041	1	.020 lb
75-3477	13-6316	1			16.00mm	—	—	—	13-6041	1	.010 lb
75-3605	11-6318	1			18.00mm	11-6065	1	Hex Nut	11-6041	1	.054 lb
75-3482	11-6318	1			18.00mm	13129	1	Standard Drop-In T-Nut	—	—	.024 lb
75-3468	13-6320	1			20.00mm	13-6065	1	Hex Nut	13-6041	1	.017 lb
3850	3808	1			20.00mm	3876	1	Roll-In T-Nut with Flex Handle	3861	1	.020 lb
75-3438	13-6320	1			20.00mm	3876	1	Roll-In T-Nut with Flex Handle	—	—	.018 lb
75-3441	13-6320	1			20.00mm	3876	1	Roll-In T-Nut with Flex Handle	13-6041	1	.020 lb
75-3407	13-6320	1	20.00mm	3859	1	Slide-In Economy T-Nut - Centered Thread	—	—	.019 lb		
75-3410	13-6320	1	20.00mm	3859	1	Slide-In Economy T-Nut - Centered Thread	13-6041	1	.021 lb		
3829	3809	1	25.00mm	3876	1	Roll-In T-Nut with Flex Handle	3861	1	.022 lb		

CONTINUE

Bolt Assemblies (Continued)

M6 x 1.0 Flat Head Socket Cap Screw (FHSCS)

Assy. No.	Bolt	Qty.	Bolt Type	Thread Size	Bolt Length	Nut	Qty.	Nut Type	Washer	Qty.	Weight
75-3541	13-6710	2	FHSCS	M6 X 1.0	10.00mm	25-1961	2	Slide-In Economy T-Nut - Centered Thread	—	—	.016 lb
75-3505	13-6712	1			12.00mm	3876	1	Roll-In T-Nut with Flex Handle	—	—	.015 lb
75-3645	13-6712	1			12.00mm	25-1966	1	Roll-In T-Nut with Flex Handle	—	—	.014 lb
75-3507	13-6712	1			12.00mm	3859	1	Slide-In Economy T-Nut - Centered Thread	—	—	.016 lb
75-3639	17-6712*	1			12.00mm	3873	1	Standard Slide-In T-Nut	—	—	.014 lb
75-3616	11-6714	1			14.00mm	3873	1	Standard Slide-In T-Nut	—	—	.011 lb
75-3584	11-6714	1			14.00mm	3873	1	Standard Slide-In T-Nut	—	—	.011 lb
75-3585	11-6714	1			14.00mm	3931	1	Standard Drop-In T-Nut	—	—	.015 lb
75-3647	11-6716	1			16.00mm	25-1966	1	Roll-In T-Nut with Flex Handle	—	—	.011 lb
75-3655	11-6716	1			16.00mm	40-1966	1	Roll-In T-Nut with Flex Handle	—	—	.026 lb
75-3591	11-6716	1			16.00mm	13119	1	Standard Drop-In T-Nut	—	—	.016 lb
75-3587	11-6718	1			18.00mm	13129	1	Standard Drop-In T-Nut	—	—	.011 lb
75-3628	11-6718	1			18.00mm	13119	1	Standard Drop-In T-Nut	—	—	.012 lb
75-3589	11-6720	1			20.00mm	11-6065	1	Hex Nut	11-6041	1	.011 lb
75-3644	11-6720	1			20.00mm	25-1966	1	Roll-In T-Nut with Flex Handle	—	—	.017 lb
75-3654	11-6720	1			20.00mm	40-1966	1	Roll-In T-Nut with Flex Handle	—	—	.026 lb
75-3588	11-6720	1			20.00mm	13129	1	Standard Drop-In T-Nut	—	—	.011 lb

M6 x 1.0 Socket Head Cap Screw (SHCS)

Assy. No.	Bolt	Qty.	Bolt Type	Thread Size	Bolt Length	Nut	Qty.	Nut Type	Washer	Qty.	Weight
75-3442	13-6510	1	SHCS	M6 X 1.0	10.00mm	3876	1	Roll-In T-Nut with Flex Handle	—	—	.014 lb
75-3520	11-6510	1			10.00mm	3859	1	Slide-In Economy T-Nut - Centered Thread	—	—	.019 lb
75-3411	13-6510	1			10.00mm	3859	1	Slide-In Economy T-Nut - Centered Thread	—	—	.019 lb
75-3590	11-6510	1			10.00mm	3931	1	Standard Drop-In T-Nut	—	—	.017 lb
75-3469	13-6512	1			12.00mm	13-6065	1	Hex Nut	13-6041	1	.016 lb
3833	3801	1			12.00mm	3876	1	Roll-In T-Nut with Flex Handle	—	—	.022 lb
3849	3801	1			12.00mm	3876	1	Roll-In T-Nut with Flex Handle	3861	1	.020 lb
75-3443	13-6512	1			12.00mm	3876	1	Roll-In T-Nut with Flex Handle	—	—	.014 lb
75-3450	13-6512	1			12.00mm	3876	1	Roll-In T-Nut with Flex Handle	13-6041	1	.020 lb
75-3412	13-6512	1			12.00mm	3859	1	Slide-In Economy T-Nut - Centered Thread	—	—	.019 lb
75-3521	11-6512	1			12.00mm	3859	1	Slide-In Economy T-Nut - Centered Thread	—	—	.020 lb
3831	3801	1			12.00mm	3836	1	Slide-In Economy T-Nut - Centered Thread	—	—	.022 lb
75-3419	13-6512	1			12.00mm	3859	1	Slide-In Economy T-Nut - Centered Thread	13-6041	1	.022 lb
75-3598	11-6512	1			12.00mm	3931	1	Standard Drop-In T-Nut	—	—	.020 lb
75-3592	11-6514	1			14.00mm	3873	1	Standard Slide-In T-Nut	—	—	.012 lb
75-3593	11-6514	1			14.00mm	3931	1	Standard Drop-In T-Nut	—	—	.018 lb
75-3594	11-6514	1			14.00mm	13129	1	Standard Drop-In T-Nut	—	—	.012 lb
75-3470	13-6516	1			16.00mm	13-6065	1	Hex Nut	13-6041	1	.018 lb
3856	3803	1			16.00mm	3876	1	Roll-In T-Nut with Flex Handle	3861	1	.022 lb
75-3444	13-6516	1			16.00mm	3876	1	Roll-In T-Nut with Flex Handle	—	—	.015 lb
75-3451	13-6516	1			16.00mm	3876	1	Roll-In T-Nut with Flex Handle	13-6041	1	.022 lb
75-3413	13-6516	1			16.00mm	3859	1	Slide-In Economy T-Nut - Centered Thread	—	—	.017 lb
75-3522	11-6516	1			16.00mm	3859	1	Slide-In Economy T-Nut - Centered Thread	—	—	.021 lb
3835	3803	1			16.00mm	3836	1	Slide-In Economy T-Nut - Centered Thread	—	—	.029 lb
75-3420	13-6516	1			16.00mm	3859	1	Slide-In Economy T-Nut - Centered Thread	13-6041	1	.033 lb
75-3595	11-6516	1			16.00mm	3931	1	Standard Drop-In T-Nut	—	—	.019 lb
75-3596	11-6518	1			18.00mm	3931	1	Standard Drop-In T-Nut	—	—	.019 lb

CONTINUE

M6 x 1.0 Socket Head Cap Screw (SHCS)

Assy. No.	Bolt	Qty.	Bolt Type	Thread Size	Bolt Length	Nut	Qty.	Nut Type	Washer	Qty.	Weight
3847	3806	1	SHCS	M6 X 1.0	20.00mm	3876	1	Roll-In T-Nut with Flex Handle	—	—	.021 lb
3855	3806	1			20.00mm	3876	1	Roll-In T-Nut with Flex Handle	3861	1	.023 lb
75-3445	13-6520	1			20.00mm	3876	1	Roll-In T-Nut with Flex Handle	—	—	.021 lb
3035	13-6520	1			20.00mm	3859	1	Slide-In Economy T-Nut - Centered Thread	—	—	.022 lb
75-3414	13-6520	1			20.00mm	3859	1	Slide-In Economy T-Nut - Centered Thread	—	—	.022 lb
75-3523	11-6520	1			20.00mm	3859	1	Slide-In Economy T-Nut - Centered Thread	—	—	.029 lb
75-3597	11-6520	1			20.00mm	13129	1	Standard Drop-In T-Nut	—	—	.010 lb
3845	3807	1			25.00mm	3876	1	Roll-In T-Nut with Flex Handle	—	—	.023 lb
3862	3807	1			25.00mm	3876	1	Roll-In T-Nut with Flex Handle	3861	1	.025 lb
75-3446	13-6525	1			25.00mm	3876	1	Roll-In T-Nut with Flex Handle	—	—	.023 lb
75-3415	13-6525	1			25.00mm	3859	1	Slide-In Economy T-Nut - Centered Thread	—	—	.024 lb
3841	3807	1			25.00mm	3836	1	Slide-In Economy T-Nut - Centered Thread	—	—	.031 lb
75-3524	11-6525	1			25.00mm	3859	1	Slide-In Economy T-Nut - Centered Thread	—	—	.031 lb
75-3447	13-6530	1			30.00mm	3876	1	Roll-In T-Nut with Flex Handle	—	—	.025 lb
75-3416	13-6530	1			30.00mm	3859	1	Slide-In Economy T-Nut - Centered Thread	—	—	.030 lb
75-3448	13-6535	1			35.00mm	3876	1	Roll-In T-Nut with Flex Handle	—	—	.029 lb
75-3417	13-6535	1			35.00mm	3859	1	Slide-In Economy T-Nut - Centered Thread	—	—	.029 lb
75-3449	13-6540	1			40.00mm	3876	1	Roll-In T-Nut with Flex Handle	—	—	.030 lb
75-3418	13-6540	1			40.00mm	3859	1	Slide-In Economy T-Nut - Centered Thread	—	—	.036 lb

M8 x 1.25 Button Head Socket Cap Screw (BHSCS)

Assy. No.	Bolt	Qty.	Bolt Type	Thread Size	Bolt Length	Nut	Qty.	Nut Type	Washer	Qty.	Weight
75-3512	13-8312	2	BHSCS	M8 X 1.25	12.00mm	40-1982	1	Double Slide-In Economy T-Nut	—	—	.094 lb
75-3452	13-8312	1			12.00mm	3842	1	Roll-In T-Nut with Flex Handle	—	—	.036 lb
75-3649	11-8312	1			12.00mm	40-1986	1	Roll-In T-Nut with Flex Handle	—	—	.036 lb
75-3615	11-8312	1			12.00mm	13094	1	Self-Aligning Roll-In T-Nut	—	—	.022 lb
75-3421	13-8312	1			12.00mm	3838	1	Slide-In Economy T-Nut - Offset Thread	—	—	.036 lb
75-3525	11-8312	1			12.00mm	3838	1	Slide-In Economy T-Nut - Offset Thread	—	—	.036 lb
75-3513	13-8316	2			16.00mm	40-1982	1	Double Slide-In Economy T-Nut	—	—	.099 lb
75-3514	13-8316	2			16.00mm	40-1982	1	Double Slide-In Economy T-Nut	13-6042	2	.105 lb
75-3471	13-8316	1			16.00mm	13-8065	1	Hex Nut	13-6042	1	.030 lb
3832	3813	1			16.00mm	3842	1	Roll-In T-Nut with Flex Handle	3860	1	.042 lb
75-3453	13-8316	1			16.00mm	3842	1	Roll-In T-Nut with Flex Handle	—	—	.039 lb
75-3456	13-8316	1			16.00mm	3842	1	Roll-In T-Nut with Flex Handle	13-6042	1	.042 lb
75-3650	11-8316	1			16.00mm	40-1986	1	Roll-In T-Nut with Flex Handle	—	—	.039 lb
75-3422	13-8316	1			16.00mm	3838	1	Slide-In Economy T-Nut - Offset Thread	—	—	.038 lb
75-3425	13-8316	1			16.00mm	3838	1	Slide-In Economy T-Nut - Offset Thread	13-6042	1	.041 lb
75-3526	11-8316	1			16.00mm	3838	1	Slide-In Economy T-Nut - Offset Thread	—	—	.038 lb
75-3528	11-8316	1			16.00mm	3838	1	Slide-In Economy T-Nut - Offset Thread	11-6042	1	.042 lb
3830	3813	1			16.00mm	3838	1	Slide-In Economy T-Nut - Offset Thread	3860	1	.041 lb
75-3651	11-8318	1			18.00mm	40-1986	1	Roll-In T-Nut with Flex Handle	—	—	.040 lb
75-3619	11-8318	1			18.00mm	13132	1	Standard Drop-In T-Nut	—	—	.024 lb
75-3472	13-8320	1			20.00mm	13-8065	1	Hex Nut	13-6042	1	.032 lb
3863	3815	2			20.00mm	3879	1	Double Slide-In Economy T-Nut	3860	2	.093 lb
3872	3815	1			20.00mm	3842	1	Roll-In T-Nut with Flex Handle	3860	1	.044 lb
75-3454	13-8320	1			20.00mm	3842	1	Roll-In T-Nut with Flex Handle	—	—	.041 lb

CONTINUE

Bolt Assemblies (Continued)

M8 x 1.25 Button Head Socket Cap Screw (BHSCS)

Assy. No.	Bolt	Qty.	Bolt Type	Thread Size	Bolt Length	Nut	Qty.	Nut Type	Washer	Qty.	Weight
75-3457	13-8320	1	BHSCS	M8 X 1.25	20.00mm	3842	1	Roll-In T-Nut with Flex Handle	13-6042	1	.045 lb
75-3648	11-8320	1			20.00mm	40-1986	1	Roll-In T-Nut with Flex Handle	—	—	.032 lb
3870	3815	1			20.00mm	3838	1	Slide-In Economy T-Nut - Offset Thread	3860	1	.044 lb
75-3423	13-8320	1			20.00mm	3838	1	Slide-In Economy T-Nut - Offset Thread	—	—	.041 lb
75-3426	13-8320	1			20.00mm	3838	1	Slide-In Economy T-Nut - Offset Thread	13-6042	1	.044 lb
75-3527	11-8320	1			20.00mm	3838	1	Slide-In Economy T-Nut - Offset Thread	—	—	.031 lb
75-3529	11-8320	1			20.00mm	3838	1	Slide-In Economy T-Nut - Offset Thread	11-6042	1	.035 lb
75-3478	13-8320	1			20.00mm	—	—	—	13-6042	1	.023 lb
3886	3819	1			25.00mm	3842	1	Roll-In T-Nut with Flex Handle	3860	1	.049 lb
75-3455	13-8325	1			25.00mm	3842	1	Roll-In T-Nut with Flex Handle	—	—	.044 lb
75-3458	13-8325	1			25.00mm	3842	1	Roll-In T-Nut with Flex Handle	13-6042	1	.048 lb
3877	3819	1			25.00mm	3838	1	Slide-In Economy T-Nut - Offset Thread	3860	1	.043 lb
75-3427	13-8325	1			25.00mm	3838	1	Slide-In Economy T-Nut - Offset Thread	13-6042	1	.047 lb
75-3473	13-8325	1			25.00mm	13-8065	1	Hex Nut	13-6042	1	.035 lb
3974	13-3945	1			45.00mm	13-3759	1	Flanged Hex Nut	3860	1	.058 lb
3964	13-3946	1			50.00mm	13-3759	1	Flanged Hex Nut	3860	1	.061 lb

M8 x 1.25 Flanged Hex Head Bolt

Assy. No.	Bolt	Qty.	Bolt Type	Thread Size	Bolt Length	Nut	Qty.	Nut Type	Washer	Qty.	Weight
3963	13-3753	1	Flanged Hex Head Bolt	M8 x 1.25	50.00mm	13-3759	1	Flanged Hex Nut	—	—	.077 lb

M8 x 1.25 Flat Head Socket Cap Screw (FHSCS)

Assy. No.	Bolt	Qty.	Bolt Type	Thread Size	Bolt Length	Nut	Qty.	Nut Type	Washer	Qty.	Weight
75-3506	13-8716	1	FHSCS	M8 X 1.25	16.00mm	3842	1	Roll-In T-Nut with Flex Handle	—	—	.029 lb
75-3653	11-8716	1			16.00mm	40-1986	1	Roll-In T-Nut with Flex Handle	—	—	.036 lb
75-3629	11-8716	1			16.00mm	13025	1	Self-Aligning Slide-In T-Nut	—	—	.031 lb
75-3508	13-8716	1			16.00mm	3838	1	Slide-In Economy T-Nut - Offset Thread	—	—	.028 lb
75-3618	11-8716	1			16.00mm	40-1981	1	Slide-In Economy T-Nut - Offset Thread	—	—	.036 lb
75-3617	11-8720	1			20.00mm	11-8065	1	Hex Nut	—	—	.028 lb
75-3652	11-8720	1			20.00mm	40-1986	1	Roll-In T-Nut with Flex Handle	—	—	.024 lb

M8 x 1.25 Slide-In Flanged Economy T-Slot Stud

Assy. No.	Bolt	Qty.	Bolt Type	Thread Size	Bolt Length	Nut	Qty.	Nut Type	Washer	Qty.	Weight
3825	3851	1	Slide-In Flanged Economy T-Slot Stud	M8 X 1.25	20.00mm	3821	1	Hex Nut	3860	1	.042 lb
3880	3851	1			20.00mm	3821	1	Hex Nut	3860	1	.040 lb
3889	3851	1			20.00mm	3821	1	Hex Nut	3860	1	.040 lb
75-3500	3851	1			20.00mm	3821	1	Hex Nut	3860	1	.040 lb
3881	3852	1			25.00mm	3821	1	Hex Nut	3860	1	.043 lb
75-3501	3852	1			25.00mm	3821	1	Hex Nut	3860	1	.043 lb
3882	3853	1			30.00mm	3821	1	Hex Nut	3860	1	.046 lb
3890	3853	1			30.00mm	3821	1	Hex Nut	3860	1	.046 lb
75-3502	3853	1			30.00mm	3821	1	Hex Nut	3860	1	.046 lb
3883	3854	1			35.00mm	3821	1	Hex Nut	3860	1	.051 lb
75-3503	3854	1			35.00mm	3821	1	Hex Nut	3860	1	.051 lb
3884	3857	1			45.00mm	3821	1	Hex Nut	3860	1	.058 lb
75-3504	3857	1			45.00mm	3821	1	Hex Nut	3860	1	.058 lb

CONTINUE

M8 x 1.25 Socket Head Cap Screw (SHCS)

Assy. No.	Bolt	Qty.	Bolt Type	Thread Size	Bolt Length	Nut	Qty.	Nut Type	Washer	Qty.	Weight
3840	3810	1	SHCS	M8 X 1.25	12.00mm	3842	1	Roll-In T-Nut with Flex Handle	—	—	.043 lb
75-3459	13-8512	1			12.00mm	3842	1	Roll-In T-Nut with Flex Handle	—	—	.044 lb
75-3624	11-8512	1			12.00mm	13025	1	Self-Aligning Slide-In T-Nut	—	—	.037 lb
3834	3810	1			12.00mm	3838	1	Slide-In Economy T-Nut - Offset Thread	—	—	.041 lb
75-3428	13-8512	1			12.00mm	3838	1	Slide-In Economy T-Nut - Offset Thread	—	—	.041 lb
75-3530	11-8512	1			12.00mm	3838	1	Slide-In Economy T-Nut - Offset Thread	—	—	.023 lb
75-3620	11-8512	1			12.00mm	30-3796	1	Slide-In Economy T-Nut - Centered Thread	—	—	.021 lb
3865	3812	1			16.00mm	3842	1	Roll-In T-Nut with Flex Handle	—	—	.036 lb
3878	3812	1			16.00mm	3842	1	Roll-In T-Nut with Flex Handle	3860	1	.039 lb
75-3460	13-8516	1			16.00mm	3842	1	Roll-In T-Nut with Flex Handle	—	—	.046 lb
75-3463	13-8516	1			16.00mm	3842	1	Roll-In T-Nut with Flex Handle	13-6042	1	.049 lb
75-3625	11-8516	1			16.00mm	13025	1	Self-Aligning Slide-In T-Nut	—	—	.040 lb
75-3621	11-8516	1			16.00mm	3838	1	Slide-In Economy T-Nut - Offset Thread	—	—	.044 lb
3864	3812	1			16.00mm	3838	1	Slide-In Economy T-Nut - Offset Thread	—	—	.058 lb
3874	3812	1			16.00mm	3838	1	Slide-In Economy T-Nut - Offset Thread	3860	1	.038 lb
75-3429	13-8516	1			16.00mm	3838	1	Slide-In Economy T-Nut - Offset Thread	—	—	.032 lb
75-3432	13-8516	1			16.00mm	3838	1	Slide-In Economy T-Nut - Offset Thread	13-6042	1	.032 lb
75-3531	11-8516	1			16.00mm	3838	1	Slide-In Economy T-Nut - Offset Thread	—	—	.044 lb
75-3534	11-8516	1			16.00mm	3838	1	Slide-In Economy T-Nut - Offset Thread	11-6042	1	.049 lb
75-3623	11-8516	1			16.00mm	13132	1	Standard Drop-In T-Nut	—	—	.037 lb
75-3627	11-8518	1			18.00mm	13025	1	Self-Aligning Slide-In T-Nut	—	—	.041 lb
75-3634	11-8518	1			18.00mm	3838	1	Slide-In Economy T-Nut - Offset Thread	—	—	.045 lb
75-3626	11-8518	1			18.00mm	13132	1	Standard Drop-In T-Nut	—	—	.038 lb
75-3475	13-8520	1			20.00mm	13-8065	1	Hex Nut	13-6042	1	.041 lb
3817	3814	1			20.00mm	3842	1	Roll-In T-Nut with Flex Handle	3860	1	.053 lb
3869	3814	1			20.00mm	3842	1	Roll-In T-Nut with Flex Handle	—	—	.049 lb
75-3461	13-8520	1			20.00mm	3842	1	Roll-In T-Nut with Flex Handle	—	—	.047 lb
75-3464	13-8520	1			20.00mm	3842	1	Roll-In T-Nut with Flex Handle	13-6042	1	.050 lb
3816	3814	1			20.00mm	3838	1	Slide-In Economy T-Nut - Offset Thread	3860	1	.051 lb
3899	3814	1			20.00mm	3838	1	Slide-In Economy T-Nut - Offset Thread	—	—	.048 lb
75-3433	13-8520	1			20.00mm	3838	1	Slide-In Economy T-Nut - Offset Thread	13-6042	1	.049 lb
75-3535	11-8520	1			20.00mm	3838	1	Slide-In Economy T-Nut - Offset Thread	11-6042	1	.051 lb
75-3430	13-8520	1			20.00mm	3838	1	Slide-In Economy T-Nut - Offset Thread	—	—	.046 lb
75-3630	11-8520	1			20.00mm	13132	1	Standard Drop-In T-Nut	—	—	.039 lb
75-3476	13-8525	1			25.00mm	13-8065	1	Hex Nut	13-6042	1	.044 lb
3888	3818	1			25.00mm	3842	1	Roll-In T-Nut with Flex Handle	3860	1	.056 lb
75-3462	13-8525	1			25.00mm	3842	1	Roll-In T-Nut with Flex Handle	—	—	.053 lb
75-3465	13-8525	1			25.00mm	3842	1	Roll-In T-Nut with Flex Handle	13-6042	1	.057 lb
3887	3818	1			25.00mm	3838	1	Slide-In Economy T-Nut - Offset Thread	3860	1	.054 lb
75-3431	13-8525	1			25.00mm	3838	1	Slide-In Economy T-Nut - Offset Thread	—	—	.050 lb
75-3434	13-8525	1			25.00mm	3838	1	Slide-In Economy T-Nut - Offset Thread	13-6042	1	.055 lb
75-3533	11-8525	1			25.00mm	3838	1	Slide-In Economy T-Nut - Offset Thread	—	—	.051 lb
75-3536	11-8525	1			25.00mm	3838	1	Slide-In Economy T-Nut - Offset Thread	11-6042	1	.054 lb
75-3479	13-8540	1			40.00mm	3838	1	Slide-In Economy T-Nut - Offset Thread	—	—	.040 lb
3975	13-3955	1			45.00mm	13-3759	1	Flanged Hex Nut	3860	1	.065 lb
3965	13-3956	1			50.00mm	13-3759	1	Flanged Hex Nut	3860	1	.070 lb

CONTINUE

Bolt Assemblies (Continued)

M4 x 0.7 Button Head Socket Cap Screw (BHSCS)

Assy. No.	Bolt	Qty.	Bolt Type	Thread Size	Bolt Length	Nut	Qty.	Nut Type	Washer	Qty.	Weight
75-3537	11-4310	1	BHSCS	M4 x 0.7	10.00mm	25-1941	1	Slide-In Economy T-Nut - Offset Thread	—	—	.008 lb
75-3538	11-4312	1			12.00mm	11-4065	1	Hex Nut	11-6039	1	.005 lb

M4 x 0.7 Flat Head Socket Cap Screw (FHSCS)

Assy. No.	Bolt	Qty.	Bolt Type	Thread Size	Bolt Length	Nut	Qty.	Nut Type	Washer	Qty.	Weight
75-3552	11-4710	1	FHSCS	M4 x 0.7	10.00mm	14159	1	Slide-In Economy T-Nut Block	—	—	.005 lb
75-3562	11-4712	1			12.00mm	11-4065	1	Hex Nut	11-6039	1	.004 lb

M4 x 0.7 Socket Head Cap Screw (SHCS)

Assy. No.	Bolt	Qty.	Bolt Type	Thread Size	Bolt Length	Nut	Qty.	Nut Type	Washer	Qty.	Weight
75-3556	11-4510	1	SHCS	M4 x 0.7	10.00mm	14164	1	Standard Drop-In T-Nut	—	—	.0031 kg
75-3563	11-4512	1			12.00mm	13123	1	Standard Drop-In T-Nut	—	—	.0099 kg
75-3558	11-4516	1			16.00mm	11-4065	1	Hex Nut	11-6039	1	.021 lb

M5 x 0.8 Button Head Socket Cap Screw (BHSCS)

Assy. No.	Bolt	Qty.	Bolt Type	Thread Size	Bolt Length	Nut	Qty.	Nut Type	Washer	Qty.	Weight
75-3581	11-5308	1	BHSCS	M5 X 0.8	8.00mm	14122	1	Slide-In Economy T-Nut Block	—	—	.010 lb
75-3539	11-5312	1			12.00mm	3871	1	Standard Slide-In T-Nut	—	—	.013 lb
75-3583	11-5312	1			12.00mm	3930	1	Standard Drop-In T-Nut	—	—	.009 lb
75-3576	11-5314	1			14.00mm	11-5065	1	Hex Nut	11-6040	1	.009 lb
75-3540	11-5316	1			16.00mm	11-5065	1	Hex Nut	11-6040	1	.009 lb

M5 x 0.8 Flat Head Socket Cap Screw (FHSCS)

Assy. No.	Bolt	Qty.	Bolt Type	Thread Size	Bolt Length	Nut	Qty.	Nut Type	Washer	Qty.	Weight
75-3571	11-5708	1	FHSCS	M5 X 0.8	8.00mm	14122	1	Slide-In Economy T-Nut Block	—	—	.010 lb
75-3572	11-5710	1			10.00mm	14122	1	Slide-In Economy T-Nut Block	—	—	.007 lb
75-3573	11-5714	1			14.00mm	11-5065	1	Hex Nut	11-6040	1	.008 lb
75-3574	11-5714	1			14.00mm	3930	1	Standard Drop-In T-Nut	—	—	.012 lb
75-3575	11-5716	1			16.00mm	3930	1	Standard Drop-In T-Nut	—	—	.012 lb

M5 x 0.8 Socket Head Cap Screw (SHCS)

Assy. No.	Bolt	Qty.	Bolt Type	Thread Size	Bolt Length	Nut	Qty.	Nut Type	Washer	Qty.	Weight
75-3401	13-5510	1	SHCS	M5 X 0.8	10.00mm	25-1951	1	Slide-In Economy T-Nut - Offset Thread	—	—	.012 lb
75-3578	11-5512	1			12.00mm	14122	1	Slide-In Economy T-Nut Block	—	—	.009 lb
75-3400	13-5516	1			16.00mm	13-5065	1	Hex Nut	13-6040	1	.011 lb
75-3483	11-5516	1			16.00mm	13116	1	Standard Drop-In T-Nut	11-6040	1	.009 lb
75-3481	11-5520	1			20.00mm	13127	1	Standard Drop-In T-Nut	11-6040	1	.012 lb

Part Description:

The standard tube insert is used to make strong connections between Ready Tube profiles. It connects profiles together when their lengths are divisible by 1.50". The standard tube insert requires no additional machining services when used in Ready Tube profiles with predrilled holes. See below for information on hardware for the standard tube insert. **Additional Information:** For a custom length insert, see the tube insert profile on page 848.

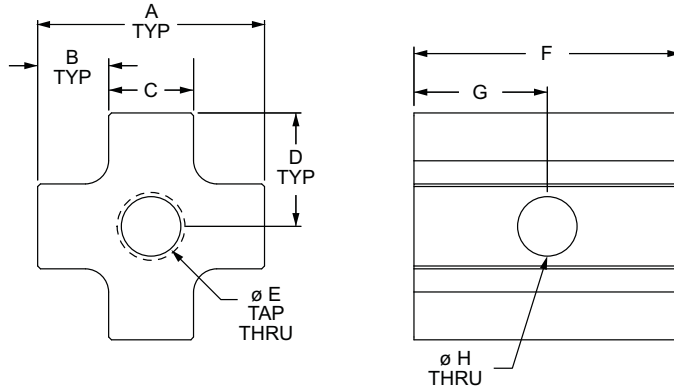

Part No.	Series	Material	Finish	A	B	C	D	E (Thread)	F	G	H	Weight
4600	RT	Aluminum	Mill	1.225"	.382"	.459"	.613"	5/16-18	1.380"	.690"	.332"	.108 lb
4600-Black	RT		Black Anodize	1.225"	.382"	.459"	.613"	5/16-18	1.380"	.690"	.332"	.108 lb
4601	RT		Mill	1.225"	.382"	.459"	.613"	M8 x 1.25	1.440"	.720"	.332"	.112 lb
4601-Black	RT		Black Anodize	1.225"	.382"	.459"	.613"	M8 x 1.25	1.440"	.720"	.332"	.112 lb

Suggested Hardware

Insert	Part No.	Series	Qty.	Description
4600	3970	RT	1	5/16-18 x 1.75" Flanged Hex Head Bolt Assembly
	3753	RT	1	5/16-18 x 2.00" Flanged Hex Head Bolt
4601	13-3945	RT	1	M8 x 1.25" BHSCS
	3963	RT	1	M8 x 1.25" Flanged Hex Nut
				M8 x 50.00mm Flanged Hex Head Bolt

Standard Tube Insert Kit with Hex Nut

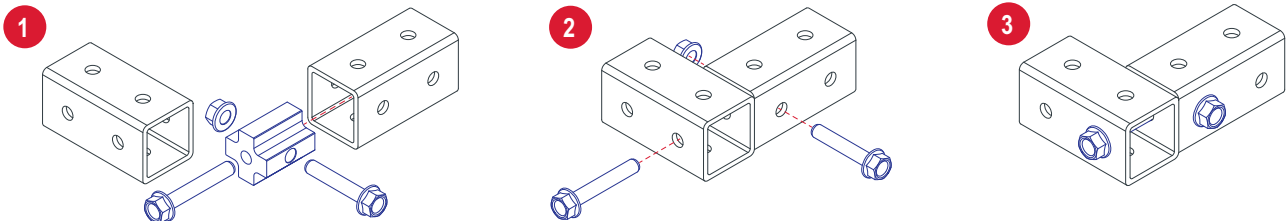

Extended Tube Insert

Part Description:

The extended tube insert connects Ready Tube profiles together when their lengths are not divisible by 1.50". It is also commonly used to add casters and leveling feet and requires no additional machining services when used in Ready Tube profiles with predrilled holes. See below for information on hardware for the standard tube insert. **Additional Information:** For a custom length insert, see the tube insert profile on page 848.

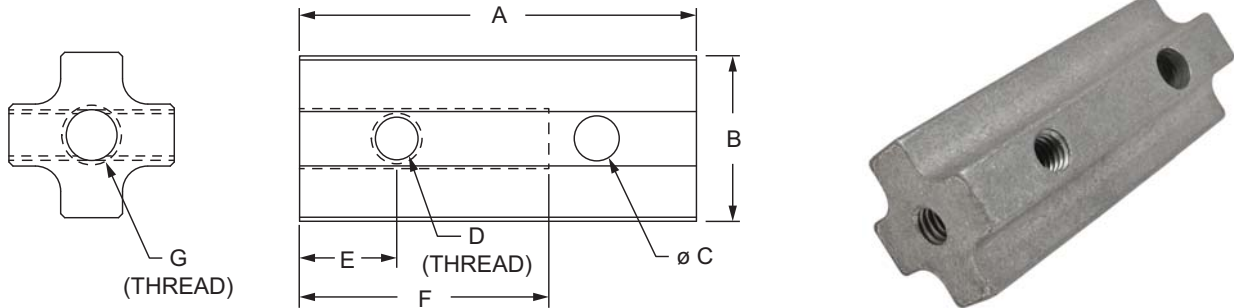

Part No.	Series	Material	Finish	A	B	C	D (Thread)	E	F	G (Thread)	Weight
4605	RT	Aluminum	Mill	2.940"	1.225"	.332"	5/16-18	.720"	2.000"	5/16-18	.233 lb
4605-Black	RT		Black Anodize	2.940"	1.225"	.332"	5/16-18	.720"	2.000"	5/16-18	.233 lb
4606	RT		Mill	2.940"	1.225"	.332"	M8 x 1.25	.720"	2.000"	M8 x 1.25	.231 lb
4606-Black	RT		Black Anodize	2.940"	1.225"	.332"	M8 x 1.25	.720"	2.000"	M8 x 1.25	.231 lb
4607	RT		Mill	2.940"	1.225"	.332"	5/16-18	.720"	2.000"	3/8-16	.227 lb
4607-Black	RT		Black Anodize	2.940"	1.225"	.332"	5/16-18	.720"	2.000"	3/8-16	.227 lb
4608	RT		Mill	2.940"	1.225"	.332"	M8 x 1.25	.720"	2.000"	M10 x 1.5	.224 lb
4608-Black	RT		Black Anodize	2.940"	1.225"	.332"	M8 x 1.25	.720"	2.000"	M10 x 1.5	.224 lb
4609	RT		Mill	2.940"	1.225"	.332"	5/16-18	.720"	2.000"	7/16-14	.221 lb
4609-Black	RT		Black Anodize	2.940"	1.225"	.332"	5/16-18	.720"	2.000"	7/16-14	.221 lb
4610	RT		Mill	2.940"	1.225"	.332"	M8 x 1.25	.720"	2.000"	M12 x 1.75	.213 lb
4610-Black	RT		Black Anodize	2.940"	1.225"	.332"	M8 x 1.25	.720"	2.000"	M12 x 1.75	.213 lb
4611	RT		Mill	2.940"	1.225"	.332"	5/16-18	.720"	2.000"	1/2-13	.210 lb
4611-Black	RT		Black Anodize	2.940"	1.225"	.332"	5/16-18	.720"	2.000"	1/2-13	.210 lb

Suggested Hardware

Insert	Part No.	Series	Qty.	Description	OR	Part No.	Description
4605, 4607, 4609, 4611	3970	RT	1	5/16-18 x 1.75" Flanged Hex Head Bolt Assembly		9760	Roll Pin
	3753	RT	1	5/16-18 x 2.00" Flanged Hex Head Bolt			
4606, 4608, 4610	13-3945	RT	1	M8 x 1.25" BHSCS			
	3963	RT	1	M8 x 1.25" Flanged Hex Nut			
				M8 x 50.00mm Flanged Hex Head Bolt			

Part Description:

The standard tube insert kit with hex nut is used to make strong connections between Ready Tube profiles. It is comprised of a standard tube insert, two flanged hex head bolts and a flanged hex nut and is used to connect profiles together when their lengths are divisible by 1.50". The standard tube insert kit with hex nut requires no additional hardware or machining services. Ready Tube is also available without pre-drilled holes; fastening these profiles will require machining services.

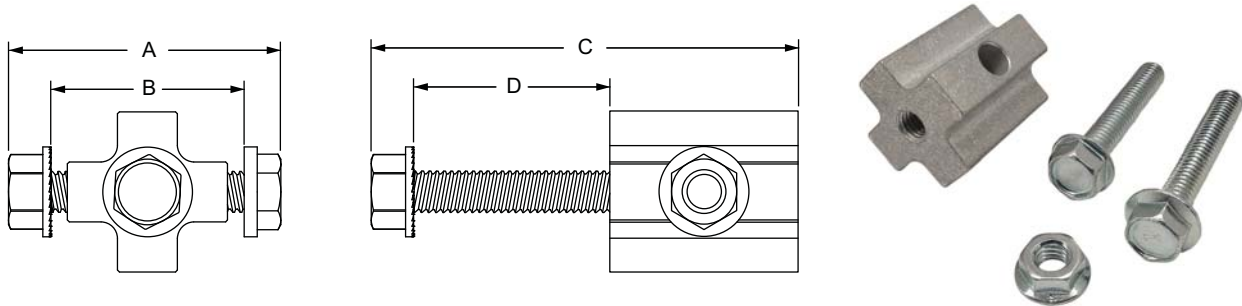

Part No.	Series	Material	Finish	Thread	A	B	C	D	Weight
4701	RT	Aluminum	Mill	5/16-18	2.062"	1.500"	3.226"	1.500"	.219 lb
4701-Black	RT		Black Anodize	5/16-18	2.062"	1.500"	3.226"	1.500"	.219 lb

Included Hardware

Insert	Part No.	Series	Qty.	Description
4701	4600	RT	1	5/16-18 Standard Tube Insert
	3970	RT	1	5/16-18 x 1.75" Flanged Hex Head Bolt Assembly
	3753	RT	1	5/16-18 x 2.00" Flanged Hex Head Bolt

Standard Tube Insert Kit with Hex Nut

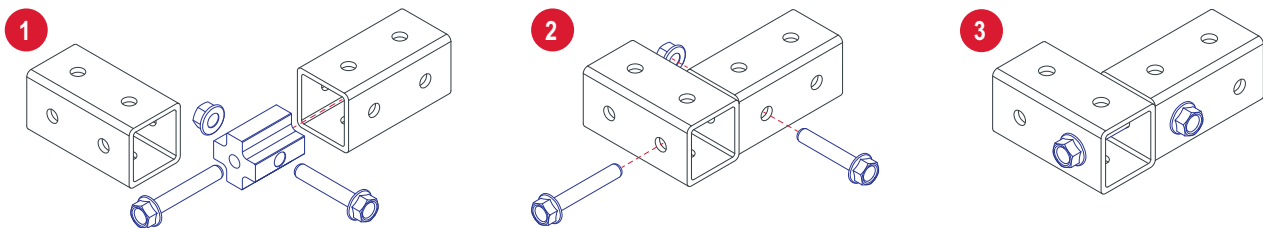

Standard Tube Insert Kit with Roll Pin

Part Description:

The standard tube insert kit with roll pin is used to make strong connections between Ready Tube profiles. It is comprised of a standard tube insert, one flanged hex head bolts and a roll pin and is used to connect profiles together when their lengths are divisible by 1.50". The roll pin provides a smooth, clean finish and eliminates the use of protruding hardware. The standard tube insert kit with roll pin requires no additional hardware or machining services. Ready Tube also is available without pre-drilled holes; fastening these profiles will require machining services. Use a roll pin punch to install this product (page 907).

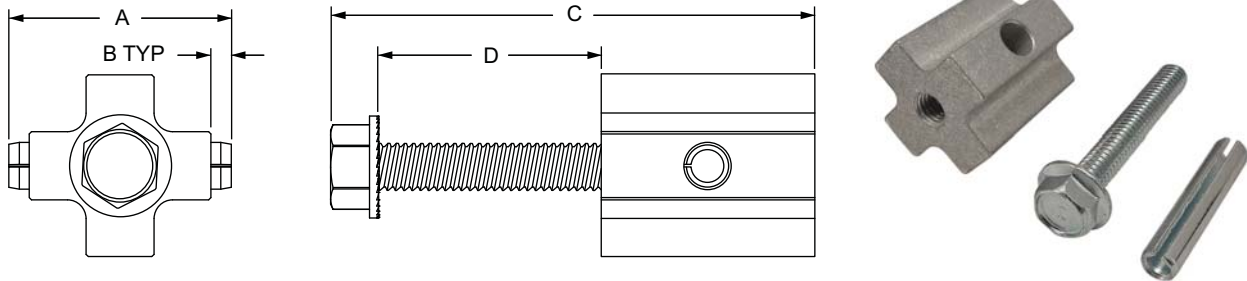

Part No.	Series	Material	Finish	Thread	A	B	C	D	Weight
4700	RT	Aluminum	Mill	5/16-18	1.500"	.138"	3.226"	1.500"	.186 lb
4700-Black	RT		Black Anodize	5/16-18	1.500"	.138"	3.226"	1.500"	.186 lb
4702	RT		Mill	M8 x 1.25"	1.500"	.138"	3.226"	1.500"	.186 lb
4702-Black	RT		Black Anodize	M8 x 1.25"	1.500"	.138"	3.226"	1.500"	.186 lb

Included Hardware

Insert	Part No.	Series	Qty.	Description
4700	4600	RT	1	5/16-18 Standard Tube Insert
	9760	RT	1	Roll Pin
	3753	RT	1	5/16-18 x 2.00" Flanged Hex Head Bolt
4702	4601	RT	1	M8 x 1.25" Standard Tube Insert
	9760	RT	1	Roll Pin
	13-3753	RT	1	M8 x 50.00mm Flanged Hex Head Bolt

Standard Tube Insert Kit with Roll Pin

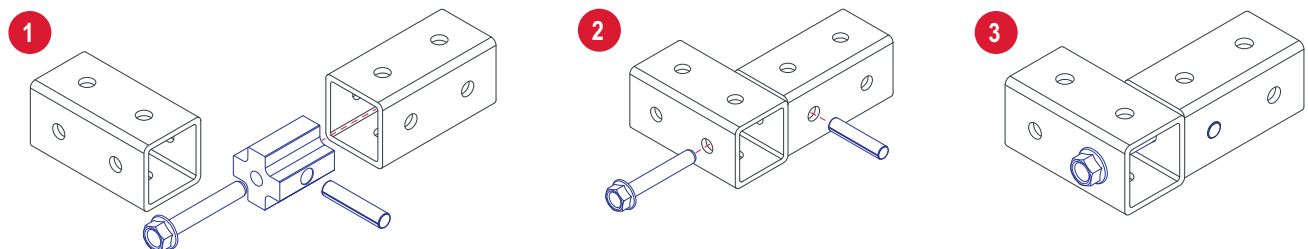

Part Description:

The roll pin is commonly used with the standard or extended insert to make strong connections between Ready Tube profiles. The roll pin provides a smooth, clean finish and eliminates the need for protruding hardware when used with the standard insert. Use a roll pin punch to install this product (page 907). For information on the standard tube insert kit with roll pin see page 420.

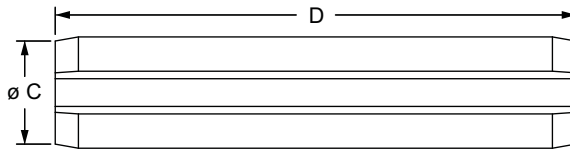
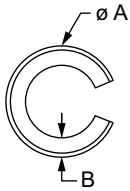

Part No.	Series	Material	Finish	A	B	C	D	Weight
9760		Steel	Bright Zinc	.341"	.059"	.315"	1.500"	.019 lb

Standard Tube Insert Kit with Roll Pin

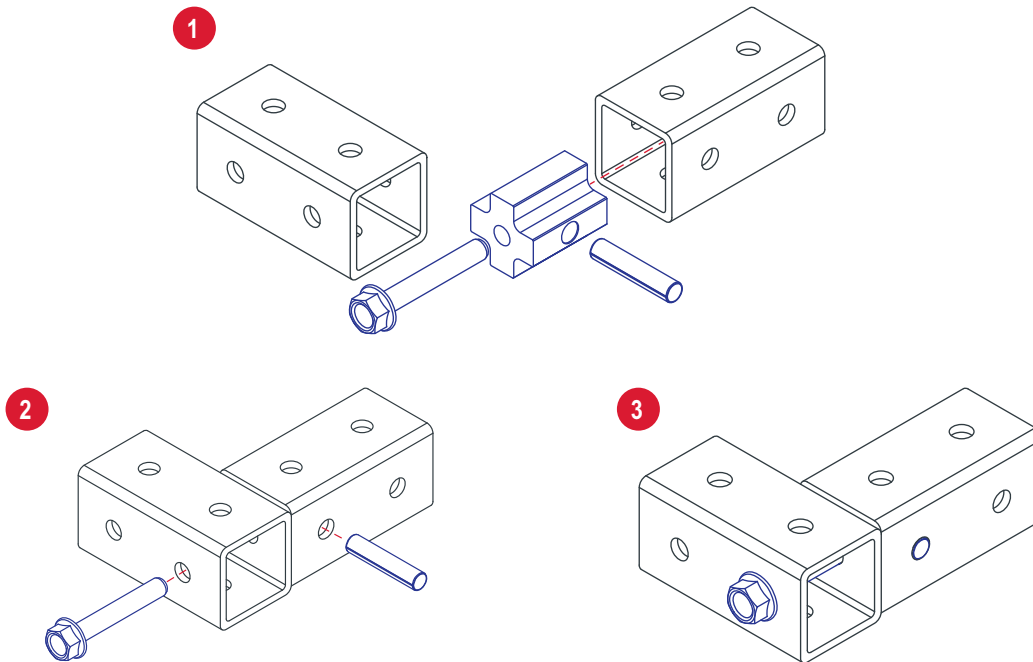

Anti-Rotation Plate

Part Description:

The anti-rotation plate is used with flanged Ready Tube profiles to prevent offset loads from twisting. It is aluminum, making it a strong and durable option. See below for the suggested hardware to mount the plate to a Ready Tube profile.

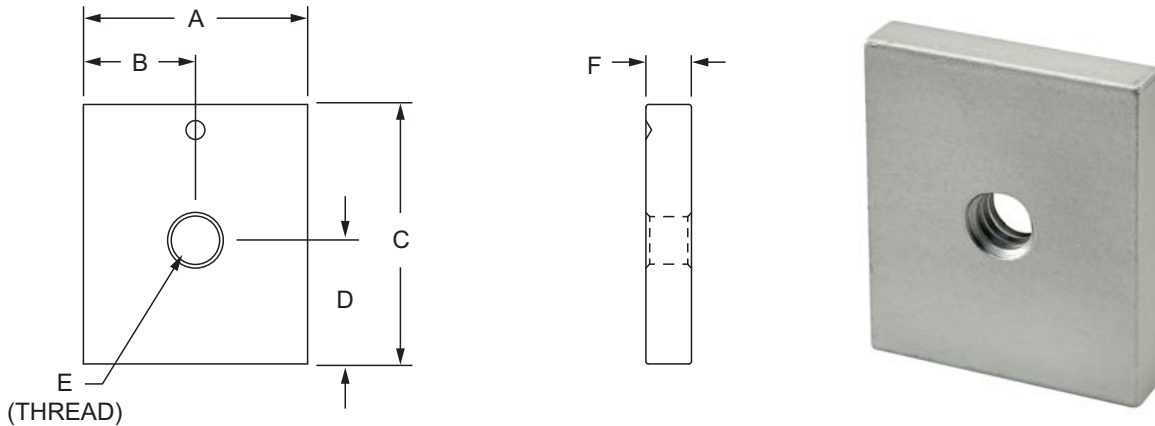

Part No.	Series	Material	Finish	A	B	C	D	E (Thread)	F	Weight
4625		Aluminum	Clear Anodize	1.230"	.615"	1.490"	.745"	5/16-18	.250"	.044 lb
4625-Black			Black Anodize	1.230"	.615"	1.490"	.745"	5/16-18	.250"	.044 lb
4626			Clear Anodize	31.21mm	15.62mm	37.85mm	18.92mm	M8 x 1.25	6.35mm	.042 lb
4626-Black			Black Anodize	31.21mm	15.62mm	37.85mm	18.92mm	M8 x 1.25	6.35mm	.042 lb

Suggested Hardware (Mount to RT Profile)

Part No.	Series	Qty.	Bolt
3752		1	5/16-18 x 1.75" Flanged Hex Bolt
13-3945		1	M8 x 1.25 BHSCS

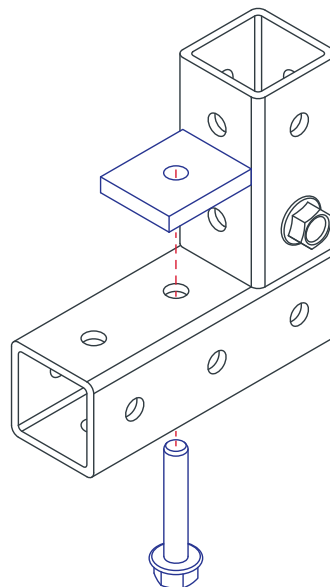

Part Description:

The 2 way - butt connector is made of nylon and is used with a Quick Frame profile which has built-in ridges that bite into the fastener to create tension without the use of additional hardware. It connects profiles and provides a clean, flush connection quickly and easily using only a soft-faced mallet (page 906) to form light-duty yet sturdy builds. The 2 way - butt connector can also be used to connect shorter bars together where logistics or space makes it difficult to maneuver longer profiles. It requires no additional hardware and no machining services.

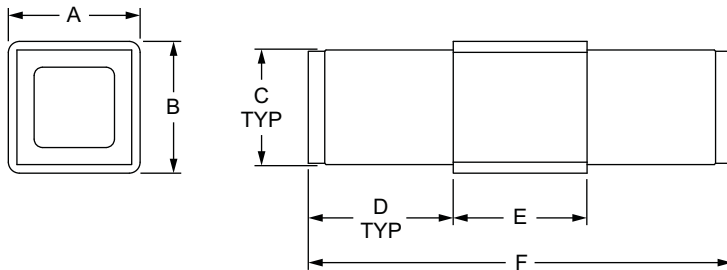

Part No.	Series	Material	Process	Color	A	B	C	D	E	F	Weight
9115	QF	Nylon	Injection Molded	Gray	1.100"	1.100"	.870"	1.100"	1.000"	3.200"	.061 lb
9215	QF			Black	1.100"	1.100"	.870"	1.100"	1.000"	3.200"	.059 lb

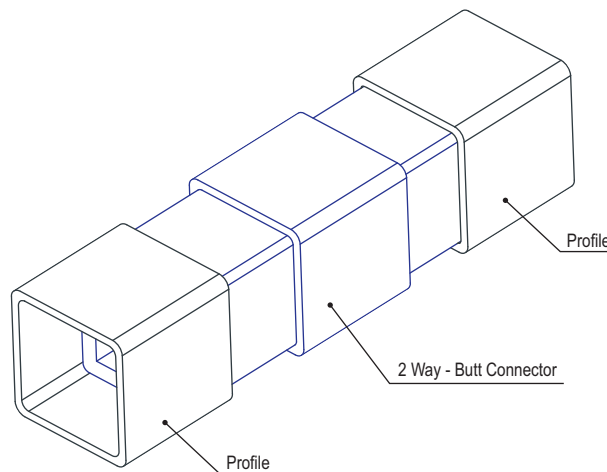

2 Way - Corner Connector

Part Description:

The 2 way - corner connector is made of nylon and is used with a Quick Frame profile which has built-in ridges that bite into the fastener to create tension without the use of additional hardware. It provides a 90 degree flush connection quickly and easily using only a soft-faced mallet (page 906) to form light-duty yet sturdy builds. The 2 way - corner connector is commonly used when transitioning between standard and flanged profiles. It requires no additional hardware and no machining services. Connecting flanged Quick Frame profiles at a 90 degree angle requires a 45 degree miter cut (see machining service on page 875) to connect without interference.

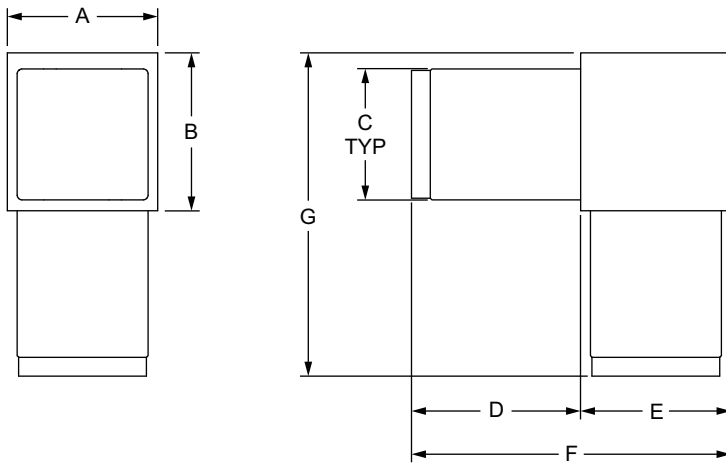

Part No.	Series	Material	Process	Color	A	B	C	D	E	F	G	Weight
9120		Nylon	Injection Molded	Gray	1.000"	1.000"	.870"	1.125"	1.000"	2.125"	2.125"	.065 lb
9220				Black	1.000"	1.000"	.870"	1.125"	1.000"	2.125"	2.125"	.061 lb

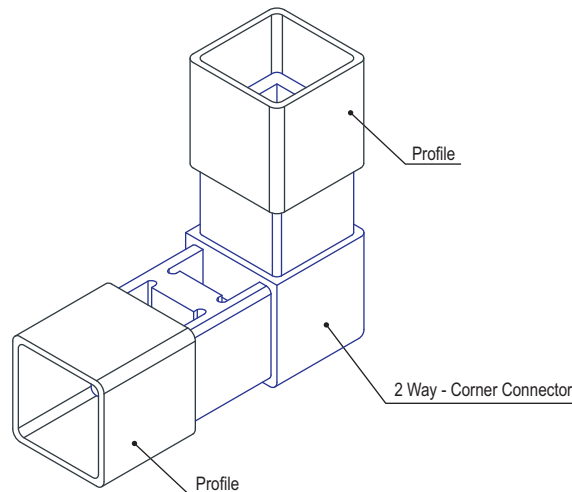

Part Description:

The 90 degree straight base connector is made of nylon and is used with a Quick Frame profile which has built-in ridges that bite into the fastener to create tension without the use of hardware. It is convenient for projects that will be attached or mounted at a 90 degree angle to any flat surface or T-slot profile and provides a clean, flush connection. The 90 degree straight base connector connects profiles quickly and easily using only a soft-faced mallet (page 906) to form light-duty yet sturdy builds.

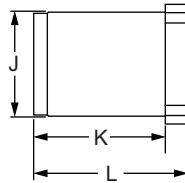
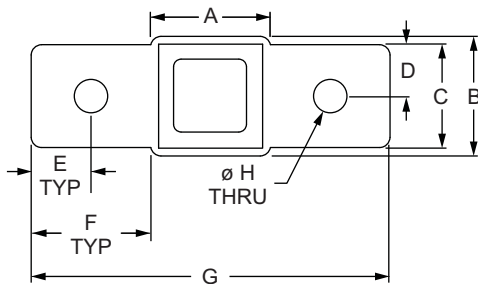

Part No.	Series	Material	Process	Color	A	B	C	D	E	F	G	H	J	K	L	Weight
9140	QF	Nylon	Injection Molded	Gray	1.000"	1.000"	.860"	.430"	.500"	1.000"	3.000"	.281"	.870"	1.100"	1.290"	.028 lb
9240	QF			Black	1.000"	1.000"	.860"	.430"	.500"	1.000"	3.000"	.281"	.870"	1.100"	1.290"	.028 lb

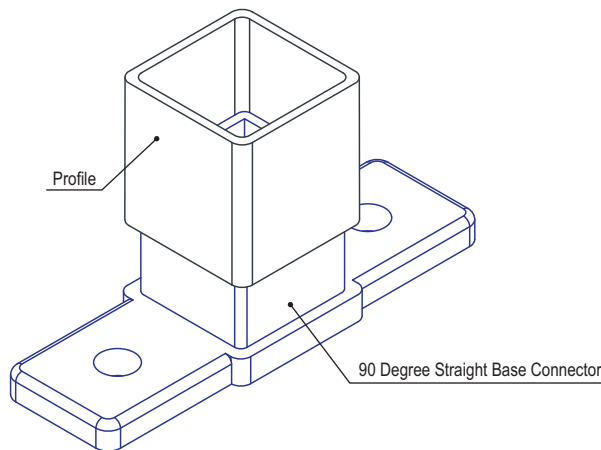

90 Degree Corner Base Connector

Part Description:

The 90 degree corner base connector is made of nylon and is used with a Quick Frame profile which has built-in ridges that bite into the fastener to create tension without the use of hardware. It is convenient for projects that will be attached or mounted at a 90 degree angle to any flat surface or T-slot profile and it also provides a corner connection. The 90 degree corner base connector attaches profiles quickly and easily using only a soft-faced mallet (page 906) to form light-duty yet sturdy builds.

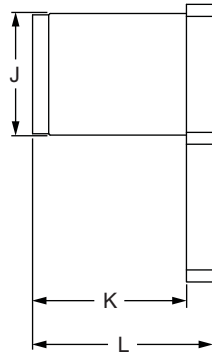
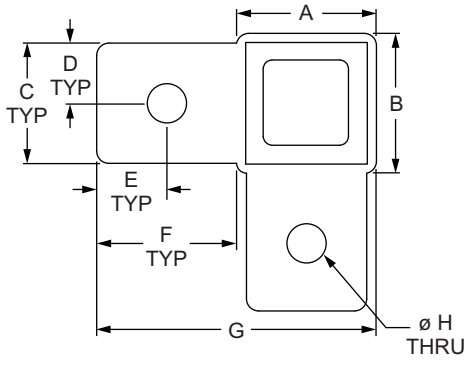

Part No.	Series	Material	Process	Color	A	B	C	D	E	F	G	H	J	K	L	Weight
9242		Nylon	Injection Molded	Black	1.000"	1.000"	.860"	.430"	.500"	1.000"	2.000"	.281"	.870"	1.100"	1.290"	.028 lb

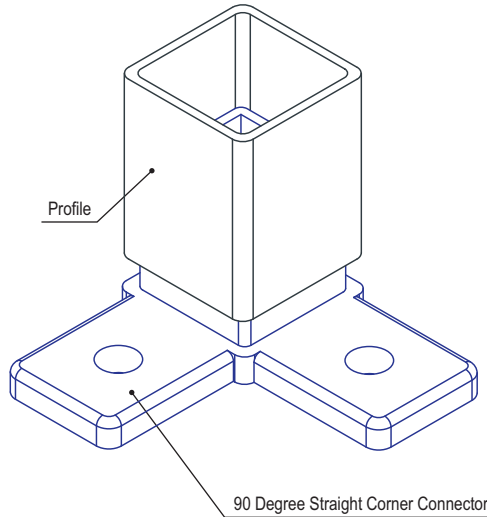

Part Description:

The 3 way - tee connector is made of nylon and is used with a Quick Frame profile which has built-in ridges that bite into the fastener to create tension without the use of hardware. It provides flush connections of up to three Quick Frame profiles using only a soft-faced mallet (page 906) to form light-duty yet sturdy builds. This fastener can connect two profiles end to end with an additional 90 degree connection and is also commonly used when transitioning between standard and flanged profiles. The 3 way - tee connector requires no additional hardware and no machining services. Connecting flanged Quick Frame profiles at a 90 degree angle requires a 45 degree miter cut (see machining service on page 875) to connect without interference.

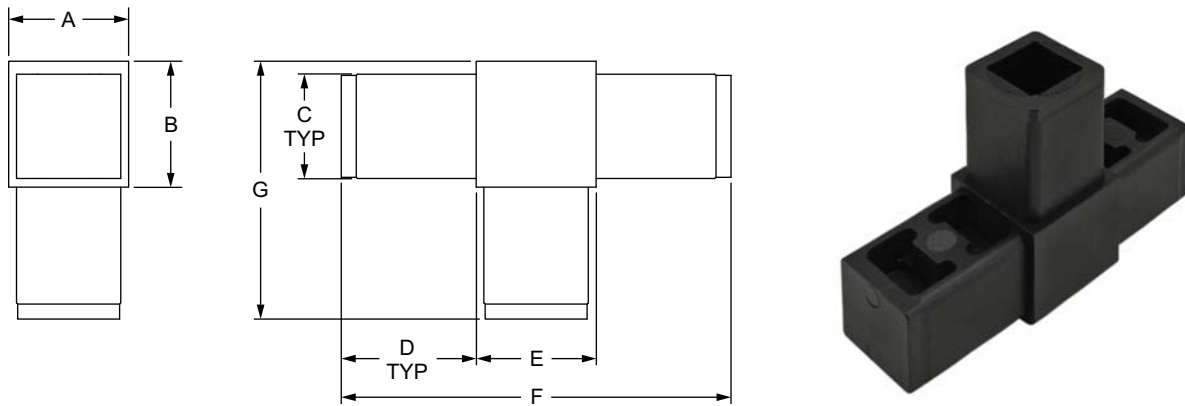

Part No.	Series	Material	Process	Color	A	B	C	D	E	F	G	Weight
9130	QF	Nylon	Injection Molded	Gray	1.000"	1.050"	.870"	1.125"	1.000"	3.250"	2.150"	.082 lb
9230	QF			Black	1.000"	1.050"	.870"	1.125"	1.000"	3.250"	2.150"	.082 lb

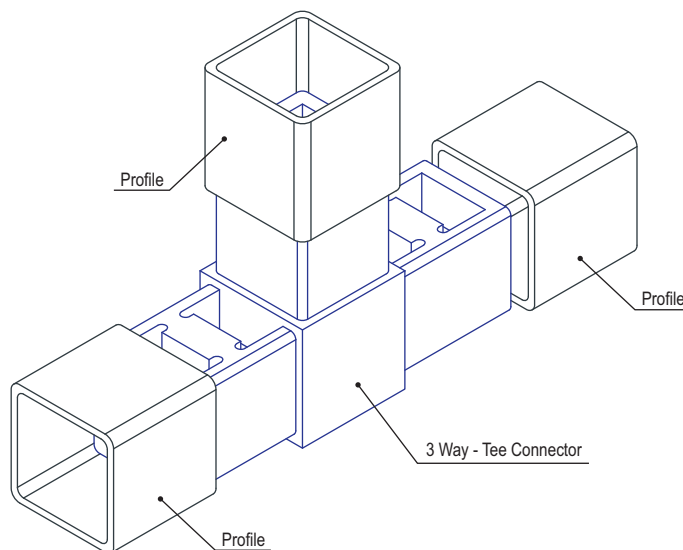

3 Way - Corner Connector

Part Description:

The 3 way - corner connector is made of nylon and is used with a Quick Frame profile which has built-in ridges that bite into the fastener to create tension without the use of additional hardware. It provides flush 90 degree connections of up to three Quick Frame profiles, convenient when you want to branch another profile off of a corner. The 3 way - corner connector is commonly used when transitioning between standard and flanged profiles and uses only a soft-faced mallet (page 906) to form light-duty yet sturdy builds. It requires no additional hardware or machining services. Connecting flanged Quick Frame profiles at a 90 degree angle requires a 45 degree miter cut (see machining service on page 875) to connect without interference.

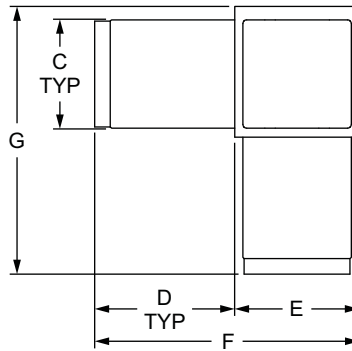
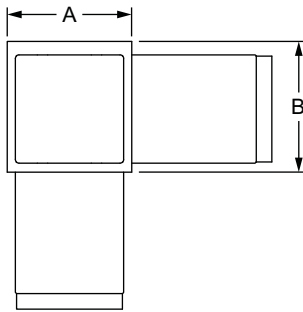

Part No.	Series	Material	Process	Color	A	B	C	D	E	F	G	Weight
9150	QF	Nylon	Injection Molded	Gray	1.000"	1.000"	.870"	1.125"	1.000"	2.125"	2.100"	.099 lb
9250	QF			Black	1.000"	1.000"	.870"	1.125"	1.000"	2.125"	2.100"	.080 lb

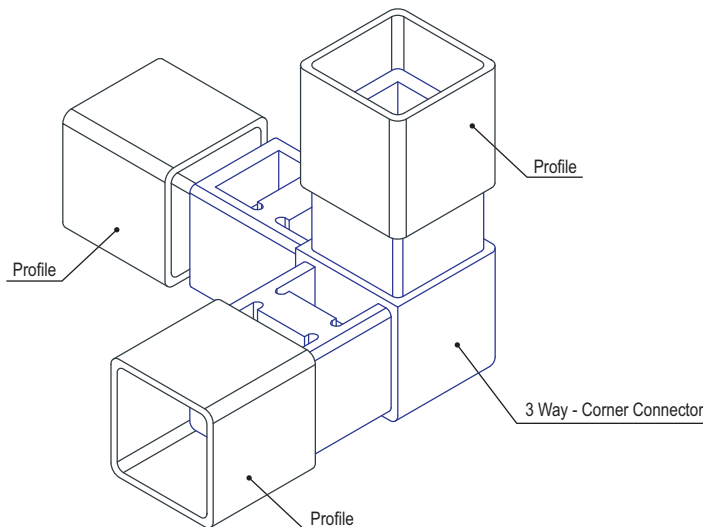

FASTENERS

Part Description:

The 4 way - cross connector is made of nylon and is used with a Quick Frame profile which has built-in ridges that bite into the fastener to create tension without the use of additional hardware. It provides flush connections of up to four Quick Frame profiles, forming 90 degree or 180 degree connections. The 4 way - cross connector is commonly used when transitioning between standard and flanged profiles and uses only a soft-faced mallet to form light-duty yet sturdy builds. It requires no machining services or additional hardware.

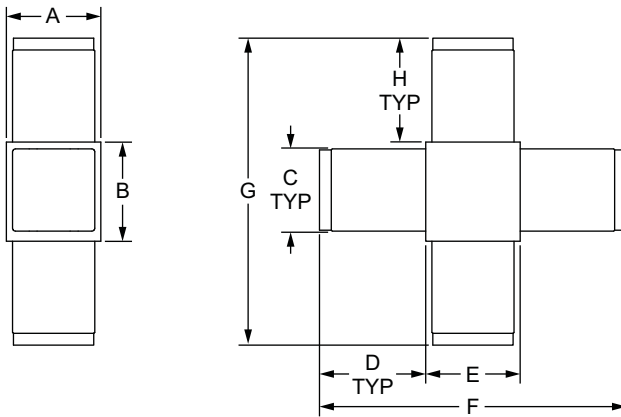

Part No.	Series	Material	Process	Color	A	B	C	D	E	F	G	H	Weight
9160	QF	Nylon	Injection Molded	Gray	1.000"	1.000"	.870"	1.125"	1.000"	3.250"	2.100"	1.110"	.124 lb
9260	QF			Black	1.000"	1.000"	.870"	1.125"	1.000"	3.250"	2.100"	1.110"	.099 lb

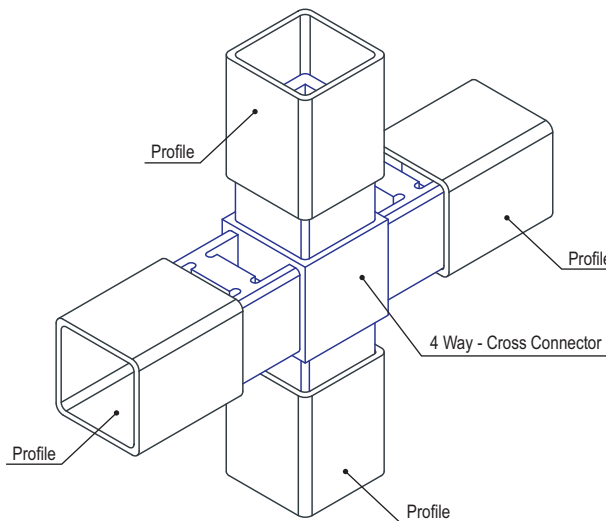

4 Way - Corner Connector

Part Description:

The 4 way - corner connector is made of nylon and is used with a Quick Frame profile which has built-in ridges that bite into the fastener to create tension without the use of additional hardware. It provides flush connections of up to four Quick Frame profiles, forming 90 degree or 180 degree connections. The 4 way - corner connector is convenient when you want to branch another profile off of a corner or straight line. The 4-way corner connector is commonly used when transitioning between standard and flanged profiles and uses only a soft-faced mallet to form light-duty yet sturdy builds. It requires no machining services or additional hardware.

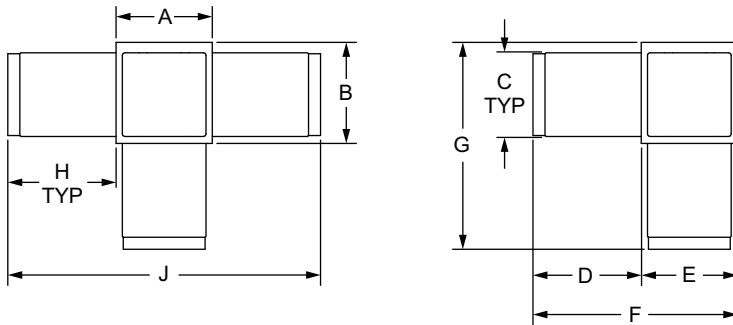

Part No.	Series	Material	Process	Color	A	B	C	D	E	F	G	H	J	Weight
9170	QF	Nylon	Injection Molded	Gray	1.000"	1.000"	.870"	1.125"	1.000"	2.125"	2.100"	1.125"	3.250"	.100 lb
9270	QF			Black	1.000"	1.000"	.870"	1.125"	1.000"	2.125"	2.100"	1.125"	3.250"	.100 lb

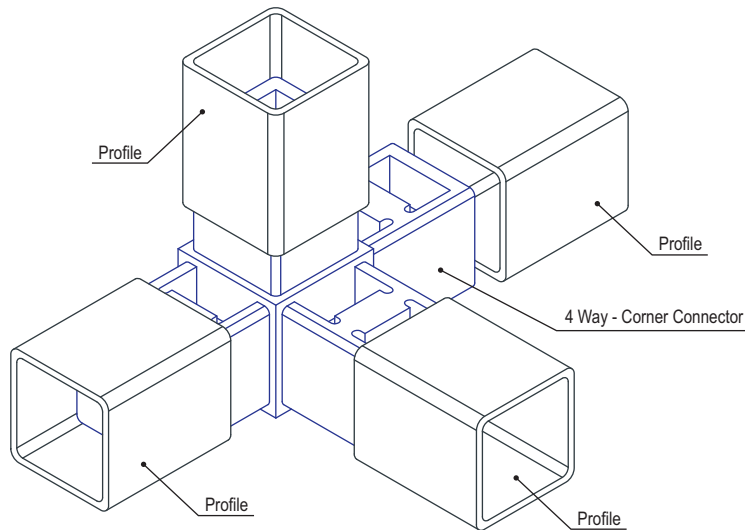

Part Description:

The 5 way - junction connector is made of nylon and is used with a Quick Frame profile which has built-in ridges that bite into the fastener to create tension without the use of additional hardware. It provides flush connections of up to five Quick Frame profiles, forming 90 degree or 180 degree connections. The 5 way - junction connector is commonly used when transitioning between standard and flanged profiles and uses only a soft-faced mallet (page 906) to form light-duty yet sturdy builds. It requires no additional hardware and no machining services.

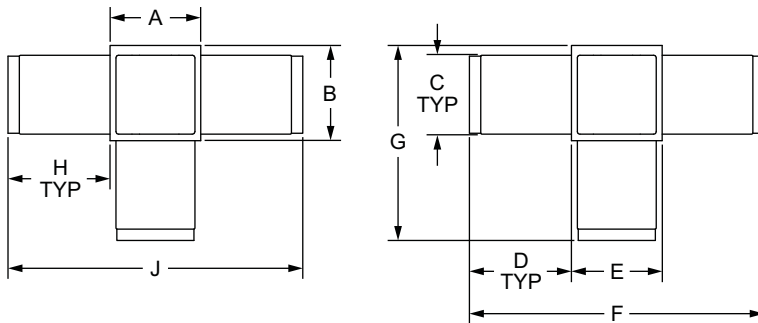

Part No.	Series	Material	Process	Color	A	B	C	D	E	F	G	H	J	Weight
9180	QF	Nylon	Injection Molded	Gray	1.000"	1.000"	.870"	1.125"	1.000"	3.250"	2.100"	1.125"	3.250"	.124 lb
9280	QF			Black	1.000"	1.000"	.870"	1.125"	1.000"	3.250"	2.100"	1.125"	3.250"	.123 lb

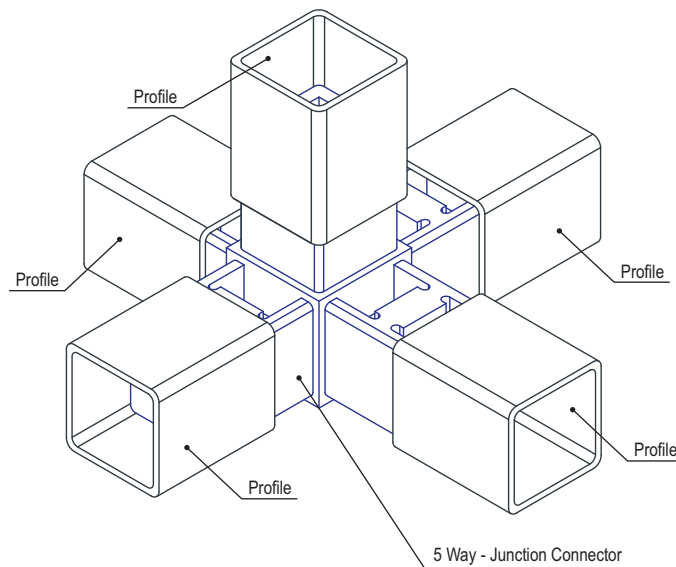

6 Way - Junction Connector

Part Description:

The 6 way - junction connector is made of nylon and is used with a Quick Frame profile which has built-in ridges that bite into the fastener to create tension without the use of additional hardware. It provides flush connections of up to six Quick Frame profiles, forming 90 degree or 180 degree connections. The 6 way - junction connector is commonly used when transitioning between standard and flanged profiles and uses only a soft-faced mallet (page 906) to form light-duty yet sturdy builds. It requires no additional hardware and no machining services.

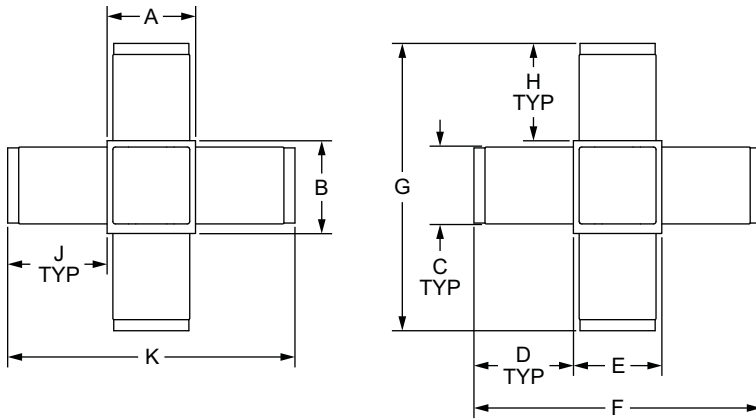

Part No.	Series	Material	Process	Color	A	B	C	D	E	F	G	H	J	K	Weight
9190	QF	Nylon	Injection Molded	Gray	1.000"	1.000"	.870"	1.125"	1.000"	3.250"	3.200"	1.100"	1.125"	3.250"	.135 lb
9290	QF			Black	1.000"	1.000"	.870"	1.125"	1.000"	3.250"	3.200"	1.100"	1.125"	3.250"	.138 lb

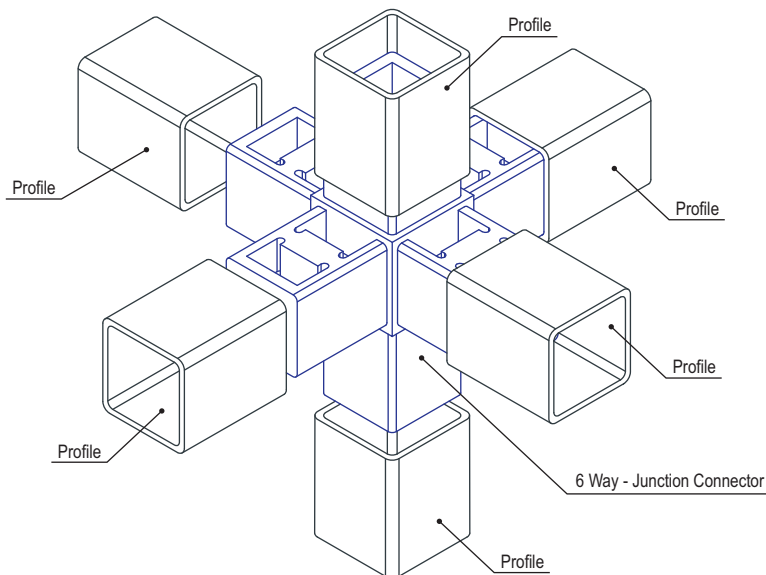

Part Description:

The caster or spacer receptacle insert is made of nylon and is used with a Quick Frame profile which has built-in ridges that bite into the fastener to create tension without the use of additional hardware. It enables the mounting of casters for mobility or the addition of spacers between profiles. The caster or spacer receptacle insert requires no machining services.

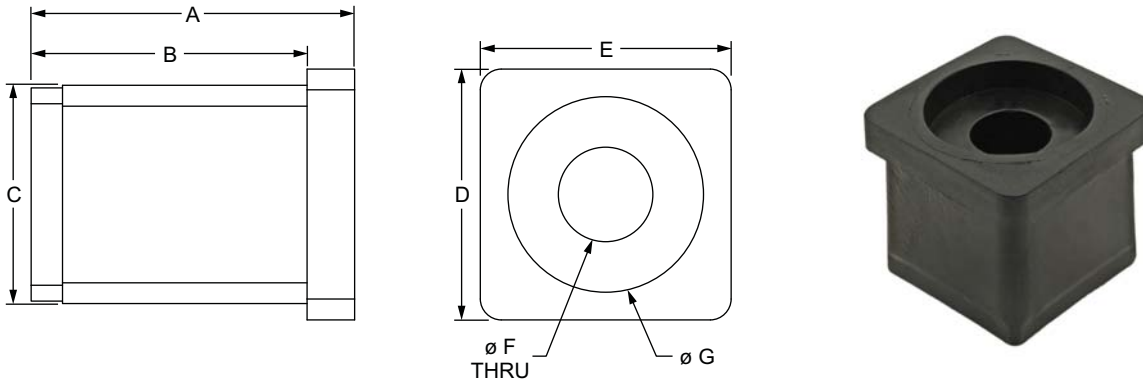

Part No.	Series	Material	Process	Color	A	B	C	D	E	F	G	Weight
9113	QF	Nylon	Injection	Gray	1.290"	1.100"	.870"	1.000"	1.000"	.375"	.780" x .190" deep	.025 lb
9213	QF		Molded	Black	1.290"	1.100"	.870"	1.000"	1.000"	.375"	.780" x .190" deep	.026 lb

Profile to Profile

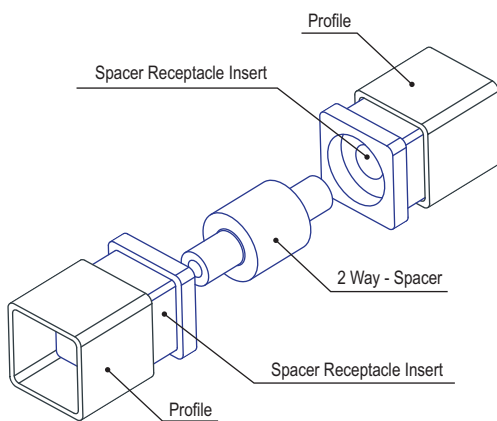

Profile to Caster

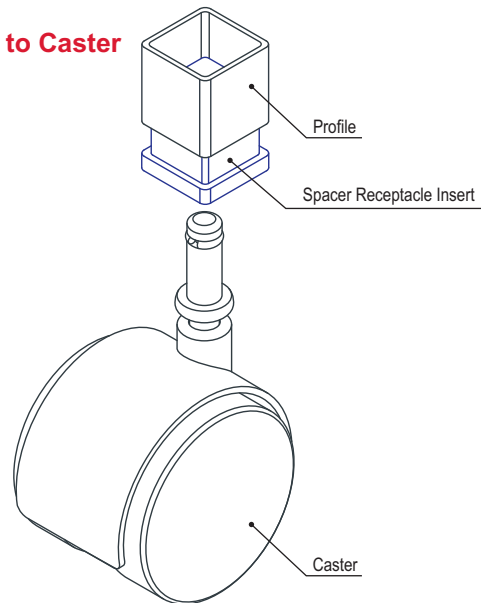

3 Way - Corner Connector with Caster or Spacer Receptacle

Part Description:

The 3 way - corner connector with caster or spacer receptacle is made of nylon and is used with a Quick Frame profile which has built-in ridges that bite into the fastener to create tension without the use of additional hardware. It enables the mounting of casters for mobility or the addition of spacers between profiles that are in a corner configuration. It is commonly used for carts or mobile storage and requires no machining services.

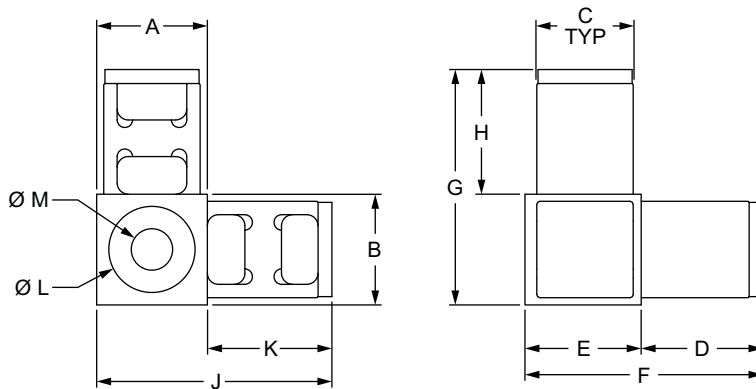

Part No.	Series	Material	Process	Color	A	B	C	D	E	F	G	H	J	K	L	M	Weight
9153	QF	Nylon	Injection Molded	Gray	1.000"	1.000"	.870"	1.100"	1.050"	1.150"	2.125"	1.125"	2.125"	1.125"	.780" x .190" deep	.375" x 1.375" deep	.092 lb
9253	QF			Black	1.000"	1.000"	.870"	1.100"	1.050"	1.150"	2.125"	1.125"	1.125"	2.125"	1.125"	.780" x .190" deep	.375" x 1.375" deep

Profile to Profile

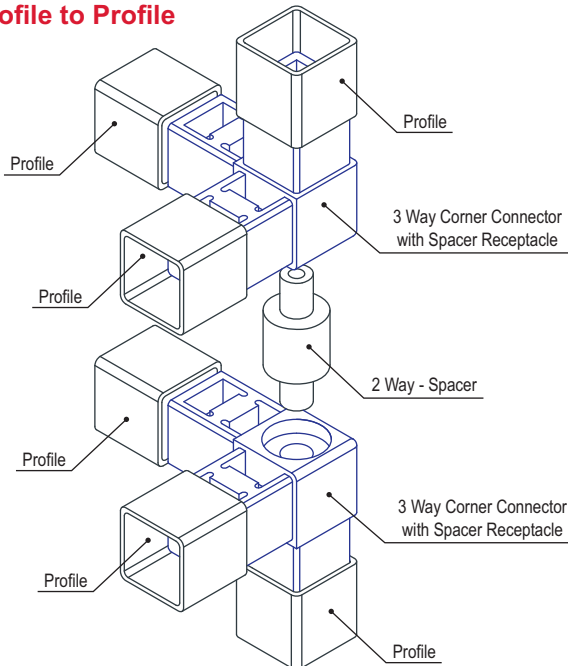

Profile to Caster

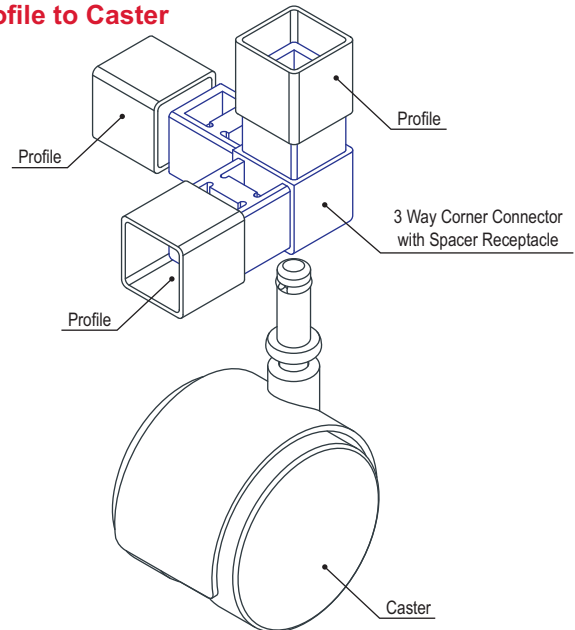

Part Description:

The 2 way - spacer is made of nylon and fits into a spacer receptacle insert (page 433) to create tension. It adds space between Quick Frame profiles to form varying lengths of bars and can also be used to provide a stable pivot for door applications. The 2 way - spacer connects profiles quickly and easily using only a soft-faced mallet to form light-duty yet sturdy builds. It requires no machining services.

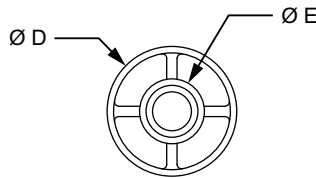
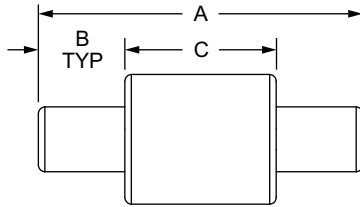

Part No.	Series	Material	Process	Color	A	B	C	D	E	Weight
9198	QF	Nylon	Injection Molded	Gray	1.875"	.500"	.870"	.770"	.375"	.013 lb

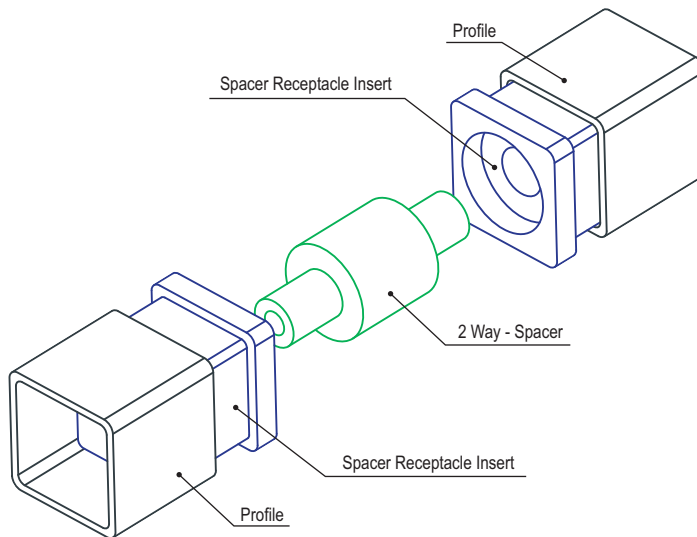

3 Way - Hexagon Segment Connector

Part Description:

The 3 way - hexagon segment connector is made of nylon and is used with a Quick Frame profile which has built-in ridges that bite into the fastener to create tension without the use of additional hardware. It creates a unique corner connection perfect in guarding and display applications and can be used with other connectors to create an enclosure. The 3 way - hexagon segment connector provides flush connections of up to three Quick Frame profiles using only a soft-faced mallet (page 906) to form light-duty yet sturdy builds. It requires no additional hardware and no machining services.

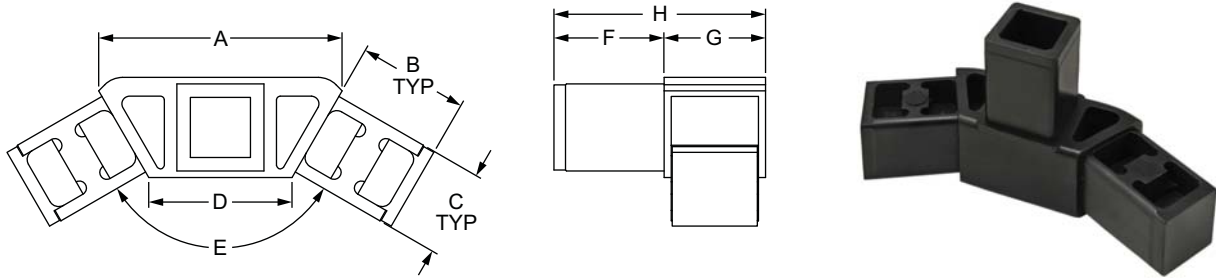

Part No.	Series	Material	Process	Color	A	B	C	D	E	F	G	H	Weight
9273		Nylon	Injection Molded	Black	2.400"	1.105"	.870"	1.375"	120°	1.100"	1.102"	2.202"	.104 lb

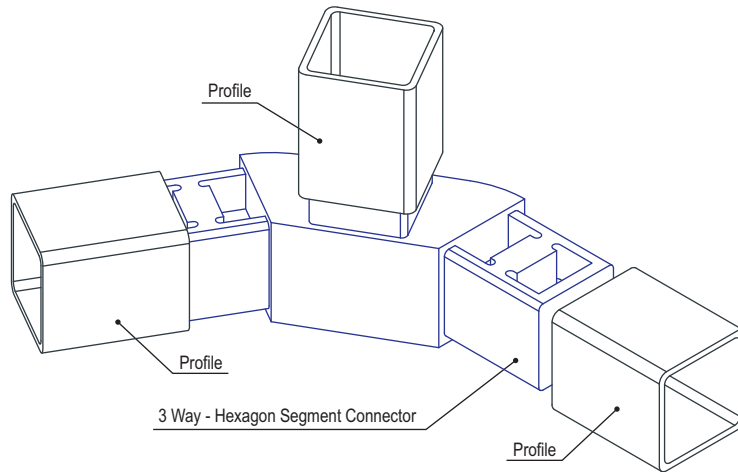

FASTENERS

80/20[®] Inc. 30 Degree Straight Hexagon Base Connector

Part Description:

The 30 degree straight hexagon base connector is made of nylon and is used with a Quick Frame profile which has built-in ridges that bite into the fastener to create tension without the use of additional hardware. It can be used in combination with other connectors to create an enclosure or to add a 30 degree angle to any project. The 30 degree straight hexagon base connector is convenient for projects that will be attached or mounted to any flat surface. It provides a flush connection using only a soft-faced mallet (page 906) to form light-duty yet sturdy builds and requires no additional hardware and no machining services.

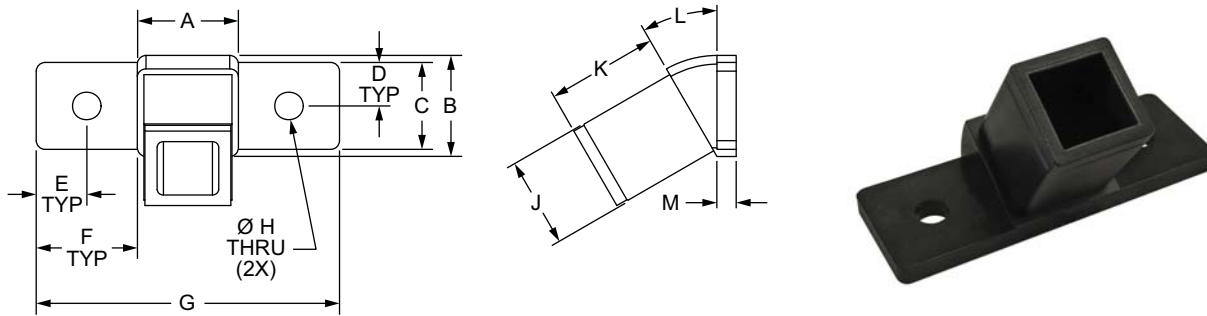

Part No.	Series	Material	Process	Color	A	B	C	D	E	F	G	H	J	K	L	M	Weight
9245	QF	Nylon	Injection Molded	Black	1.000"	1.000"	.860"	.430"	.500"	1.000"	3.000"	.281"	.870"	1.100"	30°	.190"	.043 lb

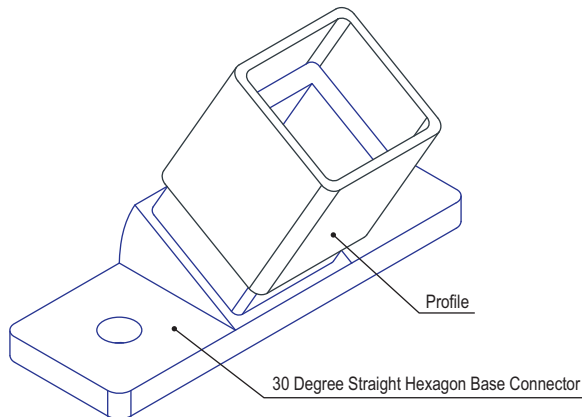

60 Degree Hexagon Side and Top Connector

Part Description:

The 60 degree hexagon side and top connector is made of nylon and is used with a Quick Frame profile which has built-in ridges that bite into the fastener to create tension without the use of additional hardware. It creates a unique connection perfect for guarding and display applications and can be used with other connectors to create an enclosure. The 60 degree hexagon side and top connector provides flush connections of up to seven Quick Frame profiles using only a soft-faced mallet (page 906) to form light-duty yet sturdy builds. The top pitch is 20 degrees. It requires no additional hardware and no machining services.

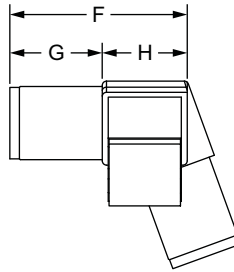
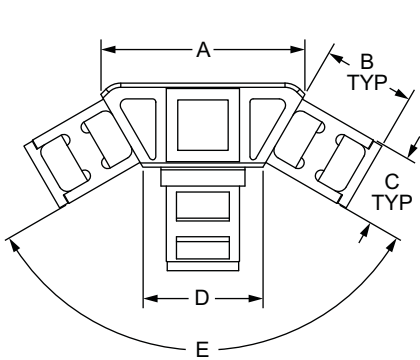

Part No.	Series	Material	Process	Color	A	B	C	D	E	F	G	H	Weight
9275	QF	Nylon	Injection Molded	Black	2.430"	1.100"	.870"	1.430"	120°	2.112"	1.100"	1.012"	.136 lb

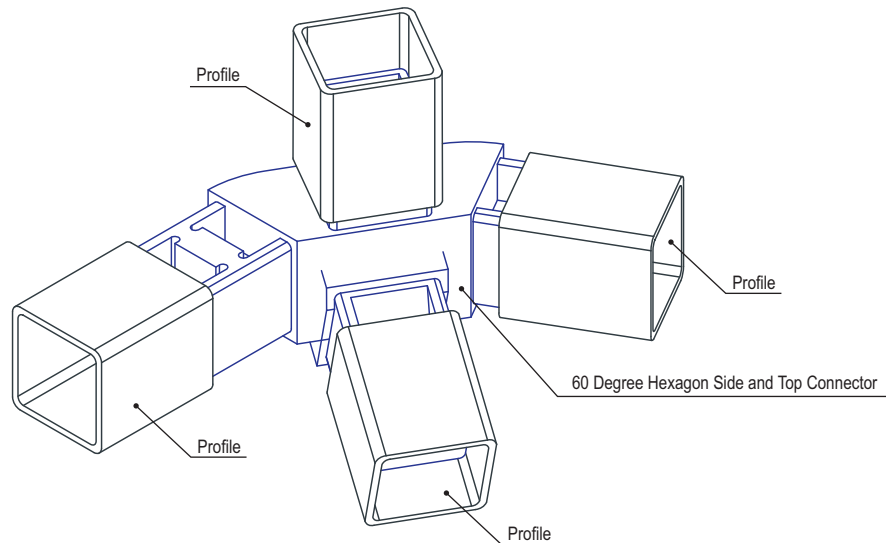

Part Description:

The 20 degree pitch hexagon connector is made of nylon and is used with a Quick Frame profile which has built-in ridges that bite into the fastener to create tension without the use of additional hardware. It creates a unique connection perfect for guarding and display applications and can be used with other connectors to create an enclosure. The 20 degree pitch hexagon connector provides flush connections of up to four Quick Frame profiles using only a soft-faced mallet (page 906) to form light-duty yet sturdy builds. It requires no additional hardware and no machining services.

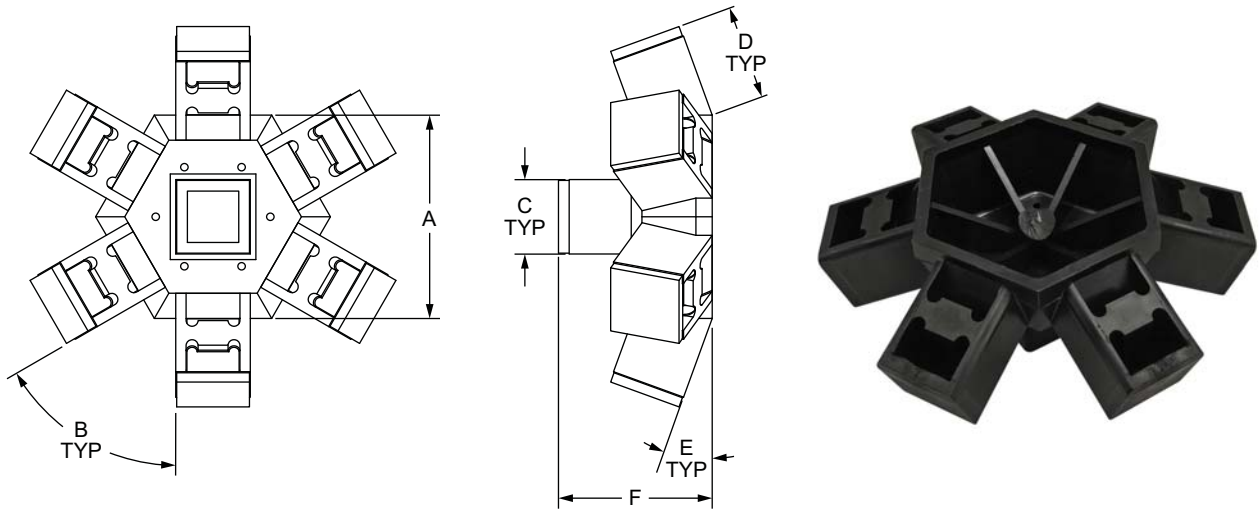

Part No.	Series	Material	Process	Color	A	B	C	D	E	F	Weight
9297	QF	Nylon	Injection Molded	Black	2.375"	60°	.870"	1.100"	20°	1.795"	.196 lb

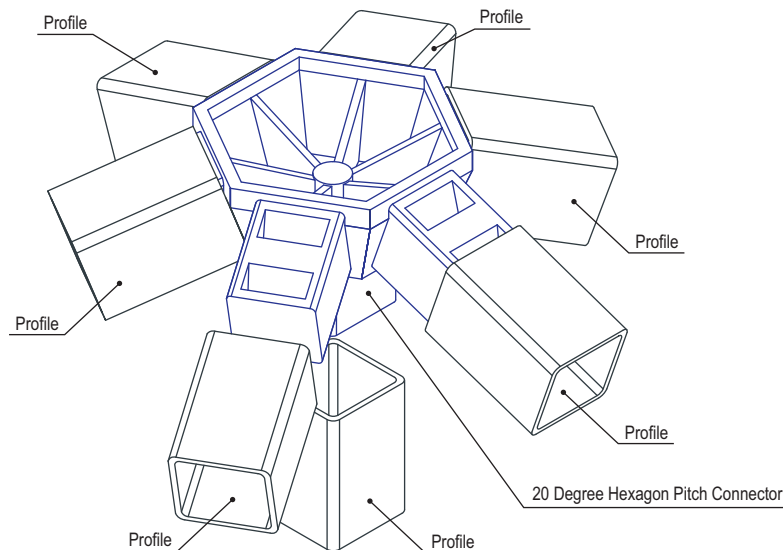

Quick Frame to 10 Series Transition Tee

Part Description:

The Quick Frame to 10 series transition tee is made of nylon and is used with a Quick Frame profile which has built-in ridges that bite into the fastener to create tension without the use of additional hardware. It is used to transition from a 1" x 1" T-slotted profile using only a soft-faced mallet (page 906) to form light-duty yet sturdy builds. The Quick Frame to 10 series transition tee requires no additional hardware and no machining services. For information on the mounting hardware for 10 series profiles see below.

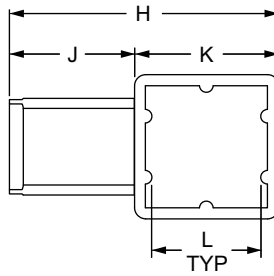
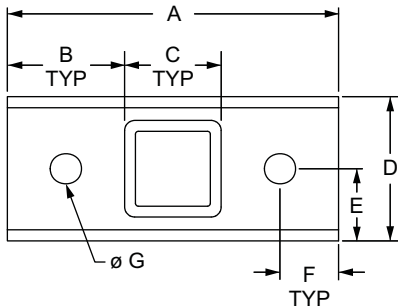

Part No.	Series	Material	Process	Color	A	B	C	D	E	F	G	H	J	K	L	Weight
9330	10 to QF	Nylon	Injection Molded	Black	3.000"	1.065"	.870"	1.300"	.650"	.528"	.281"	2.425"	1.125"	1.300"	1.000"	.077 lb

Suggested Hardware (Mount to T-Slot)

Part No.	Series	Qty.	Bolt	T-Nut
3386	10	2	1/4-20 x 3/8" FBHSCS	Slide-In

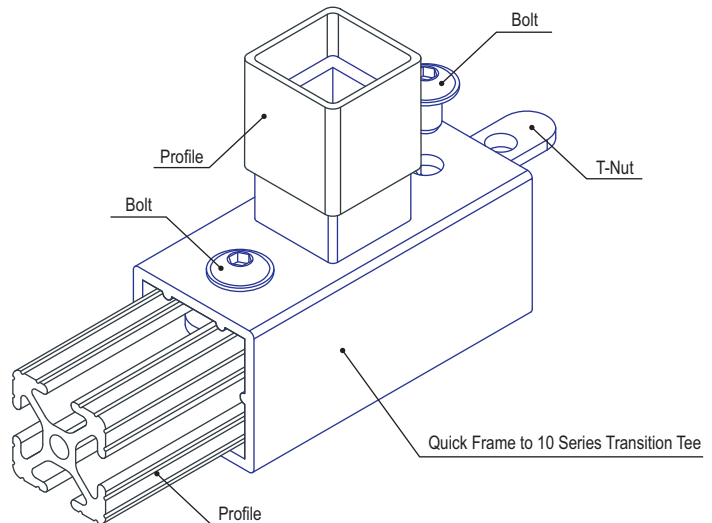

Pictorial Table Of Contents



Introduction to Panels and Doors



Page 445

Using Panels & Mesh with T-Slot



Page 446

Panel & Mesh Mounting Options

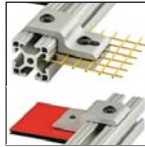

Page 447

Tips for Ordering Panels



Page 448

Motion Within the T-slot

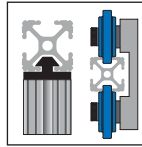

Page 448

Hinge Options



Page 449

Finishing Touches



Page 449

Panel Types

Acrylic Panels

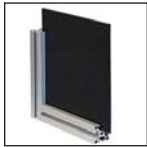

Page 450

AR Polycarbonate



Page 451

ESD Polycarbonate



Page 452

Polycarbonate

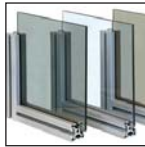

Page 453

Recycled Polycarbonate



Page 454

ABS Haircell



Page 455

Kydex[®] Panels

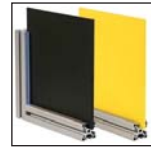

Page 456

Expanded PVC



Page 457

Alucobest[™] Panels



Page 458

Alumalite[™] Panels

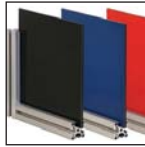

Page 459

Twin Wall Polycarbonate



Page 460

HDPE Panels

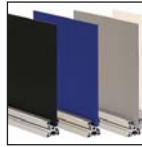

Page 461

HDPE Pegboard

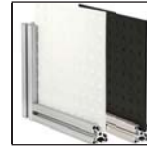

Page 462

Phenolic Resin

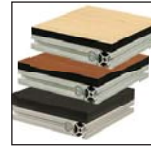

Page 463

Solid Aluminum Plate



Page 464

Diamond Tread Plate

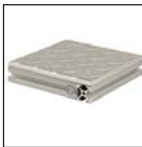

Page 465

Laminated Tabletops



Page 466

Expanded Metal

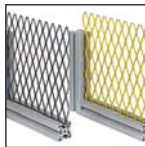

Page 467

Wire Mesh Panels

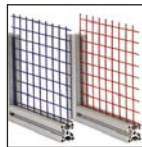

Page 468

Thermoplastic Coated Wire Mesh

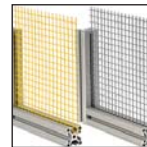

Page 469

Blocks, Clamps, Brackets, and Retainers

Detent Hinge Stopper



Page 470

Standard Panel Mount Block



Page 471

Heavy Panel Mount Block



Page 472

Lite Panel Mount Block



Page 474

Drop-in Lite Panel Mount Block



Page 475

Adjustable Panel Mount Block



Page 476

Lite Panel Mount Block Spacer



Page 477

CONTINUE



Pictorial Table Of Contents

Quick Change Panel Clamp



Page 478

Panel Mount Bracket



Page 479

Roll-in Panel Mount Bracket



Page 480

Tabletop Fastening Kit



Page 481

Single Arm Narrow Panel Retainer



Page 482

Single Arm Wide Panel Retainer



Page 484

Double Arm Narrow Panel Retainer



Page 486

Double Arm Wide Panel Retainer



Page 488

Single Arm Narrow Mesh Retainer



Page 490

Single Arm Wide Mesh Retainer



Page 492

Double Arm Narrow Mesh Retainer



Page 494

Double Arm Wide Mesh Retainer



Page 496

Narrow & Wide Backing Plate



Page 498

Single Arm Narrow Mesh Retainer with Narrow Backing Plate



Page 500

Single Arm Wide Mesh Retainer with Wide Backing Plate



Page 501

Double Arm Narrow Mesh Retainer with Narrow Backing Plate



Page 502

Double Arm Wide Mesh Retainer with Wide Backing Plate



Page 503

Single & Dual Panel Holder



Page 504

Snap On Panel Retainer



Page 505

Roll-in Mesh Panel Retainer



Page 506

Straddle Mesh Retainer & Wire Mesh Fastener



Page 507

Hinges and Roller Wheels

Economy Sliding Door Glide



Page 509

Standard Sliding Door Glide



Page 510

Standard Sliding Door Glide Profile



Page 511

Upper Door Slide Track



Page 512

Lower Door Slide Track



Page 512

Roller Wheels



Page 513

Dual Roller Wheel Bracket



Page 517

Dual Roller Wheel Bracket Assembly



Page 518

Standard Lift-Off Hinge - Right Hand with Single Long Pin



Page 519

Standard Lift-Off Hinge - Right Hand with Single Short Pin



Page 520

Standard Lift-Off Hinge - Left Hand with Single Long Pin



Page 521

Standard Lift-Off Hinge - Left Hand with Single Short Pin



Page 522

Standard Lift-Off Hinge - Mating Hub



Page 523

CONTINUE

Pictorial Table Of Contents



Standard Lift-Off Hinge with Double Short Pins



Page 524

Standard Lift-Off Hinge - Right Hand Assembly



Page 525

Standard Lift-Off Hinge - Left Hand Assembly



Page 526

Standard Captive Lift-Off Hinge Assembly



Page 527

Economy Lift-Off Hinge Right Hand with Long Pin



Page 529

Economy Lift-Off Hinge Right Hand with Short Pin



Page 530

Economy Lift-Off Hinge Left Hand with Long Pin



Page 531

Economy Lift-Off Hinge Left Hand with Short Pin



Page 532

Economy Lift-Off Hinge Assembly



Page 533

4 Hole - Concealed Hinge



Page 534

4 Hole - Plastic Lift-Off Hinge



Page 535

2 Hole - Plastic Lift-Off Hinge



Page 537

3 Hole - Plastic Double Lift-Off Hinge



Page 538

4 Hole - Dual Hand Lift-Off Hinge



Page 539

4 Hole - Adjustable Hinge



Page 540

4 Hole - Adjustable Tension Panel Hinge



Page 541

4 Hole - Detent Panel Hinge



Page 542

4 Hole - Detent Positioning Hinge



Page 543

4 Hole - Constant Friction Hinge



Page 544

4 Hole - Aluminum Hinge



Page 545

2 Hole - Standard Plastic Hinge



Page 546

4 Hole - Standard Plastic Hinge



Page 547

4 Hole - Horizontal Adjustment Plastic Hinge



Page 548

4 Hole - Standard Plastic Hinge with Snap Cover



Page 549

4 Hole - Economy Zinc Hinge



Page 550

4 Hole - Transition Hinge



Page 551

4 Hole - Standard Stainless Steel Hinge



Page 552

4 Hole - Zinc Hinge



Page 553

4 Hole - Locking Zinc Hinge



Page 554

4 Hole - Slotted Zinc Hinge



Page 555

4 Hole - Slotted Locking Zinc Hinge



Page 556

Lite Panel Hinge



Page 557

CONTINUE



Pictorial Table Of Contents

Handles and Latches

<p>Plastic Door Handle</p>  <p>Page 558</p>	<p>Offset Plastic Handle</p>  <p>Page 559</p>	<p>Ergonomic Plastic Handle</p>  <p>Page 560</p>	<p>Aluminum Door Handle</p>  <p>Page 561</p>	<p>Ready Tube Aluminum Handle</p>  <p>Page 562</p>	<p>Steel Door Handle</p>  <p>Page 563</p>	<p>Flush Plastic Panel Handle</p>  <p>Page 564</p>
<p>Aluminum Handle</p>  <p>Page 565</p>	<p>Locking Plastic Panel Grabber™ Handle</p>  <p>Page 566</p>	<p>Deluxe Door Handle with Pawl Kit</p>  <p>Page 567</p>	<p>Deluxe Door Handle Mating Handle</p>  <p>Page 568</p>	<p>Furniture Style Handle</p>  <p>Page 569</p>	<p>Furniture Style Handle Pawl Kit</p>  <p>Page 571</p>	<p>Slam Latch</p>  <p>Page 572</p>
<p>Velcro® Latch</p>  <p>Page 573</p>	<p>0 Degree Deadbolt Latch</p>  <p>Page 574</p>	<p>90 Degree Deadbolt Latch</p>  <p>Page 575</p>	<p>Grabber™ Door Catch</p>  <p>Page 576</p>	<p>Grabber™ Door Catch Mounting Plate</p>  <p>Page 577</p>	<p>Magnetic Door Catch</p>  <p>Page 579</p>	<p>Magnetic Door Catch Bracket</p>  <p>Page 580</p>
<p>Nylon Magnetic Door Catch</p>  <p>Page 581</p>	<p>Single Ball Catch</p>  <p>Page 582</p>	<p>Double Ball Catch</p>  <p>Page 583</p>	<p>Tension Ball Latch</p>  <p>Page 584</p>	<p>Sliding Door Lock</p>  <p>Page 585</p>	<p>Panel Stiffener</p>  <p>Page 586</p>	<p>Standard Panel Gasket</p>  <p>Page 587</p>
<p>Economy Panel Gasket</p>  <p>Page 588</p>	<p>Rubber Door Seal</p>  <p>Page 589</p>	<p>Wire Edge</p>  <p>Page 590</p>	<p>Aluminum Door Stop</p>  <p>Page 591</p>	<p>Nylon Door Stop</p>  <p>Page 592</p>		

Introduction to Panels & Doors

80/20 has an extensive in-house panel shop with a wide variety of wire, mesh and plastic panels. Our panels are frequently integrated into design plans and builds. They are great for guarding, enclosures, desk tops and shelves, among other applications. 80/20 carries an impressive stock of almost 100 panels in different sizes, shapes, thicknesses, colors, and materials. Keep in mind that 80/20 mesh, plastic panels, and aluminum plates are ordered by the square foot or square meter.

When deciding on your panel you'll want to make a thorough assessment of your needs. You will find that you have several choices to consider when incorporating paneling into your projects.

WHAT FITS YOUR PROJECT

OPTICAL CLARITY

- ESD Polycarbonate
- AR Polycarbonate
- Polycarbonate
- Acrylic

WEATHER RESISTANCE

- Twin Wall Polycarbonate
- Expanded PVC
- Alucobest™
- Acrylic

TEXTURED

- HDPE
- Kydex®
- ABS Haircell
- Diamond Tread Plate

IMPACT RESISTANCE

- Kydex®
- Alucobest™
- Alupalite™
- Polycarbonate
- AR Polycarbonate
- Aluminum Plate

CHEMICAL RESISTANCE

- HDPE
- Acrylic
- Alucobest™
- Alupalite™
- Expanded PVC
- Aluminum Plate

MACHINABILITY

- HDPE
- Acrylic
- Polycarbonate
- ABS Haircell
- Expanded PVC
- Alupalite™

Expanded Metal & Wire Mesh

Expanded metal and wire mesh panels work well for guarding and enclosure applications where air flow is required. They provide a barrier and can be used to block off a machine, supplies, inventory, or equipment while still providing visual access. They are strong yet lightweight and are available in a range of materials and colors.

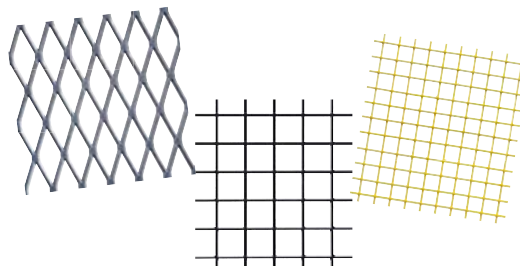

How Panels Are Used with T-Slot

80/20 panels and mesh retainers can be used a couple different ways with T-slot profiles. You can either rest the panel in the T-slot or mount it flush with the T-slot profile. Guarding, enclosures, and access points lend themselves well to panels that rest within the profile while desks and furniture applications commonly have flush panels.

Tip: When sizing a panel that will be inserted into the T-slot, be sure to add extra material to your visible panel size.

Quick Frame: For flanged Quick Frame subtract 0.14" of the visible panel size.

Series	Add
10	.500"
15	.750"
20	10mm
25	14mm
30	15mm
40	22mm
45	24mm

Panel & Mesh Mounting Options

You have several options when it comes to mounting your panels and mesh. Consider your application; Is it being used to keep things in or out or both? Are you using a mesh panel? Will you be changing out the panel often? Will the project be used inside or outside?

The answer to these questions will help determine the type of mounting option you will want to use.



Retainers



Blocks



Gasket

Retainers are easy to use and available in several sizes and shapes to fit your needs.

Panel Retainers:

- Strong
- Cost-effective
- Corrosion-resistant
- Indoor or Outdoor Use
- Requires drill-through hole in panel

Mesh Retainers:

- Strong
- Cost-effective
- Corrosion-resistant
- Indoor or Outdoor Use
- Includes a backing plate
- No machining required
- Slotted holes for adjustability

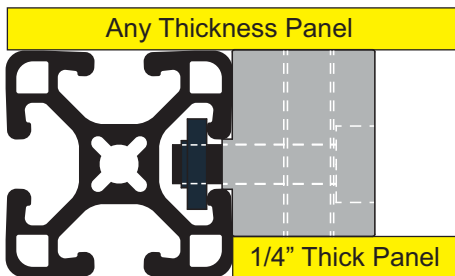
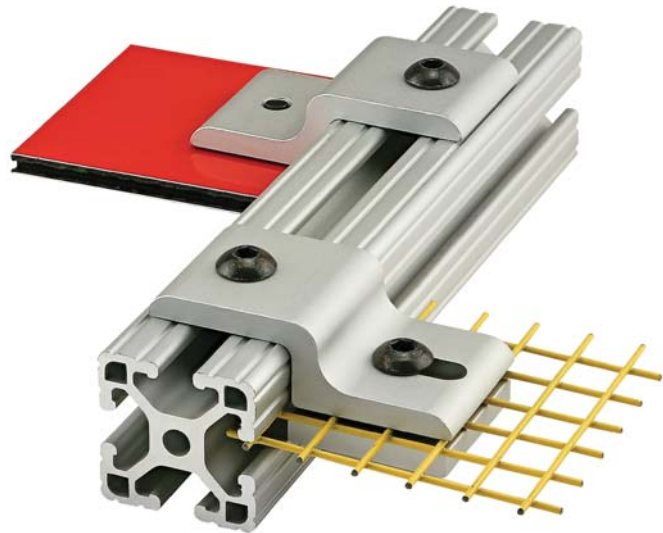

Panel Mount Blocks are a great way to mount your panel either flush with the profile or on the profile surface. They provide stability while reducing vibration and there are options available in aluminum or nylon.

Panel Gasket is a great finishing touch for your project. Use it to help secure your panel and prevent it from rattling within the frame. Keep in mind that you only need to put panel gasket on one side of the panel. Here are a few other tips when using panel gasket:

- If you are having trouble installing the gasket, use a little bit of automotive vinyl protectant.
- Cut your panel gasket 2-3 inches (50-76mm) longer than the opening to make the corners stay tight.
- When installing panel gasket, begin in the middle of your panel and work your way out.

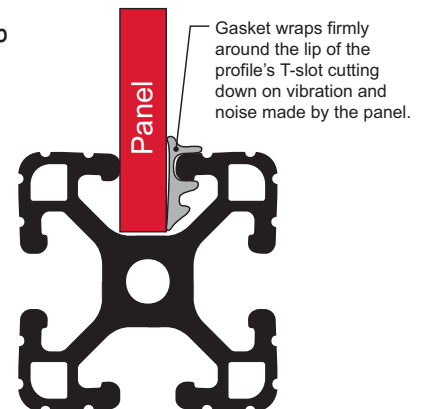

Tips for Ordering Panels

PLEASE NOTE A DRAWING IS REQUIRED

Panel Orientation:

When ordering panels it is important to indicate orientation:



Expanded Metal:

Specify horizontal or vertical diamond orientation.



Twin Wall

Polycarbonate:

Specify horizontal or vertical channel orientation.



Phenolic Resin:

Specify horizontal or vertical woodgrain orientation.

Textured Side:

Panels like Kydex[®] and ABS Haircell have a textured and smooth side. When machining is needed it's important to indicate which is outward with "T" for textured or "S" for smooth.

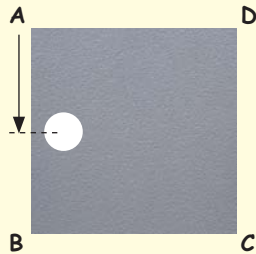

Machining Reference:

Beginning with the upper left corner, call outs are designated A, B, C, and D in a counterclockwise direction on panels. Referencing these call outs when ordering machining allows for proper measuring of the service position.

In this example, the service center line is measured down from A.

Motion within the T-slot

Door glides and roller wheels slide within the T-slot channel to enable movement of a door, panel, frame or other component. Create accessible displays or an entrance with a bi-fold door.

GLIDES

Glides are simple to use and bolt directly to a profile end to freely rotate as the door or application pivots. There is an option available that creates a bi-fold door without the use of a bottom rail.

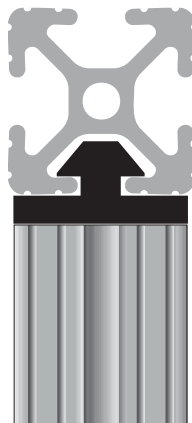

ROLLERS

Roller wheels mount directly to a T-slot or profile end and are ideal for guided linear motion. They are made of self-lubricating nylon with a permanent lubricated bushing available which reduces maintenance time and cost.

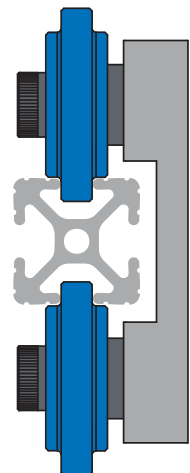

Variety of Hinge Options

80/20 offers a wide assortment of hinges in a variety of styles, materials, and sizes that can be mounted to a panel or profile to fit your requirements. From light to heavy-duty projects, there are a range of options available; choose from different materials such as plastic, zinc, or aluminum.

- Plastic hinges are typically used for lightweight doors and to connect plastic panels while aluminum hinges are a heavier-duty option.
- Lift-off hinges are popular as they can create a door that lifts off by using all right or all left lift-off hinges, or confine a door or access point by using a combination of left and right hinges.

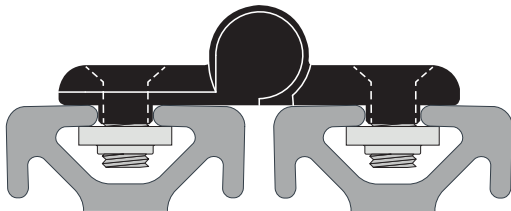

Tip: To increase its load-bearing capacity and prevent it from rotating, choose hinges with slot tabs or slot pins. If needed, the tabs and pins can be removed when, for example, a panel is being mounted.



Finishing Touches, Handles & More

80/20 has a wide range of handles, locks and catches for your door or access point. Start off by deciding how frequently the door will be in use and whether you will want it to be locked.



Unlocked



Locked

If people will be using it often, consider ergonomic handles or offset handles that hinder finger-pinching injuries. There are also flush handles to prevent snags or heavy-duty latches for larger doors or magnetic catches to help ensure a connection.



Acrylic Panels

Part Description:

Acrylic panels are a cost-effective lightweight option that provides high optical clarity. It is stable up to 180 degrees Fahrenheit and weather resistant, making it ideal for both indoor and outdoor applications. Acrylic is more impact resistant than glass while being half the weight. It is easily machined and comes in a range of colors and thicknesses. This panel is commonly used in displays, signs, furniture and partitions.

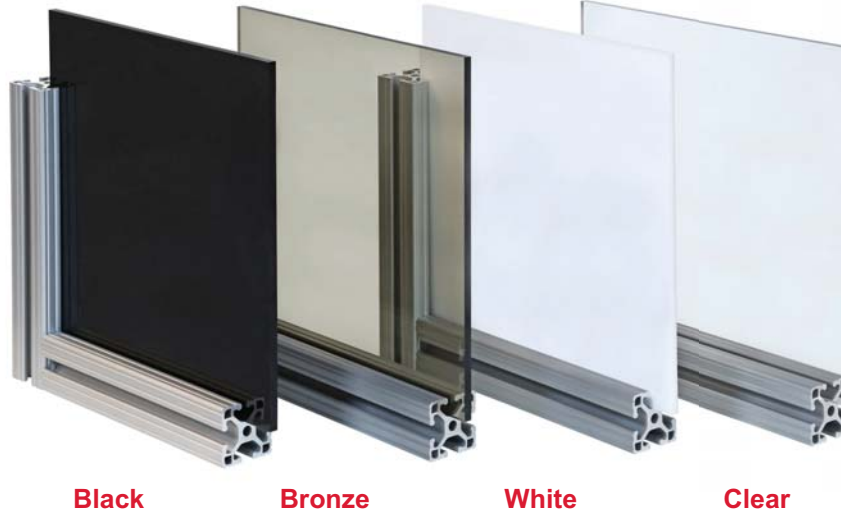

Part No. (Metric)	Series	Color	Material	Thickness	Stock Sheet Size	Weight
2601 (65-2601)	F M	Clear	Acrylic	.220 - .236" (6mm)	48" x 96" + .250/-0 (1219.2mm x 2438.4mm + 6.35/-0)	1.450 lb / ft ² (6.24 kg / m ²)
2602 (65-2602)	F M	Clear		.177" (4.5mm)		.840 lb / ft ² (5.22 kg / m ²)
2603 (65-2603)	F M	White		.220 - .236" (6mm)		1.450 lb / ft ² (6.53 kg / m ²)
2604 (65-2604)	F M	White		.177" (4.5mm)		.840 lb / ft ² (4.87 kg / m ²)
2605 (65-2605)	F M	Black		.220 - .236" (6mm)		1.450 lb / ft ² (6.44 kg / m ²)
2606 (65-2606)	F M	Black		.177" (4.5mm)		.840 lb / ft ² (4.89 kg / m ²)
2607 (65-2607)	F M	Bronze		.220 - .236" (6mm)		1.450 lb / ft ² (6.31 kg / m ²)
2608 (65-2608)	F M	Bronze		.177" (4.5mm)		.840 lb / ft ² (4.86 kg / m ²)

Standard Machining Services

Machining Type	Reference Page
Cut-to-Size	876
Drill Thru	897



Part Description:

AR polycarbonate panels are a durable option that provides high optical clarity and impact resistance. It is more abrasion and UV resistant than polycarbonate panels and stable up to 240 degrees Fahrenheit, making it ideal for both indoor and outdoor applications. AR polycarbonate is commonly used in enclosures and safety applications in high-traffic areas.



Clear

Part No. (Metric)	Series	Color	Material	Thickness	Stock Sheet Size	Weight
2641 (65-2641)	F M	Clear	AR Polycarbonate	.177" (4.5mm)	48" x 96" + .250/-0 (1219.2mm x 2438.4mm + 6.35/-0)	1.150 lb / ft ² (5.293 kg / m ²)
2642 (65-2642)	F M	Clear		.220 - .236" (6mm)		1.500 lb / ft ² (6.672 kg / m ²)

Standard Machining Services

Machining Type	Reference Page
Cut-to-Size	876
Drill Thru	897

ESD Polycarbonate Panels

Part Description:

Electrostatic dissipative (ESD) polycarbonate panels are designed to prohibit static electricity. It is a lightweight option that has excellent impact and chemical resistance. ESD has superior clarity while being easy to machine, providing design versatility and flexibility. This panel is useful in clean room, medical, and manufacturing processes where you want to minimize the occurrence and likelihood of static shock.



Clear

Part No. (Metric)	Series	Color	Material	Thickness	Stock Sheet Size	Weight
2648 (65-2648)	F M	Clear	ESD Polycarbonate	.250" (6.35mm)	48" x 96" + .250/-0 (1219.2mm x 2438.4mm + 6.35/-0)	1.531 lb / ft ² (7.480 kg / m ²)
2649 (65-2649)	F M	Clear		.187" (4.750mm)		1.088 lb / ft ² (5.310 kg / m ²)

Standard Machining Services

Machining Type	Reference Page
Cut-to-Size	876
Drill Thru	897



Part Description:

Polycarbonate panels are durable and provide impact resistance, making it ideal for industrial applications. This panel is two hundred times stronger than glass and thirty times stronger than acrylic. It has high optical clarity while being stable up to 240 degrees Fahrenheit. Polycarbonate is easily machined with simple hand tools and resists cracking, chipping or breaking when cut or drilled.

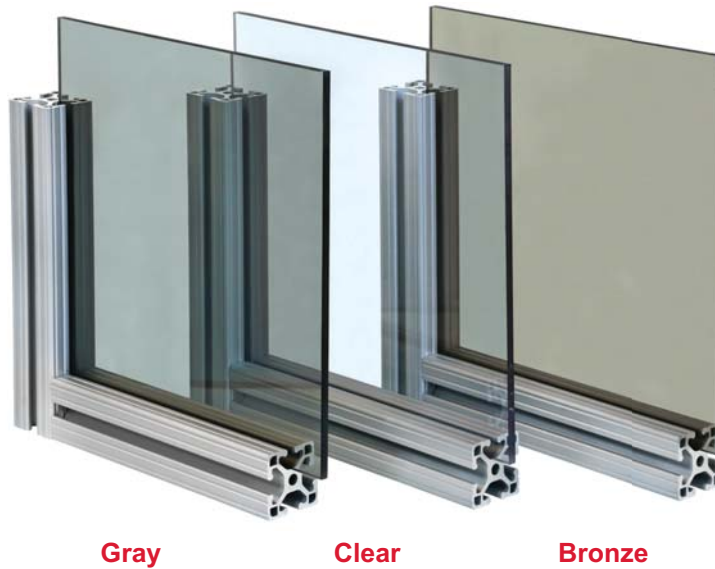

Gray

Clear

Bronze

Part No. (Metric)	Series	Color	Material	Thickness	Stock Sheet Size	Weight
2645 (65-2645)	F M	Clear	Polycarbonate	.500" (12.7mm)	48" x 96" + .250/-0 (1219.2mm x 2438.4mm + 6.35/-0)	3.120 lb / ft ² (14.586 kg / m ²)
2644 (65-2644)	F M	Clear		.375" (9.5mm)		2.340 lb / ft ² (11.017 kg / m ²)
2609 (65-2609)	F M	Clear		.220 - .236" (6mm)	48" x 96" + .250/-0 (1219.2mm x 2438.4mm + 6.35/-0) 60" x 96" + .250/-0 (1524.0mm x 2438.4mm + 6.35/-0)	1.500 lb / ft ² (6.465 kg / m ²)
2610 (65-2610)	F M	Clear		.177" (4.5mm)		1.150 lb / ft ² (5.362 kg / m ²)
2643 (65-2643)	F M	Clear		.118" (3mm)	48" x 96" + .250/-0 (1219.2mm x 2438.4mm + 6.35/-0)	.737 lb / ft ² (3.517 kg / m ²)
2611 (65-2611)	F M	Bronze		.220 - .236" (6mm)		1.500 lb / ft ² (6.965 kg / m ²)
2612 (65-2612)	F M	Bronze		.177" (4.5mm)		1.150 lb / ft ² (5.310 kg / m ²)
2629 (65-2629)	F M	Gray		.220 - .236" (6mm)		1.500 lb / ft ² (6.396 kg / m ²)
2630 (65-2630)	F M	Gray		.177" (4.5mm)		1.150 lb / ft ² (5.362 kg / m ²)

Standard Machining Services

Machining Type	Reference Page
Cut-to-Size	876
Drill Thru	897

Recycled Polycarbonate Panels

Part Description:

Recycled polycarbonate panels are durable and provide impact resistance, making it ideal for industrial applications. Polycarbonate is two hundred times stronger than glass and thirty times stronger than acrylic. This panel is made of recycled material and may appear tinted. Recycled polycarbonate panels are stable up to 240 degrees Fahrenheit, easily machined, and resists cracking, chipping or breaking when cut or drilled.



Clear

Part No. (Metric)	Series	Color	Material	Thickness	Stock Sheet Size	Weight
2646 (65-2646)	F M	Clear	Recycled Polycarbonate	.220 - .236" (6mm)	48" x 96" + .250/-0	1.500 lb / ft ² (6.517 kg / m ²)
2647 (65-2647)	F M	Clear		.177" (4.5mm)	(1219.2mm x 2438.4mm + 6.35/-0)	1.150 lb / ft ² (5.155 kg / m ²)

Standard Machining Services

Machining Type	Reference Page
Cut-to-Size	876
Drill Thru	897



Part Description:

Acrylonitrile butadiene styrene (ABS) haircell panels are a cost-effective option that has one smooth side and one textured side which hides scratches and marks. It provides impact resistance and is stable up to 180 degrees Fahrenheit. ABS haircell is easily machined with simple hand tools and resists cracking, chipping or breaking when cut or drilled. It is commonly used in furniture, workstations, displays and partitions.



Black

Part No. (Metric)	Series	Color	Material	Thickness	Stock Sheet Size	Weight
2613-S (65-2613-S)	F M	Black	ABS	.236" (6.mm)	48" + .250/-0 x 96" +.500/-0 (1219.2mm + 6.35/-0 x 2438.4mm + 12.7/-0)	1.700 lb / ft ² (5.689 kg / m ²)
2613-T (65-2613-T)	F M	Black		.236" (6.mm)		1.700 lb / ft ² (5.689 kg / m ²)
2614-S (65-2614-S)	F M	Black		.177" (4.5mm)		1.000 lb / ft ² (4.965 kg / m ²)
2614-T (65-2614-T)	F M	Black		.177" (4.5mm)		1.000 lb / ft ² (4.965 kg / m ²)

See page 450 for important ordering information.

Standard Machining Services

Machining Type	Reference Page
Cut-to-Size	876
Drill Thru	897

Kydex[®] Panels

Part Description:

Kydex[®] panels are impact and chemical resistant with an option for either a smooth finish or a texture on one side which hides scratches and marks. It is stable up to 160 degrees Fahrenheit and is available in black or yellow. Kydex[®] is commonly used in exhibits, displays, signs, and fixtures.



Black

Yellow

Part No. (Metric)	Series	Color	Material	Thickness	Stock Sheet Size	Weight
2660-S (65-2660-S)	F M	Black	Kydex	.187" (4.70mm)	48" x 96" + .375/-0 (1219.2mm x 2438.4mm + 9.50/-0)	1.239 lb / ft ² (6.189 kg / m ²)
2660-T (65-2660-T)	F M	Black		.187" (4.70mm)		1.239 lb / ft ² (6.189 kg / m ²)
2661-S (65-2661-S)	F M	Black		.250" (6.30mm)		1.728 lb / ft ² (8.436 kg / m ²)
2661-T (65-2661-T)	F M	Black		.250" (6.30mm)		1.728 lb / ft ² (8.436 kg / m ²)
2662-S (65-2662-S)	F M	Yellow		.187" (4.70mm)		1.224 lb / ft ² (6.103 kg / m ²)
2662-T (65-2662-T)	F M	Yellow		.187" (4.70mm)		1.224 lb / ft ² (6.103 kg / m ²)
2663-S (65-2663-S)	F M	Yellow		.250" (6.30mm)		1.440 lb / ft ² (7.030 kg / m ²)
2663-T (65-2663-T)	F M	Yellow		.250" (6.30mm)		1.440 lb / ft ² (7.030 kg / m ²)

See page 448 for important ordering information.

Standard Machining Services

Machining Type	Reference Page
Cut-to-Size	876
Drill Thru	897



Part Description:

Expanded polyvinyl chloride (PVC) panels are a lightweight, cost-effective option available in six colors. This panel is both chemical and weather resistant while being stable up to 140 degrees Fahrenheit. Expanded PVC panels are commonly used in signs, displays, and exhibits.



Part No. (Metric)	Series	Color	Material	Thickness	Stock Sheet Size	Weight
2615 (65-2615)	F M	White	PVC	.236" (6mm)	48" + .197/-0 x 96" + .394/-0 (1219.2mm + 5.0/-0 x 2438.4mm + 10.0/-0)	.625 lb / ft ² (3.051 kg / m ²)
2616 (65-2616)	F M	White		.118" (3mm)		.438 lb / ft ² (2.136 kg / m ²)
2617 (65-2617)	F M	Black		.236" (6mm)		.625 lb / ft ² (3.051 kg / m ²)
2618 (65-2618)	F M	Black		.118" (3mm)		.438 lb / ft ² (2.136 kg / m ²)
2619 (65-2619)	F M	Red		.236" (6mm)		.625 lb / ft ² (3.051 kg / m ²)
2620 (65-2620)	F M	Red		.118" (3mm)		.438 lb / ft ² (2.136 kg / m ²)
2621 (65-2621)	F M	Blue		.236" (6mm)		.625 lb / ft ² (3.051 kg / m ²)
2622 (65-2622)	F M	Blue		.118" (3mm)		.438 lb / ft ² (2.136 kg / m ²)
2623 (65-2623)	F M	Gray		.236" (6mm)		.625 lb / ft ² (3.051 kg / m ²)
2624 (65-2624)	F M	Gray		.118" (3mm)		.438 lb / ft ² (2.136 kg / m ²)
2631 (65-2631)	F M	Yellow		.236" (6mm)		.625 lb / ft ² (3.051 kg / m ²)
2632 (65-2632)	F M	Yellow		.118" (3mm)		.438 lb / ft ² (2.136 kg / m ²)

Standard Machining Services

Machining Type	Reference Page
Cut-to-Size	876
Drill Thru	897

Alucobest™ Panels

Part Description:

Alucobest™ panels are comprised of an aluminum composite, making it a strong and durable option while being half the weight of aluminum. It provides impact and weather resistance and is stable up to 175 degrees Fahrenheit. This panel is easily machined and resists buckling and warping. Alucobest panels are commonly used in guarding, enclosures and workstations.



Platinum

Part No.	Series	Color	Material	Thickness	Stock Sheet Size	Weight
2650	F	Platinum	Aluminum Composite	.236"	50" x 122" +/- .079	1.490 lb / ft ²
65-2650	M			6mm	1270mm x 3098.8mm + 2.0/-0	7.068 kg / m ²

Standard Machining Services

Machining Type	Reference Page
Cut-to-Size	876
Drill Thru	897



Part Description:

Alumalite™ panels are comprised of aluminum composite and are a light yet durable option. This panel is stable up to 125 degrees Fahrenheit and is weather resistant, making it suitable for indoor and outdoor applications. Alumalite is an aesthetic panel and available in five colors; it is commonly used in furniture, enclosures, signs and displays.



Part No. (Metric)	Series	Color	Material	Thickness	Stock Sheet Size	Weight
2633 (65-2633)	F M	Blue	Alumalite	.236" (6mm)	48" x 96" + .250/-0 (1219.2mm x 2438.4mm + 6.3/-0)	.625 lb / ft ² (1.83 to 3.15kg / m ²)
2634 (65-2634)	F M	Red				
2635 (65-2635)	F M	Silver				
2636 (65-2636)	F M	Yellow				
2637 (65-2637)	F M	Black				

Standard Machining Services

Machining Type	Reference Page
Cut-to-Size	876
Drill Thru	897

Twin Wall Polycarbonate Panels

Part Description:

Twin wall polycarbonate panels are a lightweight, weather resistant option, making it ideal for both indoor and outdoor applications. It provides 90 percent light transmission while the twin wall configuration adds durability. Twin wall polycarbonate is commonly used in greenhouses, enclosures, and partitions.



Part No.	Series	Color	Material	Thickness	Stock Sheet Size	Weight
2640	F	Clear	Polycarbonate	.236"	48" + .157/-0 x 96" + .197/-0	.266 lb / ft ²
65-2640	M			6mm	1219.2mm + 4.0/-0 x 2438.4mm + 5.0/-0	1.293 kg / m ²

See page 448 for important ordering information.

Standard Machining Services

Machining Type	Reference Page
Cut-to-Size	876
Drill Thru	897



Part Description:

High density polyethylene (HDPE) panels are a strong, corrosion resistant option that provides durability and resists warping. All options except the natural HDPE have texture on both sides, which masks scratches and marks. HDPE panels are chemical and impact resistant, available in six color options and easily machined. They are a great solution in a wide range of indoor and outdoor environments and commonly used in workspaces, storage and organization units, and enclosures.



Black

Blue

Gray

White

Red

Natural

Yellow

Part No. (Metric)	Series	Color	Material	Thickness	Stock Sheet Size	Weight
2651 (65-2651)	F M	Black	HDPE	.220 - .236" (6mm)	48" + .250/-0 x 96" + .500/-0 (1219.2mm + 6.3/-0 x 2438.4mm + 12.7/-0)	1.200 lb / ft ² (5.86 kg / m ²)
2652 (65-2652)	F M	Black		.177" (4.5mm)		.900 lb / ft ² (4.46 kg / m ²)
2653 (65-2653)	F M	White		.220 - .236" (6mm)		1.200 lb / ft ² (5.12 kg / m ²)
2654 (65-2654)	F M	White		.177" (4.5mm)		.900 lb / ft ² (4.50 kg / m ²)
2655 (65-2655)	F M	Gray		.220 - .236" (6mm)		1.200 lb / ft ² (5.12 kg / m ²)
2656 (65-2656)	F M	Gray		.177" (4.5mm)		.900 lb / ft ² (4.31 kg / m ²)
2657 (65-2657)	F M	Yellow		.220 - .236" (6mm)		1.200 lb / ft ² (5.24 kg / m ²)
2658 (65-2658)	F M	Yellow		.177" (4.5mm)		.900 lb / ft ² (4.50 kg / m ²)
2666 (65-2666)	F M	Blue		.220 - .236" (6mm)		1.200 lb / ft ² (5.20 kg / m ²)
2667 (65-2667)	F M	Blue		.177" (4.5mm)		.900 lb / ft ² (4.27 kg / m ²)
2668 (65-2668)	F M	Red		.220 - .236" (6mm)		1.200 lb / ft ² (5.17 kg / m ²)
2669 (65-2669)	F M	Red		.177" (4.5mm)		.900 lb / ft ² (4.36 kg / m ²)
2812 (65-2812)	F M	Natural		.375" (9.5mm)		1.824 lb / ft ² (9.17 kg / m ²)
2813 (65-2813)	F M	Natural		.500" (12mm)		2.416 lb / ft ² (11.96 kg / m ²)

Standard Machining Services

Machining Type	Reference Page
Cut-to-Size	876
Drill Thru	897

HDPE Pegboard

Part Description:

High density polyethylene (HDPE) pegboard is a strong, corrosion-resistant panel that slides right into profile T-slots. It offers high durability and doesn't warp, making it a great solution for storage and organization in a wide range of environments. Use it in applications at work, in the garage or hobby room, or incorporate it into existing designs to make tools easily accessible. This pegboard is a great way to save space while increasing productivity.

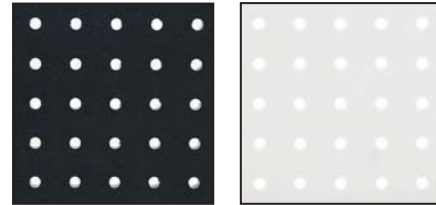

Hole Spacing
1.00" on center

Part No. (Metric)	Series	Color	Material	Thickness	Hole Spacing	Hole Diameter	Stock Sheet Size	Weight
2659 (65-2659)	F M	Black	HDPE	.25" (6mm)	1.00" on center	9/32	48" + .197/-0 x 96" + .394/-0 (1219.2mm + 5.0/-0 x 2438.4mm + 10.0/-0)	1.450 lb / ft ² (7.080 kg / m ²)
2664 (65-2664)	F M	White						

NEW

Standard Machining Services

Machining Type	Reference Page
Cut-to-Size	876



Part Description:

Phenolic Resin panels provide a decorative, durable surface with exceptional impact and scratch resistance. It is a versatile option that can be easily combined with other building materials. Phenolic Resin panels resist moisture and dirt accumulation, making it easy to clean. It is commonly used for interior applications such as work surfaces and table or desk tops in offices and laboratories.



2808 / 65-2808



2814 / 65-2814



2815 / 65-2815

Part No. (Metric)	Series	Color	Material	Finish	Thickness	Stock Sheet Size	Weight
2808 (65-2808)	F M	Black	Phenolic Resin	Black Matte Marble	.750" (19mm)	48" +/- .125" x 96" +/- .156" (1219.2mm +/- 3.175mm x 2438.4 +/- 3.962)	5.600 lb / ft ² (27.340 kg / m ²)
2814 (65-2814)*	F M			Light Matte Woodgrain	.472" (12mm)	51" +/- .125" x 120" +/- .156"	3.647 lb / ft ² (17.806 kg / m ²)
2815 (65-2815)*	F M			Dark Matte Woodgrain	.472" (12mm)	(1295.4mm +/- 3.175mm x 3048.0 +/- 3.962)	3.647 lb / ft ² (17.806 kg / m ²)

*See page 448 for important ordering information.

Standard Machining Services

Machining Type	Reference Page
Cut-to-Size	876

Solid Aluminum Plate

Part Description:

Solid aluminum plate is made of 6061-T6 aluminum alloy and comes standard in an unanodized mill finish. It is a strong, durable option and can be easily machined and anodized. It is available in six thicknesses ranging from .060" (1.524mm) to .500" (12.700mm). Solid aluminum plate is commonly used in structural framing, base plates and industrial tabletops.



Part No. (Metric)	Series	Material	Alloy	Thickness	Stock Sheet Size	Weight
2452 (65-2452)	F M	Aluminum	6061-T6	.060" (1.524mm)	48" +/- .125 x 144" +/- .156 (1219.2mm + 3.2/-0 x 3657.6mm + 4.0/-0)	.889 lb / ft ² (4.336 kg / m ²)
2453 (65-2453)	F M			.125" (3.175mm)		1.764 lb / ft ² (8.672 kg / m ²)
2454 (65-2454)	F M			.187" (4.750mm)		2.680 lb / ft ² (13.008 kg / m ²)
2455 (65-2455)	F M			.250" (6.350mm)		3.700 lb / ft ² (17.344 kg / m ²)
2456 (65-2456)	F M			.375" (9.525mm)		5.550 lb / ft ² (27.100 kg / m ²)
2457 (65-2457)	F M			.500" (12.700mm)		7.400 lb / ft ² (36.134 kg / m ²)

Standard Machining Services

Machining Type	Reference Page
Cut-to-Size	876



Part Description:

Diamond tread plate is made of 3003-H22 aluminum and is a lightweight, strong material with a raised pattern to improve traction and reduce the risk of sliding or slipping. It is available in thicknesses ranging from .125" (3.175mm) to .250" (6.350mm). The 3003-H22 aluminum provides a shiny surface and is widely used in decorative, cosmetic and architectural applications. Diamond tread plate also lends itself to stairs, ramps, walkways, garages and workshops.



Part No. (Metric)	Series	Color	Material	Finish	Thickness	Stock Sheet Size	Weight
2483 (65-2483)	F M	Bright Aluminum	Aluminum	Polished	.125" (3.175mm)	48" x 96" + .250/-0 (1219.2mm x 2438.4mm + 6.35/-0)	1.88 lb / ft ² (9.179 kg / m ²)
2484 (65-2484)	F M				.187" (4.750mm)		2.78 lb / ft ² (13.573 kg / m ²)
2485 (65-2485)	F M				.250" (6.350mm)		3.66 lb / ft ² (17.869 kg / m ²)

Standard Machining Services

Machining Type	Reference Page
Cut-to-Size	876

Laminated Tabletops

Part Description:

Laminated tabletops have a Wilsonart[®] laminate surface that provides an aesthetic appearance. The core is made of particle board and it is commonly used for indoor applications such as countertops, workstations, desks, and tables.



Part No. (Metric)	Series	Color	Surface Material	Thickness	Stock Sheet Size	Weight
2800 (65-2800)		Gray	Wilsonart [®] laminate D92-60	1.25" (31.75mm)	30" x 48" (762.00mm x 1219.20mm)	4.650 lb (22.680 kg)
2802 (65-2802)					30" x 60" (762.00mm x 1524.00mm)	4.704 lb (28.577 kg)
2804 (65-2804)					30" x 72" (762.00mm x 1828.80mm)	4.667 lb (34.020 kg)
2806 (65-2806)					36" x 72" (914.40mm x 1828.80mm)	5.600 lb (40.824 kg)

Standard Machining Services

Machining Type	Reference Page
Cut-to-Length	876

Part Description:

Expanded metal panels are a strong and versatile option that are impact resistant and available in a black or yellow powder coat or galvanized carbon steel finish. Expanded metal has diamond-shape openings that provide visibility and ventilation. It is easy to machine and commonly used in heavy-duty guarding applications.



Part No. (Metric)	Series	Material	Type	Thickness	Diamond Dimensions	Stock Sheet Size	Weight
2480 (65-2480)	F M	Carbon Steel	Flattened	.135" (3.43mm)	2" x .9" (50.4mm x 22.8mm)	48" x 96" + .250/-0 (1219.2mm x 2438.4mm + 6.35/-0)	1.422 lb / ft ² (6.940 kg / m ²)
2481 (65-2481)	F M	Powder Coated Black		.140" (3.43mm)			1.408 lb / ft ² (6.870 kg / m ²)
2482 (65-2482)	F M	Powder Coated Yellow		.140" (3.43mm)			1.376 lb / ft ² (6.720 kg / m ²)

See page 448 for important ordering information.

Standard Machining Services

Machining Type	Reference Page
Shear-to-Size	876

Wire Mesh Panels

Part Description:

Wire mesh panels are a cost-effective option that is lightweight yet impact resistant. Wire mesh has square-shaped openings that provide visibility and ventilation. It is available in a range of gauges, thicknesses, and colors and commonly used in guarding applications and enclosures.

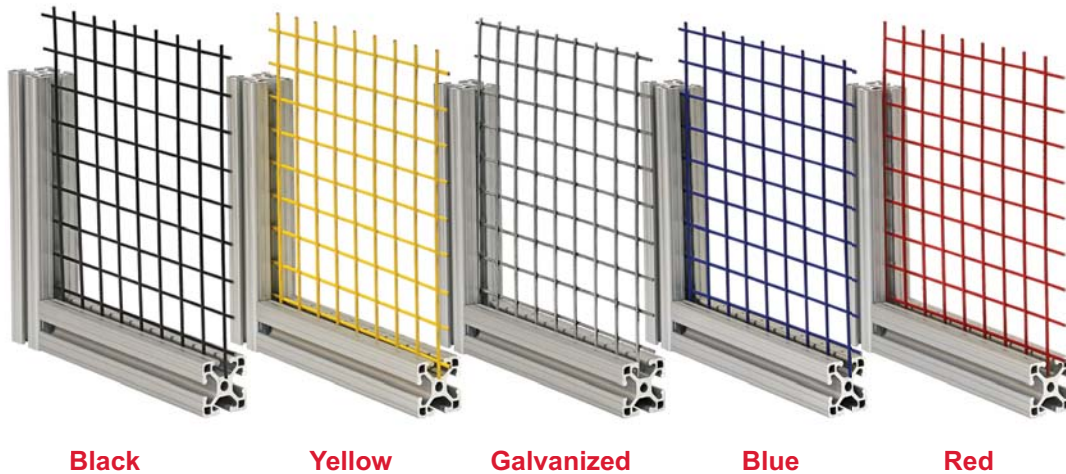

Black

Yellow

Galvanized

Blue

Red

Part No. (Metric)	Series	Material	Gauge	Thickness	Square Dimensions	Stock Sheet Size	Weight
2470 (65-2470)	F M	Galvanized Steel	12	.200" (5.10mm)	1" x 1" (25.40mm x 25.40mm)	48" x 96" +/- .50" (1219.2mm x 2438.4mm)	.618 lb / ft ² (3.017 kg / m ²)
2460 (65-2460)	F M	Galvanized Steel	16	.137" (3.50mm)	.50" x .50" (12.70mm x 12.70mm)		.510 lb / ft ² (2.490 kg / m ²)
2468 (65-2468)	F M	Powder Coated Blue	12	.200" (5.10mm)	1" x 1" (25.40mm x 25.40mm)		1.010 lb / ft ² (4.931 kg / m ²)
2463 (65-2463)	F M	Powder Coated Blue	16	.137" (3.50mm)	.50" x .50" (12.70mm x 12.70mm)		.580 lb / ft ² (2.832 kg / m ²)
2467 (65-2467)	F M	Powder Coated Red	12	.200" (5.10mm)	1" x 1" (25.40mm x 25.40mm)		1.010 lb / ft ² (4.931 kg / m ²)
2462 (65-2462)	F M	Powder Coated Red	16	.137" (3.50mm)	.50" x .50" (12.70mm x 12.70mm)		.580 lb / ft ² (2.832 kg / m ²)
2471 (65-2471)	F M	Powder Coated Yellow	12	.200" (5.10mm)	1" x 1" (25.40mm x 25.40mm)		1.010 lb / ft ² (4.931 kg / m ²)
2461 (65-2461)	F M	Powder Coated Yellow	16	.137" (3.50mm)	.50" x .50" (12.70mm x 12.70mm)		.580 lb / ft ² (2.832 kg / m ²)
2479 (65-2479)	F M	Powder Coated Black	12	.200" (5.10mm)	1" x 1" (25.40mm x 25.40mm)		1.010 lb / ft ² (4.931 kg / m ²)
2464 (65-2464)	F M	Powder Coated Black	16	.137" (3.50mm)	.50" x .50" (12.70mm x 12.70mm)		.580 lb / ft ² (2.832 kg / m ²)

Standard Machining Services

Machining Type	Reference Page
Shear-to-Size	876

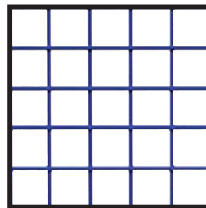

12 Gauge

1" x 1" (25.40mm x 25.40mm)

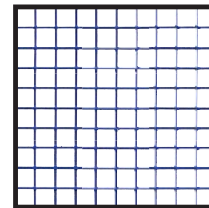

16 Gauge

.50" x .50" (12.70mm x 12.70mm)

Part Description:

Thermoplastic coated wire mesh panels are a cost-effective option that is lightweight yet strong. It has square-shaped openings that provide visibility and ventilation. It has a thermoplastic coat that creates a clean look and helps prevent cuts and other injuries. This panel is available in a range of gauges, thicknesses, and colors and commonly used in guarding applications and enclosures.

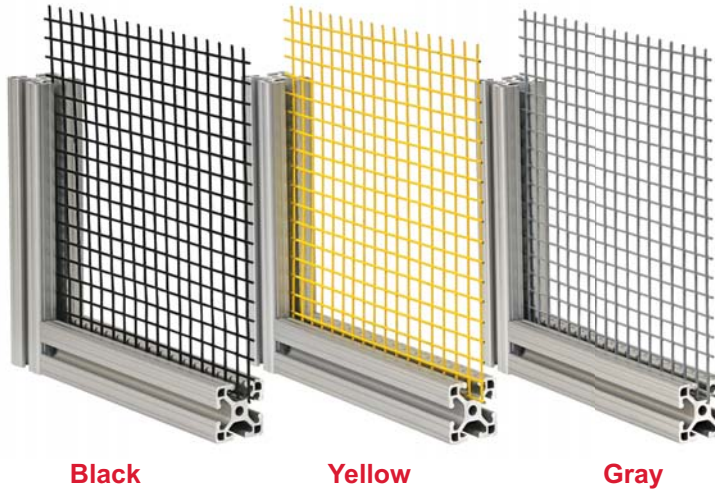

Part No. (Metric)	Series	Material	Gauge	Thickness	Square Dimensions	Stock Sheet Size	Weight
2472 (65-2472)	F M	Thermoplastic Black	12	.210" (5.30mm)	1" x 1" (25.40mm x 25.40mm)	48" x 96" +/- .50" (1219.2mm x 2438.4mm)	.663 lb / ft ² (3.237 kg / m ²)
2474 (65-2474)	F M	Thermoplastic Black	16	.140" (3.55mm)	.50" x .50" (12.70mm x 12.70mm)		.650 lb / ft ² (3.173 kg / m ²)
2478 (65-2478)	F M	Thermoplastic Black	12	.210" (5.30mm)	2" x 2" (50.80mm x 50.80mm)		.663 lb / ft ² (3.237 kg / m ²)
2473 (65-2473)	F M	Thermoplastic Yellow	12	.210" (5.30mm)	1" x 1" (25.40mm x 25.40mm)		.663 lb / ft ² (3.237 kg / m ²)
2475 (65-2475)	F M	Thermoplastic Yellow	16	.140" (3.55mm)	.50" x .50" (12.70mm x 12.70mm)		.650 lb / ft ² (3.173 kg / m ²)
2477 (65-2477)	F M	Thermoplastic Gray	12	.210" (5.30mm)	1" x 1" (25.40mm x 25.40mm)		.663 lb / ft ² (3.237 kg / m ²)
2476 (65-2476)	F M	Thermoplastic Gray	16	.140" (3.55mm)	.50" x .50" (12.70mm x 12.70mm)		.650 lb / ft ² (3.173 kg / m ²)

Standard Machining Services

Machining Type	Reference Page
Shear-to-Size	876

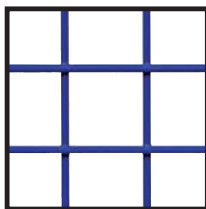

12 Gauge
2" x 2" (50.80mm x 50.80mm)

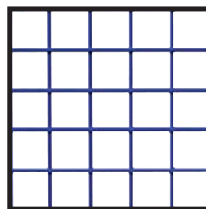

12 Gauge
1" x 1" (25.40mm x 25.40mm)

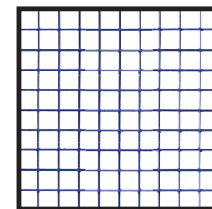

16 Gauge
.50" x .50" (12.70mm x 12.70mm)

Detent Hinge Stopper

Part Description:

The detent hinge stopper is typically used with a detent hinge to prevent over-rotation when a door panel is in a closed position.

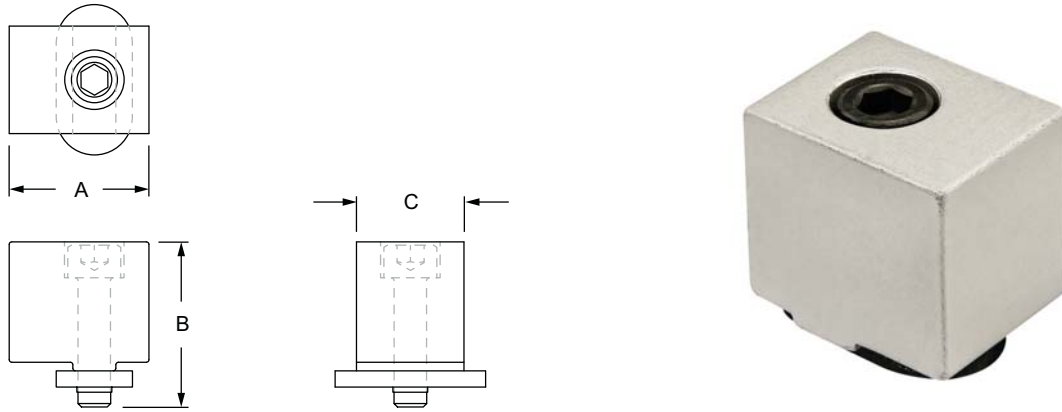

Part No.	Series	Material	Alloy*	Finish	A	B	C	Weight
2054	10 15	Aluminum	6105-T5	Clear Anodize	.812"	.960"	.625"	.047 lb
2054-Black	10 15			Black Anodize	.812"	.960"	.625"	.047 lb
65-2054	25 40			Clear Anodize	20.32mm	25.59mm	15.88mm	.0213 kg
65-2054-Black	25 40			Black Anodize	20.32mm	25.59mm	15.88mm	.0213 kg

* Or comparable

Included Hardware (Mount to T-slot)

Part No.	Series	Qty.	Bolt
3056	10 15	1	10-32 x 3/4" SHCS
3276	10 15	1	Slide-in Economy T-Nut
13-5520	25 40	1	M5 x 4/5" SHCS
25-1951	25 40	1	Slide-in Economy T-Nut

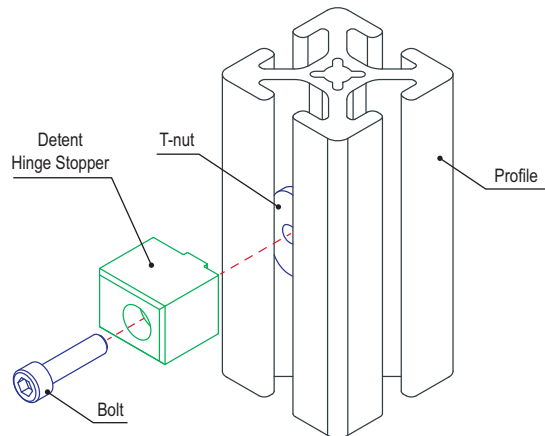



Part Description:

The standard panel mount block can be used to mount a panel flush with a profile edge or on the profile surface. There is a slot tab on the block that helps align the mount in the T-slot. The standard panel mount block is easy to use and simplifies the process of adding or removing plastic panels. The hardware to mount the block to the T-slot is included while the hardware to mount the panel to the block should be based on the panel type and thickness.

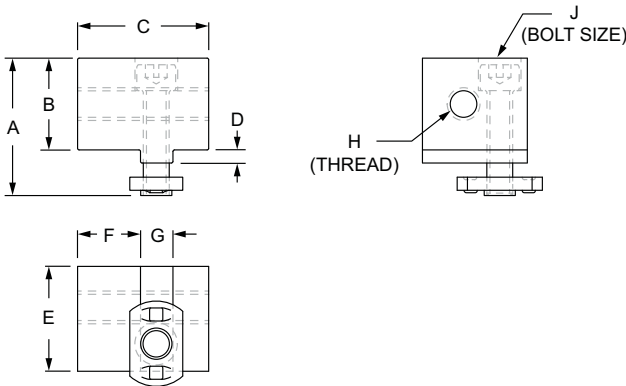

Part No.	Series	Material	Alloy*	Finish	A	B	C	D	E	F	G	H	J	Weight
2910	10	Aluminum	6105-T5	Clear Anodize	.960"	.700"	.812"	.050"	.750"	.380"	.240"	1/4-20	10-32 SHCS	.048 lb
2910-Black	10			Black Anodize	.960"	.700"	.812"	.050"	.750"	.380"	.240"	1/4-20	10-32 SHCS	.048 lb
2900	15			Clear Anodize	1.310"	.875"	1.250"	.125"	1.000"	.600"	.309"	5/16-18	1/4-20 SHCS	.121 lb
2900-Black	15			Black Anodize	1.310"	.875"	1.250"	.125"	1.000"	.600"	.309"	5/16-18	1/4-20 SHCS	.121 lb

* Or comparable

Required Machining Services

Machining Type	Machined	Reference Page
Panel Mount Block Milling	Mounting Panel	893

Included Hardware (Mount to T-Slot)

Part No.	Series	Qty.	Description
3685*	10	1	SS 10-32 x 3/4" SHCS
3676*		1	SS Slide-in Economy T-Nut
3671*	15	1	SS 1/4-20 x 1.0" SHCS
3686*		1	SS Slide-in Economy T-Nut

*Stainless steel (SS) hardware included.

Suggested Hardware (Mount to Panel)

Part No.	Series	Qty.	Bolt
3063	10	1	1/4-20 x 5/8" BHSCS
3065		1	1/4-20 x 3/4" BHSCS
3114	15	1	5/16-18 x 3/4" BHSCS
3117		1	5/16-18 x 7/8" BHSCS

- 3063 - mounts 1/4" panels to the surface of 10 Series profiles.
- 3065 - mounts 1/2" panels to the surface of 10 Series profiles.
- 3114 - mounts 1/4" panels to the surface of 15 Series profiles.
- 3117 - mounts 1/2" panels to the surface of 15 Series profiles.

Panel Covers Profile Surface

Panel Flush with Profile Edge

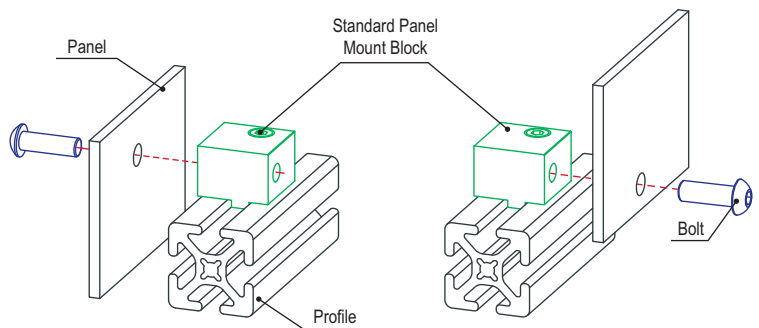

Heavy Panel Mount Block

Part Description:

The heavy panel mount block can be used to mount a panel flush with a profile edge or on the profile surface. There is a slot tab on the block that acts to align the mount in the T-slot. The heavy panel mount block increases stability of the mounted panel while also reducing vibration. It is easy to use and simplifies the process of adding or removing plastic panels. The hardware to mount the block to the T-slot is included while the hardware to mount the panel to the block should be based on the panel type and thickness.

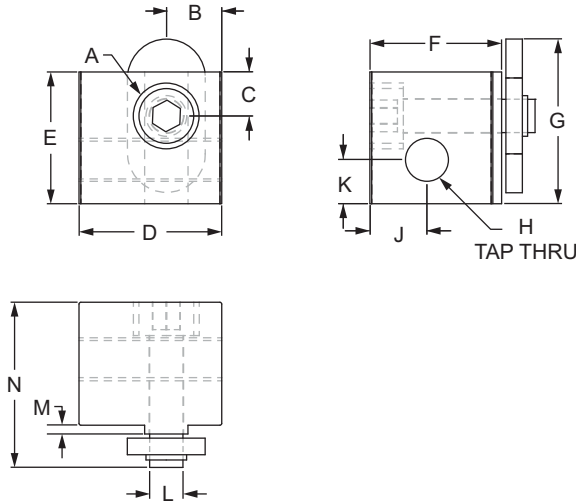

Part No.	Series	A	B	C	D	E	F	G	H	J	K	L	M	N	Weight
2427	10	.375" c-bore .190" deep with .196" thru hole	.316"	.250"	.812"	.750"	.750"	.938"	1/4-20	.325"	.250"	.247"	.050"	.940"	.051 lb
2427-Black	10	.375" c-bore .190" deep with .196" thru hole	.316"	.250"	.812"	.750"	.750"	.938"	1/4-20	.325"	.250"	.247"	.050"	.940"	.051 lb
2425	15	.438" c-bore .250" deep with .257" thru hole	.495"	.263"	1.250"	1.000"	1.000"	1.393"	5/16-18	.443"	.390"	.310"	.125"	1.250"	.121 lb
2425-Black	15	.438" c-bore .250" deep with .257" thru hole	.495"	.263"	1.250"	1.000"	1.000"	1.393"	5/16-18	.443"	.390"	.310"	.125"	1.250"	.121 lb
25-2427	25	9.75mm c-bore 5.60mm deep with 5.60mm thru hole	7.85mm	12.70mm	20.30mm	19.00mm	20.30mm	19.00mm	M6 x 1.0	9.00mm	6.50mm	6.30mm	1.30mm	25.60mm	.0231 kg
25-2427-Black	25	9.75mm c-bore 5.60mm deep with 5.60mm thru hole	7.85mm	12.70mm	20.30mm	19.00mm	20.30mm	19.00mm	M6 x 1.0	9.00mm	6.50mm	6.30mm	1.30mm	25.60mm	.0231 kg
40-2425	40	11.25mm c-bore 6.10mm deep with 6.30mm thru hole	14.15mm	7.13mm	34.30mm	26.00mm	26.30mm	33.16mm	M8 x 1.25	11.60mm	10.00mm	7.87mm	3.10mm	31.16mm	.0644 kg
40-2425-Black	40	11.25mm c-bore 6.10mm deep with 6.30mm thru hole	14.15mm	7.13mm	34.30mm	26.00mm	26.30mm	33.16mm	M8 x 1.25	11.60mm	10.00mm	7.87mm	3.10mm	31.16mm	.0644 kg

- 2427 - mounts 3/16" panels flush with 10 Series profiles.
- 2425 - mounts 1/4" panels flush with 15 Series profiles.
- 25-2427 - mounts 4.5mm panels flush with 25 Series profiles.
- 40-2425 - mounts 6mm panels flush with 40 Series profiles.

CONTINUE

Material Specifications

Part No.	Material	Alloy*	Finish
2427	Aluminum	6105-T5	Clear Anodize
2427-Black			Black Anodize
2425			Clear Anodize
2425-Black			Black Anodize
25-2427			Clear Anodize
25-2427-Black			Black Anodize
40-2425			Clear Anodize
40-2425-Black			Black Anodize

* Or comparable

Required Machining Services

Machining Type	Machined	Reference Page
Panel Mount Block Milling	Mounting Panel	893

Included Hardware (Mount to T-Slot)

Series	Part No.	Qty.	Bolt	Part No.	Qty.	T-Nut
10	3056	1	10-32 x 3/4 SHCS	3276	1	Economy
15	3071	1	1/4-20 x 1.0 SHCS	3286	1	Economy
25	13-5520	1	M5 x 20mm SHCS	25-1951	1	Economy
40	13-6525	1	M6 x 25mm SHCS	3836	1	Economy

Suggested Hardware (Mount to Panel)

Part No.	Series	Qty.	Bolt
3063	10	1	1/4-20 x 5/8 BHSCS
3114	15	1	5/16-18 x 3/4 BHSCS
13-6316	25	1	M6 x 16mm BHSCS
13-8316	40	1	M8 x 16mm BHSCS

Panel Covers Profile Surface

Panel Flush with Profile Edge

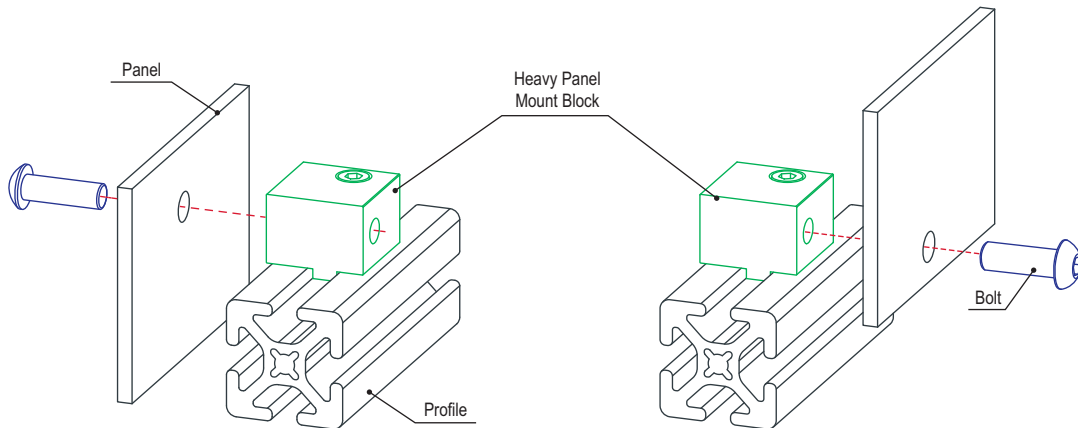

Lite Panel Mount Block

Part Description:

The lite panel mount block is made of nylon and can be used to mount a panel flush with a profile edge or on the profile surface. The lite panel mount block is a cost-effective option that increases stability of the mounted panel while also reducing vibration. The lite panel mount block is easy to use and simplifies the process of adding or removing plastic panels. The suggested bolt assembly to mount the block to the T-slot can be found below. The hardware to mount the panel to the block should be based on the panel type and thickness.

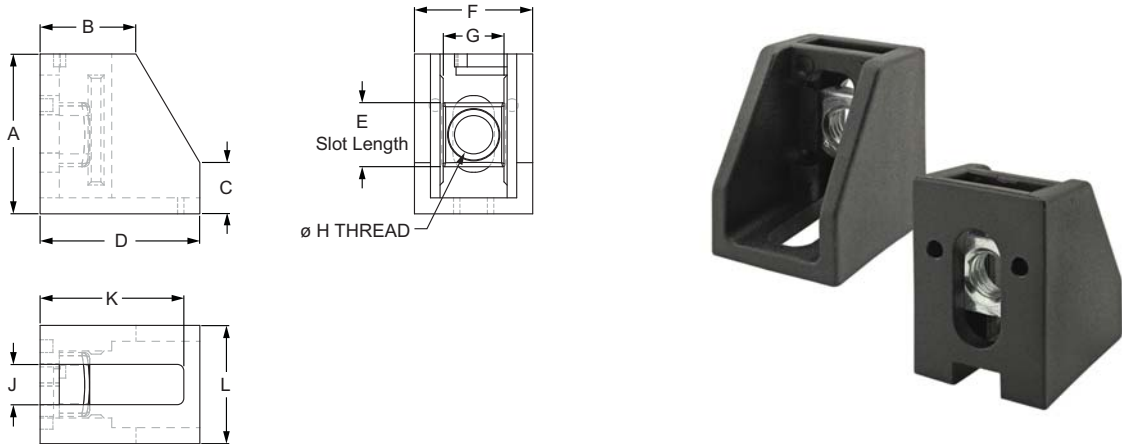

Part No.	Series	A	B	C	D	E	F	G	H	J	K	L	Weight
12050	15 30 40 45	25.00mm	15.00mm	8.00mm	25.00mm	10.00mm	18.50mm	9.50mm	M6 x 1.0	6.30mm	22.50mm	18.50mm	.0037 kg
14192	15 30 40 45	25.00mm	15.00mm	8.00mm	25.00mm	10.00mm	18.50mm	9.50mm	1/4-20	6.30mm	22.50mm	18.50mm	.0086 kg

Material Specifications

Material	Color	Process
Nylon	Black	Injection Molding

Required Machining Services

Machining Type	Machined	Reference Page
Panel Mount Block Milling	Mounting Panel	893

Suggested Hardware (Mount to T-Slot)

Part No.	Series	Qty.	Bolt	T-Nut
3408	15	1	1/4-20 x 1/2 BHSCS	Drop-in
75-3599	30	1	M6 x 10mm BHSCS	Drop-in
75-3600	40	1	M6 x 12mm BHSCS	Drop-in
75-3602	45	1	M6 x 14mm BHSCS	Drop-in

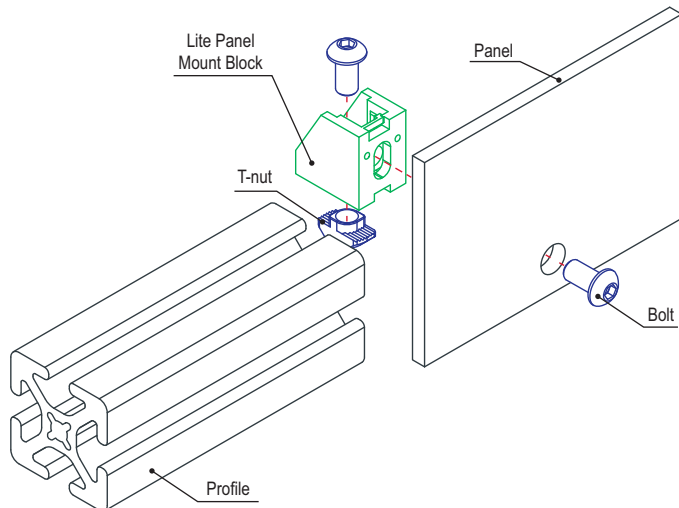

Part Description:

The drop-in lite panel mount block is made of nylon and can be used to mount a panel flush with a profile edge or on the profile surface. It has a molded extension that acts as a T-slot stud and drops into the profile, perfect for instances where profile ends are captivated. The block is a cost-effective option that increases stability of the mounted panel while also reducing vibration. The drop-in lite panel mount block is easy to use and simplifies the process of adding or removing plastic panels.

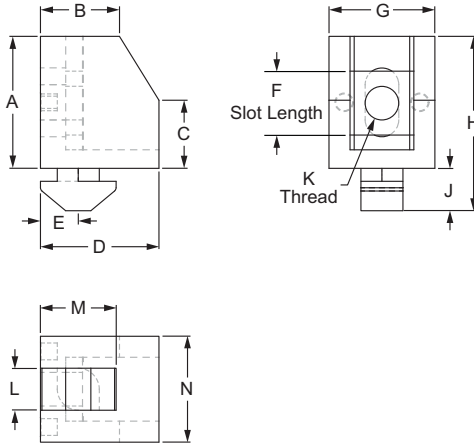

Part No.	Series	A	B	C	D	E	F	G	H	J	K	L	M	N	Weight
14139	15 40	25.00mm	13.00mm	9.00mm	25.00mm	8.50mm	12.50mm	18.50mm	34.00mm	9.00mm	M6 x 1.0	6.00mm	17.00mm	18.50mm	.0100 kg
14186	15 40	25.00mm	13.00mm	9.00mm	25.00mm	8.50mm	12.50mm	18.50mm	34.00mm	9.00mm	1/4-20	6.00mm	17.00mm	18.50mm	.0998 kg
14142	15 40	25.00mm	13.00mm	9.00mm	25.00mm	12.50mm	12.50mm	18.50mm	34.00mm	9.00mm	M6 x 1.0	6.00mm	17.00mm	18.50mm	.0181 kg
14143	15 40	25.00mm	13.00mm	9.00mm	25.00mm	14.50mm	12.50mm	18.50mm	34.00mm	9.00mm	M6 x 1.0	6.00mm	17.00mm	18.50mm	.0100 kg
14167	15 40	25.00mm	13.00mm	9.00mm	25.00mm	12.50mm	12.50mm	18.50mm	34.00mm	9.00mm	1/4-20	6.00mm	17.00mm	18.50mm	.0100 kg
14191	15 40	25.00mm	13.00mm	9.00mm	25.00mm	14.50mm	15.60mm	18.50mm	34.00mm	9.00mm	1/4-20	6.00mm	17.00mm	18.50mm	.0100 kg
14148	20	15.70mm	9.40mm	8.10mm	14.10mm	4.50mm	7.60mm	12.60mm	20.75mm	5.05mm	M4 x 0.6	5.00mm	9.00mm	12.60mm	.0027 kg
14138	30	25.00mm	16.00mm	—	18.50mm	7.00mm	10.50mm	18.50mm	31.20mm	6.20mm	M6 x 1.0	8.00mm	14.00mm	18.50mm	.0086 kg
14185	30	25.00mm	16.00mm	—	18.50mm	7.00mm	10.50mm	18.50mm	31.20mm	6.20mm	1/4-20	8.00mm	14.00mm	18.50mm	.0039 kg
14140	45	25.00mm	13.00mm	9.00mm	25.00mm	9.50mm	12.50mm	18.50mm	35.30mm	10.30mm	M6 x 1.0	9.00mm	15.50mm	18.50mm	.0106 kg
14188	45	25.00mm	13.00mm	9.00mm	25.00mm	9.50mm	12.50mm	18.50mm	35.30mm	10.30mm	1/4-20	9.00mm	15.50mm	18.50mm	.0104 kg
14189	45	25.00mm	13.00mm	9.00mm	25.00mm	14.00mm	12.50mm	18.50mm	35.30mm	10.30mm	M6 x 1.0	9.00mm	15.50mm	18.50mm	.0109 kg
14190	45	25.00mm	13.00mm	9.00mm	25.00mm	14.00mm	12.50mm	18.50mm	35.30mm	10.30mm	1/4-20	9.00mm	15.50mm	18.50mm	.0104 kg

Material Specifications

Material	Color	Process
Nylon	Black	Injection Molding

Required Machining Services

Machining Type	Machined	Reference Page
Panel Mount Block Milling	Mounting Panel	893

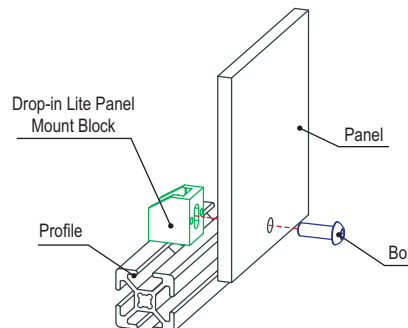

Adjustable Panel Mount Block

Part Description:

The adjustable panel mount block is made of die-cast zinc and can be used to mount a panel flush with a profile edge or the profile surface. It is a strong, heavy-duty option that increases stability of the mounted panel while also reducing vibration. It's easy to use and simplifies the process of adding or removing plastic or aluminum panels. The block provides three options to mount the panel and is slotted to accommodate a variety of panel thicknesses as well as help with aligning the block to the profile. There is an option available with an adjustable anti-rotation clip. The suggested hardware can be found below.

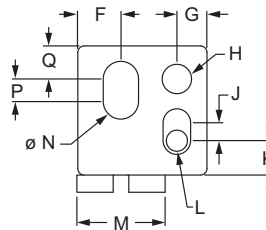
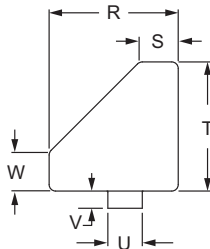
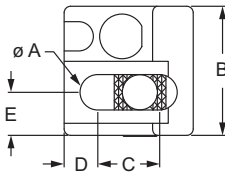

Part No.	Series	A	B	C	D	E	F	G	H	J	K	L
12057	15 40	8.20mm	30.00mm	14.40mm	7.80mm	10.00mm	10.00mm	7.00mm	M8 x 1.25	4.20mm	8.00mm	M6 x 1.0
12058*	15 40	8.20mm	30.00mm	14.40mm	7.80mm	10.00mm	10.00mm	7.00mm	M8 x 1.25	4.20mm	8.00mm	M6 x 1.0
		M	N	P	Q	R	S	T	U	V	W	Weight
12057	15 40	—	8.20mm	5.20mm	7.70mm	30.00mm	9.00mm	30.00mm	—	—	9.00mm	.0653 kg
12058*	15 40	20.50mm	8.20mm	5.20mm	7.70mm	30.00mm	9.00mm	30.00mm	8.00mm	4.00mm	9.00mm	.0694 kg

* This block comes with an adjustable anti-rotation clip.

Material Specifications

Material	Finish	Process
Zinc	Smooth Black	Die Cast

Required Machining Services

Machining Type	Machined	Reference Page
Drill Thru	Mounting Panel	897

Suggested Hardware (Mount to T-Slot)

Part No.	Series	Qty.	Bolt	T-Nut
75-3627	15 40	1	M8 x 18mm SHCS	Slide-in

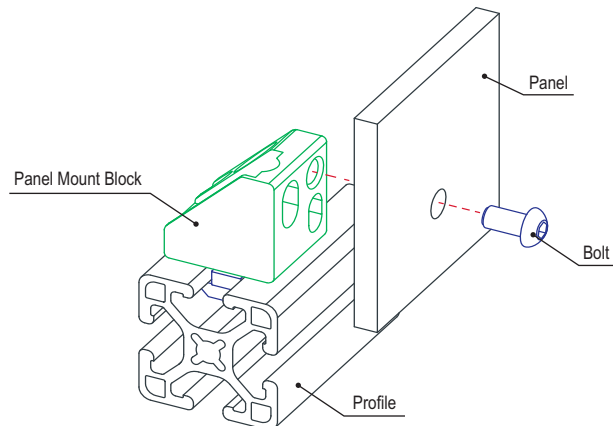

Part Description:

The lite panel mount block spacer works with either the lite or drop-in lite panel mount block to increase its thickness and allow for offset panel mounting. It also reduces vibration and movement.

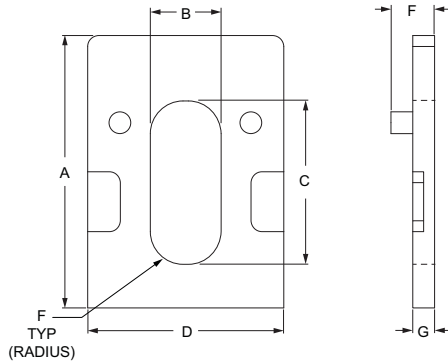

Part No.	Series	Material	Color	Process	A	B	C	D	E	F	G	Weight
12051	15 30 40 45	Nylon	Black	Injection Molding	25.00mm	6.50mm	15.00mm	18.00mm	3.00mm	4.00mm	2.00mm	.0009 kg
12053	15 30 40 45				25.00mm	6.50mm	15.00mm	18.00mm	3.00mm	5.00mm	3.00mm	.0012 kg
12055	15 30 40 45				25.00mm	6.50mm	15.00mm	18.00mm	3.00mm	7.00mm	5.00mm	.0023 kg

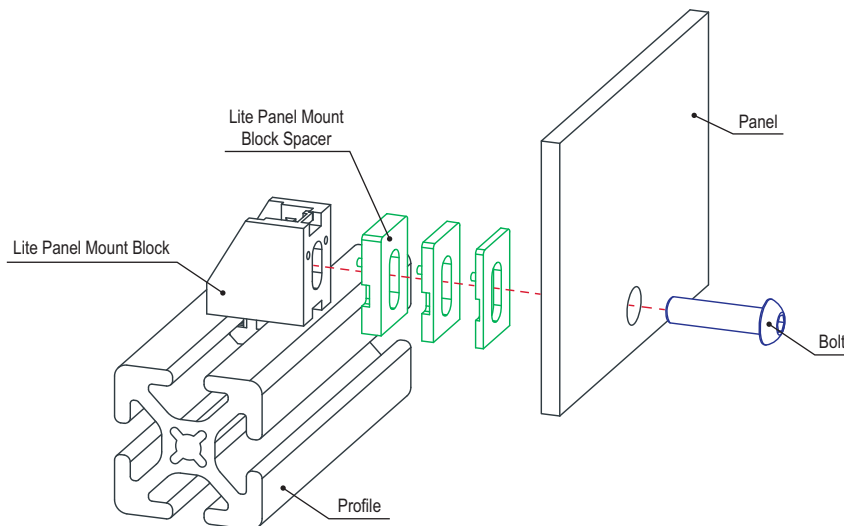

Quick Change Panel Clamp

Part Description:

The quick change panel clamp is made of nylon and consists of a block and clip. It requires no machining or hardware and can be used to mount a panel flush with a profile edge. The quick change panel clamp has a molded extension that acts as a T-slot stud and drops into the profile, perfect for instances where profiles are captivated. The clip secures the panel to the block while the block increases stability of the mounted panel and reduces vibration. The quick change panel clamp clip can be removed with a flat tip screwdriver which simplifies the process of adding or removing plastic panels.

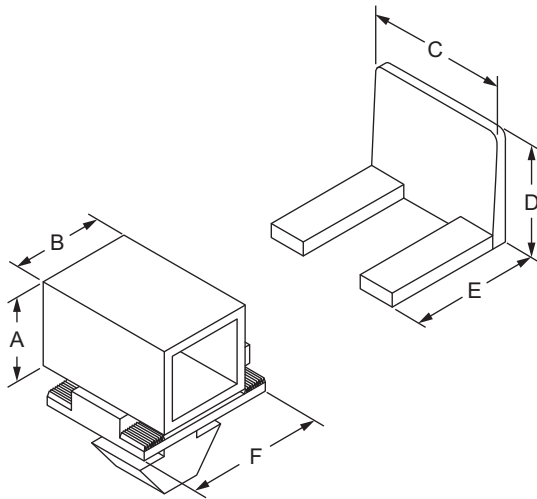

Part No.	Series	Type	Material	Color	A	B	C	D	E	F	Weight
2421	15	Block & Clip	Nylon	Black	.775"	.640"	.980"	.785"	.870"	.920"	.018 lb
2422	15	Block			.775"	.640"	—	—	—	.920"	.014 lb
2423	15	Clip			—	—	.980"	.785"	.870"	—	.004 lb
40-2421	40	Block & Clip			19.70mm	16.30mm	24.90mm	19.90mm	22.10mm	23.30mm	.0064 kg
40-2422	40	Block			19.70mm	16.30mm	—	—	—	23.30mm	.0062 kg
40-2423	40	Clip			—	—	24.90mm	19.90mm	22.10mm	—	.0019 kg

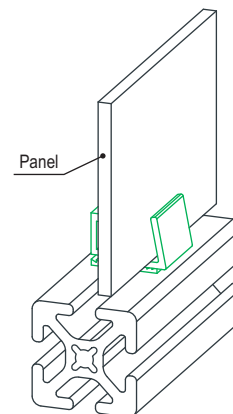
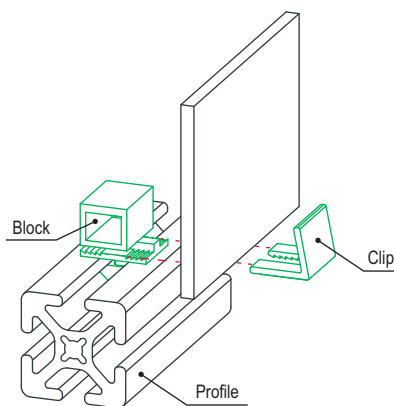

Part Description:

The panel mount bracket is used to surface mount a panel to a profile and has a slotted hole which allows for greater adjustability when mounting the panel. It engages the 2-degree drop-lock feature when the assembly bolts are tightened to the required torque. The panel mount bracket is a fastening method that can be repositioned and reused. The panel requires a through hole (page 897) as well as hardware to mount the panel to the bracket, which should be based on the panel type and thickness. The suggested hardware for mounting the bracket to the T-slot can be found below.

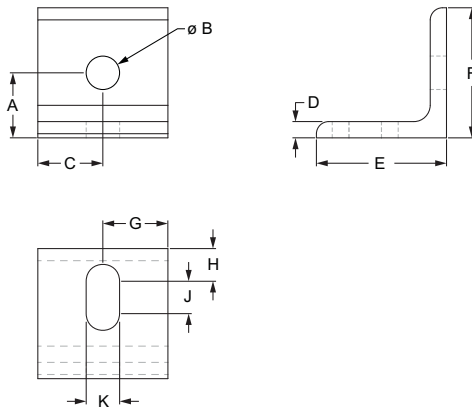

Part No.	Series	Color	A	B	C	D	E	F	G	H	J	K	Weight
2428	10	Clear	.500"	.257"	.500"	.125"	1.000"	1.000"	.500"	.250"	.250"	.257"	.018 lb
2428-Black	10	Black	.500"	.257"	.500"	.125"	1.000"	1.000"	.500"	.250"	.250"	.257"	.018 lb
2430	15	Clear	.500"	.328"	.500"	.125"	1.000"	1.000"	.500"	.281"	.250"	.328"	.019 lb
2430-Black	15	Black	.500"	.328"	.500"	.125"	1.000"	1.000"	.500"	.281"	.250"	.328"	.019 lb
25-2428	25	Clear	12.50mm	6.30mm	12.50mm	3.00mm	25.00mm	25.00mm	12.50mm	6.00mm	6.50mm	6.30mm	.0088 kg
25-2428-Black	25	Black	12.50mm	6.30mm	12.50mm	3.00mm	25.00mm	25.00mm	12.50mm	6.00mm	6.50mm	6.30mm	.0088 kg
40-2430	40	Clear	12.50mm	8.30mm	12.50mm	3.00mm	25.00mm	25.00mm	12.50mm	6.88mm	6.05mm	8.28mm	.0077 kg
40-2430-Black	40	Black	12.50mm	8.30mm	12.50mm	3.00mm	25.00mm	25.00mm	12.50mm	6.88mm	6.05mm	8.28mm	.0077 kg

Material Specifications

Material	Alloy*	Finish
Aluminum	6105-T5	Anodize

* Or comparable

Required Machining Services

Machining Type	Machined	Reference Page
Drill Thru	Mounting Panel	897

Suggested Hardware (Mount to T-Slot)

Part No.	Series	Qty.	Bolt	T-Nut
3386	10	1	1/4-20 x 3/8 FBHSCS	Economy
3319	15	1	5/16-18 x 1/2 FBHSCS	Economy
75-3404	25	1	M6 x 10mm BHSCS	Economy
75-3421	40	1	M8 x 12mm BHSCS	Economy

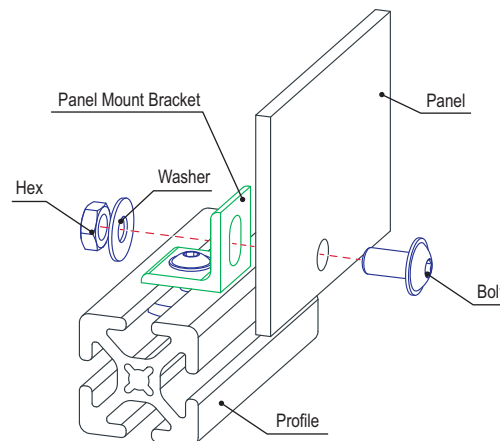

Roll-In Panel Mount Bracket

Part Description:

The roll-in panel mount bracket is used to mount a panel flush with a profile and is designed to allow use even when profiles are captivated. The roll-in panel mount bracket is a fastening method that can be repositioned and reused. To simplify the assembly use either a drill through or a drill through and a tap (page 897). The hardware should be based on machining type and panel thickness.

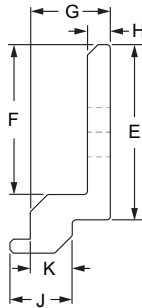
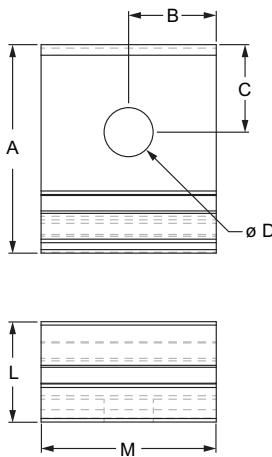

Part No.	Series	Color	A	B	C	D	E	F	G	H	J	K	L	M	Weight
2489	10	Clear	1.190"	.500"	.500"	.281"	1.000"	.855"	.457"	.130"	.356"	.240"	.573"	1.000"	.020 lb
2489-Black	10	Black	1.190"	.500"	.500"	.281"	1.000"	.855"	.457"	.130"	.356"	.240"	.573"	1.000"	.020 lb
2488	15	Clear	1.805"	.750"	.745"	.328"	1.500"	1.305"	.610"	.130"	.476"	.304"	.782"	1.500"	.053 lb
2488-Black	15	Black	1.805"	.750"	.745"	.328"	1.500"	1.305"	.610"	.130"	.476"	.304"	.782"	1.500"	.053 lb
25-2489	25	Clear	30.23mm	12.70mm	12.70mm	7.10mm	25.40mm	21.72mm	11.61mm	3.30mm	9.04mm	6.10mm	14.55mm	25.40mm	.0095 kg
25-2489-Black	25	Black	30.23mm	12.70mm	12.70mm	7.10mm	25.40mm	21.72mm	11.61mm	3.30mm	9.04mm	6.10mm	14.55mm	25.40mm	.0095 kg
40-2488	40	Clear	45.86mm	19.05mm	18.93mm	8.30mm	38.10mm	33.16mm	15.49mm	3.30mm	12.09mm	7.72mm	19.86mm	38.10mm	.0240 kg
40-2488-Black	40	Black	45.86mm	19.05mm	18.93mm	8.30mm	38.10mm	33.16mm	15.49mm	3.30mm	12.09mm	7.72mm	19.86mm	38.10mm	.0240 kg

Material Specifications

Material	Alloy*	Finish
Aluminum	6105-T5	Anodize

* Or comparable

Required Machining Services

Machining Type	Machined	Reference Page
Drill Thru	Mounting Panel	897

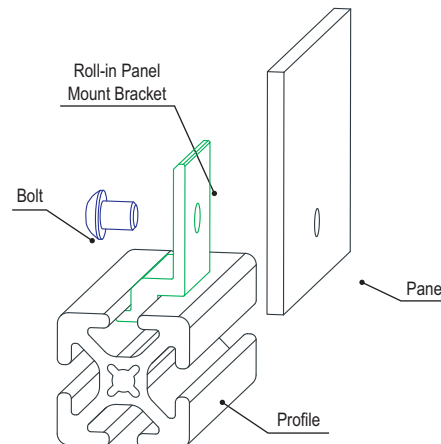

Part Description:

The tabletop fastening kit is typically used to help secure a tabletop to a frame. The kit includes all required hardware to mount the top to the frame; see chart below for additional details.



Part No.	Series	Bracket	Bolt	Nut	Washer	Screw	Weight
2810	15	Slotted Inside Corner Bracket	5/16-18 x 11/16 FBHSCS	5/16-18 Drop-In T-Nut	5/16 Bright Zinc Washer	#14 x 1.25 Phillips Pan Head Sheet Metal Screw	.139 lb
2810-Black			M8 x 16mm BHSCS	M8 Drop-In T-Nut	M8 Bright Zinc Washer		.144 lb
65-2810	40		5/16-18 x 2.0 BHSCS	5/16-18 Flanged Hex Nut	5/16 Bright Zinc Washer	.152 lb	
2811	RT						
2811-Black							

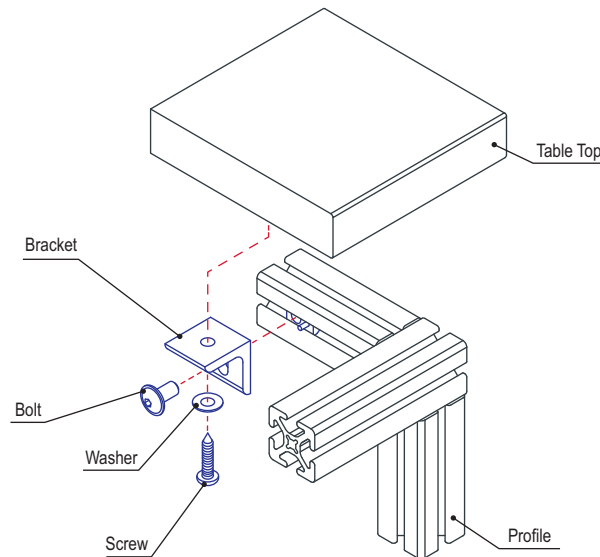

Single Arm Narrow Panel Retainer

Part Description:

The single arm narrow panel retainer is used to mount a panel when it is recessed within the T-slot or on the profile frame. It is a strong fastening option that is simple to use, provides stability, and reduces vibration. The single arm narrow panel retainer is frequently used when mounting one panel to a profile or in instances when larger profile series are used to mount two panels. It requires a drill through machining service on the panel; for information on machining services see page 894.

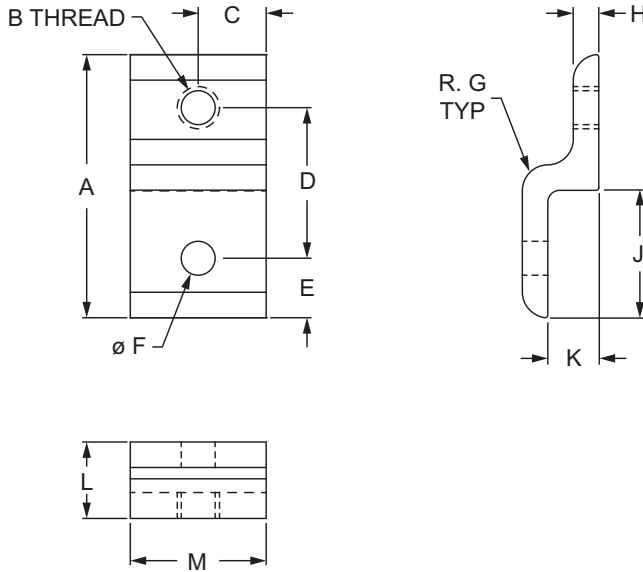

Part No.	Series	A	B	C	D	E	F	G	H	J	K	L	M	Weight
2496	10	1.935"	1/4-20	.500"	1.108"	.437"	.257"	.187"	.188"	.937"	.375"	.543"	1.000"	.039 lb
2496-Black	10	1.935"	1/4-20	.500"	1.108"	.437"	.257"	.187"	.188"	.937"	.375"	.543"	1.000"	.039 lb
2434	15	2.874"	5/16-18	.750"	1.656"	.625"	.328"	.250"	.250"	1.377"	.590"	.840"	1.500"	.117 lb
2434-Black	15	2.874"	5/16-18	.750"	1.656"	.625"	.328"	.250"	.250"	1.377"	.590"	.840"	1.500"	.117 lb
20-2496	20	39.00mm	M5 x 0.8	10.00mm	22.00mm	8.51mm	5.50mm	3.00mm	3.00mm	19.00mm	7.20mm	10.20mm	20.00mm	.0065 kg
20-2496-Black	20	39.00mm	M5 x 0.8	10.00mm	22.00mm	8.51mm	5.50mm	3.00mm	3.00mm	19.00mm	7.20mm	10.20mm	20.00mm	.0065 kg
25-2496	25	48.50mm	M6 x 1.0	12.50mm	27.95mm	10.75mm	6.30mm	4.00mm	4.00mm	23.50mm	9.30mm	13.30mm	25.00mm	.0143 kg
25-2496-Black	25	48.50mm	M6 x 1.0	12.50mm	27.95mm	10.75mm	6.30mm	4.00mm	4.00mm	23.50mm	9.30mm	13.30mm	25.00mm	.0143 kg
30-2434	30	58.00mm	M8 x 1.25	15.00mm	32.50mm	12.50mm	8.30mm	4.00mm	4.00mm	28.00mm	7.20mm	11.20mm	30.00mm	.0194 kg
30-2434-Black	30	58.00mm	M8 x 1.25	15.00mm	32.50mm	12.50mm	8.30mm	4.00mm	4.00mm	28.00mm	7.20mm	11.20mm	30.00mm	.0194 kg
40-2434	40	77.00mm	M8 x 1.25	20.00mm	44.40mm	16.80mm	8.30mm	6.00mm	6.00mm	37.00mm	5.95mm	21.95mm	40.00mm	.0561 kg
40-2434-Black	40	77.00mm	M8 x 1.25	20.00mm	44.40mm	16.80mm	8.30mm	6.00mm	6.00mm	37.00mm	5.95mm	21.95mm	40.00mm	.0561 kg
45-2434	45	87.00mm	M8 x 1.25	22.50mm	48.50mm	19.00mm	8.30mm	6.00mm	6.00mm	42.00mm	17.30mm	23.30mm	45.00mm	.0709 kg
45-2434-Black	45	87.00mm	M8 x 1.25	22.50mm	48.50mm	19.00mm	8.30mm	6.00mm	6.00mm	42.00mm	17.30mm	23.30mm	45.00mm	.0709 kg

CONTINUE

80/20[®] Inc. Single Arm Narrow Panel Retainer (Continued)

Material Specifications

Part No.	Material	Alloy*	Process	Finish
2496	Aluminum	6105-T5	Milled	Clear Anodize
2496-Black				Black Anodize
2434				Clear Anodize
2434-Black				Black Anodize
20-2496				Clear Anodize
20-2496-Black				Black Anodize
25-2496				Clear Anodize
25-2496-Black				Black Anodize
30-2434				Clear Anodize
30-2434-Black				Black Anodize
40-2434				Clear Anodize
40-2434-Black				Black Anodize
45-2434				Clear Anodize
45-2434-Black				Black Anodize

* Or comparable

Required Machining Services

Machining Type	Machined	Reference Page
Panel Retainer Milling	Mounting Panel	894

Suggested Hardware (Mount to T-Slot)

Part No.	Series	Qty.	Bolt	T-Nut
3321	10	1	1/4-20 x 1/2 FBHSCS	Economy
3320	15	1	5/16-18 x 11/16 FBHSCS	Economy
75-3581	20	1	M5 x 8mm BHSCS	Economy
75-3404	25	1	M6 x 10mm BHSCS	Economy
75-3615	30	1	M8 x 12mm BHSCS	Roll-in
75-3422	40	1	M8 x 16mm BHSCS	Economy
75-3619	45	1	M8 x 18mm BHSCS	Drop-in

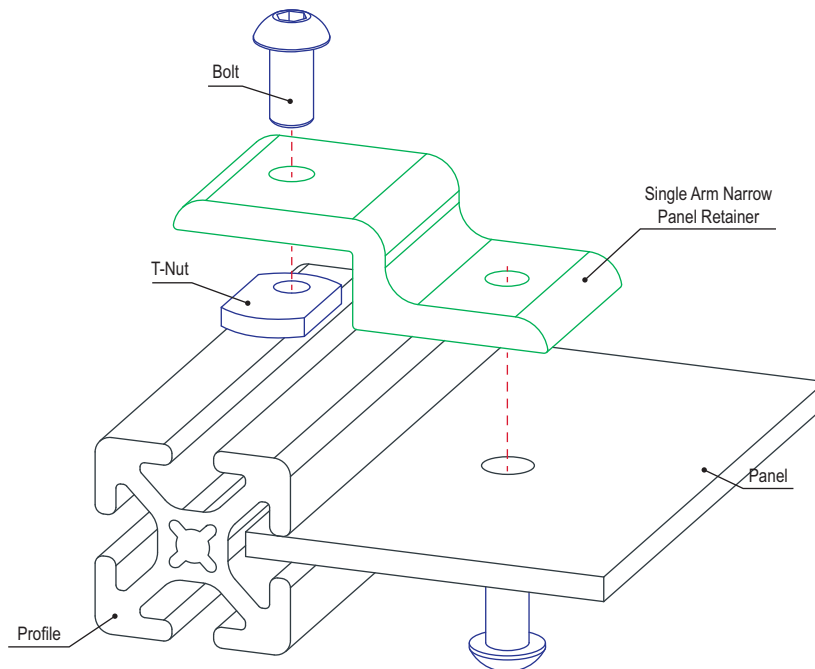

Single Arm Wide Panel Retainer

Part Description:

The single arm wide panel retainer is used to mount a panel when it is recessed within the T-slot or on the profile frame. This is a stronger connection that is also simple to use, provides stability and reduces vibration. The single arm wide panel retainer is frequently used when mounting one panel to a profile or in instances when larger profile series are used to mount two panels. It requires a drill through machining service on the panel; for information on machining services see page 894.

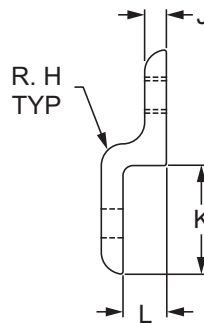
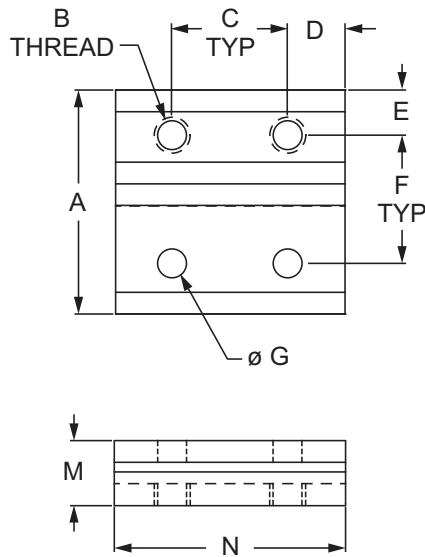

Part No.	Series	A	B	C	D	E	F	G	H	J	K	L	M	N	Weight
2497	10	1.935"	1/4-20	1.000"	.500"	.391"	1.108"	.257"	.187"	.188"	.937"	.375"	.563"	2.000"	.028 lb
2497-Black	10	1.935"	1/4-20	1.000"	.500"	.391"	1.108"	.257"	.187"	.188"	.937"	.375"	.563"	2.000"	.028 lb
2433	15	2.879"	5/16-18	1.500"	.750"	.594"	1.656"	.328"	.250"	.250"	1.379"	.590"	.840"	3.000"	.236 lb
2433-Black	15	2.879"	5/16-18	1.500"	.750"	.594"	1.656"	.328"	.250"	.250"	1.379"	.590"	.840"	3.000"	.236 lb
20-2497	20	39.00mm	M5 x 0.8	20.00mm	10.00mm	8.51mm	22.00mm	5.54mm	3.00mm	3.00mm	19.00mm	7.20mm	10.20mm	40.00mm	.0132 kg
20-2497-Black	20	39.00mm	M5 x 0.8	20.00mm	10.00mm	8.51mm	22.00mm	5.54mm	3.00mm	3.00mm	19.00mm	7.20mm	10.20mm	40.00mm	.0132 kg
25-2497	25	48.50mm	M6 x 1.0	25.00mm	12.50mm	9.80mm	27.95mm	6.30mm	4.00mm	4.00mm	23.50mm	9.30mm	13.30mm	50.00mm	.0129 kg
25-2497-Black	25	48.50mm	M6 x 1.0	25.00mm	12.50mm	9.80mm	27.95mm	6.30mm	4.00mm	4.00mm	23.50mm	9.30mm	13.30mm	50.00mm	.0129 kg
30-2433	30	58.00mm	M8 x 1.25	30.00mm	30.00mm	13.00mm	32.51mm	8.28mm	4.00mm	4.00mm	28.00mm	10.60mm	14.60mm	60.00mm	.0391 kg
30-2433-Black	30	58.00mm	M8 x 1.25	30.00mm	30.00mm	13.00mm	32.51mm	8.28mm	4.00mm	4.00mm	28.00mm	10.60mm	14.60mm	60.00mm	.0391 kg
40-2433	40	77.00mm	M8 x 1.25	40.00mm	20.00mm	15.80mm	44.40mm	8.28mm	6.00mm	6.00mm	37.00mm	16.00mm	22.00mm	80.00mm	.1103 kg
40-2433-Black	40	77.00mm	M8 x 1.25	40.00mm	20.00mm	15.80mm	44.40mm	8.28mm	6.00mm	6.00mm	37.00mm	16.00mm	22.00mm	80.00mm	.1103 kg
45-2433	45	87.00mm	M8 x 1.25	45.00mm	22.50mm	19.50mm	48.50mm	8.28mm	6.00mm	6.00mm	42.00mm	17.30mm	23.30mm	90.00mm	.1441 kg
45-2433-Black	45	87.00mm	M8 x 1.25	45.00mm	22.50mm	19.50mm	48.50mm	8.28mm	6.00mm	6.00mm	42.00mm	17.30mm	23.30mm	90.00mm	.1441 kg

CONTINUE

80/20[®] Inc. Single Arm Wide Panel Retainer (Continued)

Material Specifications

Part No.	Material	Alloy*	Process	Finish
2497	Aluminum	6105-T5	Milled	Clear Anodize
2497-Black				Black Anodize
2433				Clear Anodize
2433-Black				Black Anodize
20-2497				Clear Anodize
20-2497-Black				Black Anodize
25-2497				Clear Anodize
25-2497-Black				Black Anodize
30-2433				Clear Anodize
30-2433-Black				Black Anodize
40-2433				Clear Anodize
40-2433-Black				Black Anodize
45-2433				Clear Anodize
45-2433-Black				Black Anodize

* Or comparable

Required Machining Services

Machining Type	Machined	Reference Page
Panel Retainer Milling	Mounting Panel	894

Suggested Hardware (Mount to T-Slot)

Part No.	Series	Qty.	Bolt	T-Nut
3321	10	2	1/4-20 x 1/2 FBHSCS	Economy
3320	15	2	5/16-18 x 11/16 FBHSCS	Economy
75-3581	20	2	M5 x 8mm BHSCS	Economy
75-3404	25	2	M6 x 10mm BHSCS	Economy
75-3615	30	2	M8 x 12mm BHSCS	Roll-in
75-3422	40	2	M8 x 16mm BHSCS	Economy
75-3619	45	2	M8 x 18mm BHSCS	Drop-in

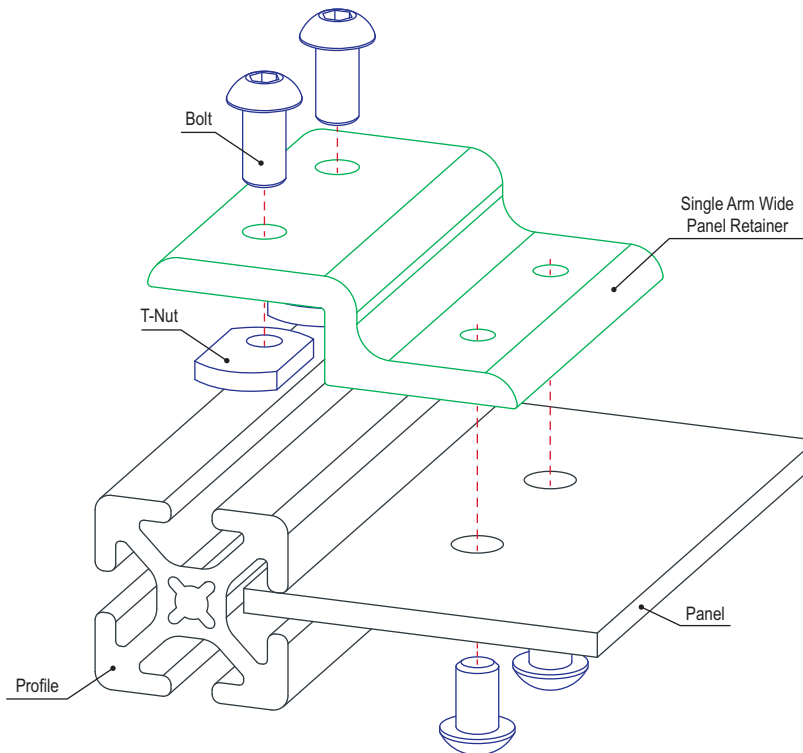

Double Arm Narrow Panel Retainer

Part Description:

The double arm narrow panel retainer is used to mount a panel when it is recessed within the T-slot or on the profile frame. It is a strong fastening option that is simple to use, provides stability and reduces vibration. The double arm narrow panel retainer is perfect in instances when a profile is connecting two adjacent panels. It requires a drill through machining service on the panel; for information on machining services see page 894.

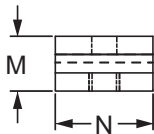
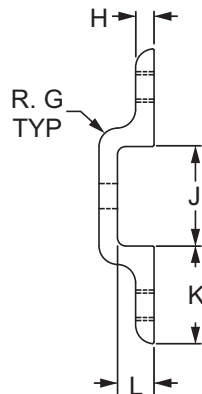
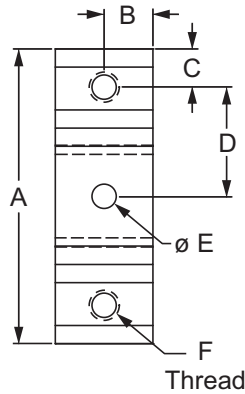

Part No.	Series	A	B	C	D	E	F	G	H	J	K	L	M	N	Weight
2512	10	3.021"	.500"	.392"	1.119"	.257"	1/4-20	.188"	.188"	1.021"	1.000"	.375"	.563"	1.000"	.064 lb
2512-Black	10	3.021"	.500"	.392"	1.119"	.257"	1/4-20	.188"	.188"	1.021"	1.000"	.375"	.563"	1.000"	.064 lb
2515	15	4.523"	.750"	.594"	1.668"	.328"	5/16-18	.250"	.250"	1.523"	1.500"	.590"	.840"	1.500"	.199 lb
2515-Black	15	4.523"	.750"	.594"	1.668"	.328"	5/16-18	.250"	.250"	1.523"	1.500"	.590"	.840"	1.500"	.199 lb
25-2512	25	75.49mm	12.50mm	9.80mm	27.94mm	6.30mm	M6 x 1.0	4.00mm	4.00mm	25.50mm	25.00mm	9.30mm	13.28mm	25.00mm	.0105 kg
25-2512-Black	25	75.49mm	12.50mm	9.80mm	27.94mm	6.30mm	M6 x 1.0	4.00mm	4.00mm	25.50mm	25.00mm	9.30mm	13.28mm	25.00mm	.0105 kg
40-2515	40	120.60mm	20.00mm	15.80mm	44.50mm	8.28mm	M8 x 1.25	6.00mm	6.00mm	40.59mm	40.00mm	16.00mm	22.00mm	40.00mm	.0952 kg
40-2515-Black	40	120.60mm	20.00mm	15.80mm	44.50mm	8.28mm	M8 x 1.25	6.00mm	6.00mm	40.59mm	40.00mm	16.00mm	22.00mm	40.00mm	.0952 kg

CONTINUE

Material Specifications

Part No.	Material	Alloy*	Process	Finish
2512	Aluminum	6105-T5	Milled	Clear Anodize
2512-Black				Black Anodize
2515				Clear Anodize
2515-Black				Black Anodize
25-2512				Clear Anodize
25-2512-Black				Black Anodize
40-2515				Clear Anodize
40-2515-Black				Black Anodize

* Or comparable

Required Machining Services

Machining Type	Machined	Reference Page
Panel Retainer Milling	Mounting Panel	894

Suggested Hardware (Mount to T-Slot)

Part No.	Series	Qty.	Bolt	T-Nut
3321	10	1	1/4-20 x 1/2 FBHSCS	Economy
3320	15	1	5/16-18 x 11/16 FBHSCS	Economy
75-3404	25	1	M6 x 10mm BHSCS	Economy
75-3422	40	1	M8 x 16mm BHSCS	Economy

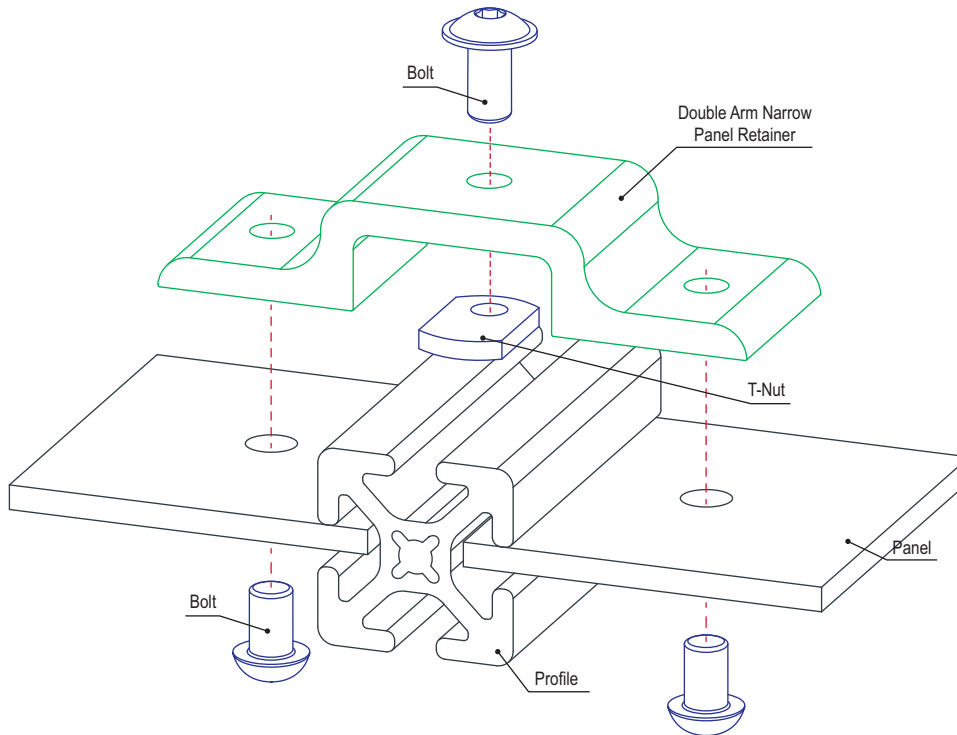

Double Arm Wide Panel Retainer

Part Description:

The double arm wide panel retainer is used to mount a panel when it is recessed within the T-slot or on the profile frame. The wide arm makes this a stronger connection and also provides stability and reduces vibration. The double arm wide panel retainer is perfect in instances when a profile is connecting two adjacent panels. It requires a drill through machining service on the panel; for information on machining services see page 894.

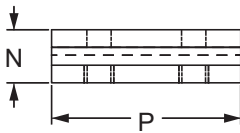
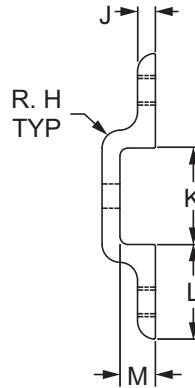
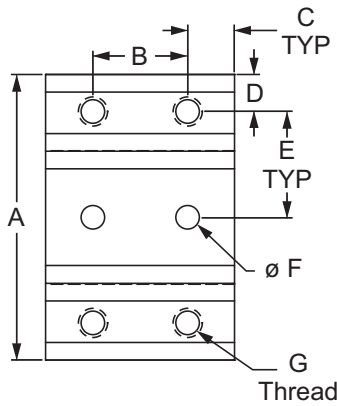

Part No.	Series	A	B	C	D	E	F	G	H	J	K	L	M	N	P	Weight
2513	10	2.000"	1.000"	.500"	.392"	1.119"	.257"	1/4-20	.188"	.188"	1.021"	1.000"	.375"	.563"	2.000"	.127 lb
2513-Black	10	2.000"	1.000"	.500"	.392"	1.119"	.257"	1/4-20	.188"	.188"	1.021"	1.000"	.375"	.563"	2.000"	.127 lb
2516	15	4.523"	1.500"	.750"	.594"	1.668"	.328"	5/16-18	.250"	.250"	1.523"	1.500"	.590"	.840"	3.000"	.396 lb
2516-Black	15	4.523"	1.500"	.750"	.594"	1.668"	.328"	5/16-18	.250"	.250"	1.523"	1.500"	.590"	.840"	3.000"	.396 lb
25-2513	25	75.49mm	25.00mm	12.50mm	9.80mm	27.94mm	6.30mm	M6 x 1.0	4.00mm	4.00mm	25.50mm	25.00mm	9.30mm	13.28mm	50.00mm	.0210 kg
25-2513-Black	25	75.49mm	25.00mm	12.50mm	9.80mm	27.94mm	6.30mm	M6 x 1.0	4.00mm	4.00mm	25.50mm	25.00mm	9.30mm	13.28mm	50.00mm	.0210 kg
40-2516	40	120.60mm	40.00mm	20.00mm	15.80mm	44.50mm	8.28mm	M8 x 1.25	6.00mm	6.00mm	40.59mm	40.00mm	16.00mm	22.00mm	80.00mm	.1875 kg
40-2516-Black	40	120.60mm	40.00mm	20.00mm	15.80mm	44.50mm	8.28mm	M8 x 1.25	6.00mm	6.00mm	40.59mm	40.00mm	16.00mm	22.00mm	80.00mm	.1875 kg

CONTINUE



Double Arm Wide Panel Retainer (Continued)

Material Specifications

Part No.	Material	Alloy*	Process	Finish
2513	Aluminum	6105-T5	Milled	Clear Anodize
2513-Black				Black Anodize
2516				Clear Anodize
2516-Black				Black Anodize
25-2513				Clear Anodize
25-2513-Black				Black Anodize
40-2516				Clear Anodize
40-2516-Black				Black Anodize

* Or comparable

Required Machining Services

Machining Type	Machined	Reference Page
Panel Retainer Milling	Mounting Panel	894

Suggested Hardware (Mount to T-Slot)

Part No.	Series	Qty.	Bolt	T-Nut
3321	10	2	1/4-20 x 1/2 FBHSCS	Economy
3320	15	2	5/16-18 x 11/16 FBHSCS	Economy
75-3404	25	2	M6 x 10mm BHSCS	Economy
75-3422	40	2	M8 x 16mm BHSCS	Economy

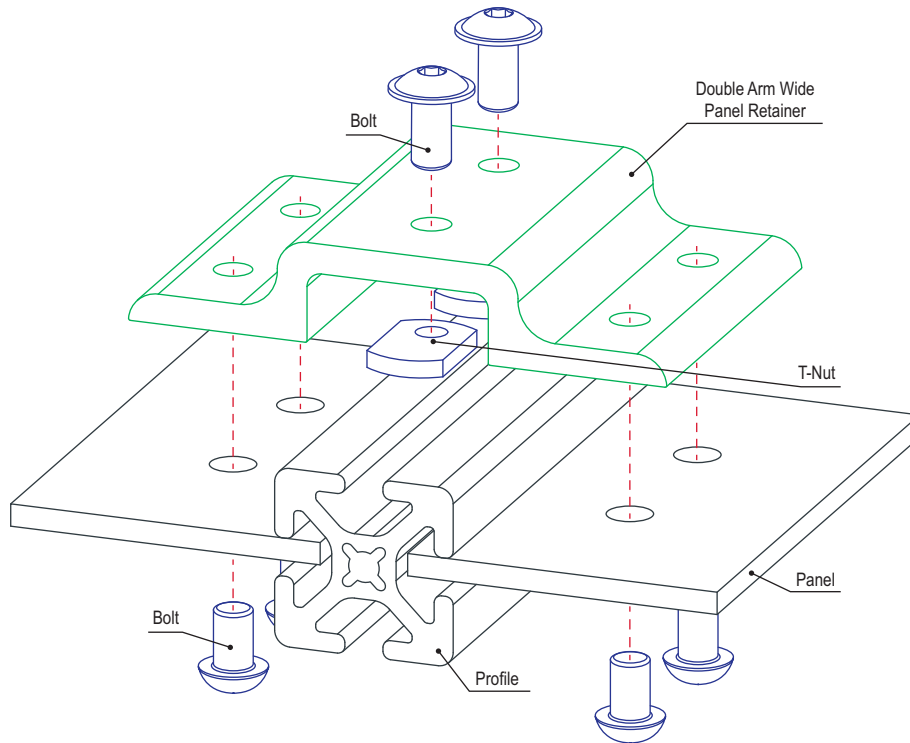

Single Arm Narrow Mesh Retainer

Part Description:

The single arm narrow mesh retainer is used to mount a mesh panel when it is recessed within the T-slot or on the profile frame. It provides stability and reduces vibration while also being a strong fastening option that is simple to use and can be easily repositioned. The single arm narrow mesh retainer is frequently used when mounting one mesh panel to a profile or in instances when larger profile series are used to mount two mesh panels. It has a slotted hole to allow for positioning so that the bolt doesn't crash into the mesh. The mesh retainer requires a backing plate, which can be found on page 498. The suggested hardware to mount the retainer to the T-slot is listed below while the hardware for the backing plate should be based on the panel type and thickness.

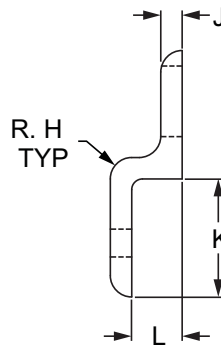
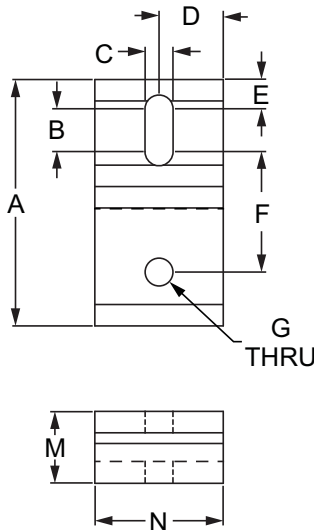

Part No.	Series	A	B	C	D	E	F	G	H	J	K	L	M	N	Weight
2490	10	1.938"	.375"	.257"	.500"	.250"	.875"	.257"	.188"	.188"	.938"	.375"	.563"	1.000"	.037 lb
2490-Black	10	1.938"	.375"	.257"	.500"	.250"	.875"	.257"	.188"	.188"	.938"	.375"	.563"	1.000"	.037 lb
2432	15	2.879"	.500"	.328"	.750"	.344"	1.406"	.328"	.250"	.250"	1.379"	.590"	.840"	1.500"	.113 lb
2432-Black	15	2.879"	.500"	.328"	.750"	.344"	1.406"	.328"	.250"	.250"	1.379"	.590"	.840"	1.500"	.113 lb
20-2490	20	39.00mm	5.46mm	5.54mm	10.00mm	5.77mm	19.25mm	5.54mm	3.00mm	3.00mm	19.00mm	7.19mm	10.19mm	20.00mm	.0059 kg
20-2490-Black	20	39.00mm	5.46mm	5.54mm	10.00mm	5.77mm	19.25mm	5.54mm	3.00mm	3.00mm	19.00mm	7.19mm	10.19mm	20.00mm	.0059 kg
25-2490	25	48.50mm	9.40mm	6.30mm	16.00mm	6.00mm	22.10mm	6.30mm	4.00mm	4.00mm	23.50mm	9.30mm	13.31mm	32.00mm	.0178 kg
25-2490-Black	25	48.50mm	9.40mm	6.30mm	16.00mm	6.00mm	22.10mm	6.30mm	4.00mm	4.00mm	23.50mm	9.30mm	13.31mm	32.00mm	.0178 kg
30-2432	30	58.00mm	9.75mm	8.28mm	15.00mm	8.13mm	27.64mm	8.28mm	4.00mm	4.00mm	28.00mm	10.60mm	14.60mm	30.00mm	.0499 kg
30-2432-Black	30	58.00mm	9.75mm	8.28mm	15.00mm	8.13mm	27.64mm	8.28mm	4.00mm	4.00mm	28.00mm	10.60mm	14.60mm	30.00mm	.0499 kg
40-2432	40	77.00mm	13.31mm	8.28mm	20.00mm	9.00mm	37.90mm	8.28mm	6.00mm	6.00mm	37.00mm	16.00mm	22.00mm	40.00mm	.0536 kg
40-2432-Black	40	77.00mm	13.31mm	8.28mm	20.00mm	9.00mm	37.90mm	8.28mm	6.00mm	6.00mm	37.00mm	16.00mm	22.00mm	40.00mm	.0536 kg
45-2432	45	87.00mm	18.69mm	8.28mm	22.50mm	10.16mm	39.14mm	8.28mm	6.00mm	6.00mm	42.00mm	17.30mm	23.29mm	45.00mm	.0692 kg
45-2432-Black	45	87.00mm	18.69mm	8.28mm	22.50mm	10.16mm	39.14mm	8.28mm	6.00mm	6.00mm	42.00mm	17.30mm	23.29mm	45.00mm	.0692 kg

CONTINUE

80/20[®] Inc. Single Arm Narrow Mesh Retainer (Continued)

Material Specifications

Part No.	Material	Alloy*	Process	Finish
2490	Aluminum	6105-T5	Milled	Clear Anodize
2490-Black				Black Anodize
2432				Clear Anodize
2432-Black				Black Anodize
20-2490				Clear Anodize
20-2490-Black				Black Anodize
25-2490				Clear Anodize
25-2490-Black				Black Anodize
30-2432				Clear Anodize
30-2432-Black				Black Anodize
40-2432				Clear Anodize
40-2432-Black				Black Anodize
45-2432				Clear Anodize
45-2432-Black				Black Anodize

* Or comparable

Suggested Hardware (Mount to T-Slot)

Part No.	Series	Qty.	Bolt	T-Nut
3321	10	1	1/4-20 x 1/2 FBHSCS	Economy
3320	15	1	5/16-18 x 11/16 FBHSCS	Economy
75-3581	20	1	M5 x 8mm BHSCS	Economy
75-3404	25	1	M6 x 10mm BHSCS	Economy
75-3615	30	1	M8 x 12mm BHSCS	Roll-in
75-3422	40	1	M8 x 16mm BHSCS	Economy
75-3619	45	1	M8 x 18mm BHSCS	Drop-in

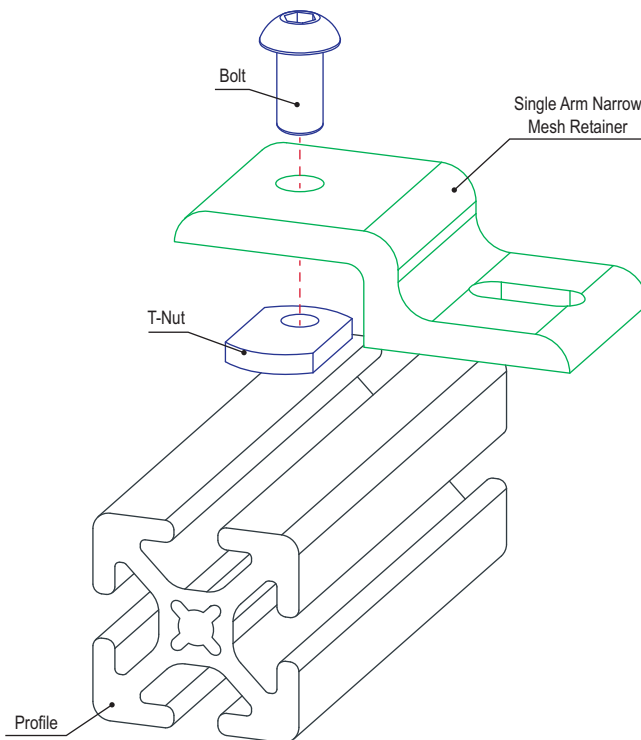

Single Arm Wide Mesh Retainer

Part Description:

The single arm wide mesh retainer is used to mount a mesh panel when it is recessed within the T-slot or on the profile frame. It provides stability and reduces vibration while also being a strong fastening option that is simple to use and easily repositioned. The single arm wide mesh retainer is frequently used when mounting one mesh panel to a profile or in instances when larger profile series are used to mount two mesh panels. It has slotted holes to allow for positioning so that the bolts don't crash into the mesh. The mesh retainer requires a backing plate, which can be found on page 499. The suggested hardware to mount the retainer to the T-slot is listed below while the hardware for the backing plate should be based on the panel type and thickness.

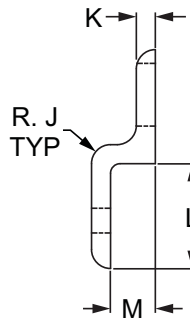
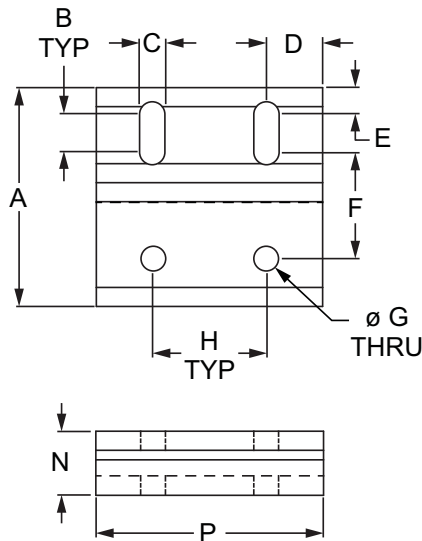

Part No.	Series	A	B	C	D	E	F	G	H	J	K	L	M	N	P	Weight
2493	10	1.938"	.375"	.257"	.500"	.250"	.875"	.257"	1.000"	.188"	.188"	.938"	.375"	.563"	2.000"	.073 lb
2493-Black	10	1.938"	.375"	.257"	.500"	.250"	.875"	.257"	1.000"	.188"	.188"	.938"	.375"	.563"	2.000"	.073 lb
2431	15	2.879"	.500"	.328"	.750"	.344"	1.406"	.328"	1.500"	.250"	.250"	1.379"	.590"	.840"	3.000"	.228 lb
2431-Black	15	2.879"	.500"	.328"	.750"	.344"	1.406"	.328"	1.500"	.250"	.250"	1.379"	.590"	.840"	3.000"	.228 lb
20-2493	20	39.00mm	27.77mm	5.54mm	10.00mm	5.77mm	19.25mm	5.54mm	20.00mm	3.00mm	3.00mm	19.00mm	7.18mm	10.19mm	40.00mm	.0127 kg
20-2493-Black	20	39.00mm	27.77mm	5.54mm	10.00mm	5.77mm	19.25mm	5.54mm	20.00mm	3.00mm	3.00mm	19.00mm	7.18mm	10.19mm	40.00mm	.0127 kg
25-2493	25	48.49mm	9.40mm	6.30mm	12.50mm	6.00mm	22.10mm	6.30mm	25.00mm	4.00mm	4.00mm	23.50mm	9.30mm	13.30mm	50.00mm	.0124 kg
25-2493-Black	25	48.49mm	9.40mm	6.30mm	12.50mm	6.00mm	22.10mm	6.30mm	25.00mm	4.00mm	4.00mm	23.50mm	9.30mm	13.30mm	50.00mm	.0124 kg
30-2431	30	58.00mm	9.75mm	8.28mm	15.00mm	8.13mm	27.64mm	8.28mm	30.00mm	4.00mm	4.00mm	28.00mm	10.60mm	14.58mm	60.00mm	.0369 kg
30-2431-Black	30	58.00mm	9.75mm	8.28mm	15.00mm	8.13mm	27.64mm	8.28mm	30.00mm	4.00mm	4.00mm	28.00mm	10.60mm	14.58mm	60.00mm	.0369 kg
40-2431	40	77.00mm	13.31mm	8.28mm	20.00mm	9.00mm	37.90mm	8.28mm	40.00mm	6.00mm	6.00mm	37.00mm	16.00mm	22.00mm	80.00mm	.1074 kg
40-2431-Black	40	77.00mm	13.31mm	8.28mm	20.00mm	9.00mm	37.90mm	8.28mm	40.00mm	6.00mm	6.00mm	37.00mm	16.00mm	22.00mm	80.00mm	.1074 kg
45-2431	45	87.00mm	18.69mm	8.28mm	22.50mm	10.16mm	39.14mm	8.28mm	45.00mm	6.00mm	6.00mm	41.00mm	17.30mm	23.30mm	90.00mm	.1372 kg
45-2431-Black	45	87.00mm	18.69mm	8.28mm	22.50mm	10.16mm	39.14mm	8.28mm	45.00mm	6.00mm	6.00mm	41.00mm	17.30mm	23.30mm	90.00mm	.1372 kg

CONTINUE

80/20[®] Inc. Single Arm Wide Mesh Retainer (Continued)

Material Specifications

Part No.	Material	Alloy*	Process	Finish
2493	Aluminum	6105-T5	Milled	Clear Anodize
2493-Black				Black Anodize
2431				Clear Anodize
2431-Black				Black Anodize
20-2493				Clear Anodize
20-2493-Black				Black Anodize
25-2493				Clear Anodize
25-2493-Black				Black Anodize
30-2431				Clear Anodize
30-2431-Black				Black Anodize
40-2431				Clear Anodize
40-2431-Black				Black Anodize
45-2431				Clear Anodize
45-2431-Black				Black Anodize

* Or comparable

Suggested Hardware (Mount to T-Slot)

Part No.	Series	Qty.	Bolt	T-Nut
3321	10	2	1/4-20 x 1/2 FBHSCS	Economy
3320	15	2	5/16-18 x 11/16 FBHSCS	Economy
75-3581	20	2	M5 x 8mm BHSCS	Economy
75-3404	25	2	M6 x 10mm BHSCS	Economy
75-3615	30	2	M8 x 12mm BHSCS	Roll-in
75-3422	40	2	M8 x 16mm BHSCS	Economy
75-3619	45	2	M8 x 18mm BHSCS	Drop-in

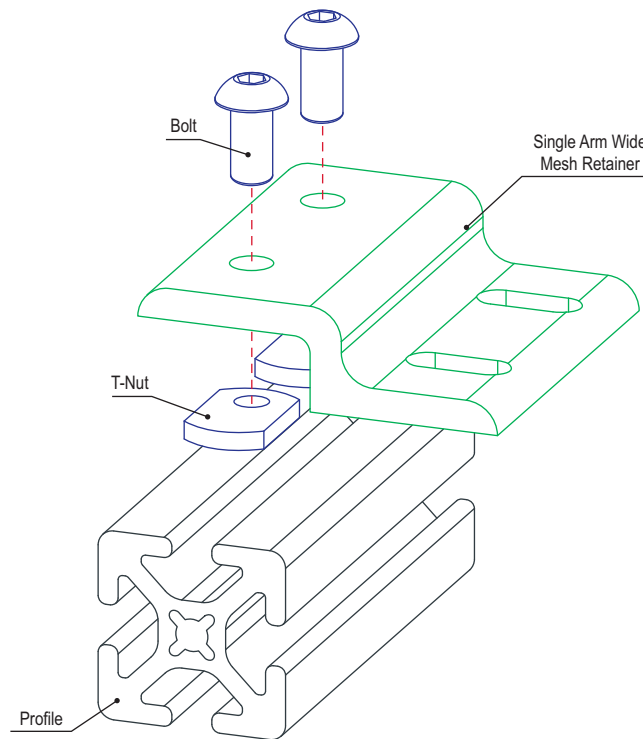

Double Arm Narrow Mesh Retainer



Part Description:

The double arm narrow mesh retainer is used to mount a mesh panel when it is recessed within the T-slot or on the profile frame. It provides stability and reduces vibration while also being a strong fastening option that is simple to use and easily repositioned. The double arm narrow mesh retainer is perfect in instances when a profile is connecting two adjacent panels. It has slotted holes to allow for positioning so that the bolts won't crash into the mesh. The mesh retainer requires backing plates, which can be found on page 498. The suggested hardware to mount the retainer to the T-slot is listed below while the hardware for the backing plates should be based on the panel type and thickness.

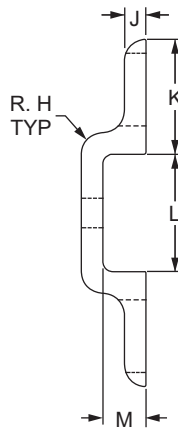
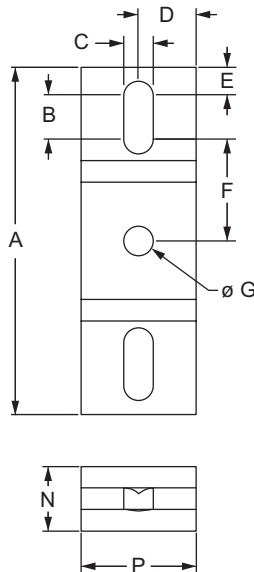

PANELS & DOORS

Part No.	Series	A	B	C	D	E	F	G	H	J	K	L	M	N	P	Weight
2521	10	3.020"	.375"	.257"	.500"	.249"	.886"	.257"	.188"	.188"	1.000"	1.020"	.375"	.563"	1.000"	.061 lb
2521-Black	10	3.020"	.375"	.257"	.500"	.249"	.886"	.257"	.188"	.188"	1.000"	1.020"	.375"	.563"	1.000"	.061 lb
2517	15	4.522"	.500"	.328"	.750"	.344"	1.417"	.328"	.250"	.250"	1.500"	1.522"	.590"	.840"	1.500"	.188 lb
2517-Black	15	4.522"	.500"	.328"	.750"	.344"	1.417"	.328"	.250"	.250"	1.500"	1.522"	.590"	.840"	1.500"	.188 lb
25-2521	25	75.50mm	9.40mm	6.30mm	16.00mm	6.00mm	22.35mm	6.30mm	4.00mm	4.00mm	25.00mm	25.50mm	9.30mm	13.30mm	32.00mm	.0288 kg
25-2521-Black	25	75.50mm	9.40mm	6.30mm	16.00mm	6.00mm	22.35mm	6.30mm	4.00mm	4.00mm	25.00mm	25.50mm	9.30mm	13.30mm	32.00mm	.0288 kg
40-2517	40	120.59mm	13.30mm	8.30mm	20.00mm	9.00mm	38.00mm	8.30mm	6.00mm	6.00mm	40.00mm	40.59mm	15.95mm	21.95mm	40.00mm	.0913 kg
40-2517-Black	40	120.59mm	13.30mm	8.30mm	20.00mm	9.00mm	38.00mm	8.30mm	6.00mm	6.00mm	40.00mm	40.59mm	15.95mm	21.95mm	40.00mm	.0913 kg

CONTINUE

Double Arm Narrow Mesh Retainer (Continued)

Material Specifications

Part No.	Material	Alloy*	Process	Finish
2521	Aluminum	6105-T5	Milled	Clear Anodize
2521-Black				Black Anodize
2517				Clear Anodize
2517-Black				Black Anodize
25-2521				Clear Anodize
25-2521-Black				Black Anodize
40-2517				Clear Anodize
40-2517-Black				Black Anodize

* Or comparable

Suggested Hardware (Mount to T-Slot)

Part No.	Series	Qty.	Bolt	T-Nut
3321	10	1	1/4-20 x 1/2 FBHSCS	Economy
3320	15	1	5/16-18 x 11/16 FBHSCS	Economy
75-3404	25	1	M6 x 10mm BHSCS	Economy
75-3422	40	1	M8 x 16mm BHSCS	Economy

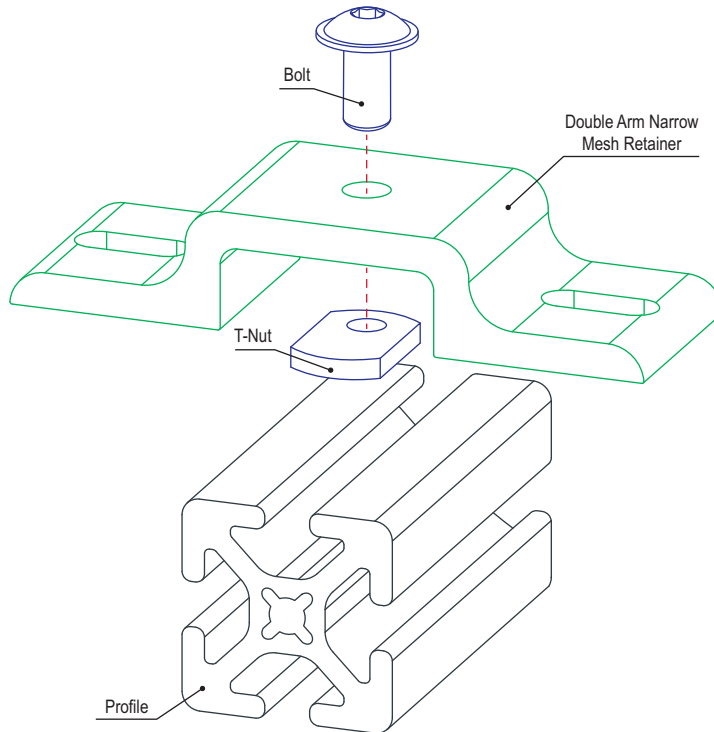

Double Arm Wide Mesh Retainer

Part Description:

The double arm wide mesh retainer is used to mount a mesh panel when it is recessed within the T-slot or on the profile frame. It provides stability and reduces vibration. The wide arm makes this a stronger connection that is simple to use and can be easily repositioned. The double arm wide mesh retainer is perfect in instances when a profile is connecting two adjacent panels. It has slotted holes to allow for positioning so that the bolts don't crash into the mesh. The double arm wide mesh retainer requires backing plates, which can be found on page 499. The suggested hardware to mount the retainer to the T-slot is listed below while the hardware for the backing plates should be based on the panel type and thickness.

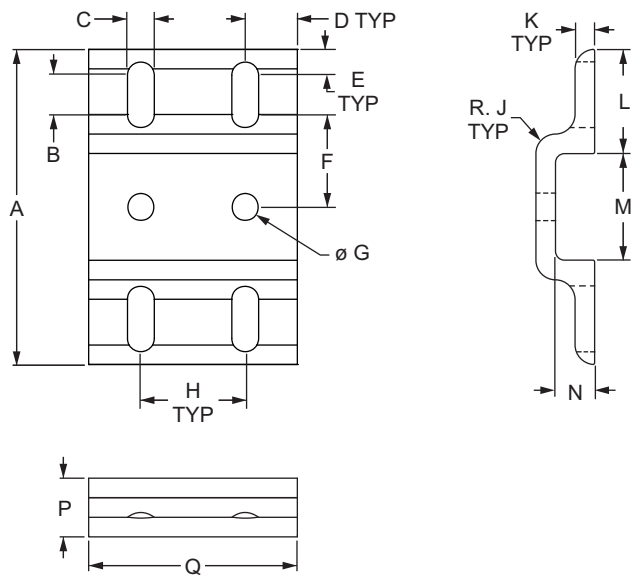

Part No.	Series	A	B	C	D	E	F	G	H	J	K	L	M	N	P	Q	Weight
2523	10	3.020"	.375"	.257"	.500"	.250"	.886"	.257"	1.000"	.188"	.188"	1.000"	1.020"	.375"	.563"	2.000"	.118 lb
2523-Black	10	3.020"	.375"	.257"	.500"	.250"	.886"	.257"	1.000"	.188"	.188"	1.000"	1.020"	.375"	.563"	2.000"	.118 lb
2519	15	4.523"	.500"	.328"	.750"	.344"	1.418"	.328"	1.500"	.250"	.250"	1.500"	1.523"	.590"	.840"	3.000"	.377 lb
2519-Black	15	4.523"	.500"	.328"	.750"	.344"	1.418"	.328"	1.500"	.250"	.250"	1.500"	1.523"	.590"	.840"	3.000"	.377 lb
25-2523	25	75.50mm	9.40mm	6.30mm	12.50mm	6.00mm	22.35mm	6.30mm	25.00mm	4.00mm	4.00mm	25.00mm	25.50mm	9.30mm	13.40mm	50.00mm	.0439 kg
25-2523-Black	25	75.50mm	9.40mm	6.30mm	12.50mm	6.00mm	22.35mm	6.30mm	25.00mm	4.00mm	4.00mm	25.00mm	25.50mm	9.30mm	13.40mm	50.00mm	.0439 kg
40-2519	40	120.60mm	13.30mm	8.30mm	20.00mm	9.00mm	38.00mm	8.30mm	40.00mm	6.00mm	6.00mm	40.00mm	40.60mm	16.00mm	22.00mm	80.00mm	.1796 kg
40-2519-Black	40	120.60mm	13.30mm	8.30mm	20.00mm	9.00mm	38.00mm	8.30mm	40.00mm	6.00mm	6.00mm	40.00mm	40.60mm	16.00mm	22.00mm	80.00mm	.1796 kg

CONTINUE →

Material Specifications

Part No.	Material	Alloy*	Process	Finish
2523	Aluminum	6105-T5	Milled	Clear Anodize
2523-Black				Black Anodize
2519				Clear Anodize
2519-Black				Black Anodize
25-2523				Clear Anodize
25-2523-Black				Black Anodize
40-2519				Clear Anodize
40-2519-Black				Black Anodize

* Or comparable

Suggested Hardware (Mount to T-Slot)

Part No.	Series	Qty.	Bolt	T-Nut
3321	10	2	1/4-20 x 1/2 FBHSCS	Economy
3320	15	2	5/16-18 x 11/16 FBHSCS	Economy
75-3404	25	2	M6 x 10mm BHSCS	Economy
75-3422	40	2	M8 x 16mm BHSCS	Economy

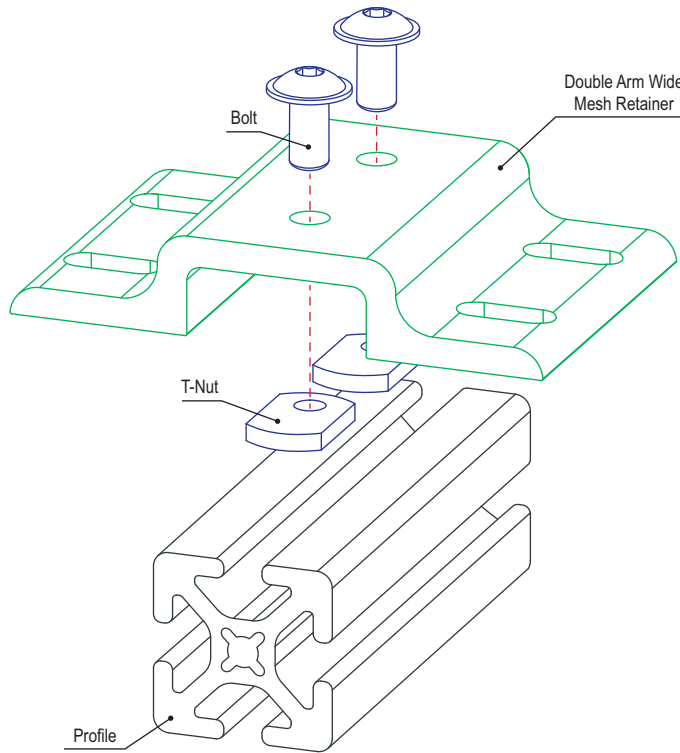

Narrow Backing Plate

Part Description:

The narrow backing plate is used with the single arm narrow mesh retainer (page 490) or the double arm narrow mesh retainer (page 494) to secure wire mesh or panels. The suggested hardware for the narrow backing plate should be based on the mesh or panel type and thickness.

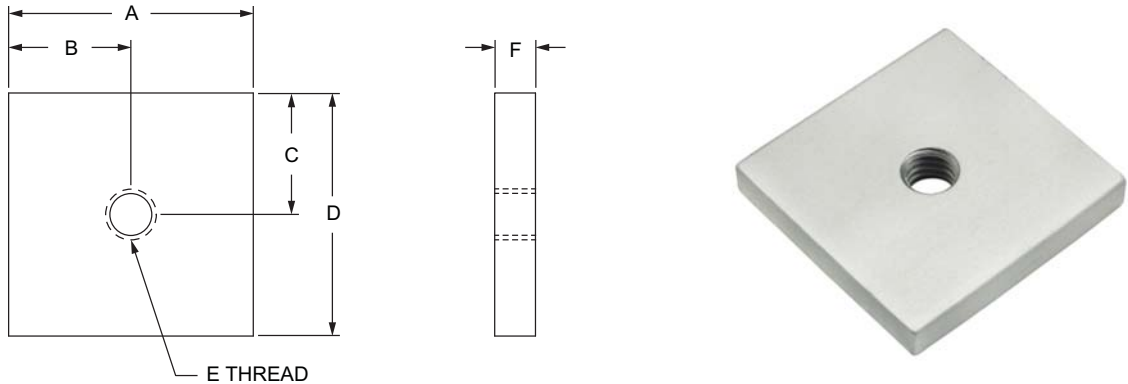

Part No.	Series	Material	Alloy*	Process	Finish	A	B	C	D	E	F	Weight
2492	10	Aluminum	6105-T5	Milled	Clear Anodize	1.000"	.500"	.500"	1.000"	1/4-20	.188"	.018 lb
2492-Black	10				Black Anodize	1.000"	.500"	.500"	1.000"	1/4-20	.188"	.018 lb
2438	15				Clear Anodize	1.50"	.750"	.745"	1.49"	5/16-18	.250"	.053 lb
2438-Black	15				Black Anodize	1.50"	.750"	.745"	1.49"	5/16-18	.250"	.053 lb
20-2492	20				Clear Anodize	32.00mm	16.00mm	9.53mm	19.05mm	M5 x 0.8	4.78mm	.0077 kg
20-2492-Black	20				Black Anodize	32.00mm	16.00mm	9.53mm	19.05mm	M5 x 0.8	4.78mm	.0077 kg
25-2492	25				Clear Anodize	32.00mm	16.00mm	12.50mm	25.00mm	M6 x 1.0	4.00mm	.0081kg
25-2492-Black	25				Black Anodize	32.00mm	16.00mm	12.50mm	25.00mm	M6 x 1.0	4.00mm	.0081 kg
30-2438	30				Clear Anodize	30.00mm	15.00mm	12.50mm	25.00mm	M8 x 1.25	4.00mm	.0100 kg
30-2438-Black	30				Black Anodize	30.00mm	15.00mm	12.50mm	25.00mm	M8 x 1.25	4.00mm	.0100 kg
40-2438	40				Clear Anodize	40.00mm	20.00mm	19.89mm	39.80mm	M8 x 1.25	6.00mm	.0245 kg
40-2438-Black	40				Black Anodize	40.00mm	20.00mm	19.89mm	39.80mm	M8 x 1.25	6.00mm	.0245 kg
45-2438	45				Clear Anodize	45.00mm	22.50mm	19.89mm	39.80mm	M8 x 1.25	6.00mm	.0278 kg
45-2438-Black	45				Black Anodize	45.00mm	22.50mm	19.89mm	39.80mm	M8 x 1.25	6.00mm	.0278 kg

* Or comparable

Suggested Hardware (Mount to Backing Plate)

Part No.	Series	Qty.	Bolt
3063	10	1	1/4-20 x 1/2 BHSCS
3114	15	1	5/16-18 x 11/16 BHSCS
11-5310	20	1	M5 x 10mm BHSCS
13-6312	25	1	M6 x 12mm BHSCS
11-8316	30	1	M8 x 16mm BHSCS
13-8320	40	1	M8 x 20mm BHSCS
11-8318	45	1	M8 x 18mm BHSCS

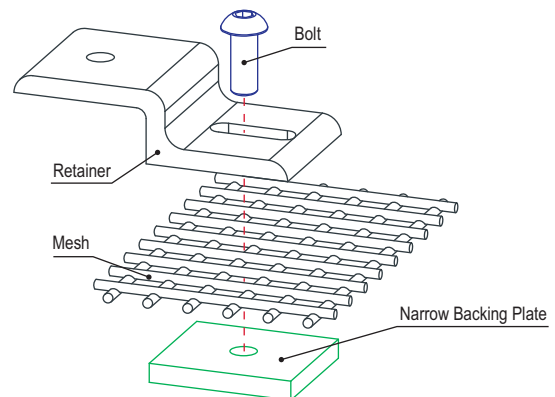

Part Description:

The wide backing plate is used with the single arm wide mesh retainer (page 492) or the double arm wide mesh retainer (page 496) to secure wire mesh or panels. The suggested hardware for the wide backing plate should be based on the mesh or panel type and thickness.

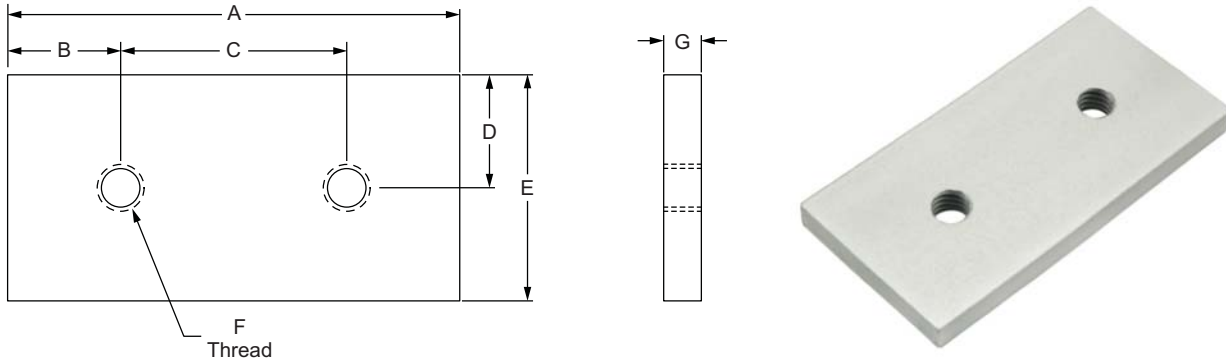

Part No.	Series	Material	Alloy*	Process	Finish	A	B	C	D	E	F	G	Weight
2495	10	Aluminum	6105-T5	Milled	Clear Anodize	2.000"	.500"	1.000"	.500"	1.000"	1/4-20	.188"	.036 lb
2495-Black	10				Black Anodize	2.000"	.500"	1.000"	.500"	1.000"	1/4-20	.188"	.036 lb
2437	15				Clear Anodize	3.000"	.750"	1.500"	.745"	1.49"	5/16-18	.250"	.104 lb
2437-Black	15				Black Anodize	3.000"	.750"	1.500"	.745"	1.49"	5/16-18	.250"	.104 lb
20-2495	20				Clear Anodize	40.00mm	10.00mm	20.00mm	9.53mm	19.05mm	M5 x 0.8	4.78mm	.0095 kg
20-2495-Black	20				Black Anodize	40.00mm	10.00mm	20.00mm	9.53mm	19.05mm	M5 x 0.8	4.78mm	.0095 kg
25-2495	25				Clear Anodize	50.00mm	12.50mm	25.00mm	12.50mm	25.00mm	M6 x 1.0	4.00mm	.0127 kg
25-2495-Black	25				Black Anodize	50.00mm	12.50mm	25.00mm	12.50mm	25.00mm	M6 x 1.0	4.00mm	.0127 kg
30-2437	30				Clear Anodize	60.00mm	15.00mm	30.00mm	12.50mm	25.00mm	M8 x 1.25	4.00mm	.0150 kg
30-2437-Black	30				Black Anodize	60.00mm	15.00mm	30.00mm	12.50mm	25.00mm	M8 x 1.25	4.00mm	.0150 kg
40-2437	40				Clear Anodize	80.00mm	20.00mm	40.00mm	19.89mm	39.80mm	M8 x 1.25	6.00mm	.0490 kg
40-2437-Black	40				Black Anodize	80.00mm	20.00mm	40.00mm	19.89mm	39.80mm	M8 x 1.25	6.00mm	.0490 kg
45-2437	45				Clear Anodize	90.00mm	22.50mm	45.00mm	19.89mm	39.80mm	M8 x 1.25	6.00mm	.0553 kg
45-2437-Black	45				Black Anodize	90.00mm	22.50mm	45.00mm	19.89mm	39.80mm	M8 x 1.25	6.00mm	.0553 kg

* Or comparable

Suggested Hardware (Mount to Backing Plate)

Part No.	Series	Qty.	Bolt
3063	10	2	1/4-20 x 1/2 BHSCS
3114	15	2	5/16-18 x 11/16 BHSCS
11-5310	20	2	M5 x 10mm BHSCS
13-6312	25	2	M6 x 12mm BHSCS
11-8316	30	2	M8 x 16mm BHSCS
13-8320	40	2	M8 x 20mm BHSCS
11-8318	45	2	M8 x 18mm BHSCS

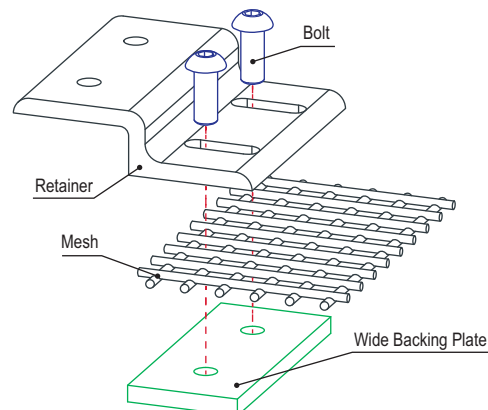

Single Arm Narrow Mesh Retainer with Narrow Backing Plate

Part Description:

The single arm narrow mesh retainer with narrow backing plate consists of one single arm narrow mesh retainer (page 490) and one narrow backing plate (page 498). The hardware to attach the backing plate to the retainer should be selected based on the wire mesh panel type and thickness. The suggested hardware to mount the retainer to the T-slot can be found on below.

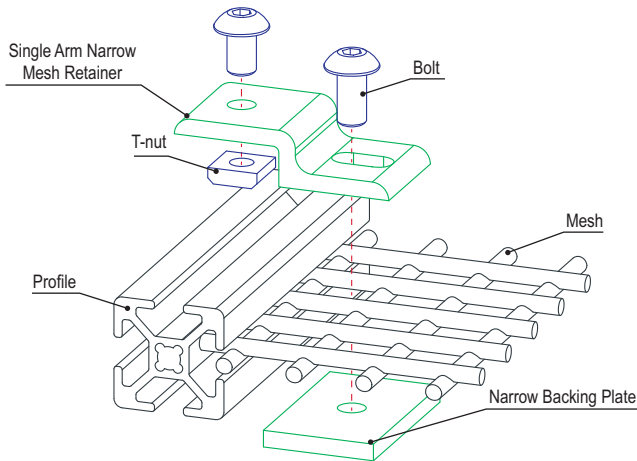

Part No.	Series	Material	Alloy*	Process	Finish	Weight
2491	10	Aluminum	6105-T5	Milled	Clear Anodize	.054 lb
2491-Black	10				Black Anodize	.054 lb
2436	15				Clear Anodize	.165 lb
2436-Black	15				Black Anodize	.165 lb
20-2491	20				Clear Anodize	.0222 kg
20-2491-Black	20				Black Anodize	.0222 kg
25-2491	25				Clear Anodize	.0259 kg
25-2491-Black	25				Black Anodize	.0259 kg
30-2436	30				Clear Anodize	.0259 kg
30-2436-Black	30				Black Anodize	.0259 kg
40-2436	40				Clear Anodize	.0786 kg
40-2436-Black	40				Black Anodize	.0786 kg
45-2436	45				Clear Anodize	.0970 kg
45-2436-Black	45				Black Anodize	.0970 kg

* Or comparable

Suggested Hardware (Mount to T-Slot)

Part No.	Series	Qty.	Bolt	T-Nut
3321	10	1	1/4-20 x 1/2 FBHSCS	Economy
3320	15	1	5/16-18 x 11/16 FBHSCS	Economy
75-3581	20	1	M5 x 8mm BHSCS	Economy
75-3404	25	1	M6 x 10mm BHSCS	Economy
75-3615	30	1	M8 x 12mm BHSCS	Roll-in
75-3422	40	1	M8 x 16mm BHSCS	Economy
75-3619	45	1	M8 x 18mm BHSCS	Drop-in

Suggested Hardware (Mount to Backing Plate)

Part No.	Series	Qty.	Bolt
3063	10	1	1/4-20 x 1/2 BHSCS
3114	15	1	5/16-18 x 11/16 BHSCS
11-5310	20	1	M5 x 10mm BHSCS
13-6312	25	1	M6 x 12mm BHSCS
11-8316	30	1	M8 x 16mm BHSCS
13-8320	40	1	M8 x 20mm BHSCS
11-8318	45	1	M8 x 18mm BHSCS

80/20®
Single Arm Wide Mesh Retainer with Wide Backing Plate

Part Description:

The single arm wide mesh retainer with wide backing plate consists of one single arm wide mesh retainer (page 492) and one wide backing plate (page 499). The hardware to attach the backing plate to the retainer should be selected based on the wire mesh panel type and thickness. The suggested hardware to mount the retainer to the T-slot can be found below.

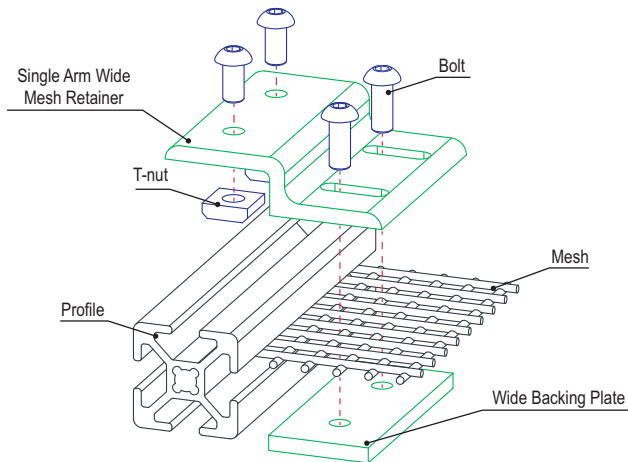

Part No.	Series	Material	Alloy*	Process	Finish	Weight
2494	10	Aluminum	6105-T5	Milled	Clear Anodize	.109 lb
2494-Black	10				Black Anodize	.109 lb
2435	15				Clear Anodize	.331 lb
2435-Black	15				Black Anodize	.331 lb
20-2494	20				Clear Anodize	.0218 kg
20-2494-Black	20				Black Anodize	.0218 kg
25-2494	25				Clear Anodize	.0400 kg
25-2494-Black	25				Black Anodize	.0400 kg
30-2435	30				Clear Anodize	.0517 kg
30-2435-Black	30				Black Anodize	.0517 kg
40-2435	40				Clear Anodize	.1565 kg
40-2435-Black	40				Black Anodize	.1565 kg
45-2435	45				Clear Anodize	.1918 kg
45-2435-Black	45				Black Anodize	.1918 kg

* Or comparable

Suggested Hardware (Mount to T-Slot)

Part No.	Series	Qty.	Bolt	T-Nut
3321	10	2	1/4-20 x 1/2 FBHSCS	Economy
3320	15	2	5/16-18 x 11/16 FBHSCS	Economy
75-3581	20	2	M5 x 8mm BHSCS	Economy
75-3404	25	2	M6 x 10mm BHSCS	Economy
75-3615	30	2	M8 x 12mm BHSCS	Roll-in
75-3422	40	2	M8 x 16mm BHSCS	Economy
75-3619	45	2	M8 x 18mm BHSCS	Drop-in

Suggested Hardware (Mount to Backing Plate)

Part No.	Series	Qty.	Bolt
3063	10	2	1/4-20 x 1/2 BHSCS
3114	15	2	5/16-18 x 11/16 BHSCS
11-5310	20	2	M5 x 10mm BHSCS
13-6312	25	2	M6 x 12mm BHSCS
11-8316	30	2	M8 x 16mm BHSCS
13-8320	40	2	M8 x 20mm BHSCS
11-8318	45	2	M8 x 18mm BHSCS

Double Arm Narrow Mesh Retainer with Narrow Backing Plates

Part Description:

The double arm narrow mesh retainer with narrow backing plates consists of one double arm narrow mesh retainer (page 494) and two narrow backing plates (page 498). The hardware to attach the backing plates to the retainer should be selected based on the wire mesh panel type and thickness. The suggested hardware to mount the retainer to the T-slot can be found below.

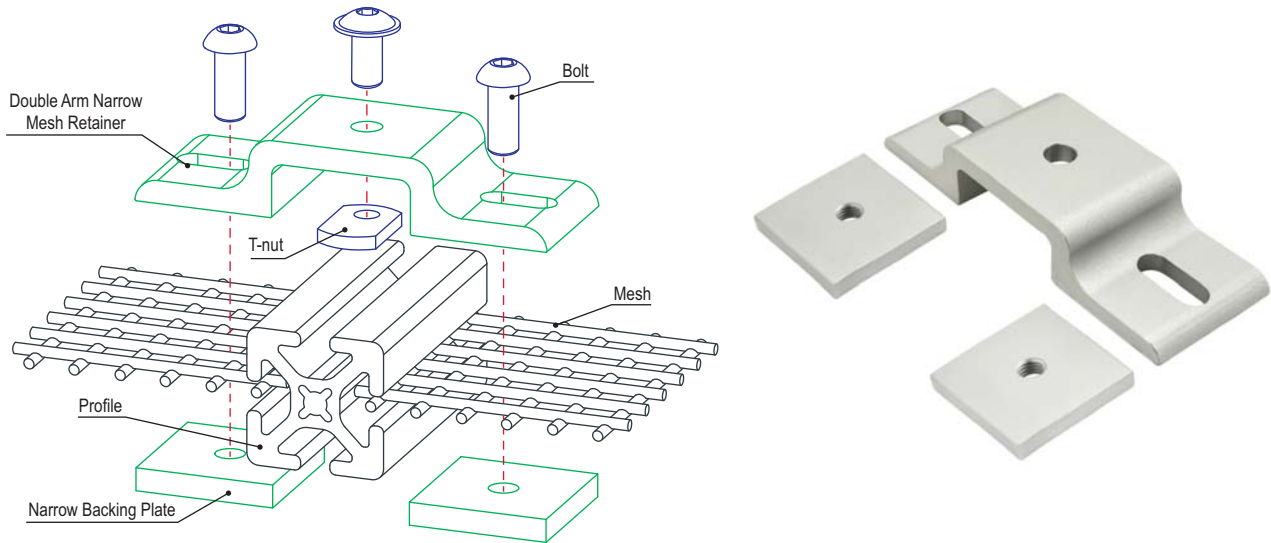

Part No.	Series	Material	Alloy*	Process	Finish	Weight
2522	10	Aluminum	6105-T5	Milled	Clear Anodize	.077 lb
2522-Black	10				Black Anodize	.077 lb
2518	15				Clear Anodize	.240 lb
2518-Black	15				Black Anodize	.240lb
25-2522	25				Clear Anodize	.0448 kg
25-2522-Black	25				Black Anodize	.0448 kg
40-2518	40				Clear Anodize	.1398 kg
40-2518-Black	40				Black Anodize	.1398 kg

* Or comparable

Suggested Hardware (Mount to T-Slot)

Part No.	Series	Qty.	Bolt	T-Nut
3321	10	1	1/4-20 x 1/2 FBHSCS	Economy
3320	15	1	5/16-18 x 11/16 FBHSCS	Economy
75-3404	25	1	M6 x 10mm BHSCS	Economy
75-3422	40	1	M8 x 16mm BHSCS	Economy

Suggested Hardware (Mount to Backing Plate)

Part No.	Series	Qty.	Bolt
3063	10	2	1/4-20 x 1/2 BHSCS
3114	15	2	5/16-18 x 11/16 BHSCS
13-6312	25	2	M6 x 12mm BHSCS
13-8320	40	2	M8 x 20mm BHSCS

80/20®
Double Arm Wide Mesh Retainer with Wide Backing Plates

Part Description:

The double arm wide mesh retainer with wide backing plates consists of one double arm wide mesh retainer (page 496) and two wide backing plates (page 499). The hardware to attach the backing plates to the retainer should be selected based on the wire mesh panel type and thickness. The suggested hardware to mount the retainer to the T-slot can be found below.

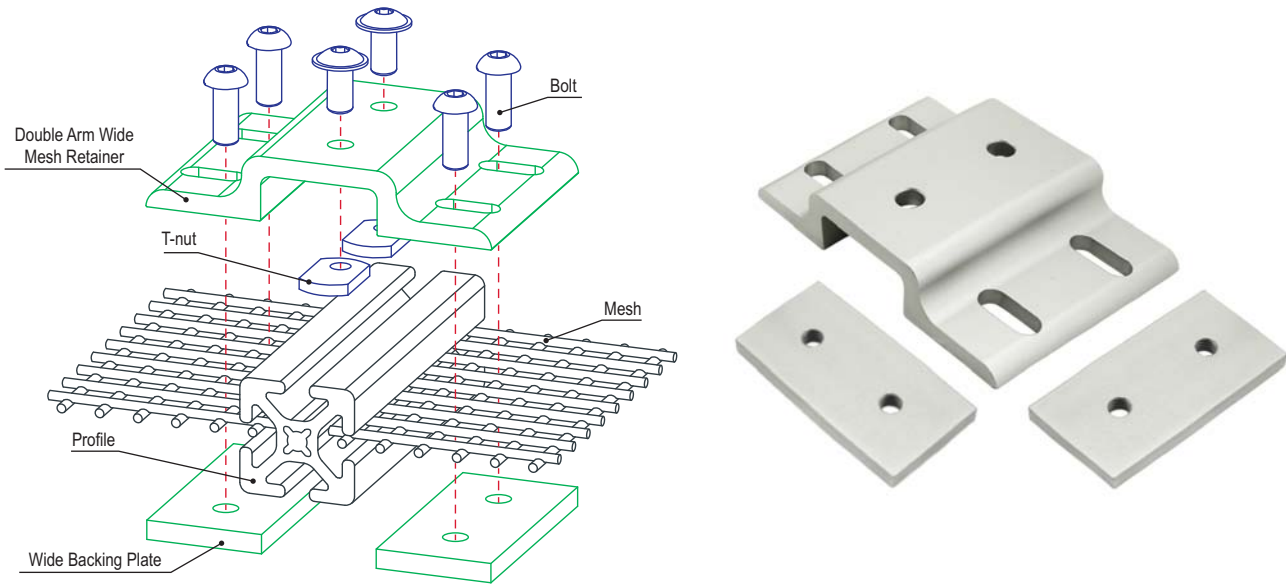

Part No.	Series	Material	Alloy*	Process	Finish	Weight
2524	10	Aluminum	6105-T5	Milled	Clear Anodize	.157 lb
2524-Black	10				Black Anodize	.157 lb
2520	15				Clear Anodize	.482 lb
2520-Black	15				Black Anodize	.482 lb
25-2524	25				Clear Anodize	.1157 kg
25-2524-Black	25				Black Anodize	.1157 kg
40-2520	40				Clear Anodize	.2807 kg
40-2520-Black	40				Black Anodize	.2807 kg

* Or comparable

Suggested Hardware (Mount to T-Slot)

Part No.	Series	Qty.	Bolt	T-Nut
3321	10	2	1/4-20 x 1/2 FBHSCS	Economy
3320	15	2	5/16-18 x 11/16 FBHSCS	Economy
75-3404	25	2	M6 x 10mm BHSCS	Economy
75-3422	40	2	M8 x 16mm BHSCS	Economy

Suggested Hardware (Mount to Backing Plate)

Part No.	Series	Qty.	Bolt
3063	10	4	1/4-20 x 1/2 BHSCS
3114	15	4	5/16-18 x 11/16 BHSCS
13-6312	25	4	M6 x 12mm BHSCS
13-8320	40	4	M8 x 20mm BHSCS

Single & Dual Panel Holder

Part Description:

The single and dual panel holders are both zinc die-cast and provide quick and simple methods to secure panels. The pads on the holders increase the strength and help to protect the panel. The dual panel holder is frequently used in conjunction with two single panel holders to form a frameless plastic panel corner. The single panel holder is comprised of two pieces and the hardware to connect them. The dual panel holder includes the hardware to mount to the single panel holders.

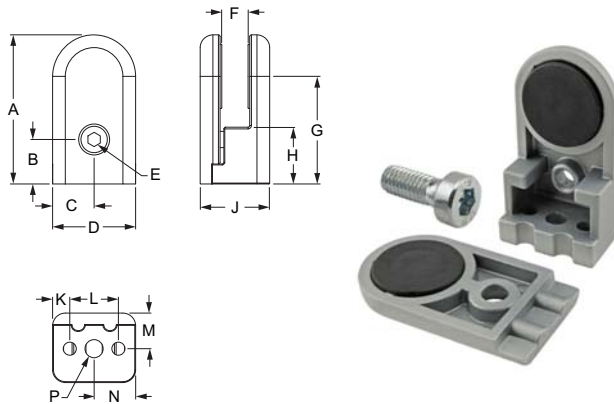

Single Panel Holder

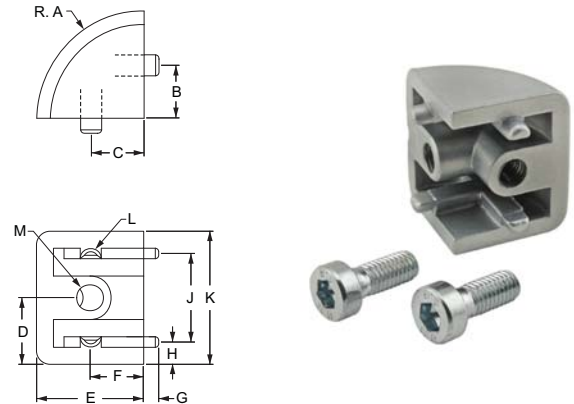

Dual Panel Holder

Part No.	Series	Type	A	B	C	D	E	F	G	H	J	K	L	M	N	P
4490	10 15	Single Panel	1.785"	.525"	.489	.978"	M4 hex	.350"	1.270"	.660"	.820"	.203"	.575"	.420"	.490"	5.00mm
65-4490	25 40	Single Panel	45.34mm	13.34mm	12.42mm	24.84mm	M4 hex	8.89mm	32.26mm	16.76mm	20.83mm	12.45mm	24.89mm	10.67mm	12.45mm	5.00mm
4491	10 15	Dual Panel	.790"	.390"	.390"	.490"	.790"	.395"	.110"	.164"	.653"	.980"	.078"	M5 tap	—	—
65-4491	25 40	Dual Panel	20.07mm	9.90mm	9.90mm	12.45mm	20.06mm	10.03mm	2.79mm	4.17mm	16.58mm	24.89mm	19.81mm	M5 tap	—	—

Material Specifications

Part No.	Material	Process	Finish	Weight
4490	Die Cast Zinc	Die Casting	Powder Coat	.169 lbs
65-4490				
4491				
65-4491				.085 lbs

Suggested Hardware (Mount Clamp to T-Slot)

Series	Part No.	Qty.	Bolt	Part No.	Qty.	T-Nut
10	3050	1	10-32 x 1/2" BHSCS	3205	1	10-32 Standard
15	3051	1	10-32 x 5/8" BHSCS	3201	1	10-32 Standard
25	11-5312	1	M5 x 12mm BHSCS	25-1954	1	M5 Standard
40	11-5314	1	M5 x 14mm BHSCS	13116	1	M5 Drop-in

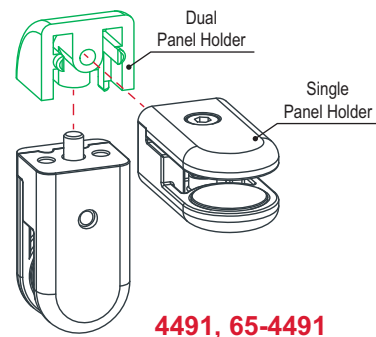
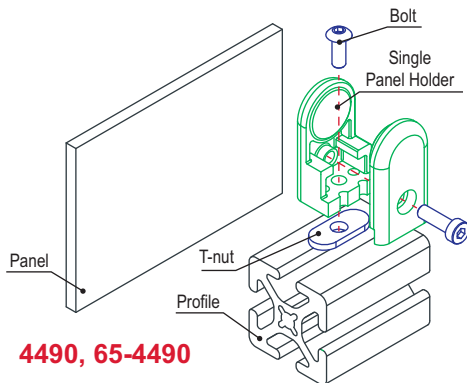

Part Description:

The snap on panel retainer snaps over the outside of square Quick Frame™ and 1010 profiles to hold .250" panels securely. It is commonly used in shelving and guarding applications. It comes in a stock length of 72.5 inches.

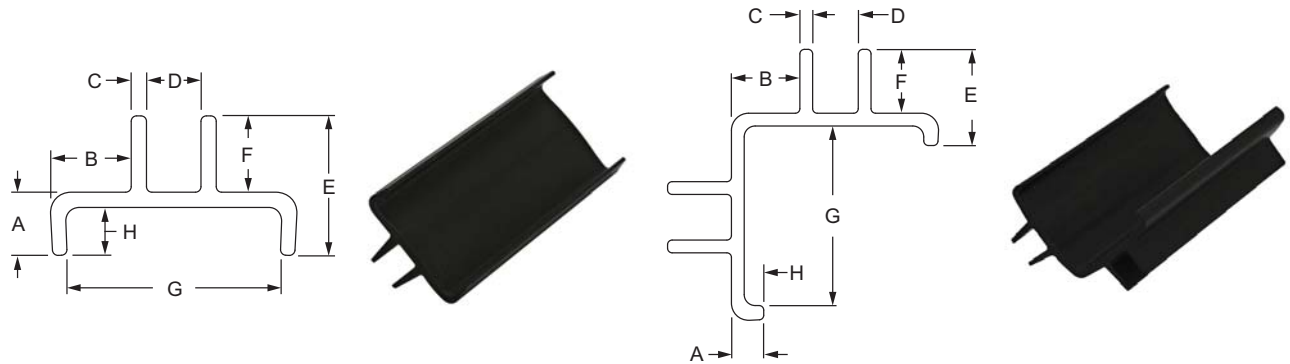

9355

9356

Part No.	Series	A	B	C	D	E	F	G	H	Weight
9355	10 QF	.290"	.370"	.070"	.250"	.640"	.350"	.980"	.220"	.540 lb
9356	QF	.177"	.370"	.070"	.250"	.527"	.350"	.984"	.107"	.868 lb

Material Specifications

Material	Process	Finish	Color
Plastic	Extruded	Matte	Black



Single Panel

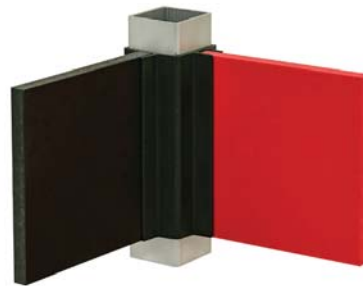

Double Panel

Roll-in Mesh Panel Retainer

Part Description:

The roll-in mesh panel retainer is used to mount a mesh panel when it is recessed within the T-slot. It rolls into the T-slot channel and can be used when the profile ends are closed, making assembly fast and easy. The self-threading screw is included and no machining services are required. **Important:** This retainer is not intended for use with expanded metal panels.

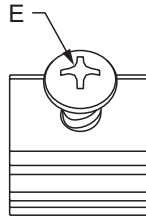
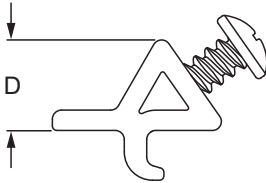
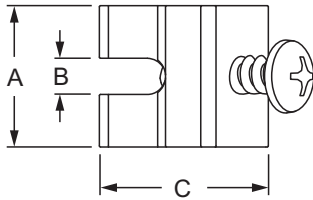

Part No.	Series	Material	Process	Color	A	B	C	D	E	Weight
2442	15 40	Nylon PA Glass Fiber Reinforced	Molded	Black	.625"	.160"	.747"	.400"	No. 2 Phillips	.006 lb

1

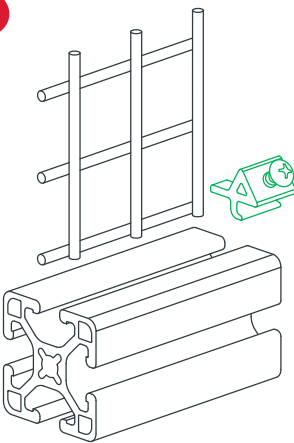

2

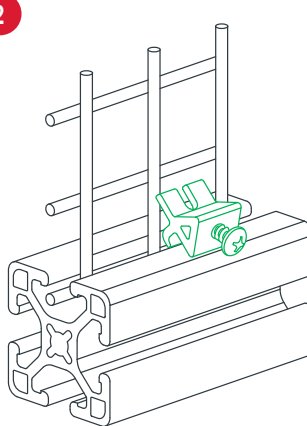

3

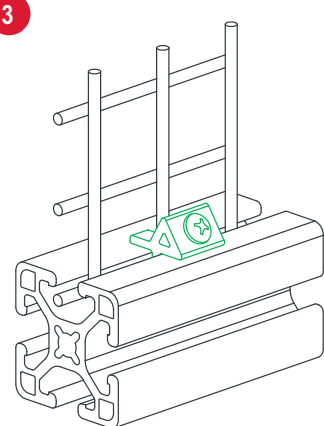

Part Description:

The straddle mesh retainer is typically used with Quick Frame™ profiles to secure 1.00" x 1.00" mesh panels. It straddles the wire and fastens to a square tube with self-tapping or self-drilling screws. There are options available in aluminum or gray plastic.

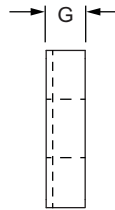
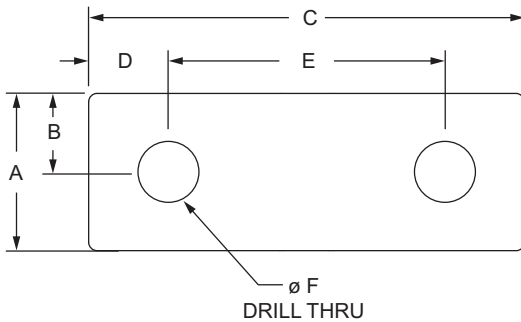

9310



9300



Part No.	Series	Material	Process	Finish	A	B	C	D	E	F	G	Weight
9300	QF	Aluminum	Machined	Mill Finish	.500"	.250"	1.750"	.313"	1.125"	.187"	.087"	.006 lb
9310	QF	Plastic	Molded	Matte Gray	.483"	.242"	1.340"	.245"	.850"	.180"	.120"	.002 lb

Suggested Hardware (Mount to QF Profile)

Part No.	Series	Qty.	Bolt
9301	QF	2	#8 x 5/8" Self Tapping Screw
9302	QF	2	#8 x 5/8" Self Drilling Screw

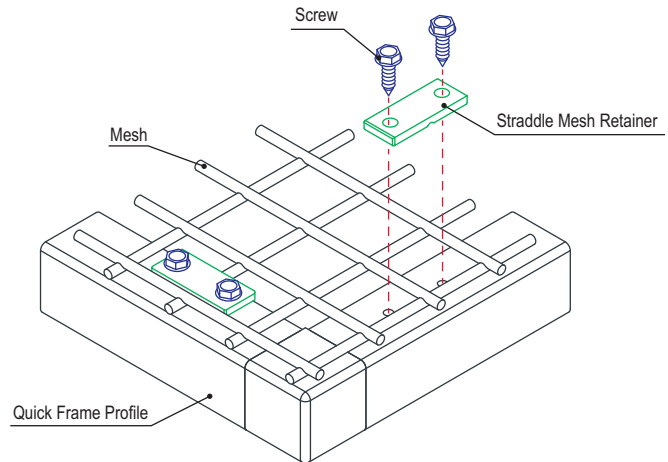

Wire Mesh Fastener

Part Description:

The wire mesh fastener is typically used with Quick Frame™ profiles to secure .500" x .500" mesh panels. It is made of gray nylon and fastens to a square tube with self-tapping or self-drilling screws. See below for suggested hardware.

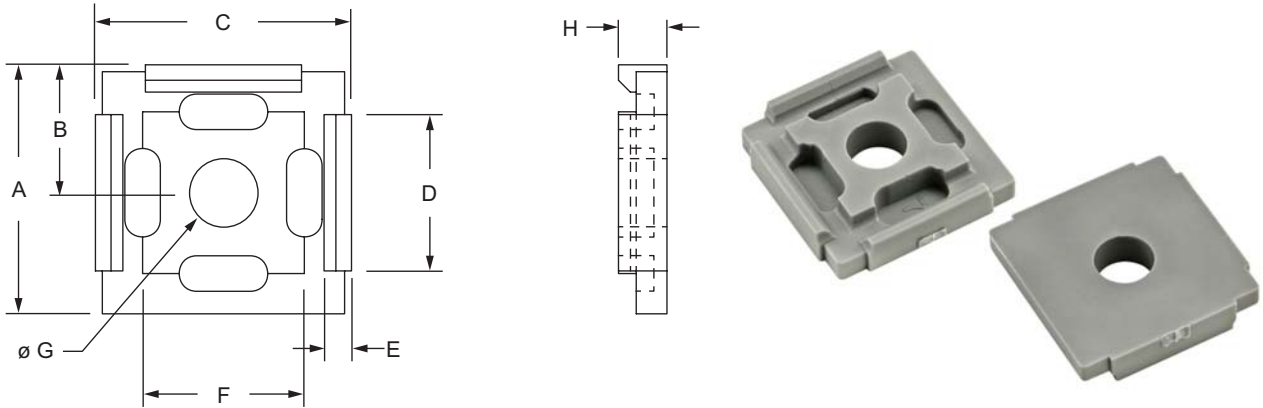

Part No.	Series	A	B	C	D	E	F	G	H	Weight
9305	QF	.632"	.325"	.649"	.396"	.070"	.410"	.172"	.123"	.001 lb

Material Specifications

Material	Process	Finish	Color
Nylon	Molded	Matte	Gray

Suggested Hardware (Mount to QF Profile)

Part No.	Series	Qty.	Bolt
9301	QF	1	#8 x 5/8" Self Tapping Screw
9302	QF	1	#8 x 5/8" Self Drilling Screw

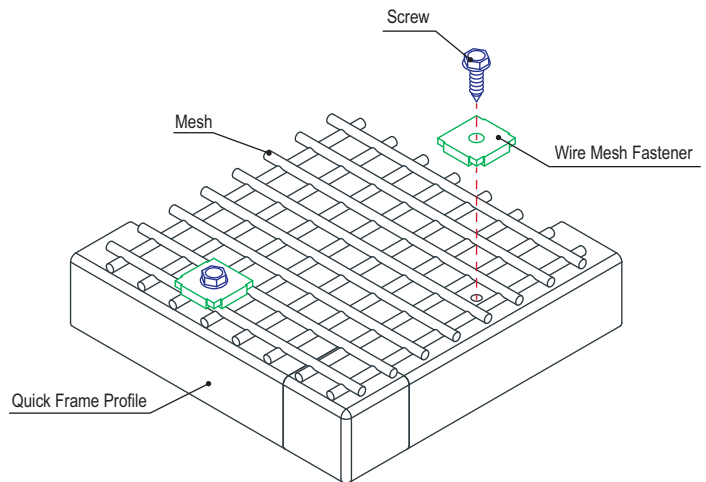

Part Description:

The economy sliding door glide is a cost-effective option that is used in access points to help profiles glide along the T-slot. It bolts onto the profile end and freely rotates as the door pivots. The economy sliding door glide is made of UHMW polyethylene and requires no lubrication. A stainless steel mounting screw is included. See page 528 for bi-fold door information.

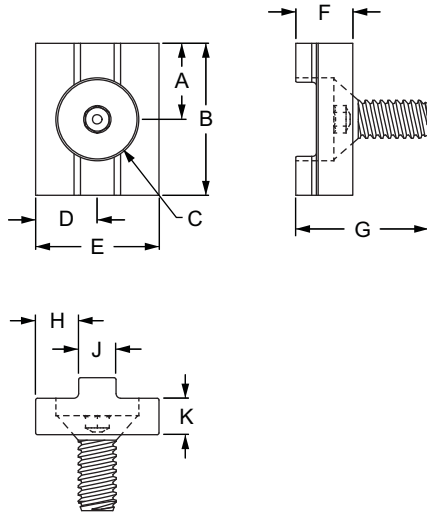

Part No.	Series	Pad Color	A	B	C	D	E	F	G	H	J	K	Weight
2067	10	Natural	.500"	1.000"	1/4-20 x .625	.406"	.812"	.375"	.875"	.283"	.246"	.240"	.009 lb
2068	15		.750"	1.500"	5/16-18 x .625	.625"	1.25"	.375"	.875"	.469"	.312"	.240"	.016 lb
25-2067	25	Black	12.50mm	25.00mm	M6-1.0 x 16mm	10.31mm	20.62mm	9.50mm	19.67mm	7.20mm	6.22mm	6.10mm	.0066 kg
40-2068	40		20.00mm	40.00mm	M8-1.25 x 16mm	15.88mm	31.75mm	9.53mm	22.35mm	7.92mm	11.91mm	6.10mm	.0142 kg

Material Specifications

Material	Grade	Process
UHMW	Virgin	Extruded

Required Machining Services

Machining Type	Machined	Reference Page
End Tap	Mounting Profile	853

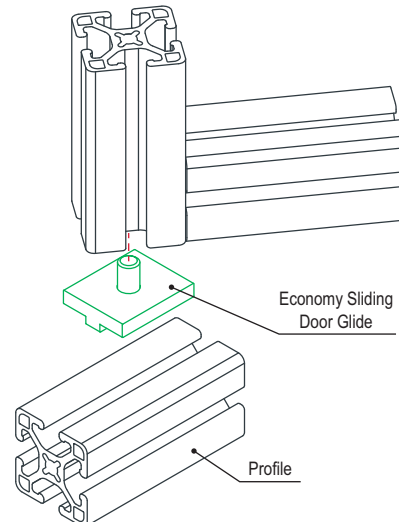

Standard Sliding Door Glide

Part Description:

The standard sliding door glide has a pad key that slides into a T-slot; it is commonly used to create a top rail sliding or bi-fold door. The standard sliding door glide bolts onto the profile end and freely rotates as the door pivots. It is made of UHMW polyethylene and requires no lubrication. A mounting screw is included. For information on machining services see page 853.

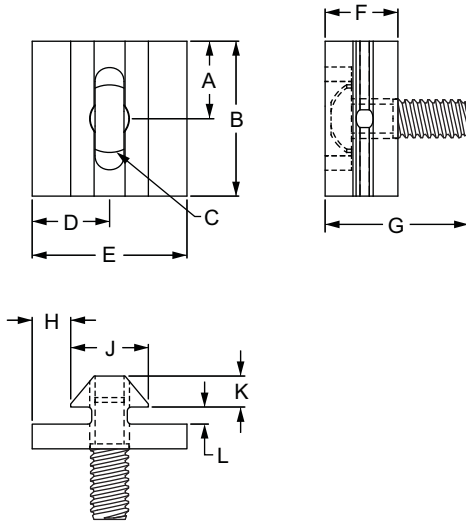

Part No.	Series	A	B	C	D	E	F	G	H	J	K	L	Weight
2059	10	.500"	1.000"	1/4-20	.500"	1.000"	.470"	.920"	.250"	.500"	.200"	.110"	.016 lb
2051	15	.750"	1.500"	5/16-18	.750"	1.500"	.700"	1.710"	.365"	.770"	.265"	.195"	.054 lb
25-2059	25	12.70mm	25.40mm	1/4-20	12.70mm	25.40mm	11.94mm	23.37mm	6.35mm	12.70mm	5.08mm	2.79mm	.0075 kg
40-2051	40	19.05mm	38.10mm	5/16-18	19.05mm	38.10mm	17.78mm	43.43mm	9.27mm	19.56mm	6.73mm	4.95mm	.0200 kg

Material Specifications

Material	Grade	Finish	Process
UHMW	Virgin	Natural	Extruded

Required Machining Services

Machining Type	Machined	Reference Page
End Tap	Mounting Profile	853

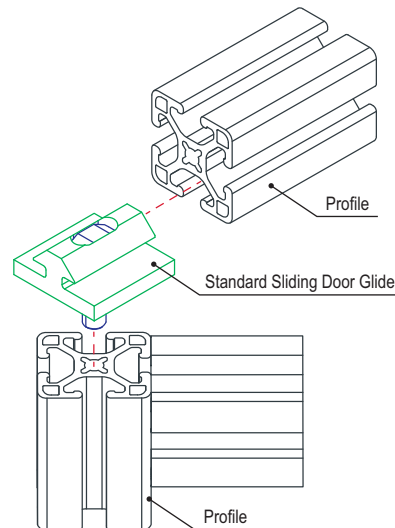

Part Description:

The standard sliding door glide profile has a pad key that slides into a T-slot; it is commonly used to create a top rail sliding or bi-fold door. It is ideal when used with the economy sliding door glide as a bottom mount. The standard sliding door glide bolts onto the profile end and freely rotates as the door pivots. It is made of UHMW polyethylene and requires no lubrication. The standard length of the glide profile is 145" (3.683M) or can be cut to length as a standard machining service (page 852).

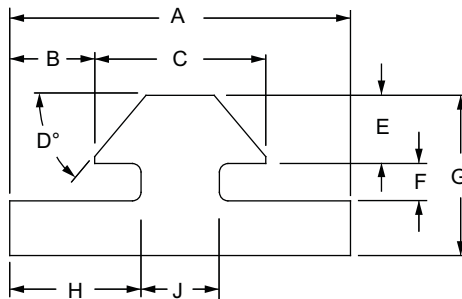

Part No.	Series	A	B	C	D	E	F	G	H	J	Length	Weight
6710	10	1.000"	.250"	.500"	50°	.200"	.110"	.470"	.385"	.230"	per inch	.008 lb / in.
6710-120	10	1.000"	.250"	.500"	50°	.200"	.110"	.470"	.385"	.230"	120.00"	1.020 lb
6710-145	10	1.000"	.250"	.500"	50°	.200"	.110"	.470"	.385"	.230"	145.00"	1.232 lb
6808	15	1.500"	.365"	.770"	45°	.265"	.195"	.700"	.600"	.300"	per inch	.018 lb / in.
6808-145	15	1.500"	.365"	.770"	45°	.265"	.195"	.700"	.600"	.300"	145.00"	2.711 lb
25-6710	25	25.40mm	6.35mm	12.70mm	50°	5.08mm	2.79mm	11.94mm	9.78mm	5.84mm	per millimeter	.0038 kg / mm
40-6808	40	38.10mm	9.27mm	19.56mm	45°	6.73mm	4.95mm	17.78mm	15.24mm	7.62mm	per millimeter	.0084 kg / mm
40-6808-3.683M	40	38.10mm	9.27mm	19.56mm	45°	6.73mm	4.95mm	17.78mm	15.24mm	7.62mm	3683.00mm	1.1698 kg

Material Specifications

Material	Grade	Finish	Process
UHMW	Virgin	Natural	Extruded

Required Machining Services

Machining Type	Machined	Reference Page
Cut to Length	Door Glide Profile	852

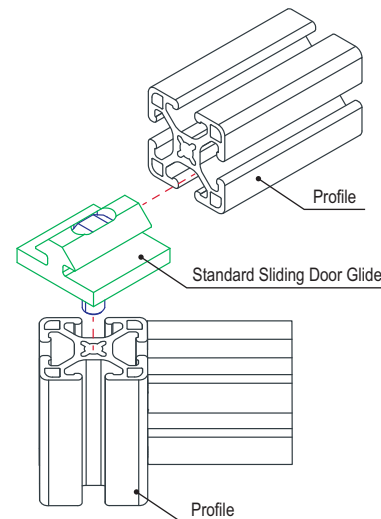

Upper & Lower Door Slide Track

Part Description:

The upper and lower door slide tracks snap into a T-slot with no required hardware. These tracks are used together to allow panels to be inserted after the frame is assembled. The lower slide track has a radius bearing surface that allows panels to slide easily. Both the upper and lower door slide tracks are 145" (3.683M) or can be cut to length with a standard machining service (page 852).

2211

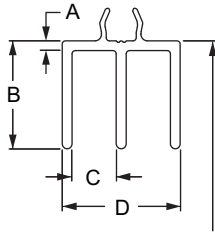

For panel height subtract .500" from overall height

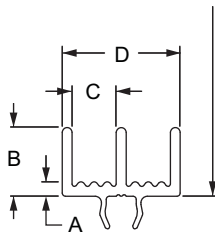

2221

2210

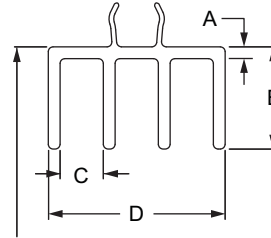

For panel height subtract .500" from overall height

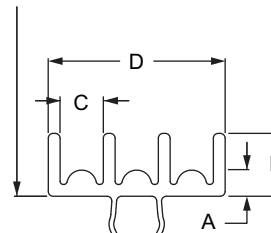

2220

Upper Door Slide Track

Part No.	Series	Material	Alloy*	Process	Finish	A	B	C	D	Length	Weight
2211	10	Aluminum	6105-T5	Extruded	Clear Anodize	.062"	.688"	.281"	.750"	per inch	.016 lb / in.
2211-48	10				Clear Anodize	.062"	.688"	.281"	.750"	48.000"	.778 lb
2211-145	10				Clear Anodize	.062"	.688"	.281"	.750"	145.000"	2.351 lb
2211-Black	10				Black Anodize	.062"	.688"	.281"	.750"	per inch	.016 lb / in.
2210	15				Clear Anodize	.075"	.650"	.275"	1.125"	per inch	.025 lb / in.
2210-48	15				Clear Anodize	.075"	.650"	.275"	1.125"	48.000"	1.217 lb
2210-145	15				Clear Anodize	.075"	.650"	.275"	1.125"	145.000"	3.677 lb
2210-Black	15				Black Anodize	.075"	.650"	.275"	1.125"	per inch	.025 lb / in.
25-2211	25				Clear Anodize	1.57mm	17.48mm	7.14mm	19.05mm	per millimeter	.0073 kg / mm
25-2211-3.68M	25				Clear Anodize	1.57mm	17.48mm	7.14mm	19.05mm	3.68M	1.0663 kg
25-2211-Black	25				Black Anodize	1.57mm	17.48mm	7.14mm	19.05mm	per millimeter	.0073 kg / mm
40-2210	40				Clear Anodize	1.91mm	16.51mm	6.99mm	28.58mm	per millimeter	.0115 kg / mm
40-2210-3.68M	40				Clear Anodize	1.91mm	16.51mm	6.99mm	28.58mm	3.68M	1.6678 kg
40-2210-Black	40				Black Anodize	1.91mm	16.51mm	6.99mm	28.58mm	per millimeter	.0115 kg / mm

* Or comparable

CONTINUE

Lower Door Slide Track

Part No.	Series	Material	Alloy*	Process	Finish	A	B	C	D	Length	Weight
2221	10	Aluminum	6105-T5	Extruded	Clear Anodize	.092"	.438"	.281"	.750"	per inch	.012 lb / in.
2221-48	10				Clear Anodize	.092"	.438"	.281"	.750"	48.000"	607 lb
2221-145	10				Clear Anodize	.092"	.438"	.281"	.750"	145.000"	1.833 lb
2221-Black	10				Black Anodize	.092"	.438"	.281"	.750"	per inch	.012 lb / in.
2220	15				Clear Anodize	.169"	.400"	.275"	1.125"	per inch	.022 lb / in.
2220-48	15				Clear Anodize	.169"	.400"	.275"	1.125"	48.000"	1.083 lb
2220-145	15				Clear Anodize	.169"	.400"	.275"	1.125"	145.000"	3.273 lb.
2220-Black	15				Black Anodize	.169"	.400"	.275"	1.125"	per inch	.0226 lb / in.
25-2221	25				Clear Anodize	2.34mm	11.13mm	7.14mm	19.05mm	per millimeter	.0057 kg / mm
25-2221-3.68M	25				Clear Anodize	2.34mm	11.13mm	7.14mm	19.05mm	3.68M	.8314 kg
25-2221-Black	25				Black Anodize	2.34mm	11.13mm	7.14mm	19.05mm	per millimeter	.0057 kg / mm
40-2220	40				Clear Anodize	4.29mm	10.16mm	6.99mm	28.58mm	per millimeter	.3969 kg / mm
40-2220-3.68M	40				Clear Anodize	4.29mm	10.16mm	6.99mm	28.58mm	3.68M	1.4846 kg
40-2220-Black	40				Black Anodize	4.29mm	10.16mm	6.99mm	28.58mm	per millimeter	.3969 kg / mm

* Or comparable

Required Machining Services

Machining Type	Machined	Reference Page
Cut to Length	Door Track Profile	852

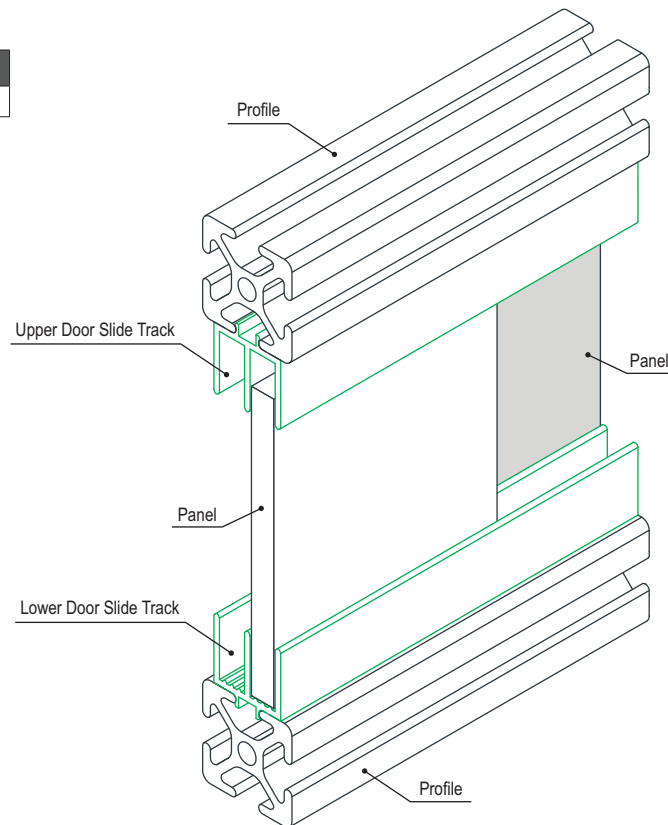

Roller Wheels

Roller Wheel with Ball Bearing Hub

The roller wheel with ball bearing hub is made of nylon and is reinforced with fiberglass. The ball bearing creates a smooth glide and is used to move frames, panels and components by rolling in the profile T-slot.

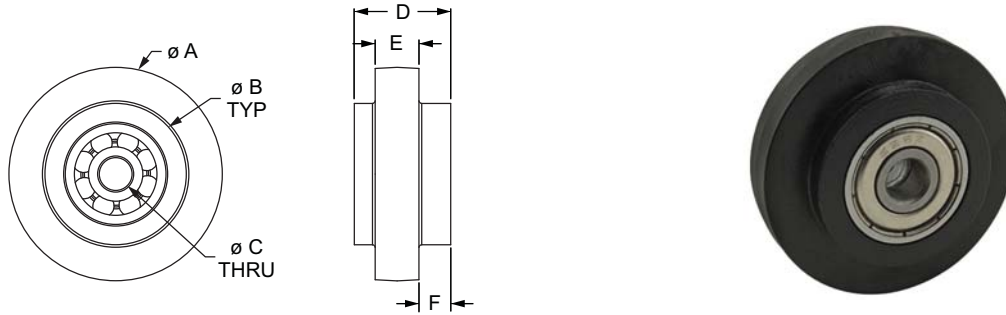

Part No.	Series	Material	Grade	Color	Process	A	B	C	D	E	F	Weight
12017	15 40	Nylon PA Glass Fiber Reinforced	PA6GK20	Black	Injection Molding	39.00mm	25.80mm	6.00mm	17.60mm	8.00mm	5.80mm	.0292 kg
12018	15 40					39.00mm	25.80mm	6.00mm	17.60mm	10.00mm	3.80mm	.0302 kg
12020	15 40					47.00mm	33.60mm	8.00mm	19.40mm	7.80mm	5.80mm	.0462 kg
12021	15 40					48.00mm	33.60mm	8.00mm	19.50mm	9.90mm	4.80mm	.0498 kg

Roller Wheel with Steel Hub

The roller wheel with steel hub is made of nylon and is reinforced with fiberglass. The steel hub creates a smooth glide and is used to move frames, panels and components by rolling in the profile T-slot.

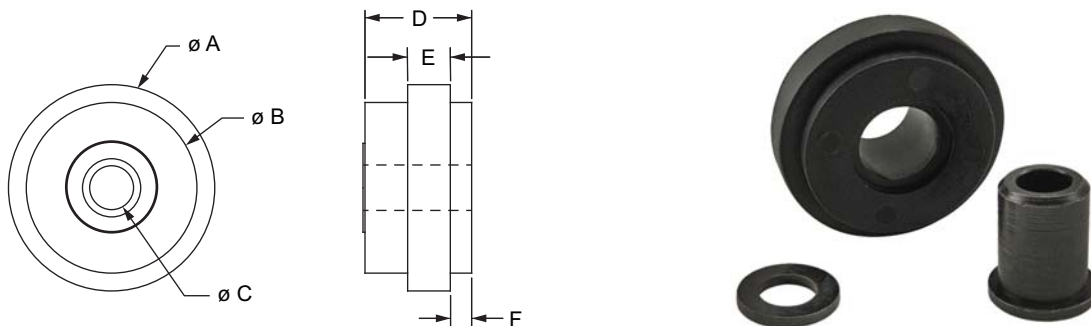

Part No.	Series	Material	Grade	Color	Process	A	B	C	D	E	F	Weight
12024	10 25	Nylon PA Glass Fiber Reinforced	PA6GK20	Black	Injection Molding	29.00mm	24.00mm	6.20mm	15.00mm	6.00mm	3.00mm	.036 lb

CONTINUE

Reinforced Roller Wheel

The roller wheel is made of nylon and is reinforced with fiberglass. The steel hub creates a smooth glide and it is used to move frames, panels and components by rolling in the profile T-slot. The mounting hardware is included.

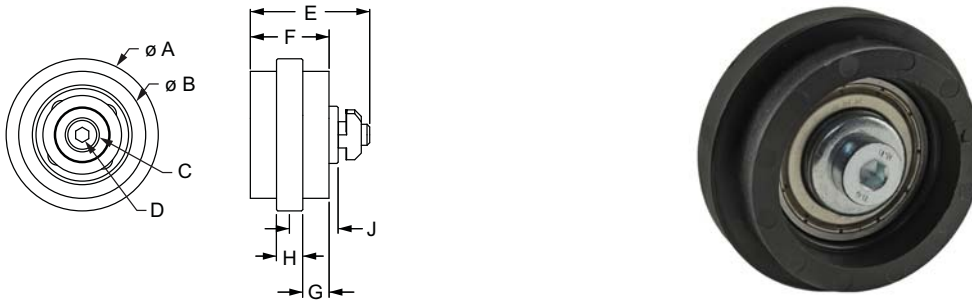

Part No.	Series	Material	Grade	Color	Process	A	B	C	D	E	F	G	H	J	Weight
12022	45	Nylon PA Glass Fiber Reinforced	PA6GK20	Black	Injection Molding	58.00mm	48.40mm	M8 x 45.00mm	M6	45.50mm	30.00mm	9.50mm	10.00mm	18.50mm	.1543 kg

Roller Wheel with Permanent Lubricated Bushing

The roller wheel with permanent lubricated bushing is ideal for guided linear motion and has a bronze bushing that requires no additional lubrication. The roller wheel mounts to the profile end or T-slot and includes the mounting hardware.

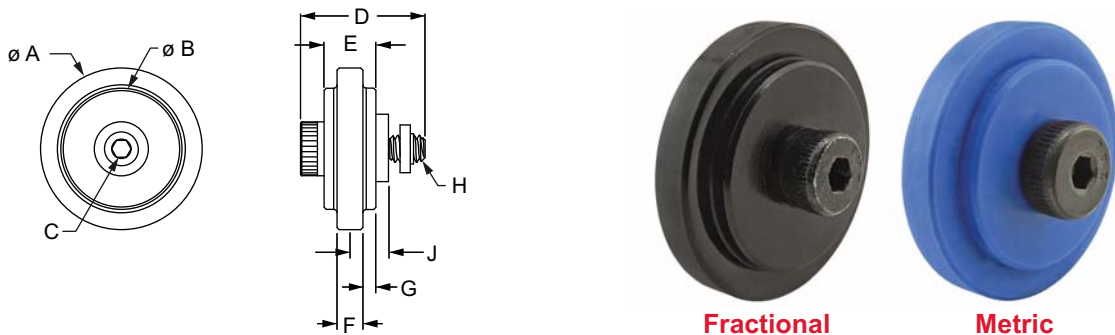

Part No.	Series	Material	Grade	Color	Process	A	B	C	D	E	F	G	H	J	Weight
2281	10 to 10	Nylon PA Glass Fiber Reinforced	K222-D	Black	Injection Molding	1.500"	1.125"	5/32	1.156"	.480"	.240"	.120"	1/4-20	.365"	.067 lb
2282	10 to 15					1.500"	1.125"	5/32	1.156"	.480"	.310"	.085"	1/4-20	.365"	.070 lb
2290	15 to 15					2.000"	1.625"	3/16	1.500"	.720"	.312"	.204"	5/16-18	.485"	.158 lb
25-2281	25 to 25			37.50mm		28.00mm	4.00mm	28.41mm	11.60mm	6.10mm	2.74mm	M6 x 1.0	8.97mm	.0318 kg	
65-2282	25 to 40			37.50mm		28.00mm	4.00mm	28.41mm	11.60mm	7.90mm	1.85mm	M6 x 1.0	8.97mm	.0621 kg	
40-2290	40 to 40			54.00mm		43.00mm	5.00mm	40.25mm	19.50mm	7.90mm	5.80mm	M8 x 1.25	12.92mm	.0849 kg	

CONTINUE

Roller Wheels (Continued)

Roller Wheel with Dual Roller Bearing

The roller wheel with dual roller bearing is made of nylon and is reinforced with fiberglass. The ball bearing creates a smooth glide and is used to move frames, panels and components by rolling in the profile T-slot. The mounting hardware is included.

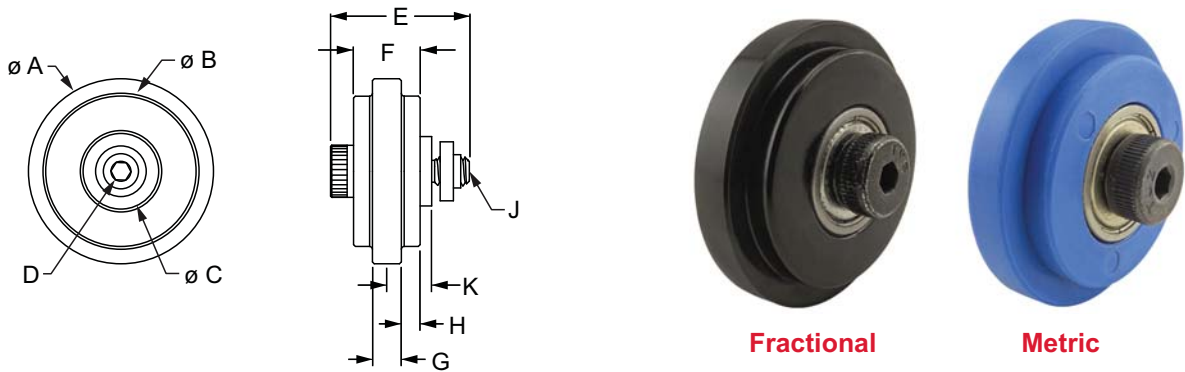

Part No.	Series	A	B	C	D	E	F	G	H	J	K	Weight
2280	15 to 15	2.000"	1.625"	.875"	3/16	1.495"	.720"	.312"	.204"	5/16-18	.485"	.181 lb
40-2280	40 to 40	54.00mm	43.00mm	26.00mm	5mm	40.25mm	19.48mm	7.90mm	5.79mm	M8 x 1.25	13.43mm	.1041 kg

Material Specifications

Part No.	Material	Grade	Color	Process
2073	Nylon PA Glass	K222-D	Black	Injection Molding
2073-Black	Fiber Reinforced		Blue	

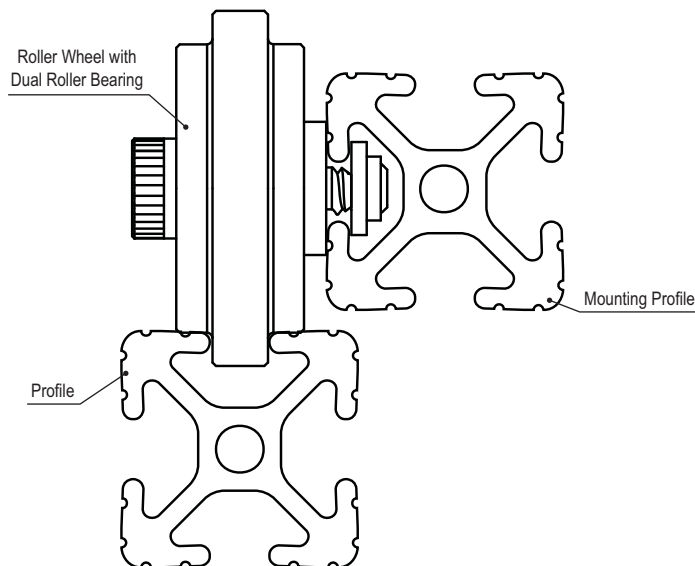

Part Description:

The dual roller wheel bracket is made of anodized aluminum and mounts to a T-slot profile. It is used with roller wheels to form assemblies that create door frames, linear glides, and track systems. The mounting hardware is included.

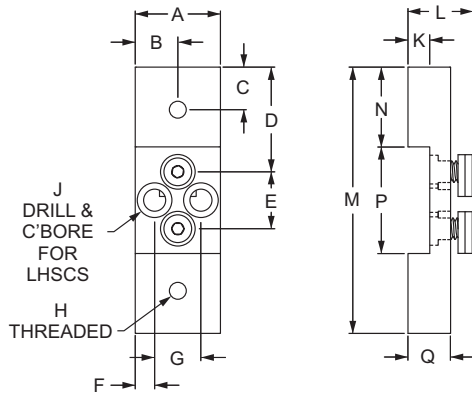

Part No.	Series	A	B	C	D	E	F	G	H	J	K	L	M	N	P	Q
2750	10	1.000"	.500"	.500"	1.228"	.669"	.228"	.544"	1/4-20	1/4-20	.255"	.765"	3.125"	.938"	1.250"	.500"
2750-Black	10	1.000"	.500"	.500"	1.228"	.669"	.228"	.544"	1/4-20	1/4-20	.255"	.765"	3.125"	.938"	1.250"	.500"
2752	10	1.000"	.500"	.500"	1.563"	1.000"	.228"	.544"	1/4-20	1/4-20	.255"	.765"	4.125"	.938"	2.250"	.500"
2752-Black	10	1.000"	.500"	.500"	1.563"	1.000"	.228"	.544"	1/4-20	1/4-20	.255"	.765"	4.125"	.938"	2.250"	.500"
2754	15	1.500"	.750"	.750"	1.883"	.860"	.383"	.735"	5/16-18	5/16-18	.390"	1.181"	4.625"	1.438"	1.750"	.750"
2754-Black	15	1.500"	.750"	.750"	1.883"	.860"	.383"	.735"	5/16-18	5/16-18	.390"	1.181"	4.625"	1.438"	1.750"	.750"
2757	15	1.500"	.750"	.750"	2.313"	1.500"	.382"	.735"	5/16-18	5/16-18	.390"	1.181"	6.125"	1.438"	3.250"	.750"
2757-Black	15	1.500"	.750"	.750"	2.313"	1.500"	.382"	.735"	5/16-18	5/16-18	.390"	1.181"	6.125"	1.438"	3.250"	.750"
25-2750	25	25.40mm	12.70mm	12.70mm	47.50mm	17.00mm	5.81mm	13.81mm	M6 x 1.0	M6 x 1.0	6.40mm	20.42mm	78.00mm	23.44mm	31.10mm	12.70mm
25-2750-Black	25	25.40mm	12.70mm	12.70mm	47.50mm	17.00mm	5.81mm	13.81mm	M6 x 1.0	M6 x 1.0	6.40mm	20.42mm	78.00mm	23.44mm	31.10mm	12.70mm
25-2752	25	25.40mm	12.70mm	12.70mm	38.80mm	25.40mm	5.81mm	13.81mm	M6 x 1.0	M6 x 1.0	6.40mm	20.42mm	103.00mm	23.44mm	56.10mm	12.70mm
25-2752-Black	25	25.40mm	12.70mm	12.70mm	38.80mm	25.40mm	5.81mm	13.81mm	M6 x 1.0	M6 x 1.0	6.40mm	20.42mm	103.00mm	23.44mm	56.10mm	12.70mm
40-2754	40	40.00mm	20.00mm	20.00mm	49.65mm	24.00mm	10.00mm	20.00mm	M8 x 1.25	M8 x 1.25	10.20mm	25.20mm	123.30mm	38.30mm	46.70mm	19.00mm
40-2754-Black	40	40.00mm	20.00mm	20.00mm	49.65mm	24.00mm	10.00mm	20.00mm	M8 x 1.25	M8 x 1.25	10.20mm	25.20mm	123.30mm	38.30mm	46.70mm	19.00mm
40-2757	40	40.00mm	20.00mm	20.00mm	61.65mm	40.00mm	10.00mm	20.00mm	M8 x 1.25	M8 x 1.25	10.20mm	31.20mm	163.30mm	38.30mm	86.70mm	19.00mm
40-2757-Black	40	40.00mm	20.00mm	20.00mm	61.65mm	40.00mm	10.00mm	20.00mm	M8 x 1.25	M8 x 1.25	10.20mm	31.20mm	163.30mm	38.30mm	86.70mm	19.00mm

Material Specifications	2750	2750-Black	2752	2752-Black	2754	2754-Black	2757	2757-Black	25-2750	25-2750-Black	25-2752	25-2752-Black	40-2754	40-2754-Black	40-2757	40-2757-Black
Weight	.138 lb		.162 lb		.458 lb		.534 lb		.0615 kg		.0715 kg		.2218 kg		.2608 kg	
Color	Clear	Black	Clear	Black	Clear	Black	Clear	Black	Clear	Black	Clear	Black	Clear	Black	Clear	Black
Material	Aluminum															
Alloy*	6105-T5															
Finish	Anodize															
Process	Milled															

* Or comparable

Dual Roller Wheel Bracket Assembly

Part Description:

The dual roller wheel bracket assembly mounts to a T-slot profile and includes one dual roller wheel bracket (page 517) and two roller wheels with permanent lubricated bushings or ball bearings (pages 515-516). The assembly is commonly used to create door frames, linear glides, or track systems. The mounting hardware is included.

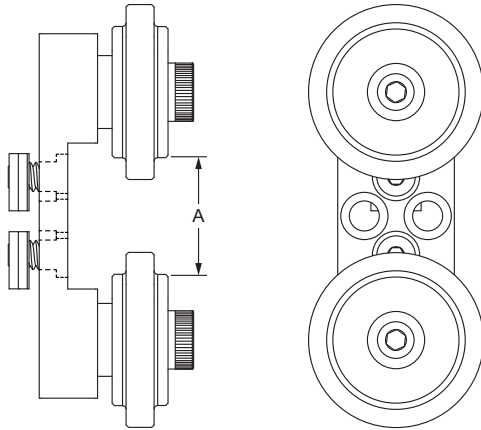

Fractional

Metric

Part No.	Series	Assembly Components		Included Hardware		Material	Process	Wheel Color	Bracket Color	A	Weight
		Bracket (Qty)	Wheel (Qty)	Bolt (Qty)	T-Nut (Qty)						
2751	10	2750 (1)	2281 (2)	275001 (2)	3204 (2)	Nylon PA Glass Fiber Reinforced K222-D	Injection Molding	Black	Clear Anodize	1.000"	.253 lb
2751-Black	10	2750 (1)	2281 (2)						Black Anodize	1.000"	.253 lb
2753	10	2752 (1)	2281 (2)						Clear Anodize	2.000"	.277 lb
2753-Black	10	2752 (1)	2281 (2)						Black Anodize	2.000"	.277 lb
2755	15	2754 (1)	2280 (2)	275401 (2)	3203 (2)				Clear Anodize	1.500"	.777 lb
2755-Black	15	2754 (1)	2280 (2)						Black Anodize	1.500"	.777 lb
2758	15	2757 (1)	2280 (2)						Clear Anodize	3.000"	.855 lb
2758-Black	15	2757 (1)	2280 (2)						Black Anodize	3.000"	.855 lb
2756	15	2754 (1)	2290 (2)						Clear Anodize	1.500"	.735 lb
2756-Black	15	2754 (1)	2290 (2)						Black Anodize	1.500"	.735 lb
2759	15	2757 (1)	2290 (2)					Clear Anodize	3.000"	.813 lb	
2759-Black	15	2757 (1)	2290 (2)					Black Anodize	3.000"	.813 lb	
25-2751	25	25-2750 (1)	25-2281 (2)	13-1993 (2)	3873 (2)			Clear Anodize	25.00mm	.1107 kg	
25-2751-Black	25	25-2750 (1)	25-2281 (2)					Black Anodize	25.00mm	.1107 kg	
25-2753	25	25-2752 (1)	25-2281 (2)					Clear Anodize	50.00mm	.1274 kg	
25-2753-Black	25	25-2752 (1)	25-2281 (2)	Black Anodize	50.00mm			.1274 kg			
40-2755	40	40-2754 (1)	40-2280 (2)	13-1957 (2)	3868 (2)			Clear Anodize	40.00mm	.4129 kg	
40-2755-Black	40	40-2754 (1)	40-2280 (2)					Black Anodize	40.00mm	.4129 kg	
40-2758	40	40-2757 (1)	40-2280 (2)					Clear Anodize	80.00mm	.4519 kg	
40-2758-Black	40	40-2757 (1)	40-2280 (2)					Black Anodize	80.00mm	.4519 kg	
40-2756	40	40-2754 (1)	40-2290 (2)			Clear Anodize	40.00mm	.3747 kg			
40-2756-Black	40	40-2754 (1)	40-2290 (2)			Black Anodize	40.00mm	.3747 kg			
40-2759	40	40-2757 (1)	40-2290 (2)			Clear Anodize	80.00mm	.4122 kg			
40-2759-Black	40	40-2757 (1)	40-2290 (2)			Black Anodize	80.00mm	.4122 kg			

Standard Lift-Off Hinge - Right Hand with Single Long Pin

Part Description:

The standard lift-off hinge – right hand with single long pin is made of anodized aluminum. The heavy-duty stainless steel hinge pin provides a smooth, long-lasting, strong connection. The captivated nylon thrust washer eliminates metal-to-metal contact and won't fall out. When the long pin is placed in the upper position it simplifies door assembly. Hinges with long pins are commonly used to create lift-off hinge assemblies (pages 525-527 for assembly options). The mounting hardware is included.

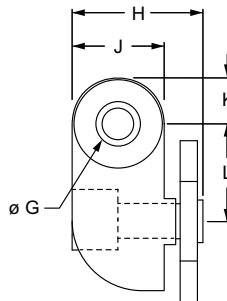
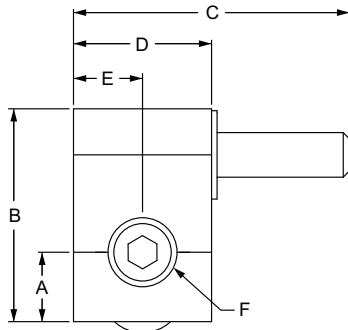

Part No.	Series	A	B	C	D	E	F	G	H	J	K	L	Weight
2073	10	.377"	1.156"	1.500"	.750"	.375"	10-32	.242"	.750"	.500"	.250"	.529"	.060 lb
2073-Black	10	.377"	1.156"	1.500"	.750"	.375"	10-32	.242"	.750"	.500"	.250"	.529"	.060 lb
2093	15	.625"	1.655"	1.500"	.750"	.375"	1/4-20	.242"	.875"	.500"	.250"	.780"	.086 lb
2093-Black	15	.625"	1.655"	1.500"	.750"	.375"	1/4-20	.242"	.875"	.500"	.250"	.780"	.086 lb
25-2073	25	9.40mm	29.00mm	38.05mm	19.05mm	9.53mm	M5 x 0.8	6.15mm	18.90mm	13.00mm	6.20mm	13.40mm	.0262 kg
25-2073-Black	25	9.40mm	29.00mm	38.05mm	19.05mm	9.53mm	M5 x 0.8	6.15mm	18.90mm	13.00mm	6.20mm	13.40mm	.0262 kg
40-2093	40	16.85mm	43.60mm	38.05mm	19.05mm	9.53mm	M6 x 1.0	6.15mm	18.90mm	13.00mm	6.12mm	20.70mm	.0436 kg
40-2093-Black	40	16.85mm	43.60mm	38.05mm	19.05mm	9.53mm	M6 x 1.0	6.15mm	18.90mm	13.00mm	6.12mm	20.70mm	.0436 kg

*The gap distance between the two mating profiles is .063" (1.60mm)

Material Specifications

Part No.	Material	Alloy*	Process	Finish
2073	Aluminum	6105-T5	Milled	Clear Anodize
2073-Black				Black Anodize
2093				Clear Anodize
2093-Black				Black Anodize
25-2073				Clear Anodize
25-2073-Black				Black Anodize
40-2093				Clear Anodize
40-2093-Black				Black Anodize

* Or comparable

Included Hardware (Mount to T-Slot)

Series	Part No.	Qty.	Bolt	Part No.	Qty.	T-Nut
10	3048	1	10-32 x 1/2" SHCS (Black)	3276	1	Economy
15	3067	1	1/4-20 x 5/8" SHCS (Black)	3286	1	Economy
25	13-5512	1	M5 x 12mm SHCS (Blue)	25-1951	1	Economy
40	13-6516	1	M6 x 16mm SHCS (Blue)	3836	1	Economy

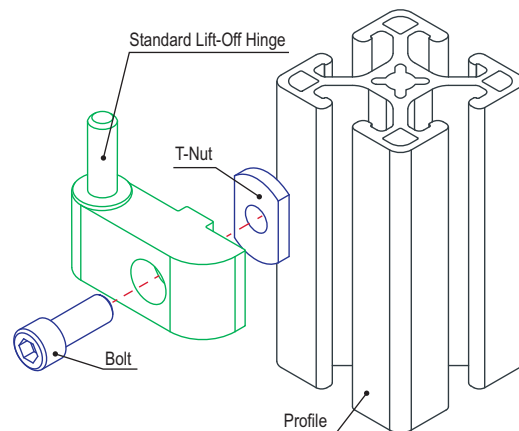

Standard Lift-Off Hinge - Right Hand with Single Short Pin

Part Description:

The standard lift-off hinge – right hand with single short pin is made of anodized aluminum. The heavy-duty stainless steel hinge pin provides a smooth, long-lasting, strong connection. The captivated nylon thrust washer eliminates metal-to-metal contact and won't fall out. Hinges with short pins are commonly used to create captivated assemblies (pages 525-527 for assembly options). The mounting hardware is included.

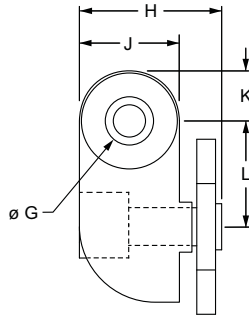
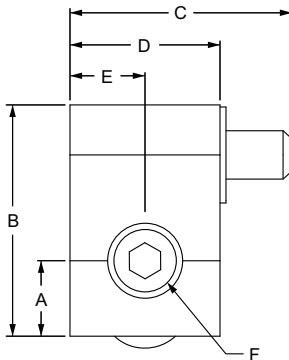

Part No.	Series	A	B	C	D	E	F	G	H	J	K	L	Weight
2075	10	.377"	1.156"	1.110"	.750"	.375"	10-32	.242"	.750"	.500"	.250"	.529"	.055 lb
2075-Black	10	.377"	1.156"	1.110"	.750"	.375"	10-32	.242"	.750"	.500"	.250"	.529"	.055 lb
2095	15	.625"	1.655"	1.110"	.750"	.375"	1/4-20	.242"	.875"	.500"	.250"	.780"	.082 lb
2095-Black	15	.625"	1.655"	1.110"	.750"	.375"	1/4-20	.242"	.875"	.500"	.250"	.780"	.082 lb
25-2075	25	9.40mm	29.00mm	28.15mm	19.05mm	9.53mm	M5 x 0.8	6.15mm	18.90mm	13.00mm	6.20mm	13.40mm	.0238 kg
25-2075-Black	25	9.40mm	29.00mm	28.15mm	19.05mm	9.53mm	M5 x 0.8	6.15mm	18.90mm	13.00mm	6.20mm	13.40mm	.0238 kg
40-2095	40	16.85mm	43.60mm	28.15mm	19.05mm	9.53mm	M6 x 1.0	6.15mm	18.90mm	13.00mm	6.12mm	20.70mm	.0415 kg
40-2095-Black	40	16.85mm	43.60mm	28.15mm	19.05mm	9.53mm	M6 x 1.0	6.15mm	18.90mm	13.00mm	6.12mm	20.70mm	.0415 kg

*The gap distance between the two mating profiles is .063" (1.60mm)

Material Specifications

Part No.	Material	Alloy*	Process	Finish
2075	Aluminum	6105-T5	Milled	Clear Anodize
2075-Black				Black Anodize
2095				Clear Anodize
2095-Black				Black Anodize
25-2075				Clear Anodize
25-2075-Black				Black Anodize
40-2095				Clear Anodize
40-2095-Black				Black Anodize

* Or comparable

Included Hardware (Mount to T-Slot)

Series	Part No.	Qty.	Bolt	Part No.	Qty.	T-Nut
10	3048	1	10-32 x 1/2" SHCS (Black)	3276	1	Economy
15	3067	1	1/4-20 x 5/8" SHCS (Black)	3286	1	Economy
25	13-5512	1	M5 x 12mm SHCS (Blue)	25-1951	1	Economy
40	13-6516	1	M6 x 16mm SHCS (Blue)	3836	1	Economy

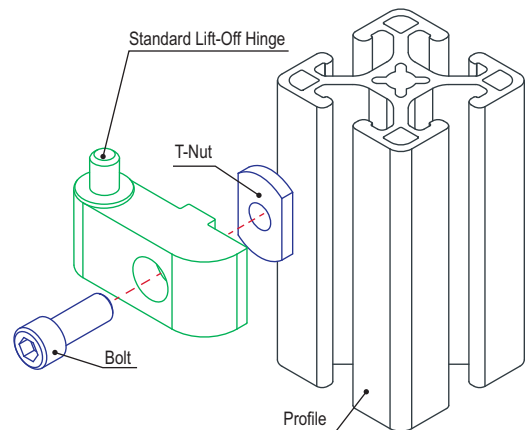

Standard Lift-Off Hinge - Left Hand with Single Long Pin

Part Description:

The standard lift-off hinge – left hand with single long pin is made of anodized aluminum. The heavy-duty stainless steel hinge pin provides a smooth, long-lasting, strong connection. The captivated nylon thrust washer eliminates metal-to-metal contact and won't fall out. When the long pin is placed in the upper position it simplifies door assembly. Hinges with long pins are commonly used to create lift-off assemblies (pages 525-527). The mounting hardware is included.

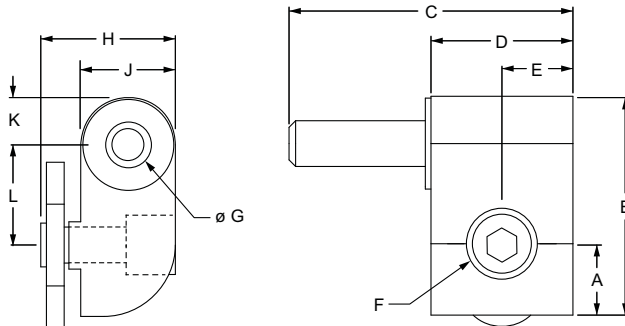

Part No.	Series	A	B	C	D	E	F	G	H	J	K	L	Weight
2074	10	.377"	1.156"	1.500"	.750"	.375"	10-32	.242"	.750"	.500"	.250"	.529"	.060 lb
2074-Black	10	.377"	1.156"	1.500"	.750"	.375"	10-32	.242"	.750"	.500"	.250"	.529"	.060 lb
2094	15	.625"	1.655"	1.500"	.750"	.375"	1/4-20	.242"	.875"	.500"	.250"	.780"	.087 lb
2094-Black	15	.625"	1.655"	1.500"	.750"	.375"	1/4-20	.242"	.875"	.500"	.250"	.780"	.087 lb
25-2074	25	9.40mm	29.00mm	38.05mm	19.05mm	9.53mm	M5 x 0.8	6.15mm	18.90mm	13.00mm	6.20mm	13.40mm	.0267 kg
25-2074-Black	25	9.40mm	29.00mm	38.05mm	19.05mm	9.53mm	M5 x 0.8	6.15mm	18.90mm	13.00mm	6.20mm	13.40mm	.0267 kg
40-2094	40	16.85mm	43.60mm	38.05mm	19.05mm	9.53mm	M6 x 1.0	6.15mm	18.90mm	13.00mm	6.12mm	20.70mm	.0436 kg
40-2094-Black	40	16.85mm	43.60mm	38.05mm	19.05mm	9.53mm	M6 x 1.0	6.15mm	18.90mm	13.00mm	6.12mm	20.70mm	.0436 kg

*The gap distance between the two mating profiles is .063" (1.60mm)

Material Specifications

Part No.	Material	Alloy*	Process	Finish
2074	Aluminum	6105-T5	Milled	Clear Anodize
2074-Black				Black Anodize
2094				Clear Anodize
2094-Black				Black Anodize
25-2074				Clear Anodize
25-2074-Black				Black Anodize
40-2094				Clear Anodize
40-2094-Black				Black Anodize

* Or comparable

Included Hardware (Mount to T-Slot)

Series	Part No.	Qty.	Bolt	Part No.	Qty.	T-Nut
10	3048	1	10-32 x 1/2" SHCS (Black)	3276	1	Economy
15	3067	1	1/4-20 x 5/8" SHCS (Black)	3286	1	Economy
25	13-5512	1	M5 x 12mm SHCS (Blue)	25-1951	1	Economy
40	13-6516	1	M6 x 16mm SHCS (Blue)	3836	1	Economy

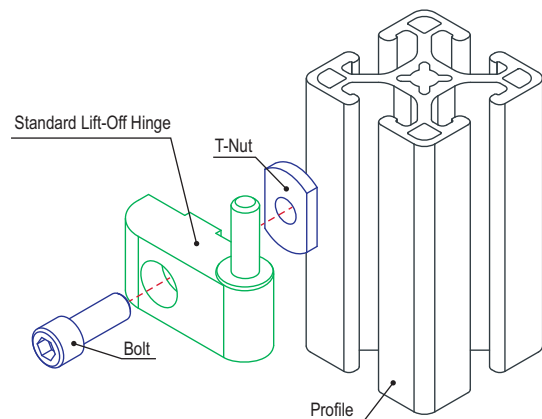

Standard Lift-Off Hinge - Left Hand with Single Short Pin

Part Description:

The standard lift-off hinge – left hand with single short pin is made of anodized aluminum. The heavy-duty stainless steel hinge pin provides a smooth, long-lasting, strong connection. The captivated nylon thrust washer eliminates metal-to-metal contact and won't fall out. Hinges with short pins are commonly used to create captivated assemblies (pages 525-527). The mounting hardware is included.

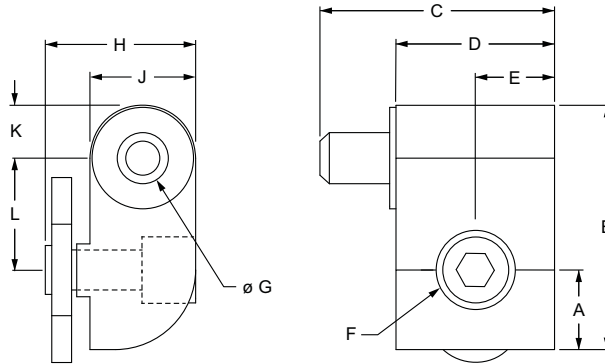

Part No.	Series	A	B	C	D	E	F	G	H	J	K	L	Weight
2076	10	.377"	1.156"	1.110"	.750"	.375"	10-32	.242"	.750"	.500"	.250"	.529"	.055 lb
2076-Black	10	.377"	1.156"	1.110"	.750"	.375"	10-32	.242"	.750"	.500"	.250"	.529"	.055 lb
2096	15	.625"	1.655"	1.110"	.750"	.375"	1/4-20	.242"	.875"	.500"	.250"	.780"	.082 lb
2096-Black	15	.625"	1.655"	1.110"	.750"	.375"	1/4-20	.242"	.875"	.500"	.250"	.780"	.082 lb
25-2076	25	9.40mm	29.00mm	28.15mm	19.05mm	9.53mm	M5 x 0.8	6.15mm	18.90mm	13.00mm	6.20mm	13.40mm	.0241 kg
25-2076-Black	25	9.40mm	29.00mm	28.15mm	19.05mm	9.53mm	M5 x 0.8	6.15mm	18.90mm	13.00mm	6.20mm	13.40mm	.0241 kg
40-2096	40	16.85mm	43.60mm	28.15mm	19.05mm	9.53mm	M6 x 1.0	6.15mm	18.90mm	13.00mm	6.12mm	20.70mm	.0413 kg
40-2096-Black	40	16.85mm	43.60mm	28.15mm	19.05mm	9.53mm	M6 x 1.0	6.15mm	18.90mm	13.00mm	6.12mm	20.70mm	.0413 kg

*The gap distance between the two mating profiles is .063" (1.60mm)

Material Specifications

Part No.	Material	Alloy*	Process	Finish
2076	Aluminum	6105-T5	Milled	Clear Anodize
2076-Black				Black Anodize
2096				Clear Anodize
2096-Black				Black Anodize
25-2076				Clear Anodize
25-2076-Black				Black Anodize
40-2096				Clear Anodize
40-2096-Black				Black Anodize

* Or comparable

Included Hardware (Mount to T-Slot)

Series	Part No.	Qty.	Bolt	Part No.	Qty.	T-Nut
10	3048	1	10-32 x 1/2" SHCS (Black)	3276	1	Economy
15	3067	1	1/4-20 x 5/8" SHCS (Black)	3286	1	Economy
25	13-5512	1	M5 x 12mm SHCS (Blue)	25-1951	1	Economy
40	13-6516	1	M6 x 16mm SHCS (Blue)	3836	1	Economy

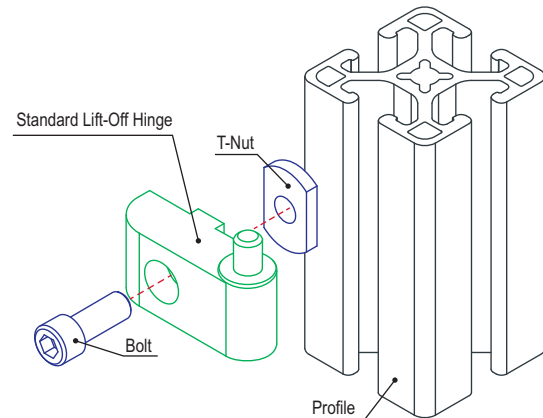

Part Description:

The standard lift-off hinge – mating hub is made of anodized aluminum. Use with lift-off hinges to create assemblies (see pages 525-527 for assembly options). The standard lift-off hinge with mating hub should not be used to connect two long pin hubs. The mounting hardware is included.

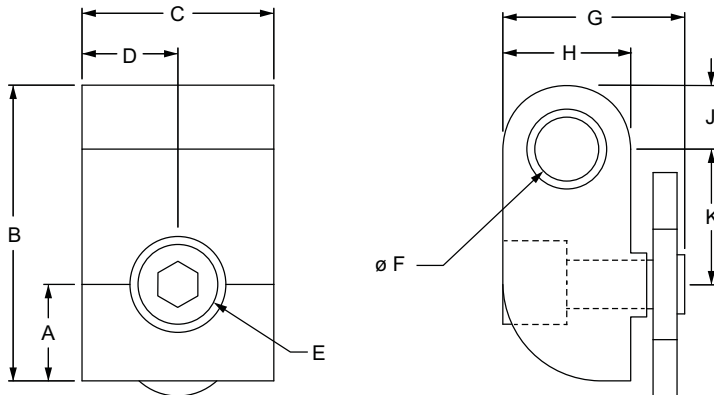

Part No.	Series	A	B	C	D	E	F	G	H	J	K	Weight
2077	10	.377"	1.156"	.750"	.375"	10-32	.250"	.750"	.500"	.250"	.529"	.049 lb
2077-Black	10	.377"	1.156"	.750"	.375"	10-32	.250"	.750"	.500"	.250"	.529"	.049 lb
2097	15	.625"	1.655"	.750"	.375"	1/4-20	.250"	.875"	.500"	.250"	.780"	.076 lb
2097-Black	15	.625"	1.655"	.750"	.375"	1/4-20	.250"	.875"	.500"	.250"	.780"	.076 lb
25-2077	25	9.40mm	29.00mm	19.05mm	9.53mm	M5 x 0.8	6.15mm	18.90mm	13.00mm	6.20mm	13.40mm	.0213 kg
25-2077-Black	25	9.40mm	29.00mm	19.05mm	9.53mm	M5 x 0.8	6.15mm	18.90mm	13.00mm	6.20mm	13.40mm	.0213 kg
40-2097	40	16.85mm	43.60mm	19.05mm	9.53mm	M6 x 1.0	6.15mm	18.90mm	13.00mm	6.12mm	20.70mm	.0386 kg
40-2097-Black	40	16.85mm	43.60mm	19.05mm	9.53mm	M6 x 1.0	6.15mm	18.90mm	13.00mm	6.12mm	20.70mm	.0386 kg

*The gap distance between the two mating profiles is .063" (1.60mm)

Material Specifications

Part No.	Material	Alloy*	Process	Finish
2077	Aluminum	6105-T5	Milled	Clear Anodize
2077-Black				Black Anodize
2097				Clear Anodize
2097-Black				Black Anodize
25-2077				Clear Anodize
25-2077-Black				Black Anodize
40-2097				Clear Anodize
40-2097-Black				Black Anodize

* Or comparable

Included Hardware (Mount to T-Slot)

Series	Part No.	Qty.	Bolt	Part No.	Qty.	T-Nut
10	3048	1	10-32 x 1/2" SHCS (Black)	3276	1	Economy
15	3067	1	1/4-20 x 5/8" SHCS (Black)	3286	1	Economy
25	13-5512	1	M5 x 12mm SHCS (Blue)	25-1951	1	Economy
40	13-6516	1	M6 x 16mm SHCS (Blue)	3836	1	Economy

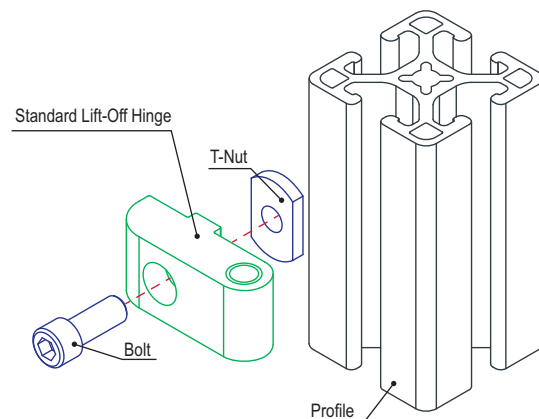

Standard Lift-Off Hinge with Double Short Pins

Part Description:

The standard lift-off hinge with double short pins is made of anodized aluminum. The heavy-duty stainless steel hinge pins provide a smooth, long-lasting, strong connection. The captivated nylon thrust washers eliminate metal-to-metal contact and won't fall out. The standard lift-off hinge with double short pins is commonly used with two standard lift-off hinge mating hubs to create a captivated assembly. The mounting hardware is included.

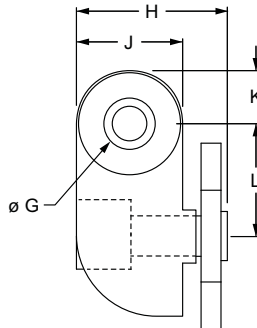
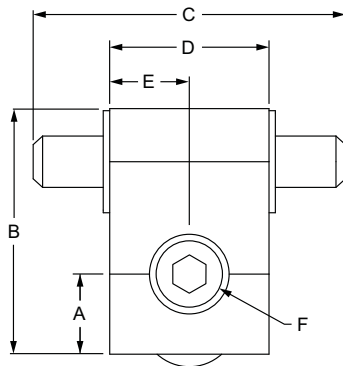

Part No.	Series	A	B	C	D	E	F	G	H	J	K	L	Weight
2078	10	.377"	1.156"	1.470"	.750"	.375"	10-32	.242"	.750"	.500"	.250"	.529"	.063 lb
2078-Black	10	.377"	1.156"	1.470"	.750"	.375"	10-32	.242"	.750"	.500"	.250"	.529"	.063 lb
2098	15	.625"	1.655"	1.470"	.750"	.375"	1/4-20	.242"	.875"	.500"	.250"	.780"	.089 lb
2098-Black	15	.625"	1.655"	1.470"	.750"	.375"	1/4-20	.242"	.875"	.500"	.250"	.780"	.089 lb
25-2078	25	9.40mm	29.00mm	37.30mm	19.05mm	9.53mm	M5 x 0.8	6.15mm	18.90mm	13.00mm	6.20mm	13.40mm	.0277 kg
25-2078-Black	25	9.40mm	29.00mm	37.30mm	19.05mm	9.53mm	M5 x 0.8	6.15mm	18.90mm	13.00mm	6.20mm	13.40mm	.0277 kg
40-2098	40	16.85mm	43.60mm	37.30mm	19.05mm	9.53mm	M6 x 1.0	6.15mm	18.90mm	13.00mm	6.12mm	20.70mm	.0448 kg
40-2098-Black	40	16.85mm	43.60mm	37.30mm	19.05mm	9.53mm	M6 x 1.0	6.15mm	18.90mm	13.00mm	6.12mm	20.70mm	.0448 kg

*The gap distance between the two mating profiles is .063" (1.60mm)

Material Specifications

Part No.	Material	Alloy*	Process	Finish
2078	Aluminum	6105-T5	Milled	Clear Anodize
2078-Black				Black Anodize
2098				Clear Anodize
2098-Black				Black Anodize
25-2078				Clear Anodize
25-2078-Black				Black Anodize
40-2098				Clear Anodize
40-2098-Black				Black Anodize

* Or comparable

Included Hardware (Mount to T-Slot)

Series	Part No.	Qty.	Bolt	Part No.	Qty.	T-Nut
10	3048	1	10-32 x 1/2" SHCS (Black)	3276	1	Economy
15	3067	1	1/4-20 x 5/8" SHCS (Black)	3286	1	Economy
25	13-5512	1	M5 x 12mm SHCS (Blue)	25-1951	1	Economy
40	13-6516	1	M6 x 16mm SHCS (Blue)	3836	1	Economy

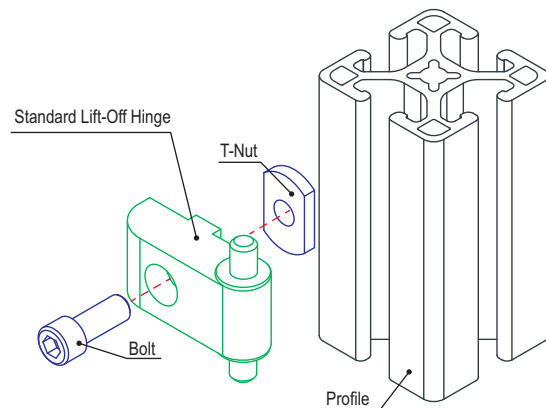

Part Description:

The standard lift-off hinge - right hand assembly is comprised of one standard lift-off hinge - right hand with single long pin, one standard lift-off hinge - right hand with single short pin and two standard lift-off hinge - mating hubs.

Part No.	Series	Assembly Components			Finish	Weight	Product Representation
2064	10	2073 Right Hand with Single Long Pin (Qty. 1)	2075 Right Hand with Single Short Pin (Qty. 1)	2077 Mating Hub (Qty. 2)	Clear Anodize	.214 lb	
2064-Black	10	2073 Right Hand with Single Long Pin (Qty. 1)	2075 Right Hand with Single Short Pin (Qty. 1)	2077 Mating Hub (Qty. 2)	Black Anodize	.214 lb	
2104	15	2093 Right Hand with Single Long Pin (Qty. 1)	2095 Right Hand with Single Short Pin (Qty. 1)	2097 Mating Hub (Qty. 2)	Clear Anodize	.322 lb	
2104-Black	15	2093 Right Hand with Single Long Pin (Qty. 1)	2095 Right Hand with Single Short Pin (Qty. 1)	2097 Mating Hub (Qty. 2)	Black Anodize	.322 lb	
2101	10 to 15	2093 Right Hand with Single Long Pin (Qty. 1)	2095 Right Hand with Single Short Pin (Qty. 1)	2077 Mating Hub (Qty. 2)	Clear Anodize	.262 lb	
2101-Black	10 to 15	2093 Right Hand with Single Long Pin (Qty. 1)	2095 Right Hand with Single Short Pin (Qty. 1)	2077 Mating Hub (Qty. 2)	Black Anodize	.262 lb	
25-2064	25	25-2073 Right Hand with Single Long Pin (Qty. 1)	25-2075 Right Hand with Single Short Pin (Qty. 1)	25-2077 Mating Hub (Qty. 2)	Clear Anodize	.0934 kg	
25-2064-Black	25	25-2073 Right Hand with Single Long Pin (Qty. 1)	25-2075 Right Hand with Single Short Pin (Qty. 1)	25-2077 Mating Hub (Qty. 2)	Black Anodize	.0934 kg	
40-2104	40	40-2093 Right Hand with Single Long Pin (Qty. 1)	40-2095 Right Hand with Single Short Pin (Qty. 1)	40-2097 Mating Hub (Qty. 2)	Clear Anodize	.1633 kg	
40-2104-Black	40	40-2093 Right Hand with Single Long Pin (Qty. 1)	40-2095 Right Hand with Single Short Pin (Qty. 1)	40-2097 Mating Hub (Qty. 2)	Black Anodize	.1633 kg	
65-2101	25 to 40	40-2093 Right Hand with Single Long Pin (Qty. 1)	40-2095 Right Hand with Single Short Pin (Qty. 1)	25-2077 Mating Hub (Qty. 2)	Clear Anodize	.1280 kg	
65-2101-Black	25 to 40	40-2093 Right Hand with Single Long Pin (Qty. 1)	40-2095 Right Hand with Single Short Pin (Qty. 1)	25-2077 Mating Hub (Qty. 2)	Black Anodize	.1280 kg	

Standard Lift-Off Hinge - Left Hand Assembly

Part Description:

The standard lift-off hinge - left hand assembly is comprised of one standard lift-off hinge - left hand with single long pin, one standard lift-off hinge - left hand with single short pin, and two standard lift-off hinge - mating hubs.

Part No.	Series	Assembly Components			Finish	Weight	Product Representation
2065	10	2074 Left Hand with Single Long Pin (Qty. 1)	2076 Left Hand with Single Short Pin (Qty. 1)	2077 Mating Hub (Qty. 2)	Clear Anodize	.212 lb	
2065-Black	10	2074 Left Hand with Single Long Pin (Qty. 1)	2076 Left Hand with Single Short Pin (Qty. 1)	2077 Mating Hub (Qty. 2)	Black Anodize	.212 lb	
2105	15	2094 Left Hand with Single Long Pin (Qty. 1)	2096 Left Hand with Single Short Pin (Qty. 1)	2097 Mating Hub (Qty. 2)	Clear Anodize	.323 lb	
2105-Black	15	2094 Left Hand with Single Long Pin (Qty. 1)	2096 Left Hand with Single Short Pin (Qty. 1)	2097 Mating Hub (Qty. 2)	Black Anodize	.323 lb	
2102	10 to 15	2094 Left Hand with Single Long Pin (Qty. 1)	2096 Left Hand with Single Short Pin (Qty. 1)	2077 Mating Hub (Qty. 2)	Clear Anodize	.268 lb	
2102-Black	10 to 15	2094 Left Hand with Single Long Pin (Qty. 1)	2096 Left Hand with Single Short Pin (Qty. 1)	2077 Mating Hub (Qty. 2)	Black Anodize	.268 lb	
25-2065	25	25-2074 Left Hand with Single Long Pin (Qty. 1)	25-2076 Left Hand with Single Short Pin (Qty. 1)	25-2077 Mating Hub (Qty. 2)	Clear Anodize	.0928 kg	
25-2065-Black	25	25-2074 Left Hand with Single Long Pin (Qty. 1)	25-2076 Left Hand with Single Short Pin (Qty. 1)	25-2077 Mating Hub (Qty. 2)	Black Anodize	.0928 kg	
40-2105	40	40-2094 Left Hand with Single Long Pin (Qty. 1)	40-2096 Left Hand with Single Short Pin (Qty. 1)	40-2097 Mating Hub (Qty. 2)	Clear Anodize	.1637 kg	
40-2105-Black	40	40-2094 Left Hand with Single Long Pin (Qty. 1)	40-2096 Left Hand with Single Short Pin (Qty. 1)	40-2097 Mating Hub (Qty. 2)	Black Anodize	.1637 kg	
65-2102	25 to 40	40-2094 Left Hand with Single Long Pin (Qty. 1)	40-2096 Left Hand with Single Short Pin (Qty. 1)	25-2077 Mating Hub (Qty. 2)	Clear Anodize	.1270 kg	
65-2102-Black	25 to 40	40-2094 Left Hand with Single Long Pin (Qty. 1)	40-2096 Left Hand with Single Short Pin (Qty. 1)	25-2077 Mating Hub (Qty. 2)	Black Anodize	.1270 kg	

Part Description:

The standard captive lift-off hinge assembly is comprised of one standard lift-off hinge - right hand with single short pin, one standard lift-off hinge - left hand with single short pin, and one standard lift-off hinge - mating hub.

Part No.	Series	Assembly Components			Finish	Weight	Product Representation
2066	10	2075 Right Hand with Single Short Pin (Qty. 1)	2076 Left Hand with Single Short Pin (Qty. 1)	2077 Mating Hub (Qty. 1)	Clear Anodize	.160 lb	
2066-Black	10	2075 Right Hand with Single Short Pin (Qty. 1)	2076 Left Hand with Single Short Pin (Qty. 1)	2077 Mating Hub (Qty. 1)	Black Anodize	.160 lb	
2106	15	2095 Right Hand with Single Short Pin (Qty. 1)	2096 Left Hand with Single Short Pin (Qty. 1)	2097 Mating Hub (Qty. 1)	Clear Anodize	.242 lb	
2106-Black	15	2095 Right Hand with Single Short Pin (Qty. 1)	2096 Left Hand with Single Short Pin (Qty. 1)	2097 Mating Hub (Qty. 1)	Black Anodize	.242 lb	
2103	10 to 15	2095 Right Hand with Single Short Pin (Qty. 1)	2096 Left Hand with Single Short Pin (Qty. 1)	2077 Mating Hub (Qty. 1)	Clear Anodize	.214 lb	
2103-Black	10 to 15	2095 Right Hand with Single Short Pin (Qty. 1)	2096 Left Hand with Single Short Pin (Qty. 1)	2077 Mating Hub (Qty. 1)	Black Anodize	.214 lb	
25-2066	25	25-2075 Right Hand with Single Short Pin (Qty. 1)	25-2076 Left Hand with Single Short Pin (Qty. 1)	25-2077 Mating Hub (Qty. 1)	Clear Anodize	.0696 kg	
25-2066-Black	25	25-2075 Right Hand with Single Short Pin (Qty. 1)	25-2076 Left Hand with Single Short Pin (Qty. 1)	25-2077 Mating Hub (Qty. 1)	Black Anodize	.0696 kg	
40-2106	40	40-2095 Right Hand with Single Short Pin (Qty. 1)	40-2096 Left Hand with Single Short Pin (Qty. 1)	40-2097 Mating Hub (Qty. 1)	Clear Anodize	.0417 kg	
40-2106-Black	40	40-2095 Right Hand with Single Short Pin (Qty. 1)	40-2096 Left Hand with Single Short Pin (Qty. 1)	40-2097 Mating Hub (Qty. 1)	Black Anodize	.0417 kg	
65-2103	25 to 40	40-2095 Right Hand with Single Short Pin (Qty. 1)	40-2096 Left Hand with Single Short Pin (Qty. 1)	25-2077 Mating Hub (Qty. 1)	Clear Anodize	.1044 kg	
65-2103-Black	25 to 40	40-2095 Right Hand with Single Short Pin (Qty. 1)	40-2096 Left Hand with Single Short Pin (Qty. 1)	25-2077 Mating Hub (Qty. 1)	Black Anodize	.1044 kg	

Bi-Fold Door Configuration

Bi-Fold Door Application Example

Designing a bi-fold door using 80/20[®] products is a straight-forward process. Simply remember to include the hinge and opening gaps when sizing the inside dimension of your door, while taking into account the profile size. Follow the steps listed and reference the drawing for the standard method of designing a bi-fold door.

- Step 1:** Select the profile you will use for building your bi-fold door. Typically this is the same as the frame.
- Step 2:** Determine the opening width of your door.
- Step 3:** Choose your hinge type and find the standard gap between profiles when using that hinge.
- Step 4:** Choose the total width for each inside door, remembering to subtract the hinge and clearance gaps.

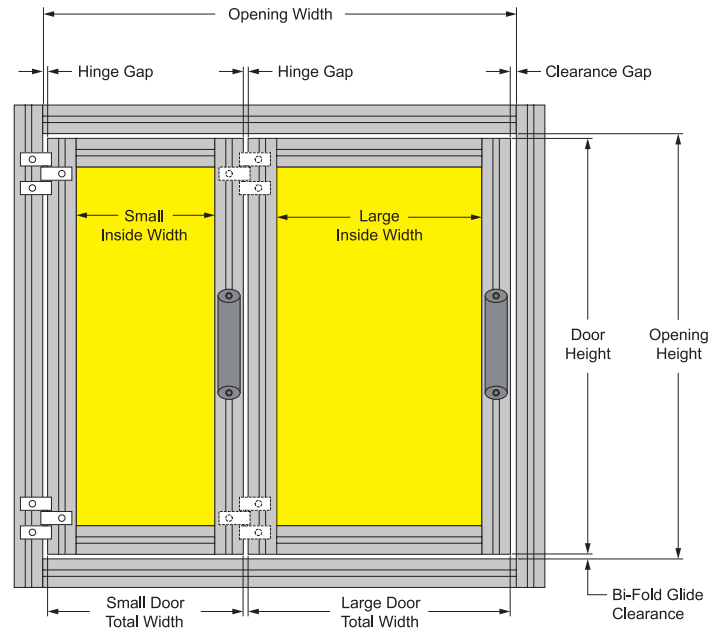

Framed & Unframed Doors

- For both framed and unframed doors the hinge side gap depends on hinge.
- Framed Doors: There is a 1/4" (6.35mm) top, bottom and handle gap. When using door gasket subtract 1/8" (3.175mm).
- Unframed Doors: There is a 1/8" (3.175mm) top, bottom and handle gap.

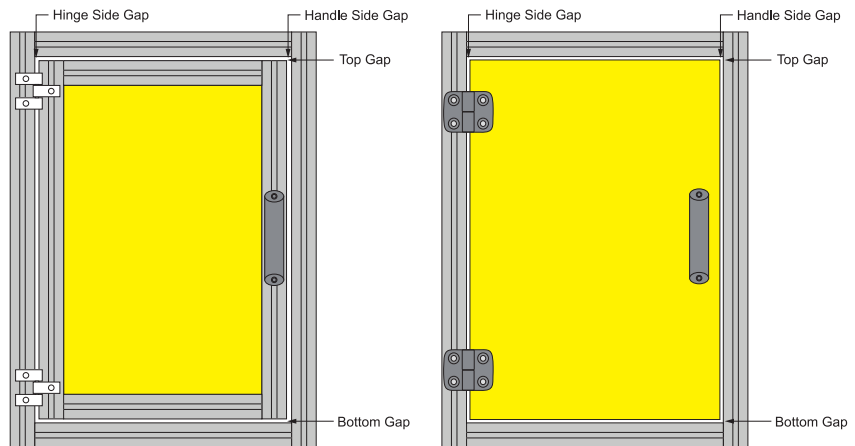

Framed Door

Unframed Door

Economy Lift-Off Hinge Right Hand with Long Pin

Part Description:

The economy lift-off hinge right hand with long pin is a cost-effective option made of aluminum and commonly used in lightweight doors. When the long pin is placed in the upper position it simplifies door assembly. Hinges with long pins are commonly used to create lift off hinge assemblies (page 533 for assembly options).

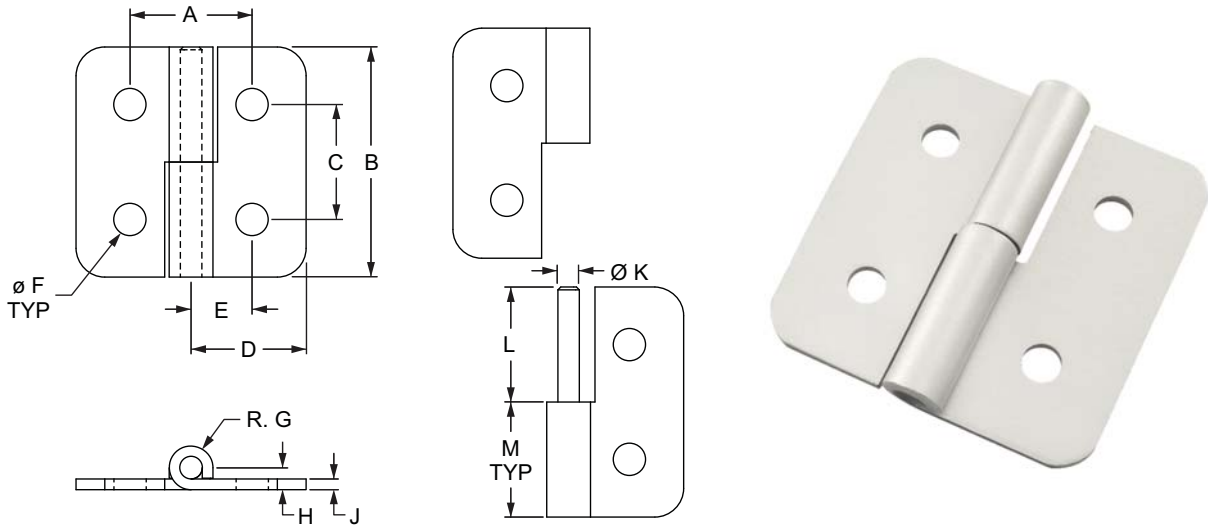

Part No.	Series	Max Load	A	B	C	D	E	F	G	H	J	K	L	M	Weight
2838	10	40 lb	1.062"	2.000"	1.000"	1.000"	.531"	.281"	.191"	.191"	.093"	.187"	1.000"	1.000"	.047 lb
2840	15	70 lb	1.620"	3.000"	1.500"	1.500"	.812"	.328"	.250"	.250"	.120"	.250"	1.500"	1.500"	.140 lb
25-2838	25	18 kg	26.97mm	50.80mm	25.40mm	25.40mm	13.48mm	7.13mm	4.85mm	4.85mm	2.36mm	4.75mm	25.40mm	25.40mm	.0208 kg
40-2840	40	32 kg	41.15mm	76.20mm	38.10mm	38.10mm	20.62mm	8.30mm	6.35mm	6.35mm	3.05mm	6.35mm	50.80mm	50.80mm	.0642 kg

*The gap distance between profiles for 10 series is .062", 15 series is .120", 25 series is 1.97mm, 40 series is 1.15mm.

Material Specifications

Material	Alloy	Finish	Process
Aluminum	5052-H32 = Leaf 6061-T6 = Pin	Clear Anodize	Milled

Suggested Hardware (Mount to T-Slot)

Part No.	Series	Qty.	Bolt	T-Nut
3386	10	4	1/4-20 x 3/8 FBHSCS	Economy
3319	15	4	5/16-18 x 1/2 FBHSCS	Economy
75-3404	25	4	M6 x 10mm BHSCS	Economy
75-3421	40	4	M8 x 12mm BHSCS	Economy

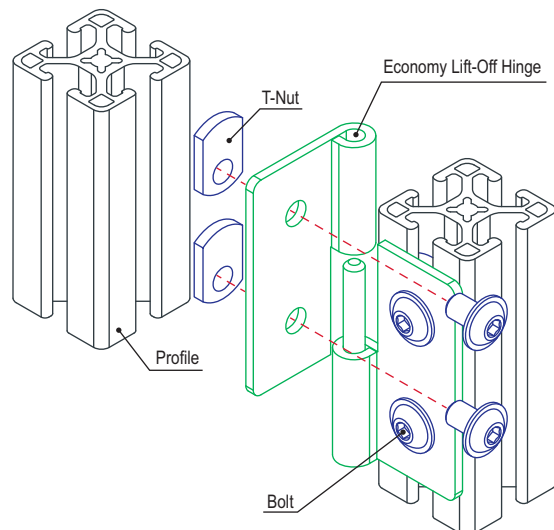

Economy Lift-Off Hinge Right Hand with Short Pin

Part Description:

The economy lift-off hinge right hand with short pin is a cost-effective option made of aluminum and commonly used in lightweight doors. Hinges with short pins are commonly used to create lift-off assemblies (page 533 for assembly options).

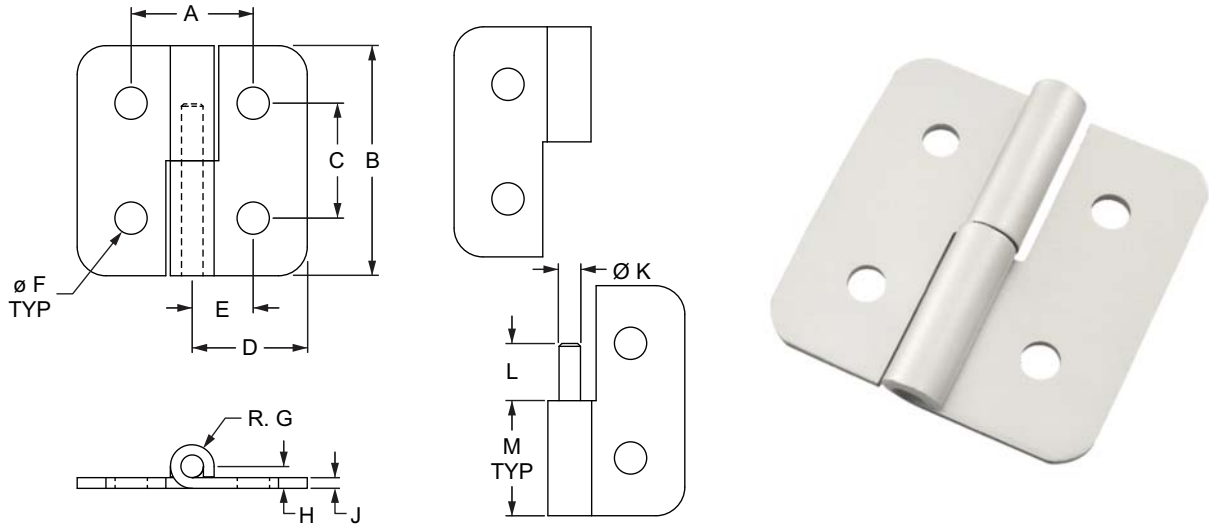

Part No.	Series	Max Load	A	B	C	D	E	F	G	H	J	K	L	M	Weight
2837	10	40 lb	1.062"	2.000"	1.000"	1.000"	.531"	.281"	.191"	.191"	.093"	.187"	.500"	1.000"	.045 lb
2839	15	70 lb	1.620"	3.000"	1.500"	1.500"	.812"	.328"	.250"	.250"	.120"	.250"	.750"	1.500"	.134 lb
25-2837	25	18 kg	26.97mm	50.80mm	25.40mm	25.40mm	13.48mm	7.13mm	4.85mm	4.85mm	2.36mm	4.75mm	12.70mm	25.40mm	.0200 kg
40-2839	40	32 kg	41.15mm	76.20mm	38.10mm	38.10mm	20.62mm	8.30mm	6.35mm	6.35mm	3.05mm	6.35mm	19.05mm	50.80mm	.2758 kg

*The gap distance between profiles for 10 series is .062", 15 series is .120", 25 series is 1.97mm, 40 series is 1.15mm.

Material Specifications

Material	Alloy	Finish	Process
Aluminum	5052-H32 = Leaf 6061-T6 = Pin	Clear Anodize	Milled

Suggested Hardware (Mount to T-Slot)

Part No.	Series	Qty.	Bolt	T-Nut
3386	10	4	1/4-20 x 3/8 FBHSCS	Economy
3319	15	4	5/16-18 x 1/2 FBHSCS	Economy
75-3404	25	4	M6 x 10mm BHSCS	Economy
75-3421	40	4	M8 x 12mm BHSCS	Economy

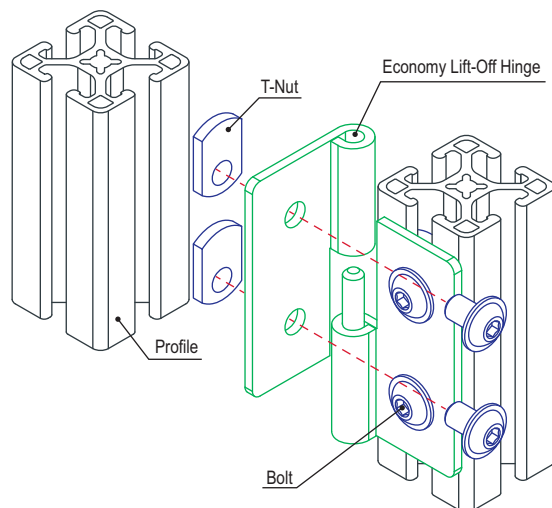

Economy Lift-Off Hinge Left Hand with Long Pin

Part Description:

The economy lift-off hinge left hand with long pin is a cost-effective option made of aluminum and commonly used in lightweight doors. When the long pin is placed in the upper position it simplifies door assembly. Hinges with long pins are commonly used to create lift off hinge assemblies (page 533 for assembly options).

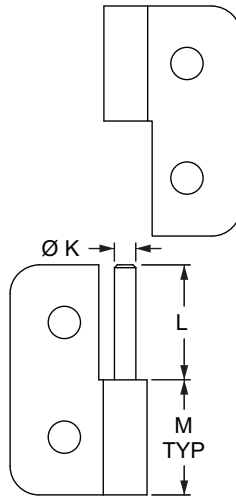
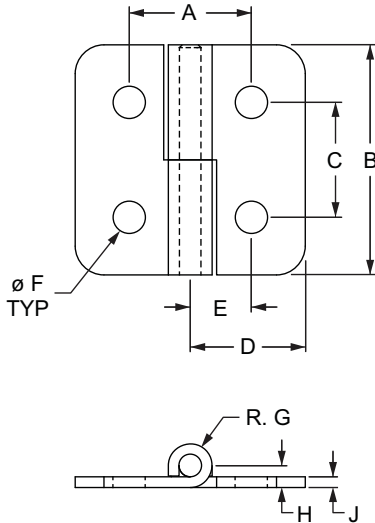

Part No.	Series	Max Load	A	B	C	D	E	F	G	H	J	K	L	M	Weight
2831	10	40 lb	1.062"	2.000"	1.000"	1.000"	.531"	.281"	.191"	.191"	.093"	.187"	1.000"	1.000"	.045 lb
2833	15	70 lb	1.620"	3.000"	1.500"	1.500"	.812"	.328"	.250"	.250"	.120"	.250"	1.500"	1.500"	.134 lb
25-2831	25	18 kg	26.97mm	50.80mm	25.40mm	25.40mm	13.48mm	7.13mm	4.85mm	4.85mm	2.36mm	4.75mm	25.40mm	25.40mm	.02041 kg
40-2833	40	32 kg	41.15mm	76.20mm	38.10mm	30.52mm	20.62mm	8.30mm	6.35mm	6.35mm	3.05mm	6.35mm	50.80mm	50.80mm	.0629 kg

*The gap distance between profiles for 10 series is .062", 15 series is .120", 25 series is 1.97mm, 40 series is 1.15mm.

Material Specifications

Material	Alloy	Finish	Process
Aluminum	5052-H32 = Leaf 6061-T6 = Pin	Clear Anodize	Milled

Suggested Hardware (Mount to T-Slot)

Part No.	Series	Qty.	Bolt	T-Nut
3386	10	4	1/4-20 x 3/8 FBHSCS	Economy
3319	15	4	5/16-18 x 1/2 FBHSCS	Economy
75-3404	25	4	M6 x 10mm BHSCS	Economy
75-3421	40	4	M8 x 12mm BHSCS	Economy

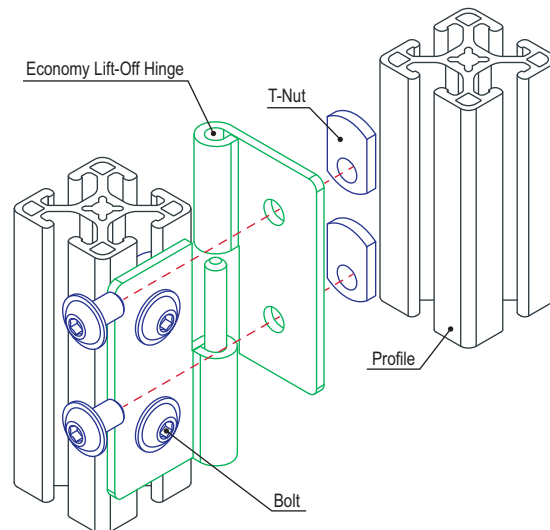

Economy Lift-Off Hinge Left Hand with Short Pin

Part Description:

The economy lift-off hinge left hand with short pin is a cost-effective option made of aluminum and commonly used in lightweight doors. Hinges with short pins are commonly used to create lift-off assemblies (page 533 for assembly options).

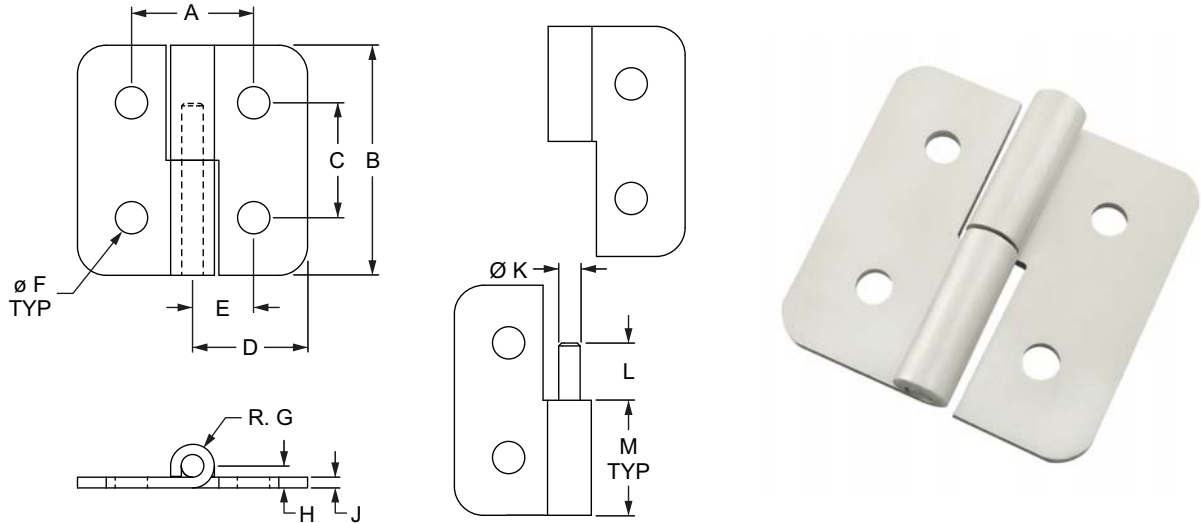

Part No.	Series	Max Load	A	B	C	D	E	F	G	H	J	K	L	M	Weight
2830	10	40 lb	1.062"	2.000"	1.000"	1.000"	.531"	.281"	.191"	.191"	.093"	.187"	.500"	1.000"	.045 lb
2832	15	70 lb	1.620"	3.000"	1.500"	1.500"	.812"	.328"	.250"	.250"	.120"	.250"	1.500"	1.500"	.134 lb
25-2830	25	18 kg	26.97mm	50.80mm	25.40mm	25.40mm	13.48mm	7.13mm	4.85mm	4.85mm	2.36mm	4.75mm	12.70mm	25.40mm	.0090 kg
40-2832	40	32 kg	41.15mm	76.20mm	38.10mm	41.02mm	20.62mm	8.30mm	6.35mm	6.35mm	3.05mm	6.35mm	19.05mm	50.80mm	.0607 kg

*The gap distance between profiles for 10 series is .062", 15 series is .120", 25 series is 1.97mm, 40 series is 1.15mm.

Material Specifications

Material	Alloy	Finish	Process
Aluminum	5052-H32 = Leaf 6061-T6 = Pin	Clear Anodize	Milled

Suggested Hardware (Mount to T-Slot)

Part No.	Series	Qty.	Bolt	T-Nut
3386	10	4	1/4-20 x 3/8 FBHSCS	Economy
3319	15	4	5/16-18 x 1/2 FBHSCS	Economy
75-3404	25	4	M6 x 10mm BHSCS	Economy
75-3421	40	4	M8 x 12mm BHSCS	Economy

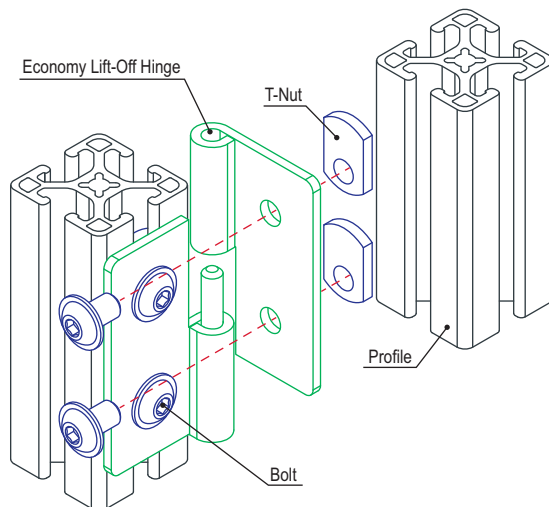

Part Description:

The economy lift-off hinge assembly is a cost-effective option commonly used to create lift-off hinges for lightweight doors. It is available in a right-hand and a left-hand orientation. Each assembly is comprised of two hinges; one long pin hinge and one short pin hinge.

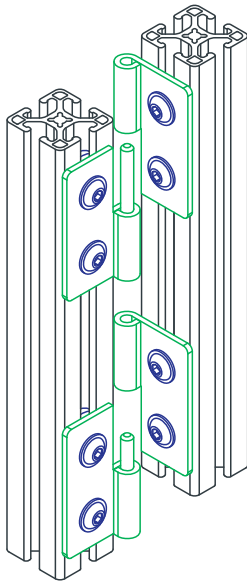
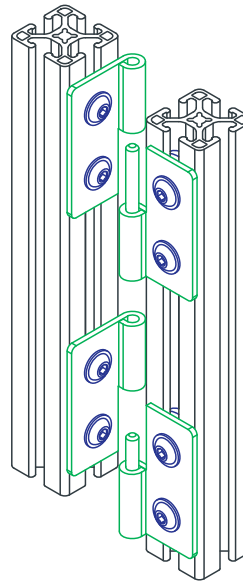
**Left Hinge: 2835, 25-2835****Left Hinge: 2836, 40-2836****Right Hinge: 2841, 25-2841****Right Hinge: 2842, 40-2842**

Part No.	Series	Orientation	Material	Alloy	Finish	Process	Weight
2841	10	Right Hinge	Aluminum	5052-H32 = Leaf 6061-T6 = Pin	Clear Anodize	Milled	.090 lb
2835	10	Left Hinge					.088 lb
2842	15	Right Hinge					.270 lb
2836	15	Left Hinge					.270 lb
25-2841	25	Right Hinge					.0186 kg
25-2835	25	Left Hinge					.0181 kg
40-2842	40	Right Hinge					.1211 kg
40-2836	40	Left Hinge					.1220 kg

* Hinge assemblies include (2) hinges; one long pin, and one short pin.

Suggested Hardware (Mount to T-Slot)

Part No.	Series	Qty.	Bolt	T-Nut
3386	10	8	1/4-20 x 3/8 FBHSCS	Economy
3319	15	8	5/16-18 x 1/2 FBHSCS	Economy
75-3404	25	8	M6 x 10mm BHSCS	Economy
75-3421	40	8	M8 x 12mm BHSCS	Economy

4 Hole - Concealed Hinge

Part Description:

The 4 hole - concealed hinge allows you to design doors with hidden hinges when the door is closed. The hinge mounts to the inside of the frame, which makes enclosures more secure; they are not able to be dismantled when the door is shut.

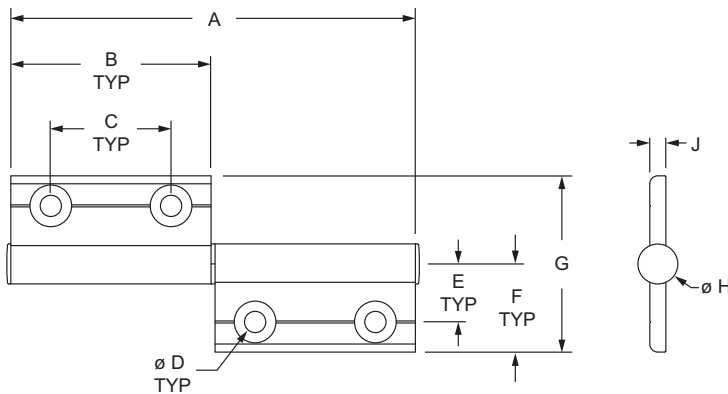

Part No.	Series	A	B	C	D	E	F	G	H	J*	Weight
2324	20	3.976"	1.969"	1.181"	.209"	.571"	.866"	1.732"	.394"	.157"	.033 lb
2325	10 25	3.976"	1.969"	1.181"	.252"	.689"	1.102"	2.205"	.394"	.157"	.040 lb
2326	30	3.976"	1.969"	1.181"	.252"	.768"	1.260"	2.520"	.394"	.157"	.044 lb
2327	15 40	3.976"	1.969"	1.181"	.252"	.984"	1.654"	3.307"	.394"	.157"	.055 lb
2328	45	3.976"	1.969"	1.181"	.252"	1.063"	1.850"	3.701"	.394"	.157"	.062 lb

*Dimension "J" also defines the hinge gap between two profiles.

Material Specifications

Material	Alloy	Finish	Process
Aluminum	6060	Clear Anodize	Extruded

Suggested Hardware (Mount to T-Slot)

Series	Part No.	Qty.	Bolt	Part No.	Qty.	T-Nut
20	11-5708	4	M5 x 8mm FHSCS	14122	4	Slide-in
10 25	13-6710	4	M6 x 10mm FHSCS	25-1961	4	Slide-in
30	13-6712	4	M6 x 12mm FHSCS	30-1961	4	Slide-in
15	11-6714	4	M6 x 14mm FHSCS	3836	4	Slide-in
40	11-6714	4	M6 x 14mm FHSCS	40-1961	4	Slide-in
45	13-6716	4	M8 x 16mm FHSCS	14126	4	Slide-in

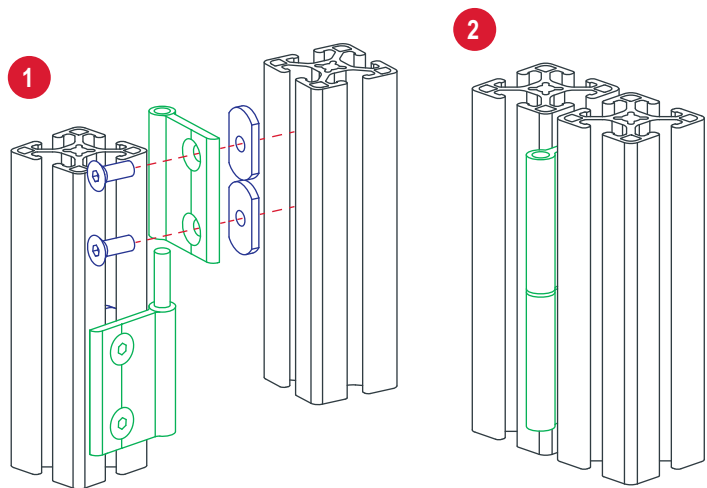

Open View

Closed View

4 Hole - Plastic Lift-Off Hinge

Part Description:

The 4 hole - plastic lift-off hinge comes in both right and left hand options and is made of fiberglass-reinforced black nylon with a stainless steel pin. It is commonly used to connect plastic panels and lightweight doors to T-slot profiles and is available in options with slot tabs to assist with alignment.

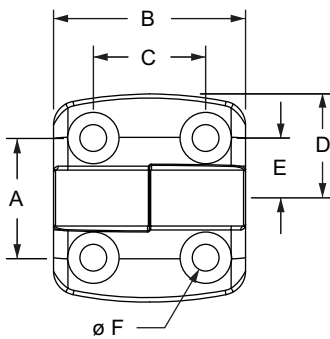

Left Hand

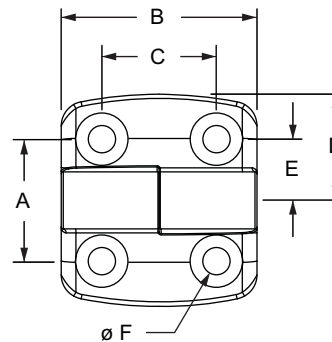
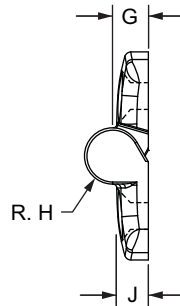

Right Hand

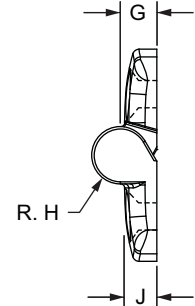

Part No.	Series	Orientation	Max Load	Slot Tab	A	B	C	D	E	F	G	H	J	Weight
12101	10 25	Left Hand	25 Nm / 18 ft-Lbs.	—	30.00mm	48.00mm	28.00mm	26.00mm	15.00mm	6.60mm	8.95mm	7.00mm	7.90mm	.0329 kg
12102	10 25	Left Hand		6.00mm	30.00mm	48.00mm	28.00mm	26.00mm	15.00mm	6.60mm	8.90mm	7.00mm	7.90mm	.0337 kg
12104	10 25	Right Hand		—	30.00mm	48.00mm	28.00mm	26.00mm	15.00mm	6.60mm	8.95mm	7.00mm	7.90mm	.0334 kg
12105	10 25	Right Hand		6.00mm	30.00mm	48.00mm	28.00mm	26.00mm	15.00mm	6.60mm	8.90mm	7.00mm	7.90mm	.0335 kg
12119	15	Left Hand	25 ft-Lbs.	—	40.00mm	48.00mm	28.00mm	35.50mm	20.00mm	6.60mm	8.90mm	7.00mm	8.70mm	.0404 kg
12120	15	Left Hand		8.00mm	40.00mm	48.00mm	28.00mm	35.50mm	20.00mm	6.60mm	8.90mm	7.00mm	7.90mm	.0399 kg
12122	15	Right Hand		—	40.00mm	48.00mm	28.00mm	35.50mm	20.00mm	6.60mm	8.90mm	7.00mm	7.90mm	.0403 kg
12123	15	Right Hand		8.00mm	40.00mm	48.00mm	28.00mm	35.50mm	20.00mm	6.60mm	8.90mm	7.00mm	7.90mm	.0399 kg
12128	15 40	Left Hand	35 Nm / 25 ft-Lbs.	—	45.00mm	48.00mm	28.00mm	38.50mm	22.50mm	6.60mm	8.90mm	7.00mm	7.90mm	.0429 kg
12129	15 40	Left Hand		8.00mm	45.00mm	48.00mm	28.00mm	38.50mm	22.50mm	6.60mm	8.90mm	7.00mm	7.50mm	.0437 kg
12131	15 40	Right Hand		—	45.00mm	48.00mm	28.00mm	38.50mm	22.50mm	6.60mm	8.90mm	7.00mm	7.60mm	.0438 kg
12132	15 40	Right Hand		8.00mm	45.00mm	48.00mm	28.00mm	38.50mm	22.50mm	6.60mm	8.90mm	7.00mm	7.50mm	.0449 kg

*The gap distance between profiles is .075" (1.90mm)

CONTINUE

4 Hole - Plastic Lift-Off Hinge (Continued)

Part No.	Series	Orientation	Max Load	Slot Tab	A	B	C	D	E	F	G	H	J	Weight
12110	30	Left Hand	25 Nm / 18 ft-Lbs.	—	35.00mm	48.00mm	28.00mm	29.50mm	17.50mm	6.60mm	8.90mm	7.00mm	8.50mm	.0367 kg
12111	30	Left Hand		8.00mm	35.00mm	48.00mm	28.00mm	29.50mm	17.50mm	6.60mm	8.90mm	7.00mm	7.90mm	.0365kg
12113	30	Right Hand		—	35.00mm	48.00mm	28.00mm	29.50mm	17.50mm	6.60mm	8.90mm	7.00mm	8.40mm	.0374 kg
12114	30	Right Hand		8.00mm	35.00mm	48.00mm	28.00mm	29.50mm	17.50mm	6.60mm	8.90mm	7.00mm	7.20mm	.0358 kg
12137	45	Left Hand	35 Nm / 25 ft-Lbs.	—	50.00mm	48.00mm	28.00mm	43.50mm	25.00mm	6.60mm	8.90mm	7.00mm	7.90mm	.0469 kg
12139	45	Left Hand		10.00mm	50.00mm	48.00mm	28.00mm	43.50mm	25.00mm	6.60mm	8.90mm	7.00mm	7.90mm	.0467 kg
12140	45	Right Hand		—	50.00mm	48.00mm	28.00mm	43.50mm	25.00mm	6.60mm	8.90mm	7.00mm	7.60mm	.0470 kg
12142	45	Right Hand		10.00mm	50.00mm	48.00mm	28.00mm	43.50mm	25.00mm	6.60mm	8.90mm	7.00mm	7.60mm	.0469 kg

*The gap distance between profiles is .075" (1.90mm)

Material Specifications

Material	Grade	Color	Process
Nylon PA Glass Fiber Reinforced	PA6GF30	Black	Injection Molding

Suggested Hardware Per Leaf (Mount to Panel)

Part No.	Series	Qty.	Bolt	Hex Nut	Washer
75-3589	10 15 25 30 40 45	2	M6 x 20mm FHSCS	Yes	Yes

Suggested Hardware Per Leaf (Mount to T-Slot)

Part No.	Series	Qty.	Bolt	T-Nut
75-3584	10 25	2	M6 x 14mm FHSCS	Slide-in
75-3585	30	2	M6 x 14mm FHSCS	Drop-in
75-3628	15 40	2	M6 x 18mm FHSCS	Drop-in
75-3587	45	2	M6 x 18mm FHSCS	Drop-in

Left Hand

Pin on the left, door opens right to left

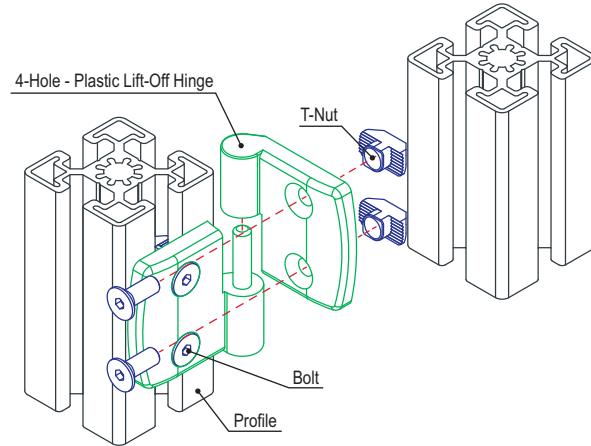

Right Hand

Pin on the right, door opens left to right

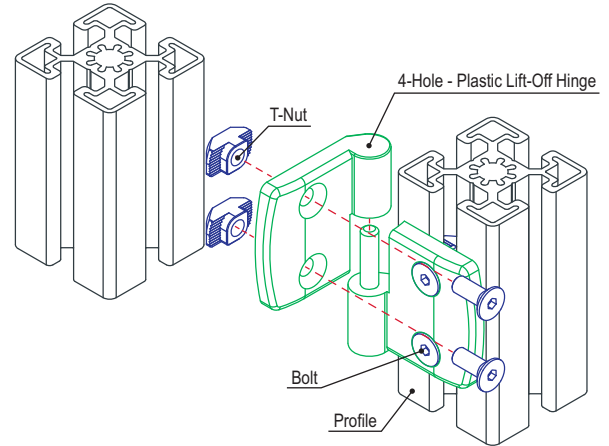

Part Description:

The 2 hole - plastic lift-off hinge comes in both right and left hand options and is made of fiberglass-reinforced black nylon with a stainless steel pin. It is commonly used to connect plastic panels and lightweight doors to T-slot profiles.

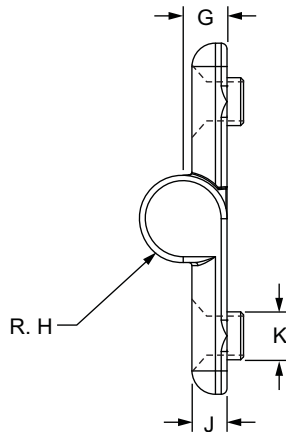
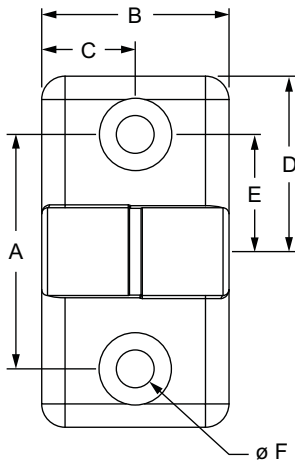

Part No.	Series	Orientation	Max Load	A	B	C	D	E	F	G	H	J	K	Weight
12072	15	Left	20 ft.-Lbs.	1.575"	1.260"	.630"	1.181"	.787"	.252"	.295"	.295"	.236"	.323"	.046 lb
12073	15	Right		1.575"	1.260"	.630"	1.181"	.787"	.252"	.295"	.295"	.236"	.323"	.048 lb

*The gap distance between profiles is .075" (1.90mm)

Material Specifications

Material	Grade	Color	Process
Nylon PA Glass Fiber Reinforced	PA6GF30	Black	Injection Molding

Suggested Hardware (Mount to T-Slot)

Part No.	Series	Qty.	Bolt	T-Nut
75-3628	15	2	M6 x 18mm FHSCS	Drop-in

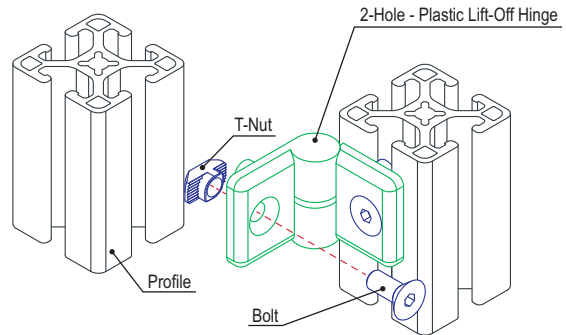

3 Hole - Plastic Double Lift-Off Hinge

Part Description:

The 3 hole - plastic double lift-off hinge comes in both right and left hand options and is made of fiberglass-reinforced black nylon with a stainless steel pin. It is commonly used with a combination of plastic panels and T-slot profiles to create adjacent access points.

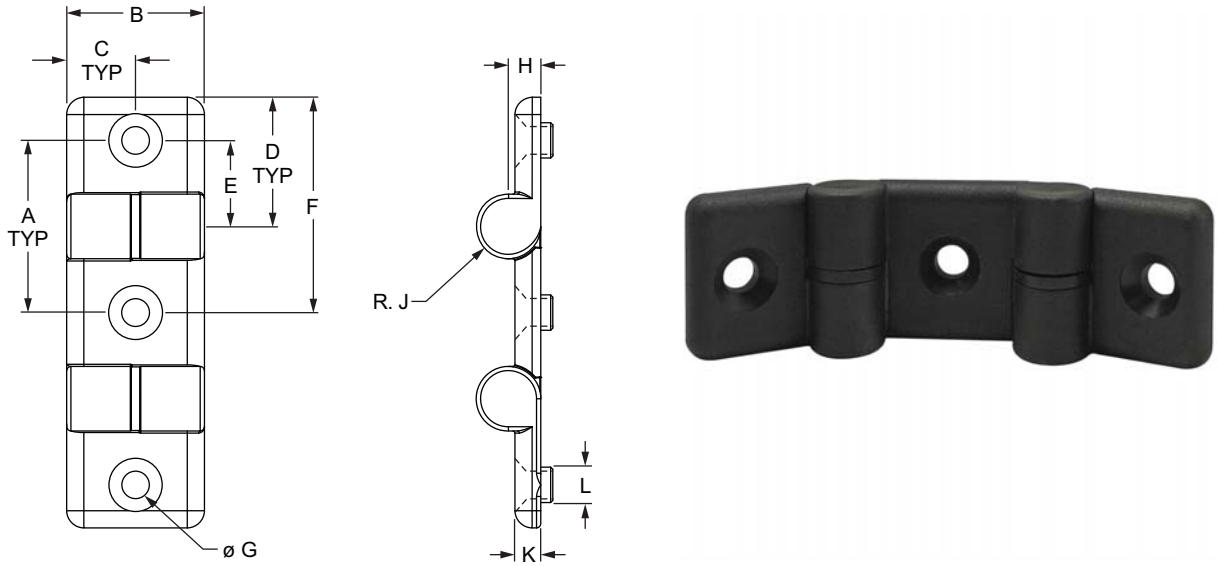

Part No.	Series	Max Load	A	B	C	D	E	F	G	H	J	K	L	Weight
12071	15	20 ft-Lbs.	1.575"	1.260"	.630"	1.181"	.787"	1.969"	.252"	.295"	.295"	.236"	.323"	.086 lb

*The gap distance between profiles is .075" (1.90mm)

Material Specifications

Material	Grade	Color	Process
Nylon PA Glass Fiber Reinforced	PA6GF30	Black	Injection Molding

Suggested Hardware (Mount to T-Slot)

Part No.	Series	Qty.	Bolt	T-Nut
75-3628	15	3	M6 x 18mm FHSCS	Drop-in

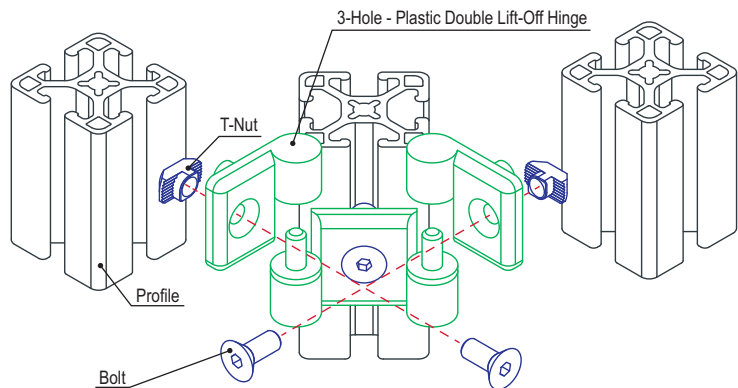

Part Description:

The 4 hole - dual hand lift-off hinge acts as both a right and left hand hinge. It is a stronger option that has a countersink on both sides to allow for right or left hand use. The 4 hole - dual hand lift-off hinge is commonly used to connect T-slot profiles.

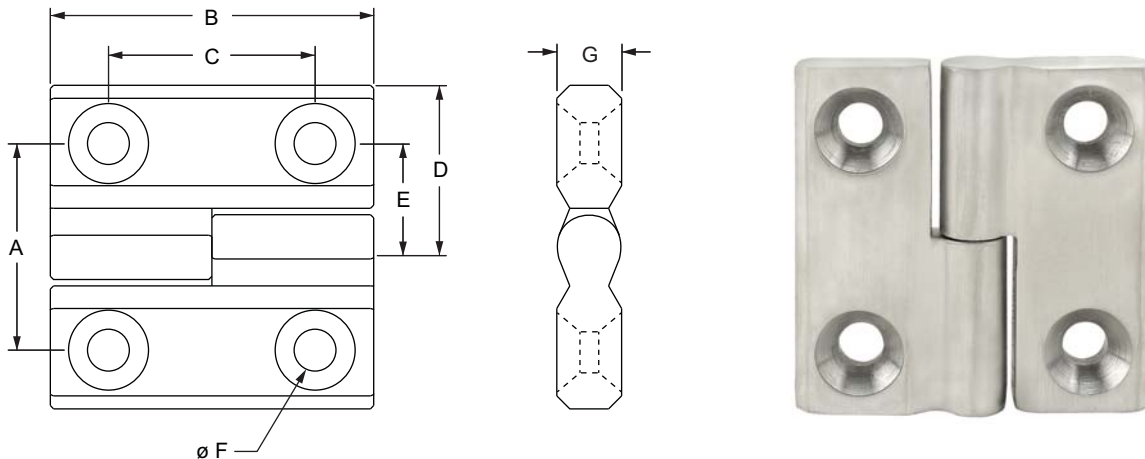

Part No.	Series	Max Load	A	B	C	D	E	F	G	Weight
12095	10 25 30	300 Nm / 221 ft-Lbs.	32.00mm	50.00mm	32.00mm	25.00mm	16.00mm	6.40mm	10.00mm	.1488 kg

Material Specifications

Material	Finish	Process	Color
Stainless-Steel	Stainless	Machined	Silver

Suggested Hardware (Mount to T-Slot)

Part No.	Series	Qty.	Bolt	T-Nut
75-3647	10 25	4	M6 x 16mm FHSCS	Roll-in
75-3591	30	4	M6 x 16mm FHSCS	Drop-in

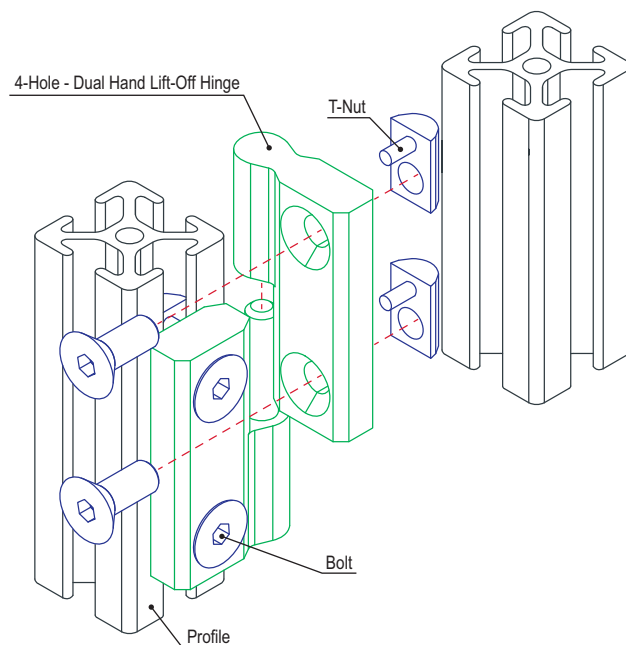

4 Hole - Adjustable Hinge

Part Description:

The 4 hole - universal, 4 hole - vertical, and 4 hole - horizontal adjustable hinges are die cast zinc with a black powder coat finish. They are commonly used to connect T-slot profiles. As their names imply, the universal hinge has both horizontal and vertical slotted holes while the vertical hinge has vertically slotted holes and the horizontal hinge has horizontally slotted holes. The slotted holes support fastening adjustments.



Universal



Vertical



Horizontal

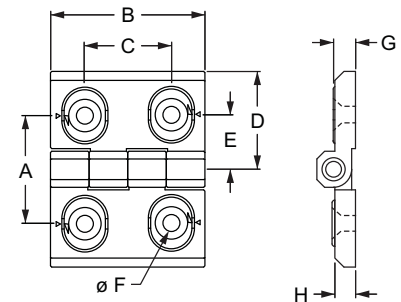
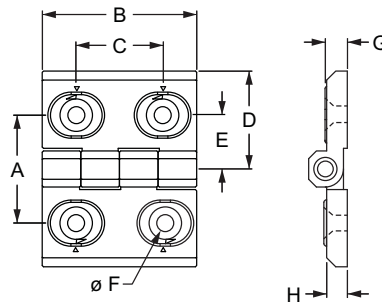
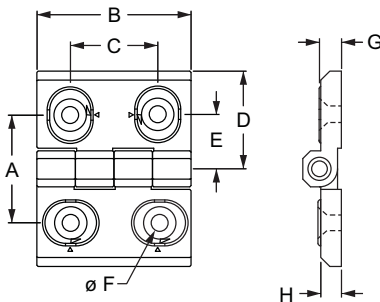

Part No.	Series	Orientation	Max Load	A	B	C	D	E	F	G	H	Weight
12068	15 40	Universal	300 Nm / 221 ft.-Lbs.	42.00mm	60.00mm	34.00mm	38.00mm	21.15mm	6.50mm	8.50mm	8.00mm	.2082 kg
12069	15 40	Vertical		42.00mm	60.00mm	34.00mm	38.00mm	21.00mm	6.00mm	8.50mm	8.00mm	.2075 kg
12070	15 40	Horizontal		42.00mm	60.00mm	34.00mm	38.00mm	21.00mm	6.50mm	8.50mm	8.00mm	.2048 kg

Material Specifications

Material	Grade	Finish	Process
Zinc	Die-Cast	Black Powder Coated	Die-Casting

Suggested Hardware Per Leaf (Mount to T-Slot)

Part No.	Series	Qty.	Bolt	T-Nut
75-3628	15 40	2	M6 x 18mm FHSCS	Drop-In

Suggested Hardware Per Leaf (Mount to Panel ≤ .250" / 6mm)

Part No.	Series	Qty.	Bolt	Hex Nut	Washer
75-3589	15 40	2	M6 x 20mm FHSCS	Yes	Yes

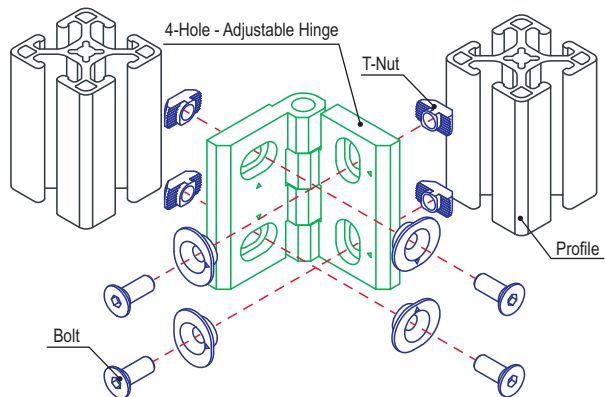

Part Description:

The 4 hole - adjustable tension panel hinge is comprised of black acetal with clear polycarbonate hinge pins. It is a durable and economical option and the adjustable pins have the ability to change the pivot tension when opening or closing an access point. The 4 hole - adjustable tension panel hinge mounts plastic panels and lightweight doors to T-slots. **Important:** This hinge is not suitable for connecting multiple T-slot profiles.

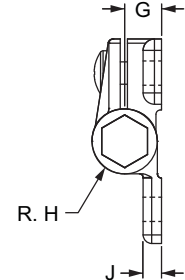
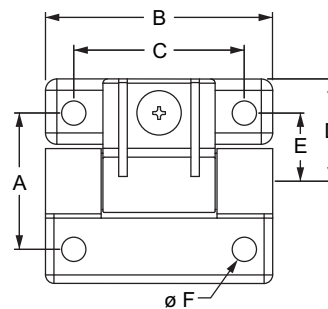
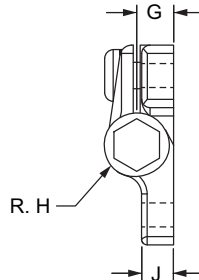
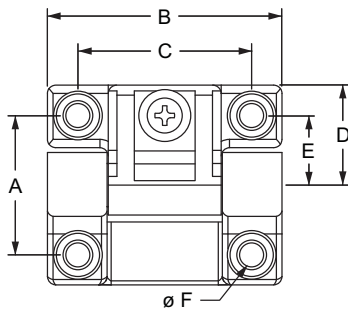
**2081****2080**

Part No.	Series	Material	Finish	Process	A	B	C	D	E	F	G	H	J	Weight
2081	10	Engineered Polymer	Matte Black	Injection Molded	1.000"	1.688"	1.250"	.719"	.500"	.172"	.266"	.234"	.230"	.031 lb
2080	15				1.500"	2.500"	1.875"	1.125"	.750"	.266"	.406"	.360"	.203"	.094 lb
25-2081	25				25.40mm	42.86mm	31.75mm	18.26mm	12.70mm	4.37mm	6.76mm	5.94mm	5.84mm	.0146 kg
40-2080	40				38.10mm	63.50mm	47.63mm	28.58mm	19.05mm	6.76mm	10.31mm	9.14mm	5.16mm	.0430 kg

Suggested Hardware Per Leaf (Mount to T-Slot)

Part No.	Series	Qty.	Bolt	T-Nut
3457	10	2	10-32 x 3/8 SHCS	Economy
3365	15	2	5/16-18 x 5/8 BHSCS	Economy
75-3401	25	2	M5 x 10mm SHCS	Economy
75-3422	40	2	M8 x 16mm BHSCS	Economy

Suggested Hardware Per Leaf (Mount to Panel ≤ .250" / 6mm)

Part No.	Series	Qty.	Bolt	Hex Nut	Washer
3459	10	2	10-32 x 5/8 SHCS	Yes	Yes
3442	15	2	5/16-18 x 3/4 BHSCS	Yes	Yes
75-3400	25	2	M5 x 16mm SHCS	Yes	Yes
75-3472	40	2	M8 x 20mm BHSCS	Yes	Yes

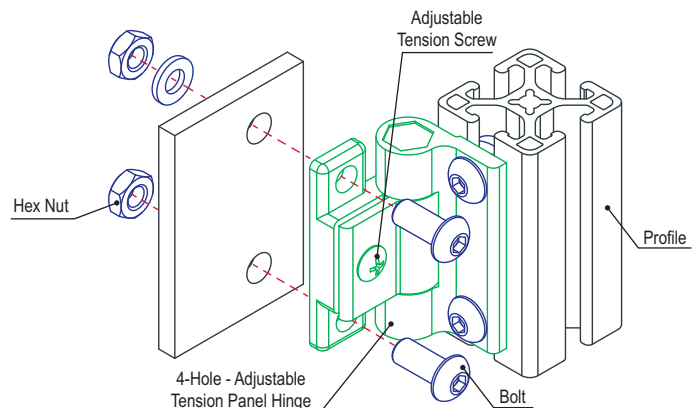

4 Hole - Detent Hinge

Part Description:

The 4 hole - detent hinge is commonly used to connect plastic panels and doors to T-slot profiles. It holds doors open at 120 or 170 degrees and is especially useful in horizontal-lifting applications, as it provides hands-free access. It includes snap-on covers that hide the hardware to mount to a panel or profile as well as a detent hinge stopper (page 470) and its mounting hardware. **Important:** This hinge is not suitable for connecting multiple T-slot profiles.



10 & 25 Series



15 & 40 Series

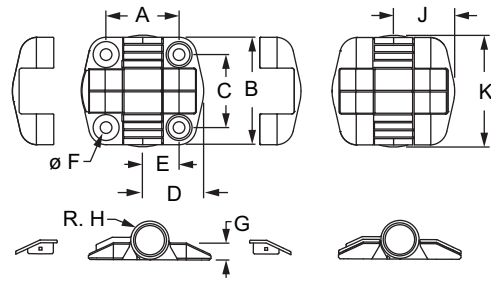
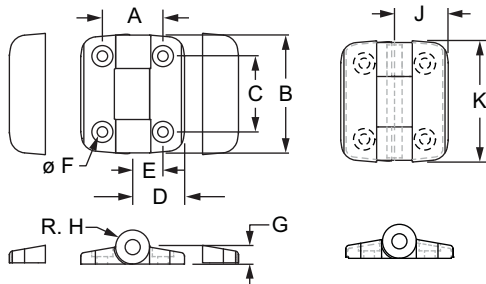

Part No.	Series	Color	A	B	C	D	E	F	G	H	J	K	Weight
2071	10	Black	1.000"	1.803"	1.252"	.791"	.492"	.177"	.283"	.264"	.839"	1.93"	.080 lb
2091	15	Black	1.339"	1.957"	1.339"	1.122"	.677"	.205"	.358"	.350"	1.122"	2.047"	.137 lb
25-2071	25	Black	25.40mm	45.80mm	31.80mm	20.10mm	12.50mm	4.50mm	7.20mm	6.70mm	21.30mm	49.00mm	.0362 kg
40-2091	40	Black	34.00mm	49.70mm	34.00mm	28.50mm	17.20mm	5.20mm	9.10mm	8.90mm	28.50mm	52.00mm	.0614 kg

Material Specifications

Material	Alloy	Finish	Process
Aluminum	6105	Anodize	Milled

Suggested Hardware Per Leaf (Mount to T-Slot)

Part No.	Series	Qty.	Bolt	T-Nut
3483	10	2	8-32 x 3/8 BHSCS	Economy
3487	15	2	10-32 x 1/2 BHSCS	Economy
75-3537	25	2	M4 x 10mm BHSCS	Economy
75-3583	40	2	M5 x 12mm BHSCS	Drop-in

Suggested Hardware Per Leaf (Mount to Panel ≤ .250" / 6mm)

Part No.	Series	Qty.	Bolt	Hex Nut	Washer
3489	10	2	8-32 x 1/2 BHSCS	Yes	Yes
3488	15	2	10-32 x 5/8 BHSCS	Yes	Yes
75-3538	25	2	M4 x 12mm BHSCS	Yes	Yes
75-3540	40	2	M5 x 16mm BHSCS	Yes	Yes

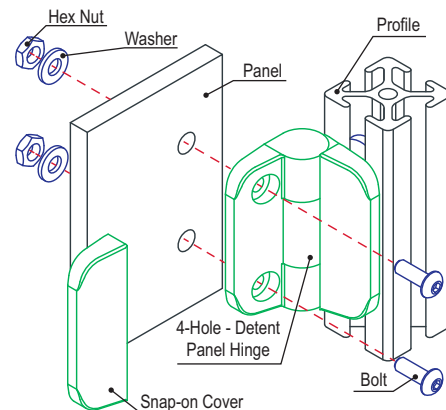

Part Description:

The 4 hole - detent positioning hinge is commonly used to connect plastic panels to profiles or to connect two profiles together. It holds doors open at 0, 85 or 175 degrees and is especially useful in horizontal-lifting applications, as it provides hands-free access. It has snap-on covers that hide the hardware for a clean appearance.

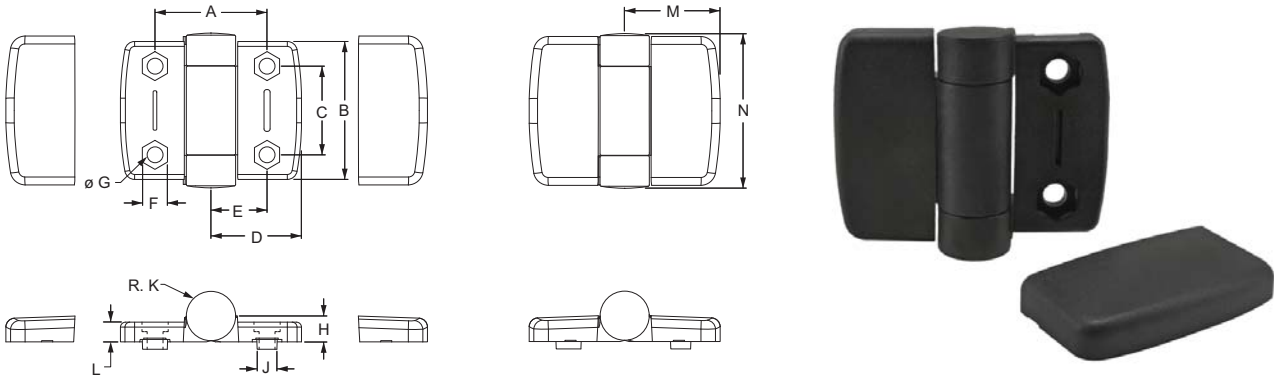

Part No.	Series	Max Load	A	B	C	D	E	F	G	H	J	K	L	M	N	Weight
12322	30	20 Nm / 14.7 Lbs.	35.50mm	56.00mm	36.00mm	27.00mm	17.75mm	10.20mm	6.40mm	10.50mm	—	10.00mm	8.00mm	27.50mm	62.80mm	.0735 kg
12326	15 40		45.50mm	56.00mm	36.00mm	36.75mm	22.75mm	10.20mm	6.40mm	10.50mm	—	10.00mm	8.00mm	38.75mm	62.80mm	.0838 kg
12327	15 40		45.50mm	56.00mm	36.00mm	36.75mm	22.75mm	10.20mm	6.40mm	10.50mm	8.00mm	10.00mm	8.00mm	38.75mm	62.80mm	.0845 kg

Material Specifications

Material	Grade	Process	Color
Nylon PA Glass Fiber Reinforced	PA6GF30	Injection Molded	Black

Suggested Hardware Per Leaf (Mount to T-Slot)

Part No.	Series	Qty.	Bolt	T-Nut
3418	15	2	1/4-20 x 5/8 BHSCS	Economy
75-3599	30	2	M6 x 10mm BHSCS	Drop-in
75-3622	40	2	M6 x 14mm BHSCS	Drop-in

Suggested Hardware Per Leaf (Mount to Panel ≤ .250" / 6mm)

Part No.	Series	Qty.	Bolt	Hex Nut	Washer
3469	15	2	1/4-20 x 3/4 BHSCS	Yes	Yes
75-3603	30	2	M6 x 14mm BHSCS	Yes	No
75-3605	40	2	M6 x 18mm BHSCS	Yes	Yes

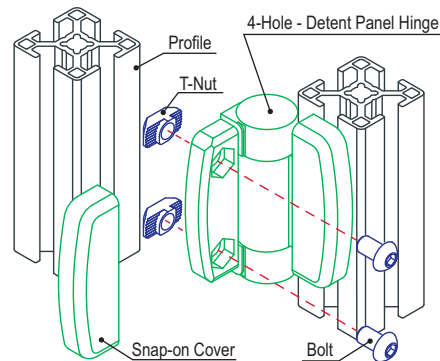

4 Hole - Constant Friction Hinge

Part Description:

The 4 hole - constant friction hinge is commonly used to connect plastic panels and doors to T-slot profiles. It holds doors open at variable angles and is especially useful for vertical-lifting smaller doors, as it provides hands-free access.

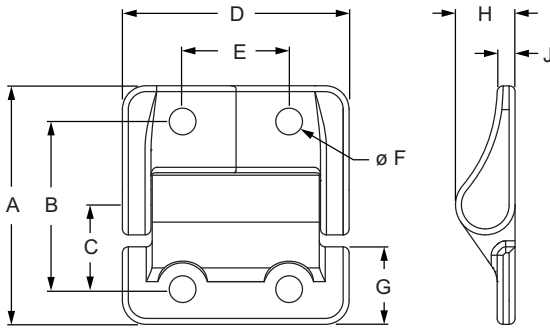

Part No.	Series	Material	Color	A	B	C	D	E	F	G	H	J	Weight
12080	10 25	Aluminum	Black	40.00mm	28.00mm	14.00mm	38.00mm	17.80mm	4.50mm	13.00mm	10.00mm	3.00mm	.0883 kg

Suggested Hardware Per Leaf (Mount to T-Slot)

Part No.	Series	Qty.	Bolt	Nut Type
75-3556	10 25	2	M4 x 10mm SHCS	Drop-In T-Nut

Suggested Hardware Per Leaf (Mount to Panel ≤ .250" / 6mm)

Part No.	Series	Qty.	Bolt	Nut Type	Washer
75-3558	10 25	2	M4 x 16mm SHCS	Hex Nut	11-6039

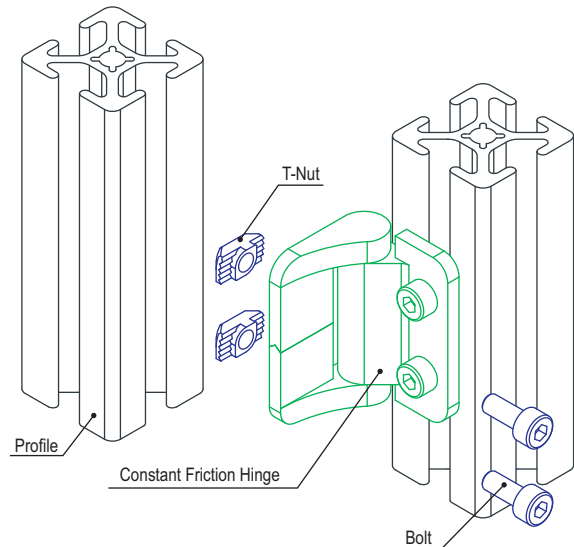

4 Hole - Aluminum Hinge

Part Description:

The 4 hole - aluminum hinge is commonly used to mount lighter weight doors or two profiles. It is a cost-effective option that is corrosion-resistant, making it useful for outdoor applications where standard hinges may rust or corrode. There are options available that can be used as a transition from 10 to 15 series or 25 to 40 series profiles.

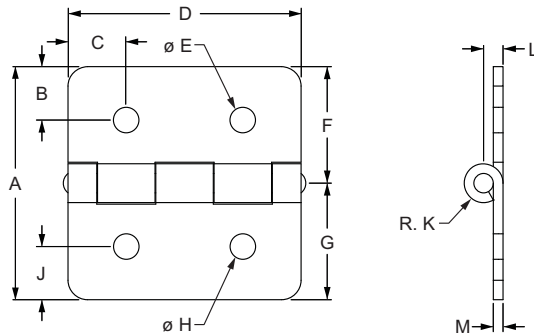

Part No.	Series	Color	Max Load	A	B	C	D	E	F	G	H	J	K	L	M	Weight
2086	10	Clear	40 lb	2.000"	.469"	.500"	2.000"	.257"	1.000"	1.000"	.257"	.469"	.167"	.167"	.078"	.040 lb
2086-Black	10	Black	40 lb	2.000"	.469"	.500"	2.000"	.257"	1.000"	1.000"	.257"	.469"	.167"	.167"	.078"	.040 lb
2085	15 RT	Clear	70 lb	3.000"	.686"	.750"	3.000"	.328"	1.500"	1.500"	.328"	.686"	.250"	.250"	.125"	.135 lb
2085-Black	15 RT	Black	70 lb	3.000"	.686"	.750"	3.000"	.328"	1.500"	1.500"	.328"	.686"	.250"	.250"	.125"	.135 lb
2084	10 to 15	Clear	75 lb	2.500"	.375"	.750"	3.000"	.257"	1.000"	1.500"	.328"	.750"	.250"	.250"	.125"	.118 lb
2084-Black	10 to 15	Black	75 lb	2.500"	.375"	.750"	3.000"	.257"	1.000"	1.500"	.328"	.750"	.250"	.250"	.125"	.118 lb
25-2086	25	Clear	18 kg	50.80mm	11.91mm	12.70mm	50.80mm	6.53mm	25.40mm	25.40mm	6.53mm	11.91mm	4.23mm	4.23mm	1.98mm	.0236 kg
25-2086-Black	25	Black	18 kg	50.80mm	11.91mm	12.70mm	50.80mm	6.53mm	25.40mm	25.40mm	6.53mm	11.91mm	4.23mm	4.23mm	1.98mm	.0236 kg
40-2085	40	Clear	34 kg	76.20mm	17.42mm	19.05mm	76.20mm	8.33mm	38.10mm	38.10mm	8.33mm	17.42mm	6.35mm	6.35mm	3.18mm	.0640 kg
40-2085-Black	40	Black	34 kg	76.20mm	17.42mm	19.05mm	76.20mm	8.33mm	38.10mm	38.10mm	8.33mm	17.42mm	6.35mm	6.35mm	3.18mm	.0640 kg
65-2084	25 to 40	Clear	34 kg	63.50mm	9.53mm	19.05mm	76.20mm	6.53mm	25.40mm	38.10mm	8.33mm	19.05mm	6.35mm	6.35mm	3.18mm	.0542 kg
65-2084-Black	25 to 40	Black	34 kg	63.50mm	9.53mm	19.05mm	76.20mm	6.53mm	25.40mm	38.10mm	8.33mm	19.05mm	6.35mm	6.35mm	3.18mm	.0542 kg

*The gap distance between profiles for 10 series is .062", 15 series is .120", 25 series is 1.97mm, 40 series is 1.15mm and for series transitions is .125" (2.42mm).

Material Specifications

Material	Leaf Alloy	Pin Alloy	Finish	Process
Aluminum	5052-H32/34	6061-T6	Anodize	Die Stamping

Suggested Hardware (Mount to T-Slot)

Part No.	Series	Qty.	Bolt	Nut Type	Washer
3386	10	4	1/4-20 x 3/8 FBHSCS	Economy T-Nut	—
3319	15	4	5/16-18 x 1/2 FBHSCS	Economy T-Nut	—
3386	10 to 15	2	1/4-20 x 3/8 FBHSCS	Economy T-Nut	—
3319		2	5/16-18 x 1/2 FBHSCS	Economy T-Nut	—
75-3515	25	4	M6 x 10mm BHSCS	Economy T-Nut	—
75-3525	40	4	M8 x 12mm BHSCS	Economy T-Nut	—
75-3515	25 to 40	2	M6 x 10mm BHSCS	Economy T-Nut	—
75-3525		2	M8 x 12mm BHSCS	Economy T-Nut	—
3961	OR	4	5/16-18 x 2.000" BHSCS	Flanged Hex Nut	3760
3964		4	M8 X 50mm BHSCS	Flanged Hex Nut	3860

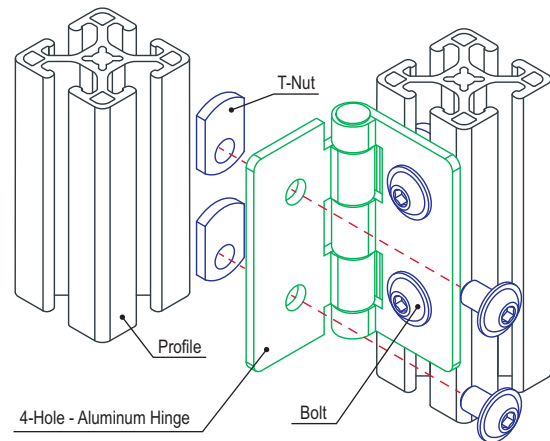

2 Hole - Standard Plastic Hinge

Part Description:

The 2 hole - standard plastic hinge is made of fiberglass-reinforced black nylon with a stainless steel pin. It is commonly used to connect plastic panels and lightweight doors to T-slot profiles.

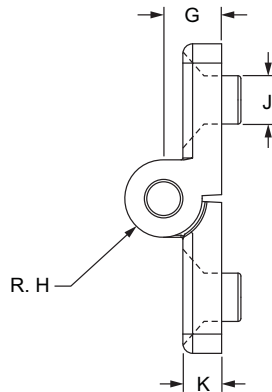
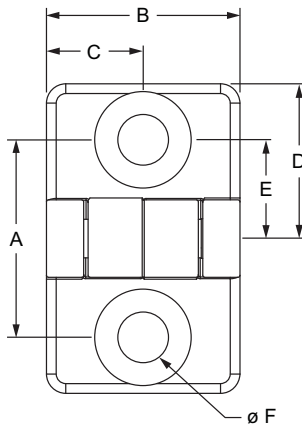

Part No.	Series	Max Load	A	B	C	D	E	F	G	H	J	K	Weight
12074	20	10 Nm / 7.3 ft-Lbs.	20.40mm	20.00mm	10.00mm	16.00mm	10.20mm	5.20mm	6.00mm	4.00mm	—	4.00mm	.0063 kg
12075	20		20.40mm	20.00mm	10.00mm	16.00mm	10.20mm	5.20mm	6.00mm	4.00mm	5.00mm	4.00mm	.0063 kg
12252	45		50.00mm	40.00mm	20.00mm	45.00mm	25.00mm	6.50mm	9.00mm	8.00mm	10.00mm	8.50mm	.0471 kg

Material Specifications

Part No.	Material	Grade	Color	Process
12074	Nylon PA Glass Fiber Reinforced	PA6GF30	Black	Injection Molding
12075			Black	
12252			Black/Bolt Plain	

Suggested Hardware Per Leaf (Mount to T-Slot)

Part No.	Series	Qty.	Bolt	T-Nut
75-3571	20	1	M5 x 8mm FHSCS	Economy
75-3588	45	1	M6 x 20mm FHSCS	Drop-in

Suggested Hardware Per Leaf (Mount to Panel ≤ .250" / 6mm)

Part No.	Series	Qty.	Bolt	Hex Nut	Washer
75-3573	20	1	M5 x 14mm FHSCS	Yes	Yes
75-3589	45	1	M6 x 20mm FHSCS	Yes	Yes

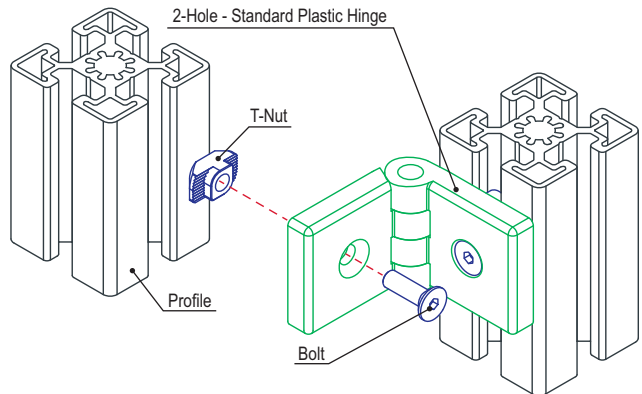

4 Hole - Standard Plastic Hinge

Part Description:

The 4 hole - standard plastic hinge is made of fiberglass-reinforced black nylon with a stainless steel pin. It is commonly used to connect plastic panels and lightweight doors to T-slot profiles.

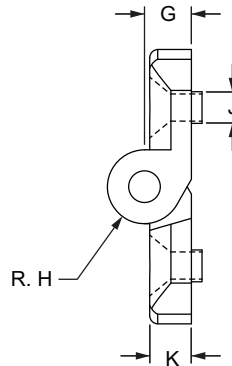
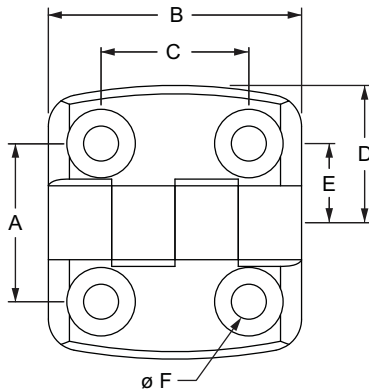

Part No.	Series	Material	Color	Process	Max Load	A	B	C	D	E	F	G	H	J	K	Weight
12067	20	Nylon PA Glass Fiber Reinforced	Black	Injection Molding	30 Nm / 22 ft-Lbs.	23.00mm	30.00mm	14.00mm	19.50mm	11.50mm	4.50mm	5.50mm	4.00mm	—	5.00mm	.0077 kg
12098	10 25					30.00mm	48.00mm	28.00mm	26.00mm	15.00mm	6.60mm	8.95mm	7.00mm	—	7.40mm	.0336 kg
12099	10 25					30.00mm	48.00mm	28.00mm	26.00mm	15.00mm	6.60mm	8.90mm	7.00mm	6.00mm	7.90mm	.0321 kg
12107	30					35.00mm	48.00mm	28.00mm	29.50mm	17.50mm	6.60mm	8.90mm	7.00mm	—	8.40mm	.0353 kg
12108	30					35.00mm	48.00mm	28.00mm	29.50mm	17.50mm	6.60mm	8.90mm	7.00mm	7.76mm	8.20mm	.0336 kg
12116	15					40.00mm	48.00mm	28.00mm	35.50mm	20.00mm	6.40mm	9.00mm	7.00mm	—	8.00mm	.0392 kg
12117	15				40.00mm	48.00mm	28.00mm	35.50mm	20.00mm	6.60mm	8.90mm	7.00mm	8.00mm	7.90mm	.0396 kg	
12125	15 40				40 Nm / 30 ft-Lbs.	45.00mm	48.00mm	28.00mm	38.50mm	22.50mm	6.60mm	8.90mm	7.00mm	—	7.40mm	.0404 kg
12126	15 40				45.00mm	48.00mm	28.00mm	38.50mm	22.50mm	6.60mm	8.90mm	7.00mm	7.76mm	7.90mm	.0404 kg	
12134	45				40 Nm / 29 ft-Lbs.	50.00mm	48.00mm	28.00mm	43.50mm	25.00mm	6.60mm	8.90mm	7.00mm	7.76mm	7.70mm	.0467 kg
12136	45				50.00mm	48.00mm	28.00mm	43.50mm	25.00mm	6.60mm	8.90mm	7.00mm	9.72mm	7.90mm	.0467 kg	

*The gap distance between profiles is .075" (1.90mm)

Suggested Hardware Per Leaf (Mount to T-Slot)

Part No.	Series	Qty.	Bolt	T-Nut
3419	10	2	1/4-20 x 1/2 FHSCS	Economy
3409	15	2	1/4-20 x 5/8 FHSCS	Drop-in
75-3552	20	2	M4 x 10mm FHSCS	Economy
75-3616	25	2	M6 x 14mm FHSCS	Economy
75-3585	30	2	M6 x 14mm FHSCS	Drop-in
75-3628	40	2	M6 x 18mm FHSCS	Drop-in
75-3587	45	2	M6 x 18mm FHSCS	Drop-in

Suggested Hardware Per Leaf (Mount to Panel ≤ .250" / 6mm)

Part No.	Series	Qty.	Bolt	Hex Nut	Washer
3417	10 15	2	1/4-20 x 3/4 FHSCS	Yes	Yes
75-3562	20	2	M4 x 12mm FHSCS	Yes	Yes
75-3589	25 30 40 45	2	M6 x 20mm FHSCS	Yes	Yes

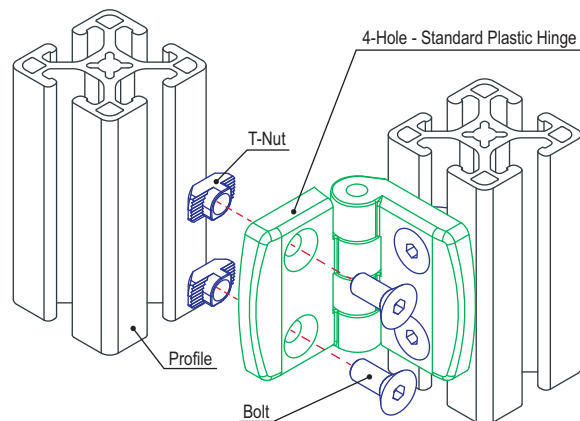

4 Hole - Horizontal Adjustment Plastic Hinge

Part Description:

The 4 hole - horizontal adjustment plastic hinge is made of fiberglass-reinforced black nylon with a stainless steel pin. It is commonly used to connect plastic panels and lightweight doors to T-slot profiles. It has horizontally slotted holes to support adjustments. The suggested hardware to mount the hinge to a T-slot profile can be found below.

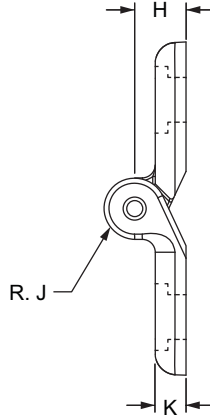
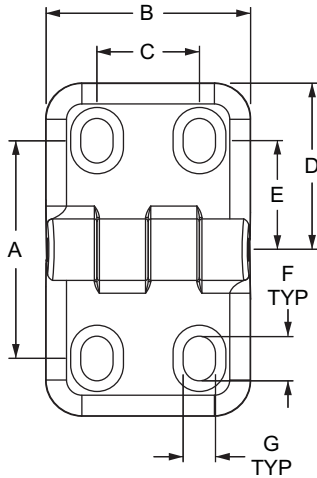

Part No.	Series	Max Load	A	B	C	D	E	F	G	H	J	K	Weight
12254	15 40	17 Nm / 12.5 ft-Lbs.	42.50mm	40.00mm	20.00mm	32.50mm	21.25mm	8.70mm	6.20mm	10.00mm	6.00mm	6.00mm	.0232 kg

Material Specifications

Material	Grade	Color	Process
Nylon PA Glass Fiber Reinforced	PA6GF30	Black/Bolt Plain	Injection Molding

Suggested Hardware Per Leaf (Mount to T-Slot)

Part No.	Series	Qty.	Bolt	T-Nut
3418	15	2	1/4-20 x 5/8 BHSCS	Economy
75-3622	40	2	M6 x 14mm BHSCS	Drop-in

Suggested Hardware Per Leaf (Mount to Panel ≤ .250" / 6mm)

Part No.	Series	Qty.	Bolt	Hex Nut	Washer
3469	15	2	1/4-20 x 3/4 BHSCS	Yes	Yes
75-3605	40	2	M6 x 18mm BHSCS	Yes	Yes

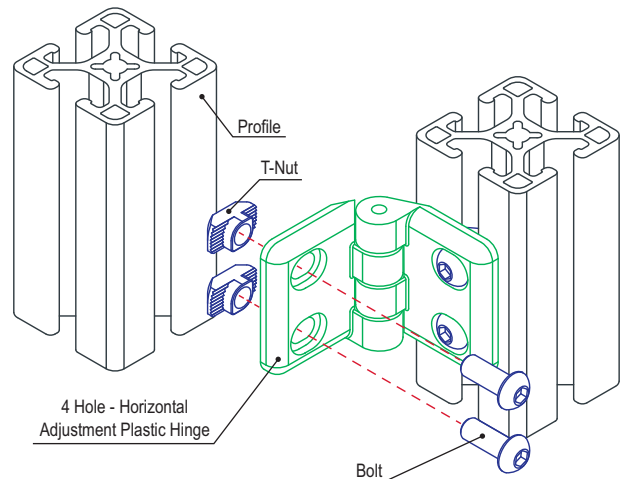

80/20[®] inc. 4 Hole - Standard Plastic Hinge with Snap Cover

Part Description:

The 4 hole - standard plastic hinge with snap cover is made of fiberglass-reinforced black nylon with a die-cast zinc pin. It has a snap-on cover that hides the mounting hardware to provide a clean look. It is commonly used to connect plastic panels and lightweight doors to T-slot profiles. The suggested hardware to mount the hinge to a T-slot profile can be found below.

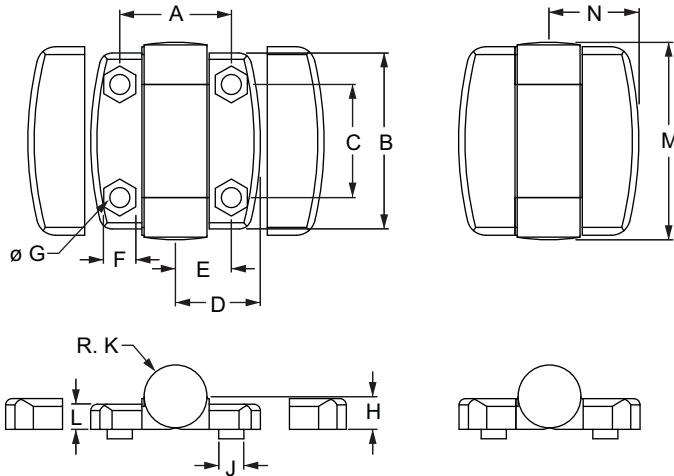

Part No.	Series	Max Load	A	B	C	D	E	F	G	H	J	K	L	M	N	Weight
12162	30	20 Nm / 14.7 ft-Lbs.	35.50mm	56.00mm	36.00mm	27.00mm	17.75mm	10.20mm	6.40mm	10.50mm	—	20.00mm	8.00mm	62.80mm	28.80mm	.0327 kg
12164	30		35.50mm	56.00mm	36.00mm	27.00mm	17.75mm	10.20mm	6.40mm	10.50mm	8.00mm	20.00mm	8.00mm	62.80mm	28.80mm	.0335 kg
12165	15 40		45.50mm	56.00mm	36.00mm	36.75mm	22.75mm	10.20mm	6.40mm	10.50mm	—	20.00mm	8.00mm	62.80mm	38.60mm	.0549 kg
12166	15 40		45.50mm	56.00mm	36.00mm	36.75mm	22.75mm	10.20mm	6.40mm	10.50mm	8.00mm	20.00mm	8.00mm	62.80mm	38.60mm	.0422 kg

Material Specifications

Material	Grade	Color	Process
Nylon PA Glass Fiber Reinforced	PA6GF30	Black	Injection Molding

Suggested Hardware Per Leaf (Mount to T-Slot)

Part No.	Series	Qty.	Bolt	T-Nut
3418	15	2	1/4-20 x 5/8 BHSCS	Economy
75-3599	30	2	M6 x 10mm BHSCS	Drop-in
75-3622	40	2	M6 x 14mm BHSCS	Drop-in

Suggested Hardware Per Leaf (Mount to Panel ≤ .250" / 6mm)

Part No.	Series	Qty.	Bolt	Hex Nut	Washer
3469	15	2	1/4-20 x 3/4 BHSCS	Yes	Yes
75-3603	30	2	M6 x 14mm BHSCS	Yes	No
75-3605	40	2	M6 x 18mm BHSCS	Yes	Yes

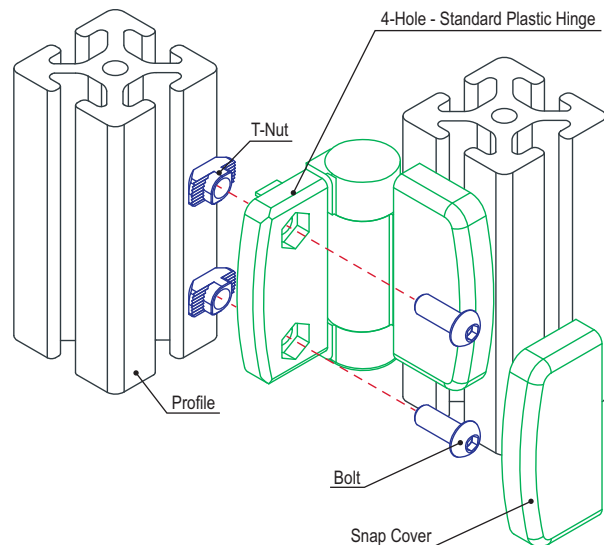

4 Hole - Economy Zinc Hinge

Part Description:

The 4 hole - economy zinc hinge is made of die-cast zinc with a black powder coat finish. It is a higher-strength hinge that is commonly used to connect doors and plastic panels to T-slot profiles. The suggested hardware to mount the hinge to a T-slot profile can be found below.

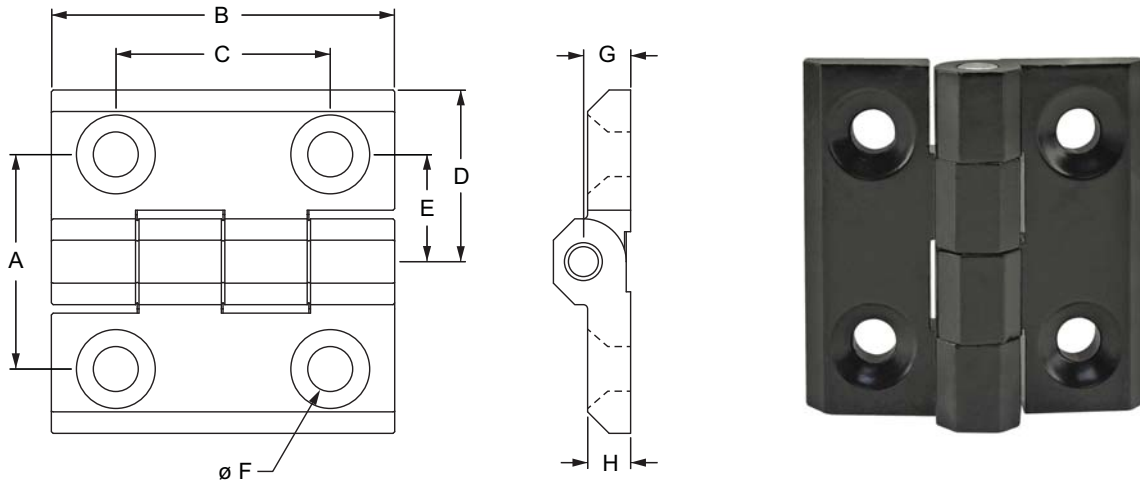

Part No.	Series	Max Load	A	B	C	D	E	F	G	H	Weight
12255	20	50 Nm / 36.8 ft-Lbs.	25.00mm	40.00mm	25.00mm	20.00mm	12.50mm	5.20mm	5.50mm	5.00mm	.0465 kg
12256	10 25	50 Nm / 36.8 ft-Lbs.	30.00mm	50.00mm	30.00mm	25.00mm	15.00mm	6.30mm	6.50mm	6.00mm	.0920 kg
12062	30	60 Nm / 44.0 ft-Lbs.	36.00mm	60.00mm	36.00mm	30.00mm	18.00mm	8.30mm	8.00mm	8.00mm	.1153 kg

Material Specifications

Material	Grade	Finish	Process
Zinc	Die-Cast	Black Powder Coat	Die-Casting

Suggested Hardware Per Leaf (Mount to T-Slot)

Part No.	Series	Qty.	Bolt	T-Nut
3414	10	2	1/4-20 x 1/2 FHSCS	Economy
75-3572	20	2	M5 x 10mm FHSCS	Economy
75-3584	25	2	M6 x 14mm FHSCS	Slide-in
75-3585	30	2	M6 x 14mm FHSCS	Drop-in

Suggested Hardware Per Leaf (Mount to Panel ≤ .250" / 6mm)

Part No.	Series	Qty.	Bolt	Hex Nut	Washer
11-5716	20	2	M5 x 16mm FHSCS	11-5065	11-6040
11-6718	10 25	2	M6 x 18mm FHSCS	11-6065	11-6041
11-8716	30	2	M8 x 18mm FHSCS	11-8065	11-6042

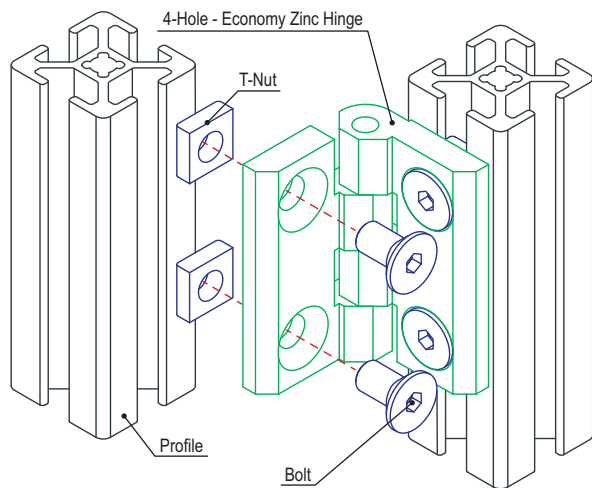

Part Description:

The 4 hole - transition hinge is available in stainless steel or black powder-coat zinc. It is commonly used to mount larger doors or two profiles. This hinge can be used as a transition from 30 to 45 series profiles and can be easily assembled with the suggested mounting hardware listed below.

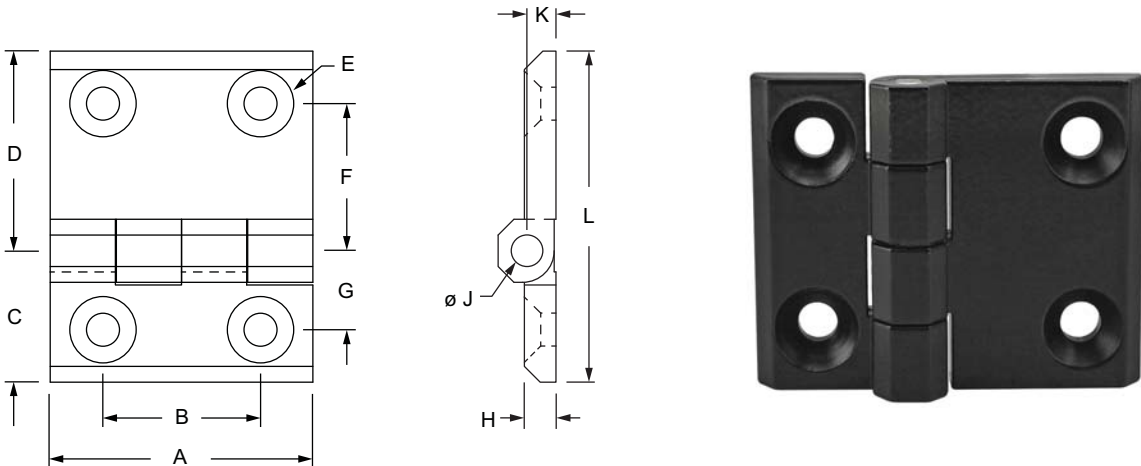

Part No.	Series	Max Load	A	B	C	D	E	F	G	H	J	K	L	Weight
12064	30 to 45	60 Nm /	50.00mm	30.00mm	25.00mm	38.00mm	M6 FHSCS	28.00mm	15.00mm	6.00mm	6.00mm	6.00mm	63.00mm	.1049 kg
12065	30 to 45	44 ft-Lbs.	50.00mm	30.00mm	25.00mm	38.00mm	M6 FHSCS	28.00mm	15.00mm	6.00mm	6.00mm	6.00mm	63.00mm	.1283 kg

Material Specifications

Part No.	Material	Grade	Finish	Process
12064	Zinc	Zn Al Cu 1	Black Powder Coat	Die-Casting
12065	Stainless-Steel	316	Stainless	Die-Casting

Suggested Hardware Per Leaf (Mount to T-Slot)

Part No.	Series	Qty.	Bolt	T-Nut
75-3585	30 AND 45	2	M6 x 14mm FHSCS	Drop-In
75-3587	45	2	M6 x 18mm FHSCS	Drop-In

Suggested Hardware Per Leaf (Mount to Panel ≤ .250" / 6mm)

Part No.	Series	Qty.	Bolt	Hex Nut	Washer
11-6718	30 45	2	M6 x 18mm FHSCS	11-6065	11-6041

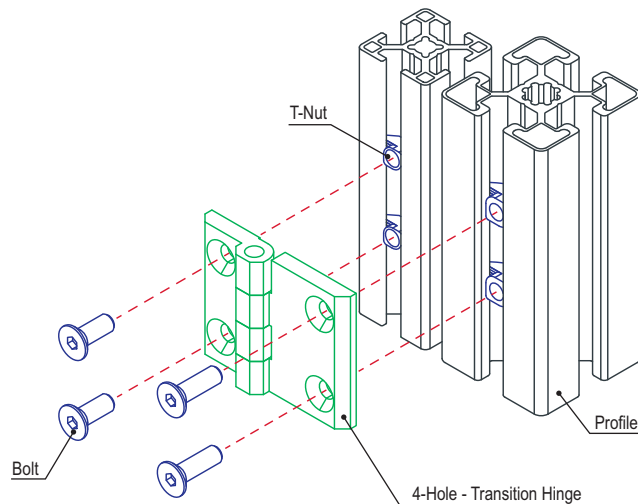

4 Hole - Standard Stainless Steel Hinge

Part Description:

The 4 hole - standard stainless steel hinge is made of stainless steel. It is a higher-strength hinge that is commonly used to connect doors and plastic panels to T-slot profiles. The suggested hardware to mount the hinge to a T-slot profile can be found below.

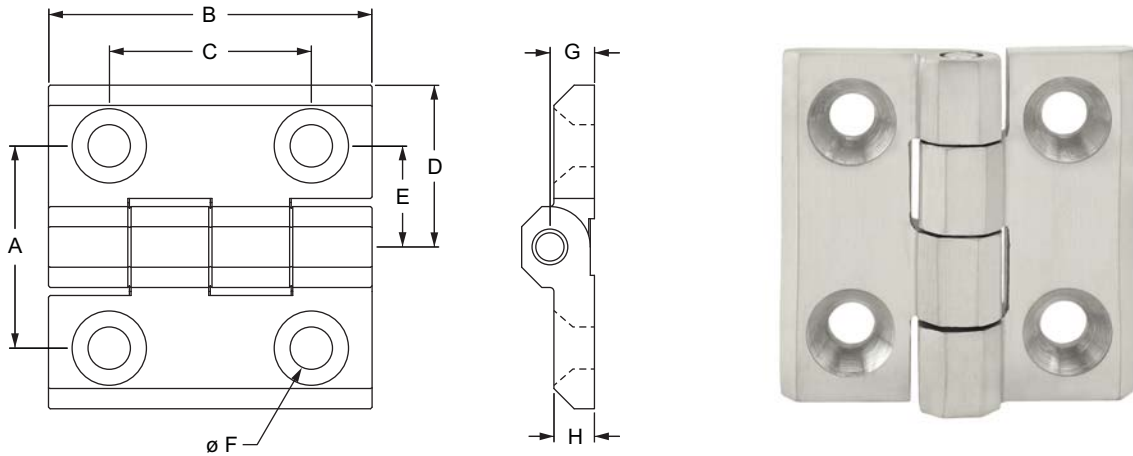

Part No.	Series	Max Load	A	B	C	D	E	F	G	H	Weight
12093	20	50 Nm / 36.8 ft-Lbs.	25.00mm	40.00mm	25.00mm	20.00mm	12.50mm	5.20mm	5.50mm	5.00mm	.0539 kg
12094	10 25	50 Nm / 36.8 ft-Lbs.	30.00mm	50.00mm	30.00mm	25.00mm	15.00mm	6.30mm	6.50mm	6.00mm	.0970 kg
12096	30	60 Nm / 44.0 ft-Lbs.	36.00mm	60.00mm	36.00mm	30.00mm	18.00mm	8.30mm	8.00mm	8.00mm	.0952 kg

Material Specifications

Material	Finish	Process
Stainless-Steel	Stainless	Machined

Suggested Hardware Per Leaf (Mount to T-Slot)

Part No.	Series	Qty.	Bolt	T-Nut
3639	10	2	1/4-20 x 1/2 FHSCS	Standard
75-3572	20	2	M5 x 10mm FHSCS	Economy
75-3639	25	2	M6 x 12mm FHSCS	Standard
75-3585	30	2	M6 x 14mm FHSCS	Drop-in

Suggested Hardware Per Leaf (Mount to Panel ≤ .250" / 6mm)

Part No.	Series	Qty.	Bolt	Hex Nut	Washer
11-5716	20	2	M5 x 16mm FHSCS	11-5065	11-6040
11-6718	10 25	2	M6 x 18mm FHSCS	11-6065	11-6041
11-8720	30	2	M8 x 20mm FHSCS	11-8065	11-6042

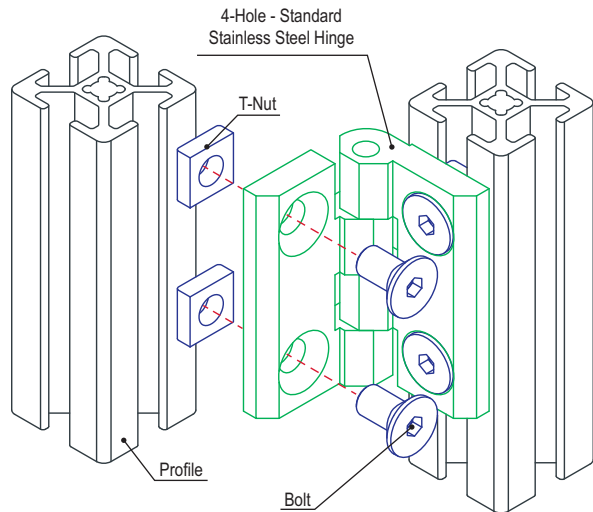

Part Description:

The 4 hole - zinc hinge is die-cast black powder-coated zinc with a stainless steel pin. It is a higher-strength hinge that is commonly used to connect doors and plastic panels to T-slot profiles. The suggested hardware to mount the hinge to a T-slot profile can be found below.

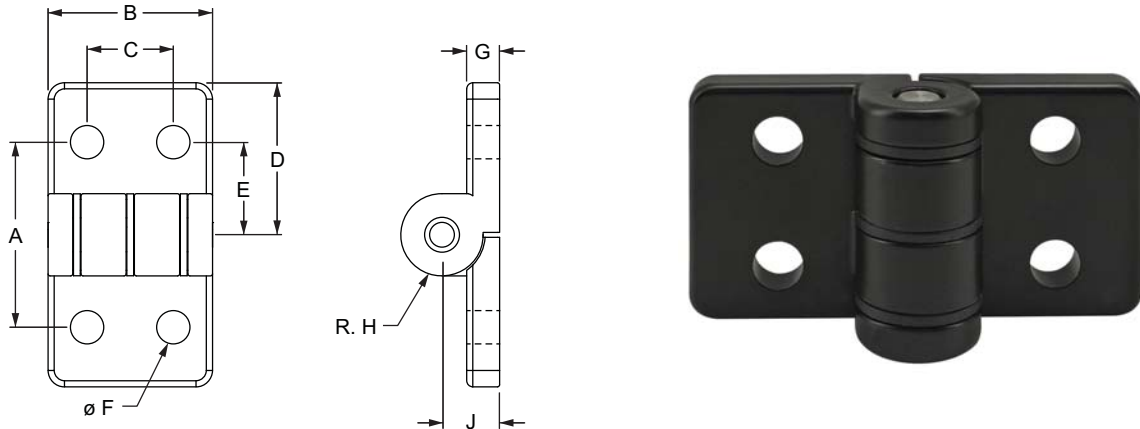

Part No.	Series	A	B	C	D	E	F	G	H	J	Weight
4489	15	1.771"	1.574"	.826"	1.457"	.885"	.323"	.314"	.393"	.551"	.426 lb
40-4489	40	45.00mm	40.00mm	21.00mm	37.00mm	22.50mm	8.20mm	8.00mm	10.00mm	14.00mm	.1940 kg

Material Specifications

Material	Grade	Finish	Process
Zinc	Die-Cast	Black Powder Coat	Die-Casting

Suggested Hardware Per Leaf (Mount to T-Slot)

Series	Part No.	Qty.	Bolt	Part No.	Qty.	T-Nut
15	3114	2	5/16-18 x 3/4 BHSCS	3203	2	Standard
40	11-8518	2	M8 x 18mm SHCS	40-1984	2	Standard

Suggested Hardware Per Leaf (Mount to Panel ≤ .250" / 6mm)

Part No.	Series	Qty.	Bolt	Hex Nut	Washer
3117	15	2	5/16-18 x 7/8 BHSCS	3214	3260
11-8320	40	2	M8 x 20mm BHSCS	11-8065	11-6042

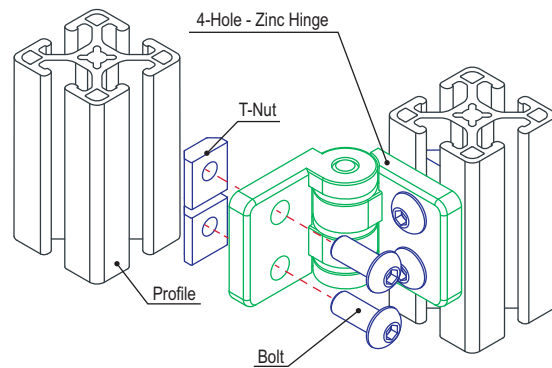

4 Hole - Locking Zinc Hinge

Part Description:

The 4 hole - locking zinc hinge is die-cast black powder-coated zinc with a stainless steel pin. It is a higher-strength hinge that is commonly used to connect doors and plastic panels to T-slot profiles. The 4 hole - locking zinc hinge features a ratcheting clamp handle for locking the hinge in position. The suggested hardware to mount the hinge to a T-slot profile can be found below.

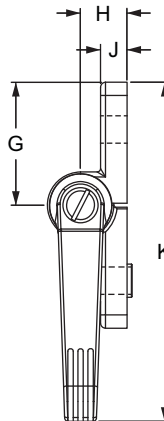
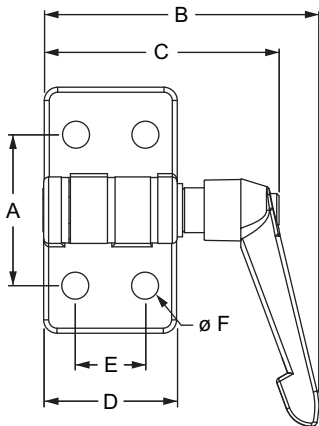

Part No.	Series	A	B	C	D	E	F	G	H	J	K	Weight
4488	15	1.771"	3.252"	2.780"	1.574"	.827"	.323"	1.457"	.551"	.315"	4.016"	.499 lb
40-4488	40	45.40mm	82.60mm	70.60mm	40.00mm	21.00mm	8.20mm	37.00mm	14.00mm	8.00mm	102.00mm	.2280 kg

Material Specifications

Material	Grade	Finish	Process
Zinc	Die-Cast	Black Powder Coat	Die-Casting

Suggested Hardware Per Leaf (Mount to T-Slot)

Series	Part No.	Qty.	Bolt	Part No.	Qty.	T-Nut
15	3114	2	5/16-18 x 3/4 BHSCS	3203	2	Standard
40	11-8518	2	M8 x 18mm SHCS	40-1984	2	Standard

Suggested Hardware Per Leaf (Mount to Panel ≤ .250" / 6mm)

Part No.	Series	Qty.	Bolt	Hex Nut	Washer
3117	15	2	5/16-18 x 7/8 BHSCS	3214	3260
11-8320	40	2	M8 x 20mm BHSCS	11-8065	11-6042

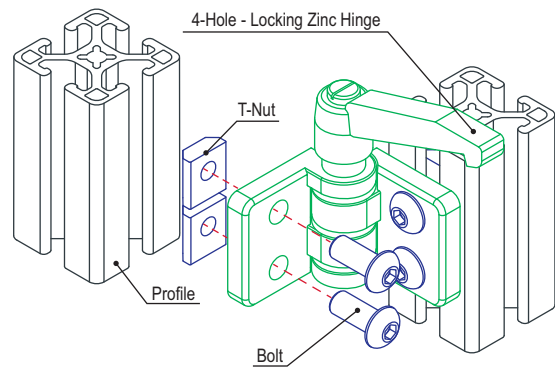

4 Hole - Slotted Zinc Hinge

Part Description:

The 4 hole - slotted zinc hinge is die-cast black powder-coated zinc with a stainless steel pin. It is a higher-strength hinge that is commonly used to connect doors and plastic panels to T-slot profiles. The hinge has slotted holes to support adjustments and is available in options with slot tabs to assist with alignment. The suggested hardware to mount the hinge to a T-slot profile can be found below.

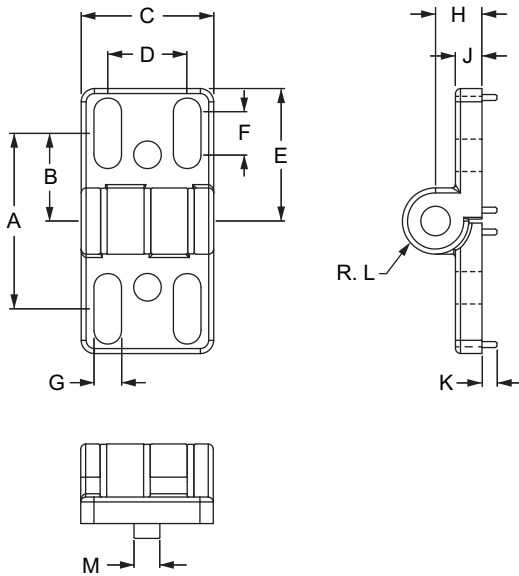

Part No.	Series	Max Load	A	B	C	D	E	F	G	H	J	K	L	M	Weight
12084	15 40 45	250 Nm / 184 ft-Lbs.	53.00mm	26.50mm	40.00mm	24.00mm	40.00mm	13.00mm	8.30mm	14.00mm	8.00mm	—	10.00mm	—	.1816 kg
12088	15 40		53.00mm	26.50mm	40.00mm	24.00mm	40.00mm	13.00mm	8.30mm	14.00mm	8.00mm	4.50mm	10.00mm	7.80mm	.1679 kg
12089	45		53.00mm	26.50mm	40.00mm	24.00mm	40.00mm	13.00mm	8.30mm	14.00mm	8.00mm	4.50mm	10.00mm	9.80mm	.1866 kg

Material Specifications

Material	Grade	Finish	Process
Zinc	Die-Cast	Black Powder Coat	Die-Casting

Suggested Hardware Per Leaf (Mount to T-Slot)

Part No.	Series	Qty.	Bolt	T-Nut
3455	15	2	5/16-18 x 3/4 SHCS	Economy
75-3627	40	2	M8 x 18mm SHCS	Slide-in
75-3630	45	2	M8 x 20mm SHCS	Drop-in

Suggested Hardware Per Leaf (Mount to Panel ≤ .250" / 6mm)

Part No.	Series	Qty.	Bolt	Hex Nut	Washer
3117	15	2	5/16-18 x 7/8 BHSCS	3214	3260
11-8320	40 45	2	M8 x 20mm BHSCS	11-8065	11-6042

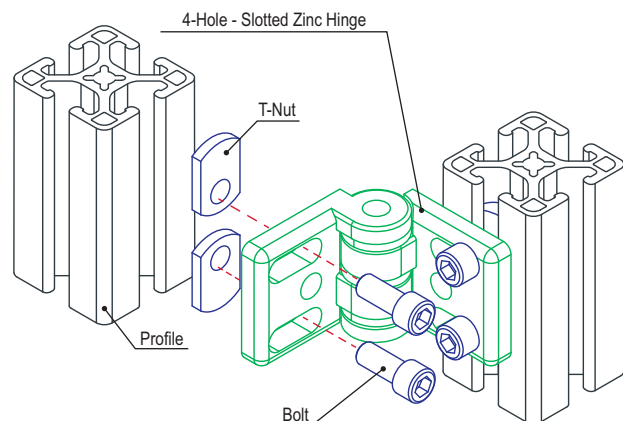

4 Hole - Slotted Locking Zinc Hinge

Part Description:

The 4 hole - slotted locking zinc hinge is die-cast black powder-coated zinc with a stainless steel pin. It is a higher-strength hinge that is commonly used to connect doors and plastic panels to T-slot profiles. The hinge has slotted holes to support adjustments and a ratcheting clamp handle for locking the hinge in position. It also features slot tabs to assist with alignment. The suggested hardware to mount the hinge to a T-slot profile can be found below.

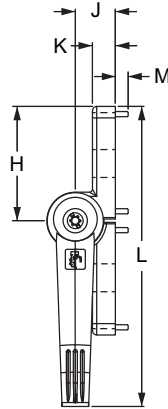
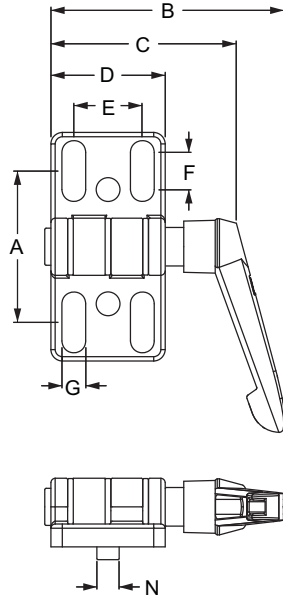

Part No.	Series	Max Load	A	B	C	D	E	F	G	H	J	K	L	M	N	Weight
12085	15 40 45	250 Nm / 184 ft-Lbs.	53.00mm	81.00mm	69.00mm	40.00mm	24.00mm	13.00mm	8.30mm	40.00mm	14.00mm	8.00mm	105.00mm	—	—	.2155 kg
12086	15 40		53.00mm	81.60mm	65.00mm	40.00mm	24.00mm	13.00mm	8.30mm	40.00mm	14.00mm	8.00mm	105.00mm	4.50mm	7.80mm	.2132 kg
12087	45		53.00mm	81.00mm	69.00mm	40.00mm	24.00mm	13.00mm	8.30mm	40.00mm	14.00mm	8.00mm	105.00mm	4.50mm	10.00mm	.2092 kg

Material Specifications

Material	Grade	Finish	Process
Zinc	Die-Cast	Black Powder Coat	Die-Casting

Suggested Hardware Per Leaf (Mount to T-Slot)

Part No.	Series	Qty.	Bolt	T-Nut
3455	15	2	5/16-18 x 3/4 SHCS	Economy
75-3627	40	2	M8 x 18mm SHCS	Slide-in
75-3630	45	2	M8 x 20mm SHCS	Drop-in

Suggested Hardware Per Leaf (Mount to Panel ≤ .250" / 6mm)

Part No.	Series	Qty.	Bolt	Hex Nut	Washer
3117	15	2	5/16-18 x 7/8 BHSCS	3214	3260
11-8320	40 45	2	M8 x 20mm BHSCS	11-8065	11-6042

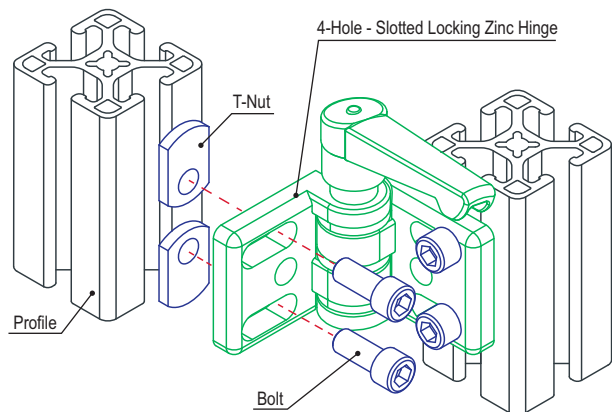

Part Description:

The lite panel hinge is made of steel with a black powder coat. It is a cost-effective option that is commonly used to mount plastic panel doors and lightweight T-slot profiles. The slotted holes allow for greater adjustability when positioning the hinge. It includes the bolt assembly to mount to a .250" (6mm) panel. The suggested hardware to mount to a T-slot profile can be found below.

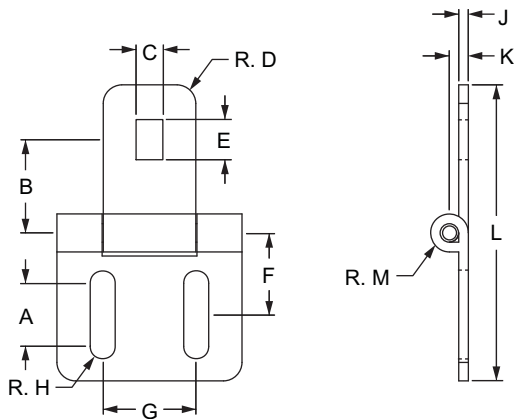

Part No.	Series	Max Load	A	B	C	D	E	F	G	H	J	K	L	M	Weight
12097	15 40	25 Nm / 18.0 ft-Lbs.	13.60mm	20.15mm	6.80mm	4.00mm	8.70mm	17.70mm	20.20mm	2.70mm	4.10mm	2.10mm	64.00mm	4.10mm	.0526 kg

Material Specifications

Material	Grade	Finish	Process
Steel	Die-Cast	Black Powder Coat	Die-Casting

Included Hardware (Mount to Panel \leq .250" / 6mm)

Series	Qty.	Bolt	Qty.	T-Nut	Qty.	Washer
15 40	4	M5 Screw	1	M5 Hex Nut	1	M5 Washer

Suggested Hardware (Mount to T-Slot)

Part No.	Series	Qty.	Bolt	T-Nut
3487	15	2	10-32 x 1/2 BHSCS	Slide-in
75-3583	40	2	M5 x 12mm BHSCS	Drop-in

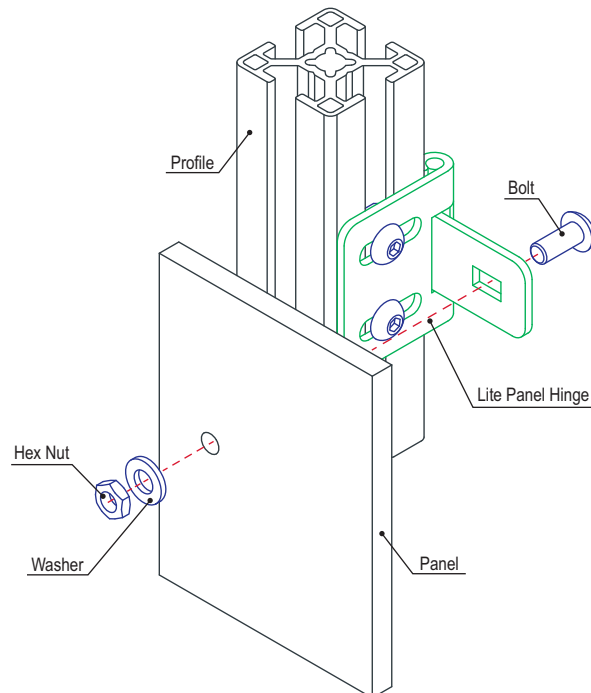

Plastic Door Handle



Part Description:

The plastic door handle is made of light yet durable high-strength glass-filled nylon. It is corrosion-resistant, lending it to both indoor and outdoor applications. The plastic door handle is designed to mount directly to a T-slot profile or can also be used with a plastic panel. See below for the suggested mounting hardware.

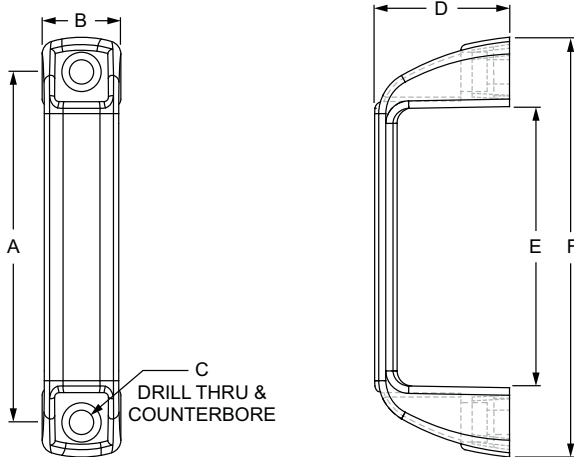

Part No.	Series	Material	Finish	Process	Color	A	B	C	D	E	F	Weight
2062	10	Glass-Filled Nylon	Textured	Molded	Black	3.681"	.827"	1/4	1.417"	2.953"	4.409"	.048 lb
2882	10				Red	3.681"	.827"	1/4	1.417"	2.953"	4.409"	.060 lb
2061	15				Black	4.606"	1.024"	5/16	1.614"	3.779"	5.472"	.079 lb
2881	15				Red	4.606"	1.024"	5/16	1.614"	3.779"	5.472"	.093 lb
2060	15				Black	7.047"	1.102"	5/16	1.969"	6.181"	8.189"	.178 lb
2880	15				Red	7.047"	1.102"	5/16	1.969"	6.181"	8.189"	.168 lb
25-2062	25 30				Black	93.50mm	21.00mm	M6	36.00mm	75.00mm	112.00mm	.0213 kg
25-2882	25 30				Red	93.50mm	21.00mm	M6	36.00mm	75.00mm	112.00mm	.0273 kg
40-2061	40				Black	117.00mm	26.00mm	M8	41.00mm	96.00mm	139.00mm	.0262 kg
40-2881	40				Red	117.00mm	26.00mm	M8	41.00mm	96.00mm	139.00mm	.0426 kg
40-2060	40				Black	179.00mm	28.00mm	M8	50.00mm	157.00mm	208.00mm	.0812 kg
40-2880	40				Red	179.00mm	28.00mm	M8	50.00mm	157.00mm	208.00mm	.0749 kg

Suggested Hardware (Mount to T-Slot)

Part No.	Series	Qty.	Bolt	T-Nut
3491	10	2	1/4-20 x 1/2" SHCS	Economy
3455	15	2	5/16-18 x 3/4" SHCS	Economy
75-3521	25 30	2	M6 x 12mm SHCS	Economy
75-3634	40	2	M8 x 18mm SHCS	Economy

Suggested Hardware (Mount to Panel ≤ .250" / 6mm)

Part No.	Series	Qty.	Bolt	T-Nut
3315	10	2	1/4-20 x 7/8" SHCS & Washer	Hex Nut
3473	15	2	5/16-18 x 1" SHCS & Washer	Hex Nut
75-3470	25 30	2	M6 x 16mm SHCS & Washer	Hex Nut
75-3475	40	2	M8 x 20mm SHCS & Washer	Hex Nut

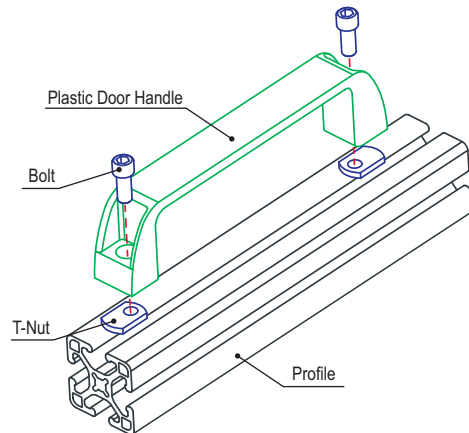

PANELS & DOORS

Part Description:

The offset plastic handle is made of fiberglass-reinforced nylon that is corrosion-resistant making it useful for both indoor and outdoor applications. It bolts directly to the T-slot profile and is ideal for bi-fold doors. One side is completely solid to prevent finger pinching and there is an orange snap-on cover included to hide the mounting screws and provide a clean look. All mounting hardware is included.

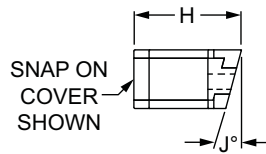
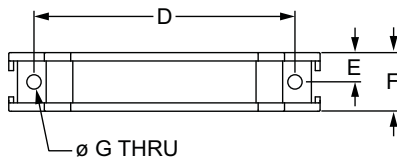
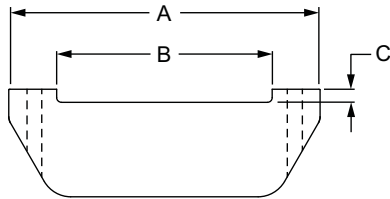

Part No.	Series	Body Color	Cover Color	A	B	C	D	E	F	G	H	J	Weight
2079	10 15	Black	Orange	5.078"	3.543"	.217"	4.291"	.482"	.964"	.236"	1.767"	15°	.196 lb
40-2079	25 30 40			129.00mm	90.00mm	5.50mm	109.00mm	12.25mm	24.50mm	6.00mm	44.90mm	15°	.0826 kg

Material Specifications

Material	Finish	Process
Fiberglass-Reinforced Nylon	Matte	Molded

Included Hardware (Mount to T-Slot)

Part No.	Series	Qty.	Bolt	T-Nut
75-3802	10	2	1/4-20 x 5/8 BHSCS	Economy
75-3804	15	2	1/4-20 x 3/4 BHSCS	Economy
75-3406	25 30	2	M6 x 16mm BHSCS	Economy
75-3407	40	2	M6 x 20mm BHSCS	Economy

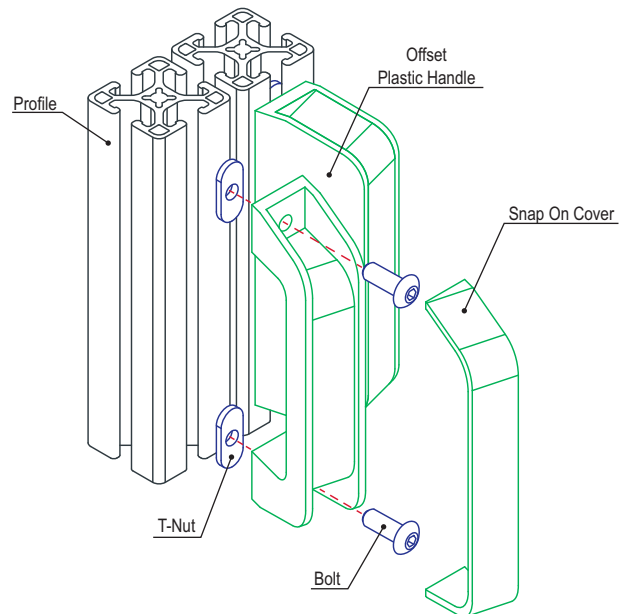

Ergonomic Plastic Handle

Part Description:

The ergonomic plastic handle is made of durable yet lightweight fiberglass-reinforced nylon. It is corrosion-resistant, lending it to both indoor and outdoor applications. The handle has an easy to grip design and an offset, closed side for finger protection. The ergonomic plastic handle mounts directly to a T-slot profile.

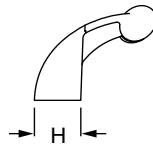
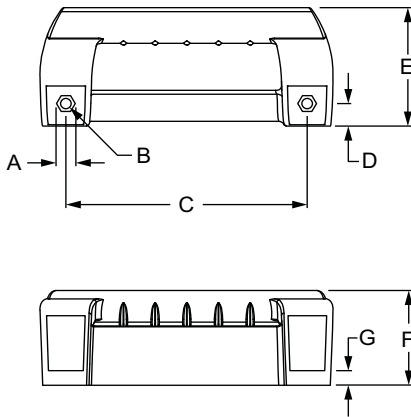

Part No.	Series	Material	Process	Color	A	B	C	D	E	F	G	H	Weight
12000	15 40 45	Nylon PA	Injection Molded	Black	16.00mm	8.70mm	198.00mm	19.00mm	100.00mm	80.00mm	12.50mm	38.00mm	.0762 kg

Suggested Hardware (Mount to T-Slot)

Part No.	Series	Qty.	Bolt	T-Nut
3454	15	2	5/16-18 x 5/8 SHCS	Economy
75-3621	40	2	M8 x 16mm SHCS	Economy
75-3623	45	2	M8 x 16mm SHCS	Drop-In

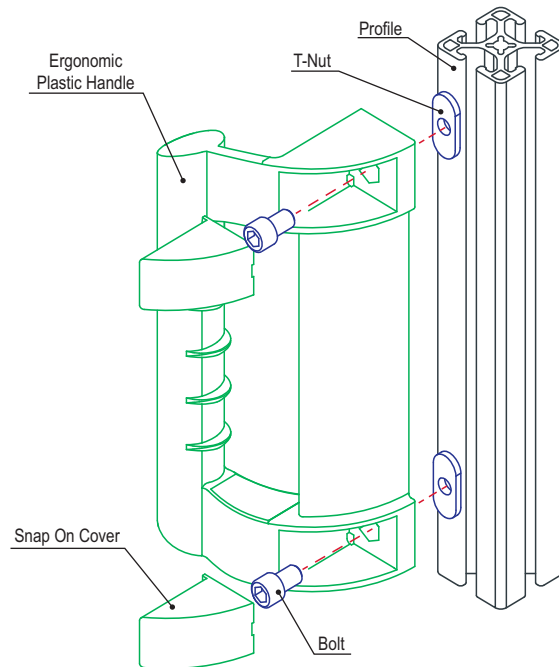

Part Description:

The aluminum door handle has a rigid design that creates a smooth shape and durable finish. It is corrosion-resistant, lending itself to both indoor and outdoor applications. It is available in black or natural mill finish and mounts directly to a T-slot profile.

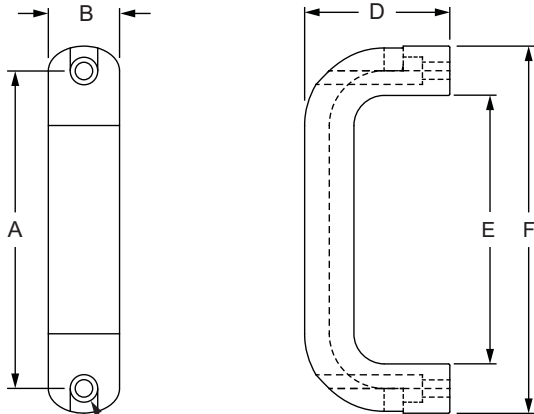

DRILL THRU & COUNTERBORE



Part No.	Series	Material	Finish	Process	Color	A	B	C	D	E	F	Weight
2884	10 15	Aluminum	Textured Powder Coat	Extruded	Black	4.570"	1.020"	1/4	2.090"	3.858"	5.275"	.354 lb
2885	10 15		Tumbled Mill		Silver	4.570"	1.020"	1/4	2.090"	3.858"	5.275"	.343 lb
2886	10 15		Textured Powder Coat		Black	6.460"	1.020"	1/4	2.240"	5.750"	7.165"	.453 lb
2887	10 15		Tumbled Mill		Silver	6.460"	1.020"	1/4	2.240"	5.750"	7.165"	.459 lb
40-2884	25 30 40 45		Textured Powder Coat		Black	116.00mm	26.00mm	M6	53.00mm	98.00mm	134.00mm	.1589 kg
40-2885	25 30 40 45		Tumbled Mill		Silver	116.00mm	26.00mm	M6	53.00mm	98.00mm	134.00mm	.1533 kg
40-2886	25 30 40 45		Textured Powder Coat		Black	164.00mm	26.00mm	M6	57.00mm	146.00mm	182.00mm	.2118 kg
40-2887	25 30 40 45		Tumbled Mill		Silver	164.00mm	26.00mm	M6	57.00mm	146.00mm	182.00mm	.2095 kg

Suggested Hardware (Mount to T-Slot)

Series	Part No.	Qty.	Bolt	Part No.	Qty.	T-Nut
10	3067	2	1/4-20 x .625" SHCS	3382	2	Economy
15	3064	2	1/4-20 x .750" SHCS	3382	2	Economy
25 30	11-6518	2	M6 x 18mm SHCS	25-1961	2	Economy
40	11-6520	2	M6 x 20mm SHCS	40-1961	2	Economy
45	11-6520	2	M6 x 20mm SHCS	13129	2	Drop-In

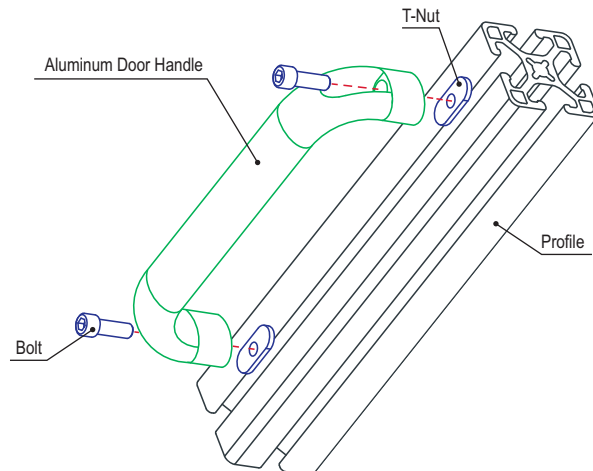

Ready Tube™ Aluminum Handle

Part Description:

The Ready Tube aluminum handle has a durable, black finish and rigid design that creates a smooth shape. It is corrosion-resistant, lending itself to both indoor and outdoor applications. See below for suggested mounting hardware.

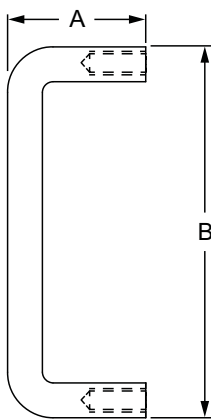

Part No.	Series	Material	Alloy	Finish	A	B	C	D	E	Weight
2888	RT	Aluminum	6061-T6	Black Anodize	1.500"	5.000"	.500"	4.500"	5/16-18	.110 lb
2889	RT				1.500"	6.500"	.500"	6.000"	5/16-18	.137 lb

Suggested Hardware (Mount to Ready Tube Profile)

Part No.	Series	Qty.	Bolt
3753	RT	2	5/16-18 x 2.00" Flanged Hex Head Bolt

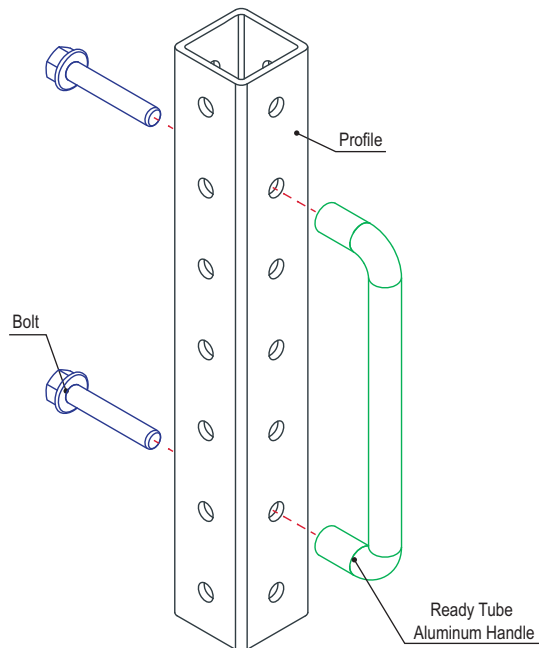

Part Description:

The steel door handle is compact and ideal for smaller areas. It is designed to bolt directly to plastic panels. This handle requires a drill-through service for mounting to plastic panels which can be found on page 892. All of the required mounting hardware is included.

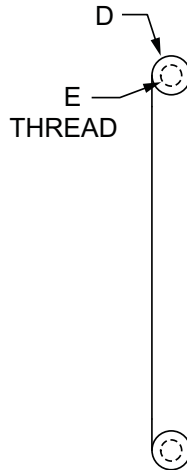
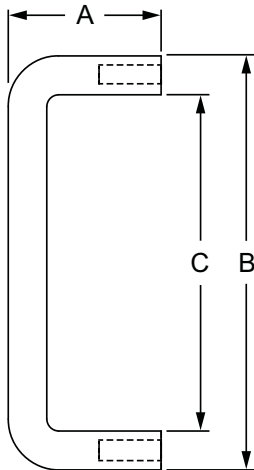

Part No.	Series	Material	Grade	Finish	Process	Color	A	B	C	D	E	Weight
2070	F M	Steel	Carbon	26D Brushed	Formed	Chrome	1.230"	3.300"	2.680"	.310"	8-32 x .500	.104 lb
65-2070	F M						31.20mm	84.00mm	68.30mm	8.00mm	8-32 x .500	.0470 kg

Required Machining Services

Machining Type	Part Machined	Reference Page
Steel Door Handle Plastic Panel Milling	Panel	892

Included Hardware (Mount to 1/4" Panel)

Part No.	Series	Qty.	Bolt
3024	F M	2	8-32 x 1/2" BHSCS

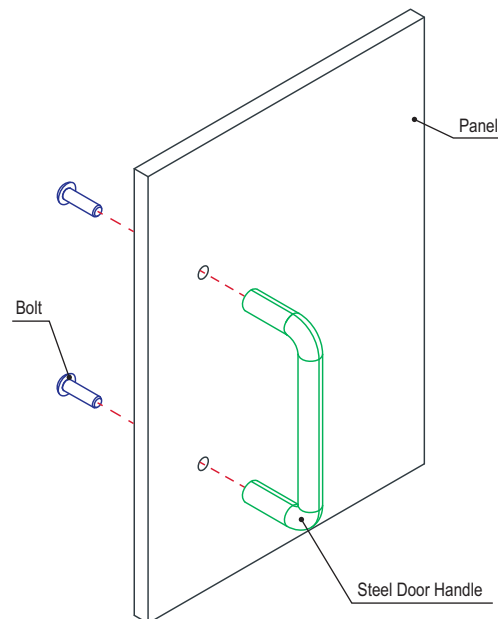

Flush Plastic Panel Handle

Part Description:

The flush plastic panel handle consists of a housing unit and a pull that together create a flush handle that doesn't protrude, convenient for high-traffic areas. It provides an aesthetic appearance and mounts in panels .375" (10mm) or thinner and the mounting hardware is included. A flush handle panel milling service is required which can be found on page 890.



2056, 65-2056



2058, 65-2058

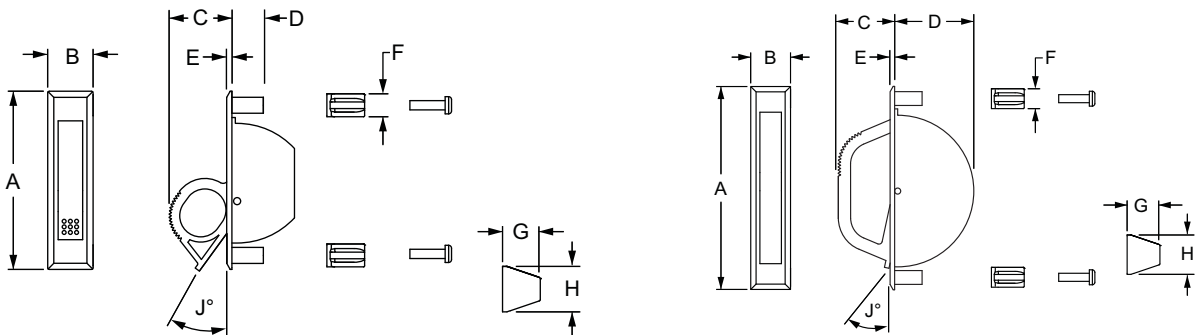

Part No.	Series	Material	Grade	Finish	A	B	C	D	E	F	G	H	J	Weight
2056	F M	Plastic	LNP™ Stat-Kon™	Matte	3.180"	.750"	1.094"	.560"	.094"	.409"	.673"	.811"	30°	.057 lb
2058	F M	Aluminum	—	Black Powder Coat	4.190"	.825"	1.152"	1.625"	.098"	.409"	.673"	.811"	12°	.122 lb
65-2056	F M	Plastic	LNP™ Stat-Kon™	Matte	80.77mm	19.05mm	27.79mm	14.22mm	2.38mm	10.40mm	17.10mm	20.60mm	30°	.0247 kg
65-2058	F M	Aluminum	—	Black Powder Coat	106.40mm	20.95mm	29.26mm	41.27mm	2.49mm	10.40mm	17.10mm	20.60mm	12°	.0562 kg

Required Machining Services

Machining Type	Part Machined	Reference Page
Flush Handle Plastic Panel Milling	Panel	890

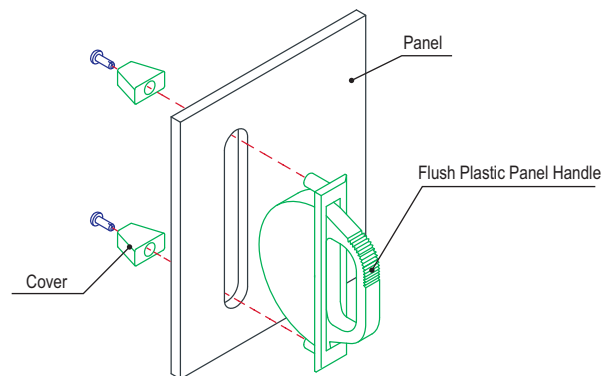



Part Description:

The aluminum handle is made of clear anodized aluminum, making it a strong, lightweight option that is corrosion-resistant, lending itself to both indoor and outdoor applications. It easily mounts to the edge of a .250" (6.35mm) plastic panel and helps add rigidity. The handle is commonly used for sliding doors. It comes in three stock lengths but is available in custom lengths on page 847.

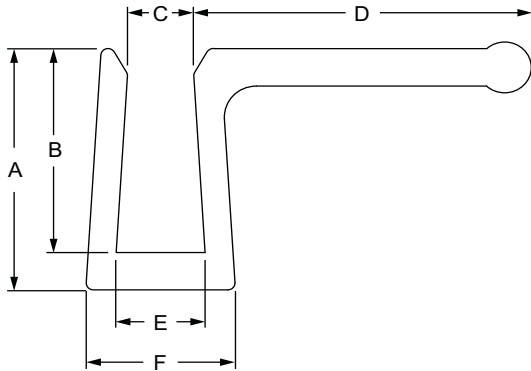

Part No.	Series	A	B	C	D	E	F	Stock Length	Weight
2780	F M	.710"	.600"	.182"	.953"	.245"	.420"	3.000"	.075 lb
2781	F M	.710"	.600"	.182"	.953"	.245"	.420"	6.000"	.150 lb
2782	F M	.710"	.600"	.182"	.953"	.245"	.420"	9.000"	.225 lb
65-2780	F M	18.03mm	15.24mm	4.62mm	24.21mm	6.22mm	10.67mm	76.20mm	.0340 kg
65-2781	F M	18.03mm	15.24mm	4.62mm	24.21mm	6.22mm	10.67mm	152.40mm	.0680 kg
65-2782	F M	18.03mm	15.24mm	4.62mm	24.21mm	6.22mm	10.67mm	228.60mm	.1021 kg

Material Specifications

Material	Alloy*	Finish	Process
Aluminum	6105-T5	Clear Anodize	Extruded

* Or comparable

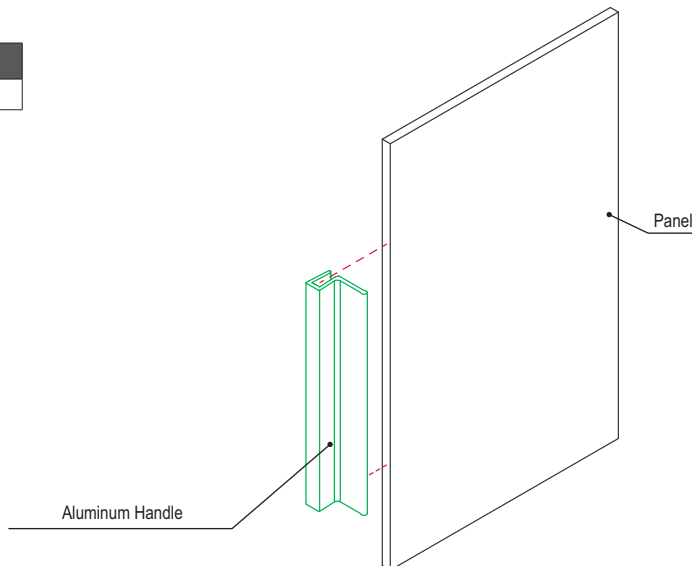

Locking Plastic Panel Grabber™ Handle

80/20[®] Inc.

Part Description:

The locking plastic panel Grabber™ handle is comprised of a black polycarbonate slam action latch, handle, and lock, making it a high-strength option. A striker plate is also included. The slam latch engages the striker plate to help create the closing connection. The locking plastic panel Grabber handle can be opened from either side of the door and mounts to panels between .075" and .275" (2mm-7mm). The mounting hardware is included.

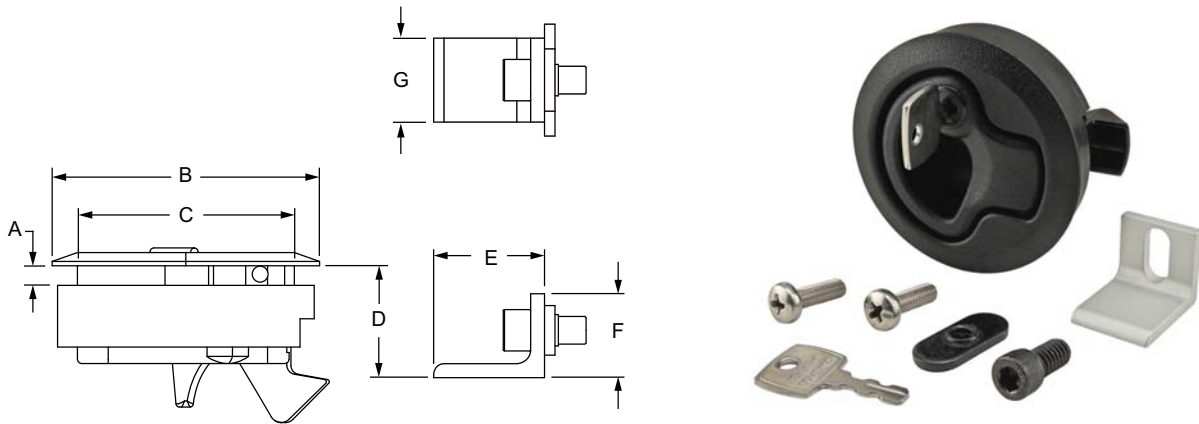

Part No.	Series	Material	Process	Color	A	B	C	D	E	F	G	Weight
2730	10 15 25 30 40 45	PC/PBT Blend	Injection Molded	Black	.075" to .275"	2.413"	1.957"	1.000"	1.000"	.750"	.750"	.180 lb
65-2730	10 15 25 30 40 45				2mm to 7mm	61.30mm	49.70mm	25.40mm	25.40mm	19.05mm	19.05mm	.0806 kg

Required Machining Services

Machining Type	Part Machined	Reference Page
Locking Grabber Handle Panel Milling	Panel	889

Included Hardware (Mount Striker Plate to T-Slot)

Part No.	Series	Qty.	Description
3058	10 25 30	1	1/4-20 x 3/8" SHCS
3062	15 40	1	1/4-20 x 1/2" SHCS
3382	10 15 25 30 40	1	Slide-In Economy T-Nut

Suggested Hardware (Mount Striker Plate to T-Slot)

Part No.	Series	Qty.	Description
11-6514	45	1	M6 x 14mm SHCS
14126	45	1	Slide-In Economy T-Nut Block

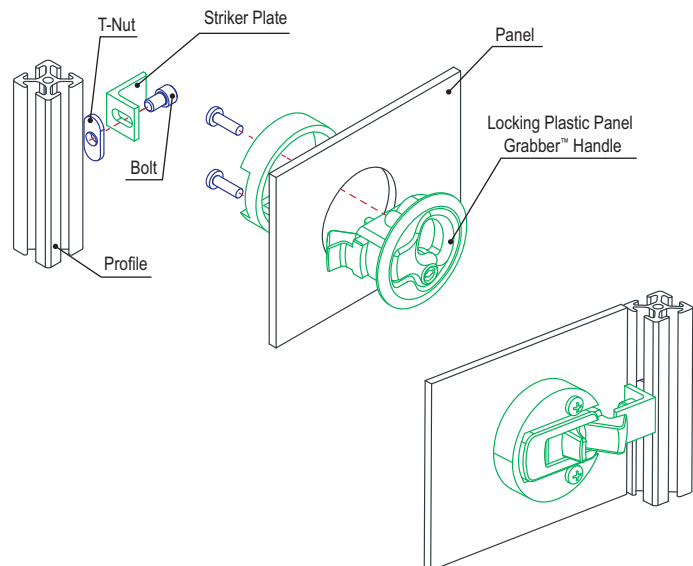

Part Description:

The deluxe door handle with pawl kit has a chrome finish which provides corrosion resistance and an aesthetic appearance. Easily add a deluxe door mating handle to provide handles on both sides of a door. The pawl kit and mounting hardware are included. The deluxe door handle with pawl kit requires a deluxe door handle profile milling service. **Additional Information:** This handle is compatible with the deluxe door mating handle (page 568) as well as other pawl kits which can be found on page 571.

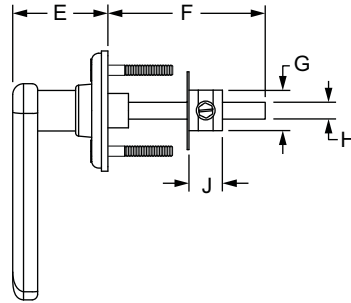
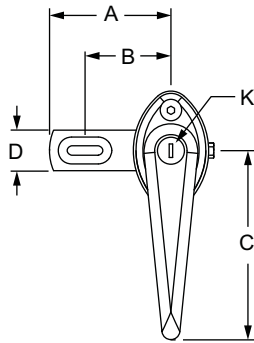

2063, 40-2063

2055, 40-2055



Part No.	Series	A	B	C	D	E	F	G	H	J	K	Weight
2055	15	2.250"	1.590"	3.313"	.750"	1.969"	3.000"	.750"	.313"	.620"	Non-Locking	.301 lb
2063	15	2.250"	1.590"	3.313"	.750"	1.969"	3.000"	.750"	.313"	.620"	Locking	.695 lb
40-2055	30 40	57.15mm	40.38mm	84.15mm	19.05mm	50.00mm	76.20mm	19.05mm	7.95mm	15.75mm	Non-Locking	.3012 kg
40-2063	30 40	57.15mm	40.38mm	84.15mm	19.05mm	50.00mm	76.20mm	19.05mm	7.95mm	15.75mm	Locking	.3065 kg

Material Specifications

Material	Finish
Steel	Chrome

Required Machining Services

Machining Type	Part Machined	Reference Page
Deluxe Door Handle Profile Milling	Profile	866

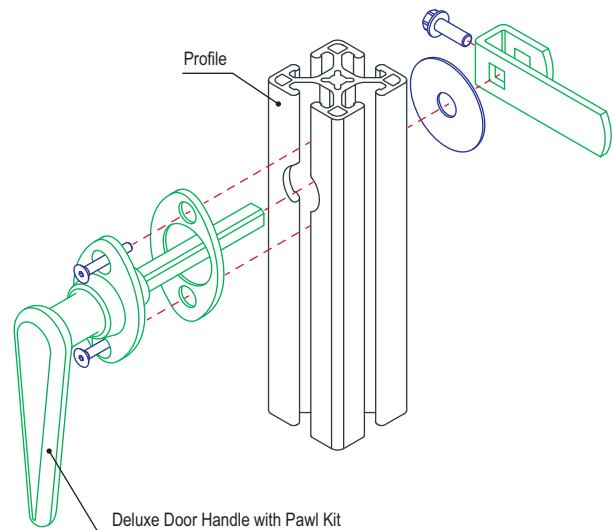

Deluxe Door Mating Handle

Part Description:

The deluxe door mating handle has a chrome finish which provides corrosion resistance and an aesthetic appearance. It easily attaches with a simple set screw to the stem of the deluxe door handle with pawl kit (page 567) to provide handles on both sides of a door. The deluxe door mating handle requires no machining services.

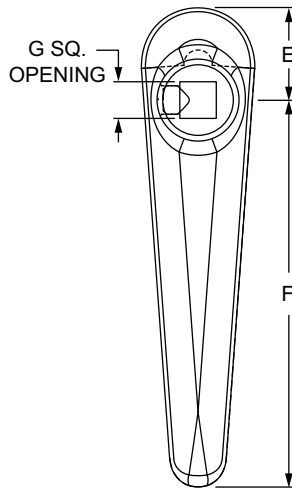
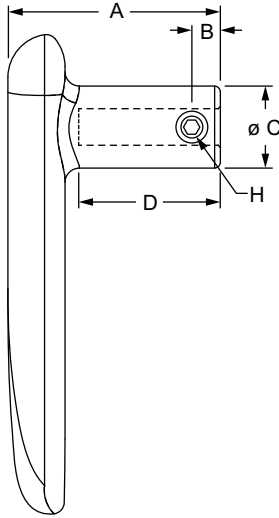

Part No.	Series	Material	Finish	A	B	C	D	E	F	G	H	Weight
2052	15	Steel	Chrome	1.875"	.250"	.719"	1.250"	.813"	3.313"	.320"	1/4-20 x .250	.362 lb
40-2052	30 40			47.63mm	6.35mm	18.26mm	3.18mm	2.07mm	84.15mm	8.13mm	1/4-20 x .250	.1570 kg

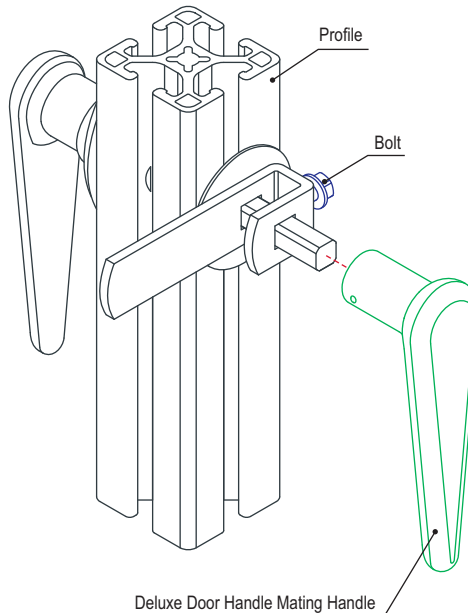



Part Description:

The furniture style handle is available in either chrome-plated or matte black options as well as a "T" or "L" shape. Choices range from locking to unlocking as well as a 90 degree counter-clockwise or clockwise rotation. It requires a furniture style handle profile milling service found on page 867. Use a pawl kit (page 571) with the furniture style handle to create a latching connection. All mounting hardware is included.

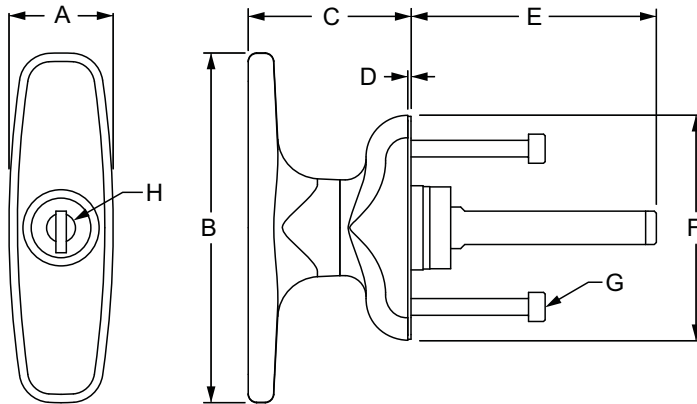

Part No.	Series	Material	Finish	Color	Rotation	A	B	C	D	E	F	G	H	Weight	
2082	10 15	Die Cast Zinc	Chrome	Bright	Counter Clockwise	.984"	3.307"	1.535"	.031"	2.319"	2.126"	M4-0.7	Locking	.552 lb	
2083	10 15					.984"	3.307"	1.535"	.031"	2.319"	2.126"	M4-0.7	Non-Locking	.532 lb	
2952	10 15		Powder Coat	Black		.984"	3.307"	1.535"	.031"	2.319"	2.126"	M4-0.7	Locking	.568 lb	
2953	10 15					.984"	3.307"	1.535"	.031"	2.319"	2.126"	M4-0.7	Non-Locking	.523 lb	
2932	10 15		Chrome	Bright	Clockwise	.984"	3.307"	1.535"	.031"	2.319"	2.126"	M4-0.7	Locking	.686 lb	
2933	10 15					.984"	3.307"	1.535"	.031"	2.319"	2.126"	M4-0.7	Non-Locking	.649 lb	
2922	10 15		Powder Coat	Black		.984"	3.307"	1.535"	.031"	2.319"	2.126"	M4-0.7	Locking	.646 lb	
2923	10 15					.984"	3.307"	1.535"	.031"	2.319"	2.126"	M4-0.7	Non-Locking	.647 lb	
65-2082	25 30 40		Die Cast Zinc	Chrome	Bright	Counter Clockwise	25.00mm	84.00mm	39.00mm	.80mm	57.50mm	54.00mm	M4-0.7	Locking	.2545 kg
65-2083	25 30 40						25.00mm	84.00mm	39.00mm	.80mm	57.50mm	54.00mm	M4-0.7	Non-Locking	.2371 kg
65-2952	25 30 40			Powder Coat	Black		25.00mm	84.00mm	39.00mm	.80mm	57.50mm	54.00mm	M4-0.7	Locking	.3356 kg
65-2953	25 30 40						25.00mm	84.00mm	39.00mm	.80mm	57.50mm	54.00mm	M4-0.7	Non-Locking	.2387 kg
65-2932	25 30 40			Chrome	Bright	Clockwise	25.00mm	84.00mm	39.00mm	.80mm	59.00mm	54.00mm	M4-0.7	Locking	.3113 kg
65-2933	25 30 40						25.00mm	84.00mm	39.00mm	.80mm	59.00mm	54.00mm	M4-0.7	Non-Locking	.2947 kg
65-2922	25 30 40	Powder Coat		Black	25.00mm		84.00mm	39.00mm	.80mm	59.00mm	54.00mm	M4-0.7	Locking	.2934 kg	
65-2923	25 30 40				25.00mm		84.00mm	39.00mm	.80mm	59.00mm	54.00mm	M4-0.7	Non-Locking	.2937 kg	

Required Machining Services

Machining Type	Part Machined	Reference Page
Furniture Style Handle Profile Milling	Profile	867

CONTINUE

Furniture Style Handle (Continued)

80/20[®] Inc.

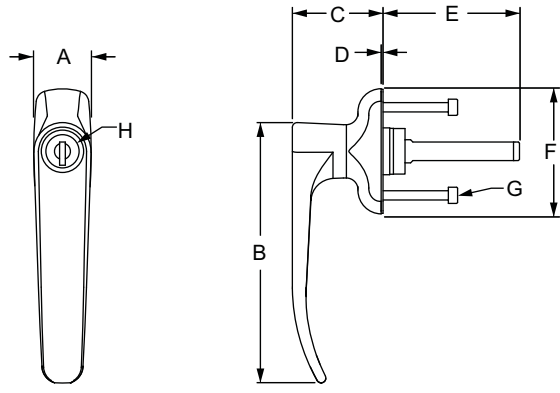

Part No.	Series	Material	Finish	Color	Rotation	A	B	C	D	E	F	G	H	Weight	
2087	10 15	Die Cast Zinc	Chrome	Bright	Counter Clockwise	.984"	4.423"	1.535"	.031"	2.319"	2.126"	M4-0.7	Locking	.580 lb	
2089	10 15					.984"	4.423"	1.535"	.031"	2.319"	2.126"	M4-0.7	Non-Locking	.553 lb	
2957	10 15		Powder Coat	Black		.984"	4.423"	1.535"	.031"	2.319"	2.126"	M4-0.7	Locking	.579 lb	
2959	10 15					.984"	4.423"	1.535"	.031"	2.319"	2.126"	M4-0.7	Non-Locking	.549 lb	
2937	10 15		Chrome	Bright	Clockwise	.984"	4.423"	1.535"	.031"	2.319"	2.126"	M4-0.7	Locking	.701 lb	
2939	10 15					.984"	4.423"	1.535"	.031"	2.319"	2.126"	M4-0.7	Non-Locking	.670 lb	
2927	10 15		Powder Coat	Black		.984"	4.423"	1.535"	.031"	2.319"	2.126"	M4-0.7	Locking	.700 lb	
2929	10 15					.984"	4.423"	1.535"	.031"	2.319"	2.126"	M4-0.7	Non-Locking	.546 lb	
65-2087	25 30 40		Die Cast Zinc	Chrome	Bright	Counter Clockwise	25.00mm	112.34mm	39.00mm	.80mm	59.00mm	54.00mm	M4-0.7	Locking	.2499 kg
65-2089	25 30 40						25.00mm	112.34mm	39.00mm	.80mm	59.00mm	54.00mm	M4-0.7	Non-Locking	.2475 kg
65-2957	25 30 40			Powder Coat	Black		25.00mm	112.34mm	39.00mm	.80mm	59.00mm	54.00mm	M4-0.7	Locking	.2615 kg
65-2959	25 30 40						25.00mm	112.34mm	39.00mm	.80mm	59.00mm	54.00mm	M4-0.7	Non-Locking	.2482 kg
65-2937	25 30 40			Chrome	Bright	Clockwise	25.00mm	112.34mm	39.00mm	.80mm	59.00mm	54.00mm	M4-0.7	Locking	.3180 kg
65-2939	25 30 40						25.00mm	112.34mm	39.00mm	.80mm	59.00mm	54.00mm	M4-0.7	Non-Locking	.3043 kg
65-2927	25 30 40	Powder Coat		Black	25.00mm		112.34mm	39.00mm	.80mm	59.00mm	54.00mm	M4-0.7	Locking	.3177 kg	
65-2929	25 30 40				25.00mm		112.34mm	39.00mm	.80mm	59.00mm	54.00mm	M4-0.7	Non-Locking	.3044 kg	

Required Machining Services

Machining Type	Part Machined	Reference Page
Furniture Style Handle Profile Milling	Profile	867

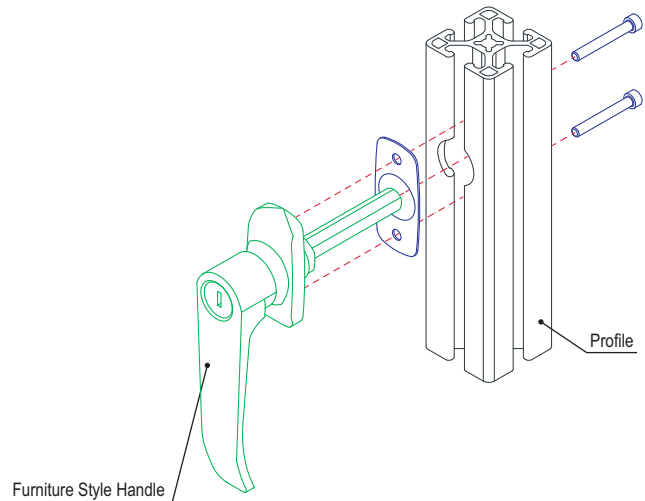

Part Description:

The furniture style handle pawl kit is used to assist in latching a door utilizing a deluxe or furniture style handle which can be found on pages 567-571. There are options available as a transition between the 10 and 15 series or between the 25 and 40 series. All mounting hardware is included.

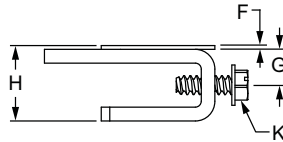
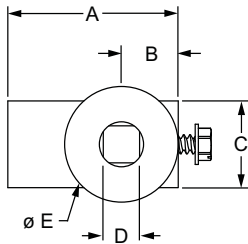

10, 25, 30 Series

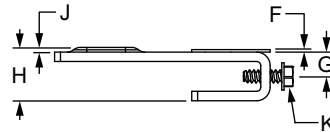
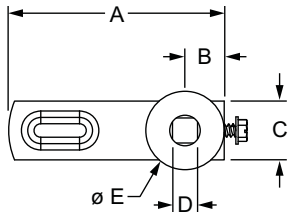

15, 30, 40 Series



Part No.	Series	A	B	C	D	E	F	G	H	J	K	Weight
2761	10	1.250"	.500"	.750"	.320"	1.000"	.032"	.310"	.652"	—	SDS #10 x .500"	.072 lb
2763	10 to 15	1.500"	.500"	.750"	.320"	1.000"	.032"	.310"	.652"	—	SDS #10 x .500"	.088 lb
2765	15	1.750"	.500"	.750"	.320"	1.000"	.032"	.310"	.680"	.060"	SDS #10 x .500"	.086 lb
2760	15	2.750"	.500"	.750"	.320"	1.000"	.032"	.310"	.680"	.060"	SDS #10 x .500"	.118 lb
25-2761	25	31.75mm	12.70mm	19.05mm	8.13mm	25.40mm	.81mm	7.87mm	16.56mm	—	SDS #10 x .500"	.0272 kg
65-2763	25 to 30 25 to 40 30 to 40	38.10mm	12.70mm	19.05mm	8.13mm	25.40mm	.81mm	7.87mm	16.56mm	—	SDS #10 x .500"	.0320 kg
40-2765	40	44.45mm	12.70mm	19.05mm	8.13mm	25.40mm	.81mm	7.87mm	16.56mm	1.52mm	SDS #10 x .500"	.0327 kg
40-2760	40	69.90mm	12.70mm	19.05mm	8.13mm	25.40mm	.81mm	7.87mm	17.27mm	1.52mm	SDS #10 x .500"	.0426 kg

Material Specifications

Material	Grade	Finish	Process
Steel	Low Carbon	Bright Zinc	Stamping / Blending

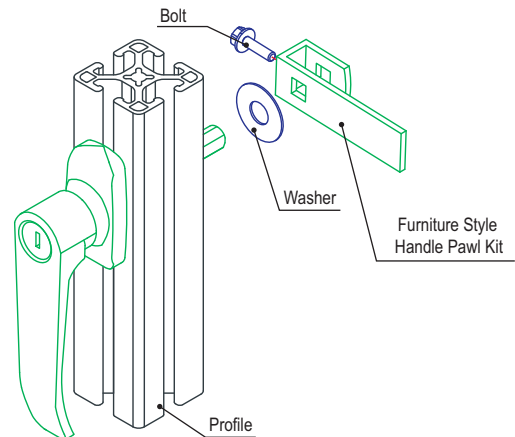

Slam Latch

Part Description:

The slam latch is a die cast aluminum handle that mounts to a T-slot door or frame from the front. It provides a compact handle that takes up only a small amount of space from the surface of the latch to the profile. The slam latch is safe against disassembly in the locked position. There are options available with both locking mechanisms keyed alike, keyed different or without a lock. No machining is required.

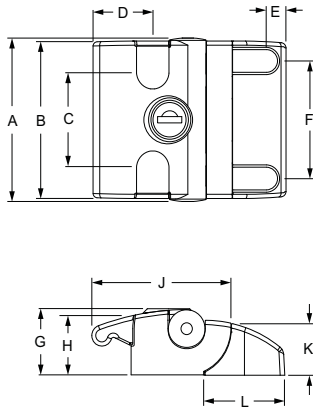

Front View



Back View

Part No.	Series	Lock	A	B	C	D	E	F	G	H	J	K	L	Weight
12145	15 30 40 45	keyed alike	77.80mm	75.00mm	44.40mm	30.00mm	9.90mm	56.00mm	31.60mm	28.30mm	69.00mm	24.50mm	40.20mm	.2404 kg
12146	15 30 40 45	different key	77.80mm	75.00mm	44.40mm	30.00mm	9.90mm	56.00mm	31.60mm	28.30mm	69.00mm	24.50mm	40.20mm	.2418 kg
12147	15 30 40 45	without key	77.80mm	75.00mm	44.40mm	30.00mm	9.90mm	56.00mm	31.60mm	28.30mm	69.00mm	24.50mm	40.20mm	.2002 kg

Material Specifications

Material	Finish	Process	Color
Aluminum	Powder Coat	Die Cast	Black

Suggested Hardware (Mount to T-Slot)

Part No.	Series	Qty.	Description
13-6516	15 30 40 45	4	M6 x 16mm SHCS
13117	30	4	Standard Drop-In T-Nut
13119	15 40	4	Standard Drop-In T-Nut
13129	45	4	Standard Drop-In T-Nut

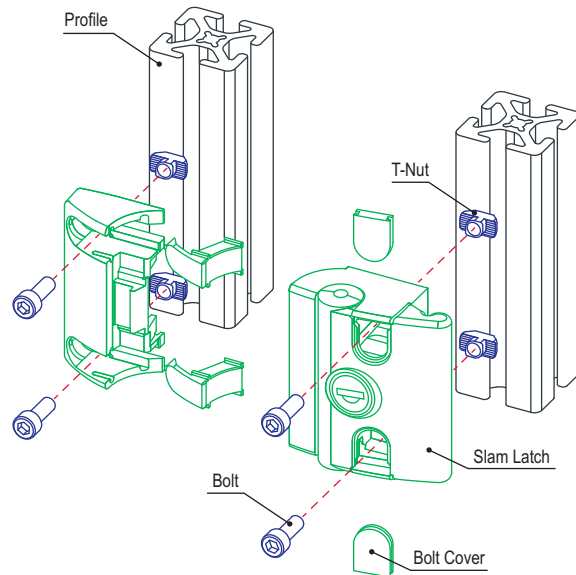

Part Description:

The Velcro[®] latch consists of Velcro[®] material bonded to a clear anodized aluminum body. It includes a fastener hook pad key that twists into a T-slot profile, perfect for instances where profiles are captivated. It is recommended for displays, enclosures, and light-duty doors where easy access is required. All of the mounting hardware is included.

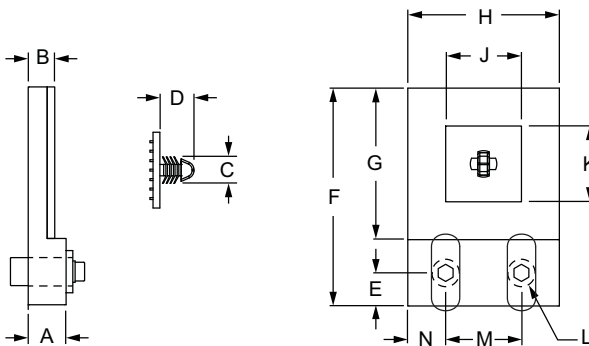

Part No.	Series	A	B	C	D	E	F	G	H	J	K	L	M	N	Weight
2126	15	.500"	.335"	.350"	.448"	.437"	2.875"	2.000"	2.000"	1.000"	1.000"	1/4-20	1.000"	.500"	.243 lb
65-2126	40	12.70mm	8.50mm	8.90mm	11.40mm	11.10mm	73.03mm	50.80mm	50.80mm	25.40mm	25.40mm	M6 x 1.0	25.40mm	12.70mm	.1048 kg

Material Specifications

Housing Material	Alloy*	Pad Material
Aluminum	6105-T5	Velcro [®]

* Or comparable

Included Hardware (Mount Velcro Latch to T-Slot)

Series	Part No.	Qty.	Bolt	Part No.	Qty.	T-Nut
15	3068	2	1/4-20 x 7/8" SHCS	3382	2	Slide-In Economy T-Nut
40	13-6520	2	M6 x 20mm SHCS	3859	2	Slide-In Economy T-Nut

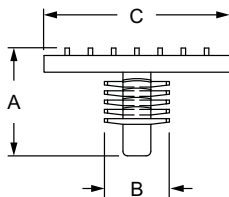
Velcro[®] Fastener

Part No.	Series	A	B	C	Weight
3273	15	.580"	.350"	1.000"	.007 lb
40-3273	40	14.74mm	8.89mm	25.40mm	.0023 kg

Material Specifications

Material	Grade	Process	Color
Plastic	PVC	Injection Mold	Black

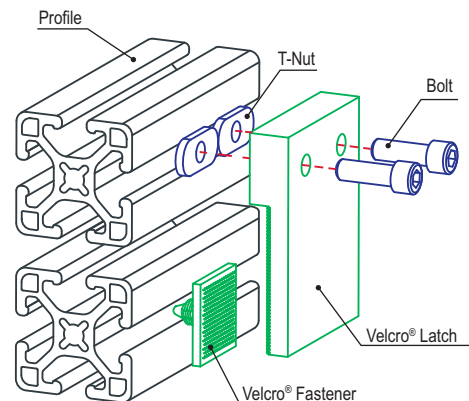

0 Degree Deadbolt Latch

Part Description:

The 0 degree deadbolt latch is made of aluminum, making it strong and corrosion-resistant. The body supports a stainless steel bolt, spring and pin. It has a positive spring-loaded deadbolt which makes it ideal for guarding and enclosure applications. The hardware to mount the latch to a T-slot is included.

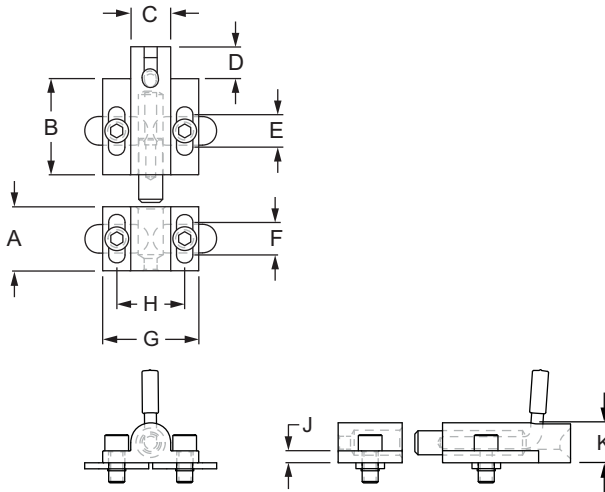

Part No.	Series	Color	A	B	C	D	E	F	G	H	J	K	Weight
2053	10 15	Clear	1.000"	1.500"	.625"	.500"	.507"	.500"	1.500"	1.062"	.187"	.625"	.226 lb
2053-Black	10 15	Black	1.000"	1.500"	.625"	.500"	.507"	.500"	1.500"	1.062"	.187"	.625"	.226 lb
65-2053	25 30 40	Clear	25.40mm	38.10mm	15.88mm	12.70mm	12.88mm	12.70mm	38.10mm	26.97mm	4.75mm	15.88mm	.1007 kg
65-2053-Black	25 30 40	Black	25.40mm	38.10mm	15.88mm	12.70mm	12.88mm	12.70mm	38.10mm	26.97mm	4.75mm	15.88mm	.1007 kg
45-2053	45	Clear	38.00mm	38.10mm	15.88mm	12.70mm	12.88mm	25.40mm	38.10mm	26.97mm	4.75mm	15.88mm	.1212 kg
45-2053-Black	45	Black	38.00mm	38.10mm	15.88mm	12.70mm	12.88mm	25.40mm	38.10mm	26.97mm	4.75mm	15.88mm	.1212 kg

Material Specifications

Material	Alloy*	Finish	Process
Aluminum	6105-T5	Anodize	Milled

* Or comparable

Included Hardware (Mount to T-Slot)

Part No.	Series	Qty.	Description
3062	10 15 25 30 40	4	1/4-20 x 1/2" SHCS
3382		4	1/4-20 Slide-In Economy T-Nut
11-6514	45	4	M6 x 14mm SHCS
13129		4	M6 x 1.0 Drop-in T-Nut

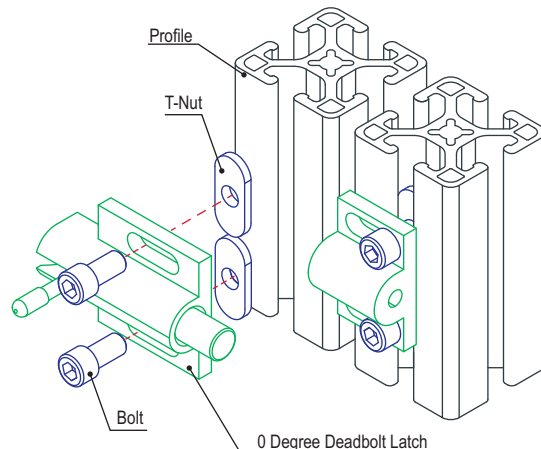

Part Description:

The 90 degree deadbolt latch is made of aluminum, making it strong and corrosion-resistant. The body supports a stainless steel bolt, spring and pin. The pin handle is positioned at a 90 degree angle to prevent snagging. It has a positive spring-loaded deadbolt which makes it ideal for guarding and enclosure applications. The hardware to mount the latch to a T-slot is included.

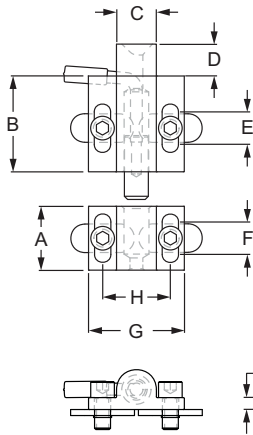

Part No.	Series	Color	A	B	C	D	E	F	G	H	J	K	Weight
2107	10 15	Clear	1.000"	1.500"	.625"	.500"	.507"	.500"	1.500"	1.062"	.187"	.625"	.223 lb
2107-Black	10 15	Black	1.000"	1.500"	.625"	.500"	.507"	.500"	1.500"	1.062"	.187"	.625"	.223 lb
65-2107	25 30 40	Clear	25.40mm	38.10mm	15.88mm	12.70mm	12.88mm	12.70mm	38.10mm	26.97mm	4.75mm	15.88mm	.1004 kg
65-2107-Black	25 30 40	Black	25.40mm	38.10mm	15.88mm	12.70mm	12.88mm	12.70mm	38.10mm	26.97mm	4.75mm	15.88mm	.1004 kg
45-2107	45	Clear	38.00mm	38.10mm	15.88mm	12.70mm	12.88mm	25.40mm	38.10mm	26.97mm	4.75mm	15.88mm	.1209 kg
45-2107-Black	45	Black	38.00mm	38.10mm	15.88mm	12.70mm	12.88mm	25.40mm	38.10mm	26.97mm	4.75mm	15.88mm	.1209 kg

Material Specifications

Material	Alloy*	Finish	Process
Aluminum	6105-T5	Anodize	Milled

* Or comparable

Included Hardware (Mount to T-Slot)

Part No.	Series	Qty.	Description
3062	10 15 25 30 40	4	1/4-20 x 1/2" SHCS
3382		4	1/4-20 Slide-In Economy T-Nut
11-6514	45	4	M6 x 14mm SHCS
13129		4	M6 x 1.0 Drop-in T-Nut

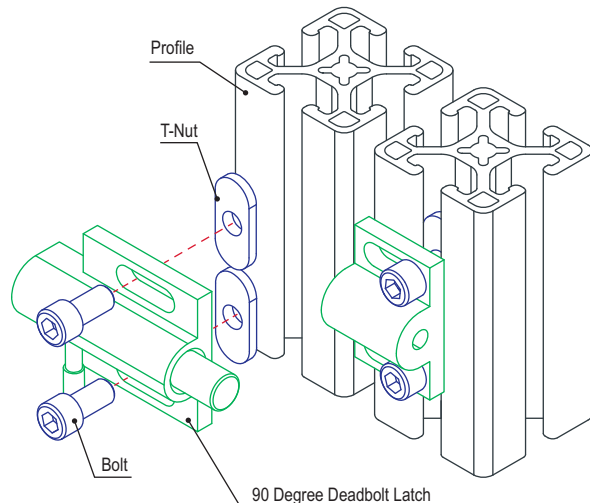

Grabber™ Door Catch

Part Description:

The Grabber™ door catch is made of corrosion-resistant black ABS with three different pull forces available. It is spring-loaded and mounts to a T-slot with a Grabber door catch mounting plate (page 577-578) on the inside of an enclosure to create a push to close/pull to open latch. The required hardware to mount the Grabber door catch to the plate is included. It requires a Grabber door catch clearance machining service which includes the tap.

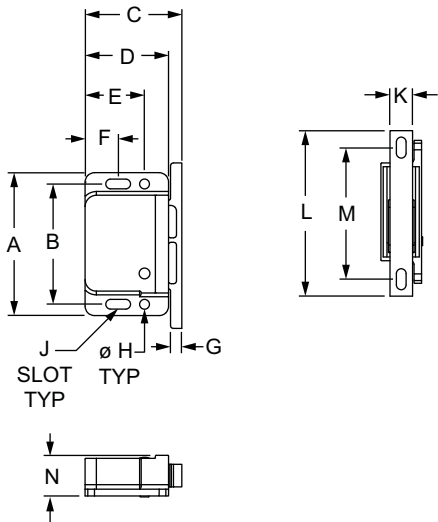

Part No.	Series	A	B	C	D	E	F	G	H	J	K	L	M	N	Pull Force	Weight
2069	10 15	1.900"	1.600"	1.285"	1.110"	.790"	.440"	.150"	.130"	.130 x .330	.300"	2.200"	1.750"	.530"	3.00 lb	.033 lb
2088	10 15	1.900"	1.600"	1.285"	1.110"	.790"	.440"	.150"	.130"	.130 x .330	.300"	2.200"	1.750"	.530"	5.00 lb	.035 lb
2125	10 15	1.900"	1.600"	1.285"	1.110"	.790"	.440"	.150"	.130"	.130 x .330	.300"	2.200"	1.750"	.530"	10.00 lb	.034 lb
65-2069	25 40	48.26mm	40.60mm	32.65mm	28.20mm	20.07mm	11.20mm	3.81mm	3.30mm	3.30mm x 8.40mm	7.62mm	55.88mm	44.45mm	13.70mm	1.40 kg	.0162 kg
65-2088	25 40	48.26mm	40.60mm	32.65mm	28.20mm	20.07mm	11.20mm	3.81mm	3.30mm	3.30mm x 8.40mm	7.62mm	55.88mm	44.45mm	13.70mm	2.30 kg	.0161 kg
65-2125	25 40	48.26mm	40.60mm	32.65mm	28.20mm	20.07mm	11.20mm	3.81mm	3.30mm	3.30mm x 8.40mm	7.62mm	55.88mm	44.45mm	13.70mm	4.60 kg	.0152 kg

Material Specifications

Material	Process	Color
PC / ABS	Injection Molded	Black

Required Machining Services

Machining Type	Part Machined	Reference Page
Grabber Door Catch Panel Milling	Panel	889

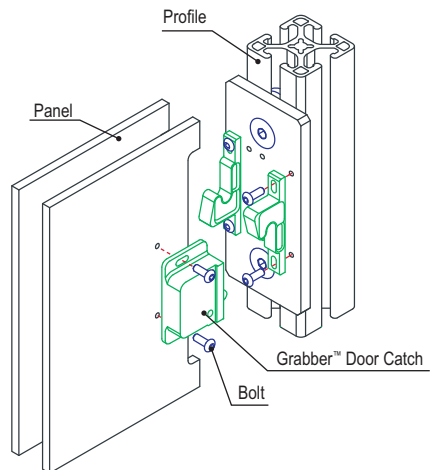

PANELS & DOORS

Part Description:

The Grabber™ door catch mounting plate is made of .250" anodized aluminum and is used to mount the Grabber door catch (page 576) to a T-slot or plastic panel.

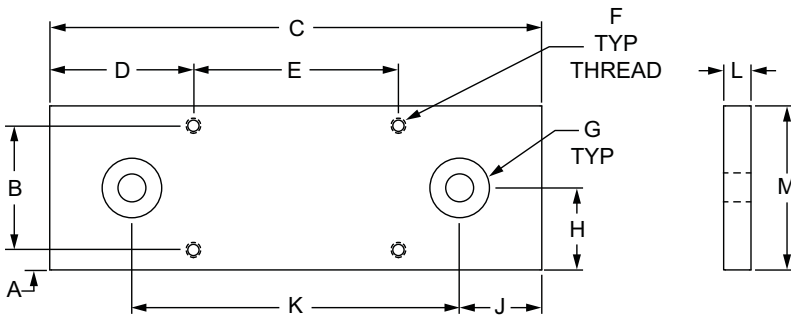

Part No.	Series	Color	A	B	C	D	E	F	G	H	J	K	L	M	Weight
2122	10	Clear	.182"	1.136"	4.500"	1.313"	1.875"	#6-32	5/16-18	.750"	.750"	3.000"	.250"	1.500"	.155 lb
2122-Black	10	Black	.182"	1.136"	4.500"	1.313"	1.875"	#6-32	5/16-18	.750"	.750"	3.000"	.250"	1.500"	.155 lb
25-2122	25	Clear	4.62mm	28.85mm	114.30mm	33.35mm	47.63mm	#6-32	M8 x 1.25	19.05mm	18.67mm	76.20mm	6.35mm	38.10mm	.0706 kg
25-2122-Black	25	Black	4.62mm	28.85mm	114.30mm	33.35mm	47.63mm	#6-32	M8 x 1.25	19.05mm	18.67mm	76.20mm	6.35mm	38.10mm	.0706 kg

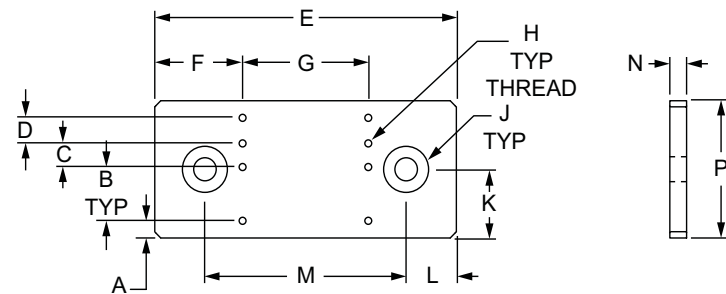

Part No.	Series	Color	A	B	C	D	E	F	G	H	J	K	L	M	N	P	Weight
2121	15	Clear	.250"	.780"	.345"	.375"	4.500"	1.312"	1.875"	#6-32	5/16-18	1.000"	.750"	3.000"	.250"	2.000"	.202 lb
2121-Black	15	Black	.250"	.780"	.345"	.375"	4.500"	1.312"	1.875"	#6-32	5/16-18	1.000"	.750"	3.000"	.250"	2.000"	.202 lb
40-2121	40	Clear	6.35mm	19.81mm	8.76mm	9.53mm	114.30mm	33.32mm	47.63mm	#6-32	M8 x 1.25	25.40mm	19.05mm	76.20mm	6.35mm	50.80mm	.0924 kg
40-2121-Black	40	Black	6.35mm	19.81mm	8.76mm	9.53mm	114.30mm	33.32mm	47.63mm	#6-32	M8 x 1.25	25.40mm	19.05mm	76.20mm	6.35mm	50.80mm	.0924 kg

Grabber™ Door Catch Mounting Plate (Continued)

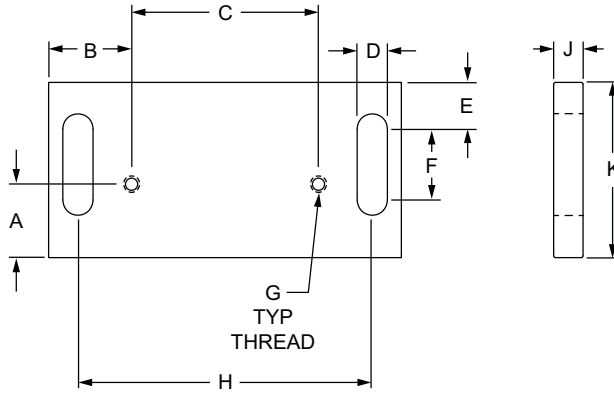

Part No.	Series	Color	A	B	C	D	E	F	G	H	J	K	Weight
2123	10 15	Clear	.625"	.705"	1.590"	.257"	.395"	.605"	#6-32	2.500"	.250"	1.490"	.097 lb
2123-Black	10 15	Black	.625"	.705"	1.590"	.257"	.395"	.605"	#6-32	2.500"	.250"	1.490"	.097 lb
65-2123	25 40	Clear	15.88mm	17.90mm	40.38mm	6.53mm	10.03mm	15.37mm	#6-32	63.50mm	6.35mm	37.85mm	.0440 kg
65-2123-Black	25 40	Black	15.88mm	17.90mm	40.38mm	6.53mm	10.03mm	15.37mm	#6-32	63.50mm	6.35mm	37.85mm	.0440 kg

Material Specifications

Material	Alloy*	Finish	Process
Aluminum	6105-T5	Anodize	Milled

* Or comparable

Suggested Hardware (Mount to T-Slot)

Part No.	Bolt Assy.	Series	Qty.	Bolt	T-Nut
2122	3414	10	2	1/4-20 x 1/2" FHSCS	Economy
2123	3321	10	2	1/4-20 x 1/2" FBHSCS	Economy
2123	3371	15	2	1/4-20 x 3/4" BHSCS	Economy
2121	3412	15	2	5/16-18 x 5/8" FHSCS	Economy
25-2122	75-3507	25	2	M6 x 12mm FHSCS	Economy
65-2123	75-3405	25	2	M6 x 12mm BHSCS	Economy
65-2123	75-3406	40	2	M6 x 16mm BHSCS	Economy
40-2121	75-3508	40	2	M8 x 16mm FHSCS	Economy

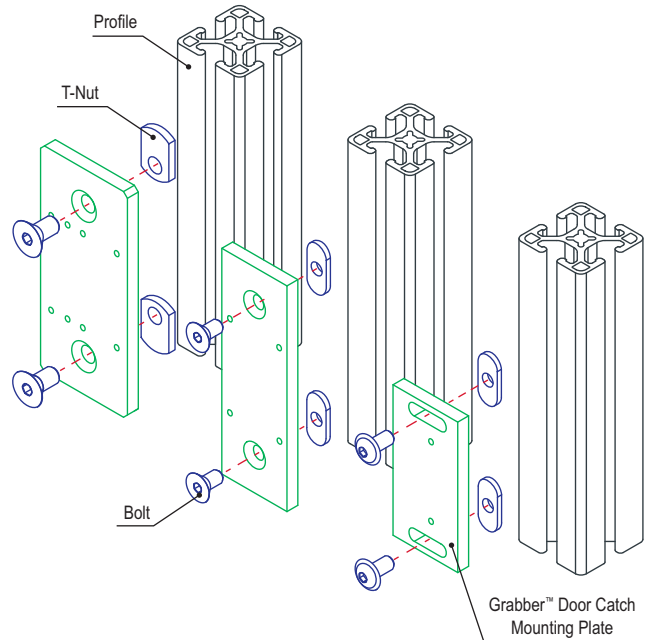

Part Description:

The magnetic door catch is lightweight and ideal for latching plastic panels in place. It has an estimated pull force of 12 pounds (5.443 kilograms). All of the mounting hardware is included. The magnetic door catch requires a panel tap service to mount the striker plate to the plastic panel (page 897).

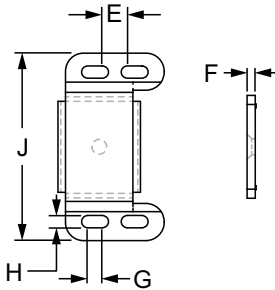
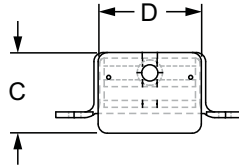
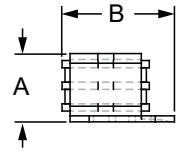

Part No.	Series	Color	A	B	C	D	E	F	G	H	J	Weight
2090	10 15	Bright	.710"	1.172"	.880"	1.130"	.275"	.090"	.163"	.135"	2.060"	.141 lb
65-2090	25 30 40		18.03mm	29.78mm	22.35mm	28.70mm	6.99mm	2.29mm	4.13mm	3.43mm	52.32mm	.0680 kg
9315	QF		.710"	1.172"	.880"	1.130"	.275"	.090"	.163"	.135"	2.060"	.123 lb

Material Specifications

Material	Finish	Process
Steel	Zinc	Formed

Required Machining Services

Machining Type	Part Machined	Reference Page
Tap	Panel	897

Included Hardware (Mount to T-Slot)

Part No.	Series	Qty.	Description
3005	10 15 25 30 40	2	8-32 x 3/8" BHSCS
3275	10 15 25 30 40	2	Slide-In Economy T-Nut
9325	QF	2	1/4-14 x 3/4" SDS

Included Hardware (Mount Striker Plate to Panel)

Part No.	Series	Qty.	Description
209002	10 15 25 30 40 QF	1	6-32 x 3/8" FHSCS

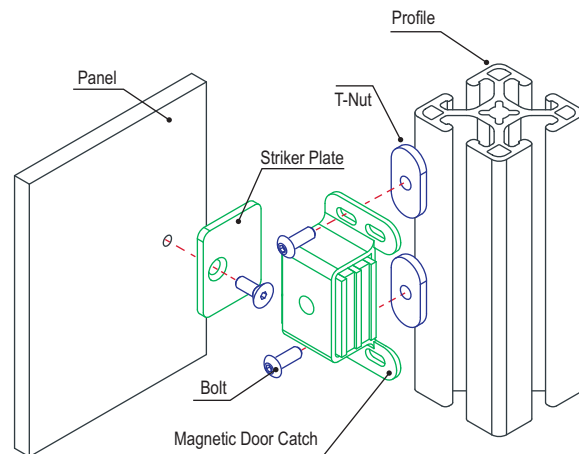

Magnetic Door Catch Bracket

Part Description:

The magnetic door catch bracket is used to attach the magnet to a T-slotted profile door. All mounting hardware is included.

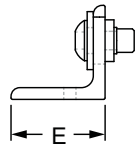
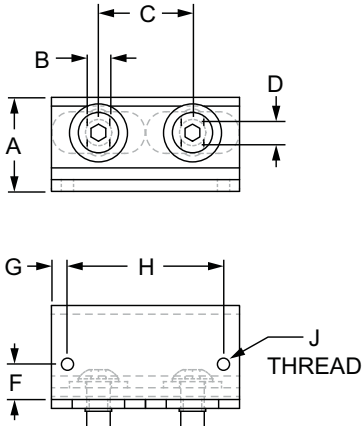

Part No.	Series	Color	A	B	C	D	E	F	G	H	J	Weight
2745	10 15	Clear	1.000"	.250"	1.000"	.250"	1.000"	.375"	.170"	1.660"	8-32	.087 lb
2745-Black	10 15	Black	1.000"	.250"	1.000"	.250"	1.000"	.375"	.170"	1.660"	8-32	.087 lb
65-2745	25 40	Clear	25.40mm	6.35mm	25.40mm	6.35mm	25.40mm	9.53mm	4.32mm	42.16mm	8-32	.0372 kg
65-2745-Black	25 40	Black	25.40mm	6.35mm	25.40mm	6.35mm	25.40mm	9.53mm	4.32mm	42.16mm	8-32	.0372 kg

Material Specifications

Material	Alloy*	Finish	Process
Aluminum	6105-T5	Anodize	Milled

* Or comparable

Included Hardware (Mount to T-Slot)

Series	Qty.	Part No.	Qty.	Part No.	Qty.	Part No.
10 15	2	3061	2	3382	2	3258
25 40	2	13-6312	2	3859	2	13-6041

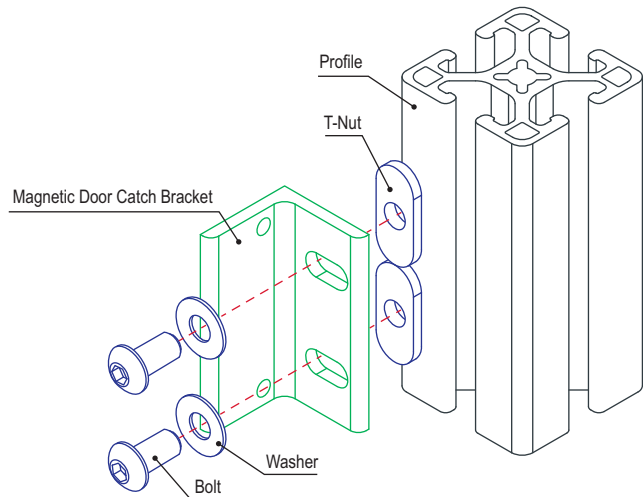

Part Description:

The nylon magnetic door catch consists of a latch and a striker button. The latch is made of molded black fiberglass-reinforced nylon and is a quick-catching method ideal for lightweight plastic panel doors. A panel tap is required to mount the striker button (page 897).

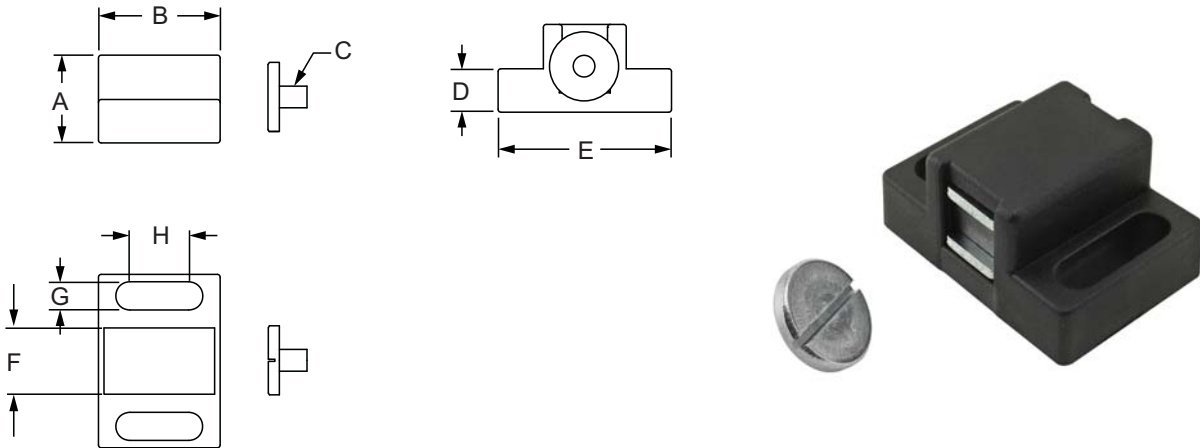

Part No.	Series	Color	A	B	C	D	E	F	G	H	Weight
4486	10 15	Black	.795"	1.102"	M5 x 0.8	.393"	1.570"	.600"	.255"	.532"	.078 lb
65-4486	25 40		20.19mm	28.00mm	M5 x 0.8	10.00mm	39.88mm	15.24mm	6.48mm	13.51mm	.0354 kg

Material Specifications

Material	Finish	Process
Nylon	Black	Injection Molded

Required Machining Services

Machining Type	Part Machined	Reference Page
Tap	Panel	897

Suggested Hardware (Mount to T-Slot)

Part No.	Series	Qty.	Bolt	T-Nut
3493	10	2	1/4-20 x 5/8" SHCS	Economy
3304	15	2	1/4-20 x 3/4" SHCS	Economy
75-3522	25	2	M6 x 16mm SHCS	Economy
75-3596	40	2	M6 x 18mm SHCS	Drop-In

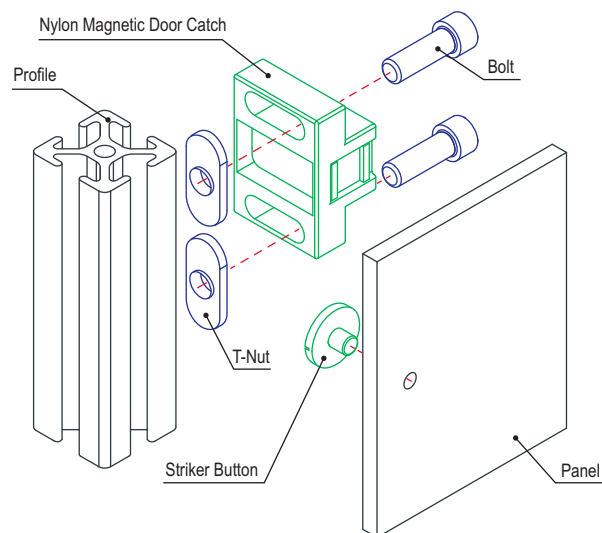

Single Ball Catch

Part Description:

The single ball catch is comprised of a molded black fiberglass-reinforced nylon latch and a zinc-plated steel ball. It is a quick-latching method ideal for lightweight plastic panel doors. The steel ball can latch onto either the top or the front of the catch. The single ball catch requires a panel tap service to mount the steel ball to a plastic panel (page 897).

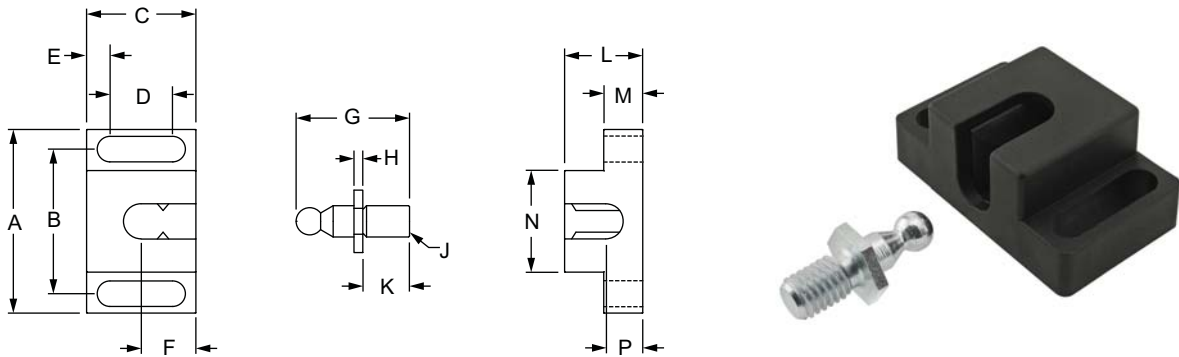

Part No.	Series	A	B	C	D	E	F	G	H	J	K	L	M	N	P	Weight
4487	10 15	1.890"	1.457"	1.102"	.630"	.236"	.512"	1.110"	.087"	M8 x 1.25	.472"	.787"	.394"	.984"	.335"	.062 lb
65-4487	25 30 40	48.00mm	37.00mm	28.00mm	16.00mm	6.00mm	13.00mm	28.20mm	2.20mm	M8 x 1.25	12.00mm	20.00mm	10.00mm	25.00mm	8.50mm	.0281 kg

Material Specifications

Material	Process	Color
Nylon PA	Injection Molded	Black

Required Machining Services

Machining Type	Part Machined	Reference Page
Drill Thru Tap	Panel	897

Suggested Hardware (Mount to T-Slot)

Part No.	Series	Qty.	Bolt	T-Nut
3493	10	2	1/4-20 x 5/8" SHCS	Economy
3304	15	2	1/4-20 x 3/4" SHCS	Economy
75-3522	25 30	2	M6 x 16mm SHCS	Economy
75-3596	40	2	M6 x 18mm SHCS	Drop-In

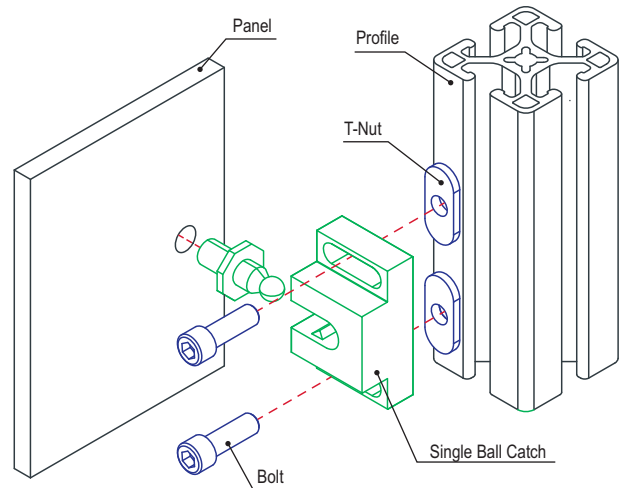

Part Description:

The double ball catch is comprised of a latch and a striker made of molded black fiberglass-reinforced nylon. The catch includes two stainless steel spring-loaded balls that are corrosion-resistant. The suggested hardware to attach the catch to a T-slot can be found below.

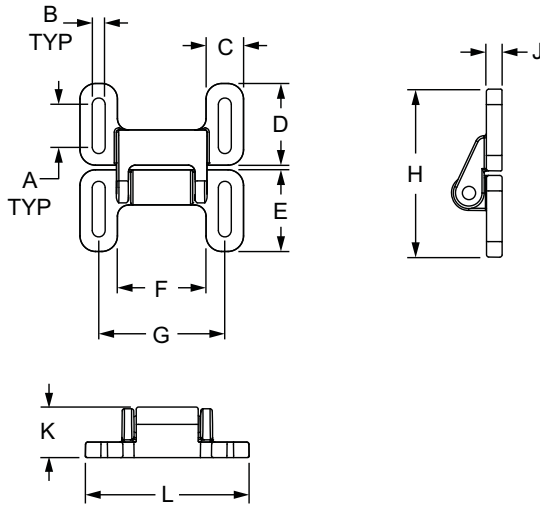

Part No.	Series	A	B	C	D	E	F	G	H	J	K	L	Weight
12019	10 15 25 30 40 45	19.50mm	5.44mm	17.00mm	37.00mm	37.00mm	40.00mm	57.00mm	76.00mm	7.00mm	22.87mm	73.90mm	.0410 kg

Material Specifications

Material	Process	Color
Nylon	Injection Molded	Black

Suggested Hardware (Mount to T-Slot)

Series	Qty.	Part No.	Qty.	Part No.	Qty.	Part No.
10 25	4	11-5314	4	25-1951	4	11-6040
15	4	13-5516	4	13116	4	13-6040
30	4	13-5512	4	13115	4	13-6040
40	4	13-5520	4	13116	4	13-6040
45	4	13-5520	4	13127	4	13-6040

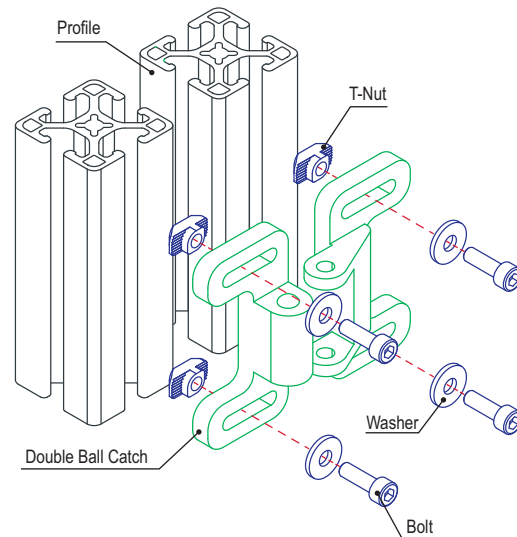

Tension Ball Latch

Part Description:

The tension ball latch is comprised of a latch, striker plate and mounting plate. The latch tension adjusts with two spring-loaded screws allowing the striker to enter from either the front or the side. This is a strong and durable method that creates a secure connection and is ideal for latching. The hardware to attach the hinge to a T-slot is included and no machining services are required.

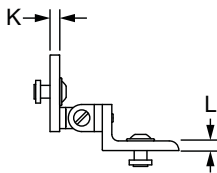
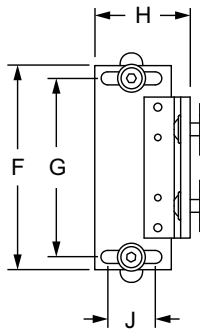
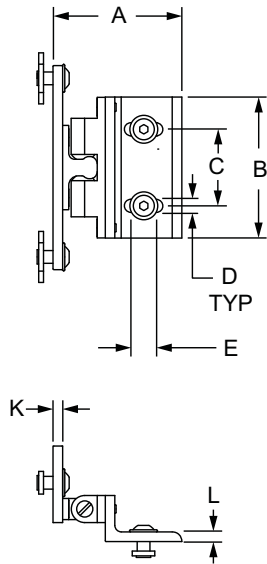

Part No.	Series	Color	A	B	C	D	E	F	G	H	J	K	L	Weight
2134	15 30 40 45	Clear	2.523"	2.764"	1.500"	.257"	.500"	4.000"	3.500"	1.871"	.938"	.188"	.188"	.439 lb
2134-Black	15 30 40 45	Black	2.523"	2.764"	1.500"	.257"	.500"	4.000"	3.500"	1.871"	.938"	.188"	.188"	.439 lb

Material Specifications

Material	Alloy*	Finish
Aluminum	6105-T5	Anodize

* Or comparable

Included Hardware (Mount to T-Slot)

Part No.	Series	Qty.	Description
3342	15 30 40 45	4	1/4-20 x 1/2" FBHSCS
3382	15 30 40 45	4	Slide-In Economy T-Nut

Suggested Hardware (Mount to T-Slot)

Part No.	Series	Qty.	Bolt
13-6316	45	4	M6 x 16mm BHSCS
13129	45	4	Standard Drop-In T-Nut

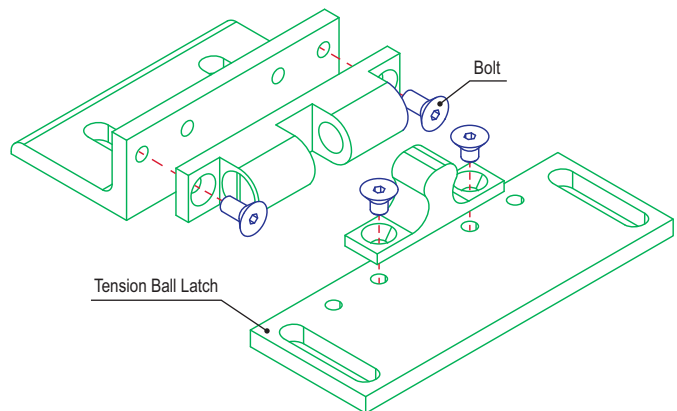

Part Description:

The sliding door lock has an attractive chrome finish and is used with a sliding door track (page 512-513) to lock .250" (6.35mm) sliding panels. This economical security lock is keyed, making it ideal for storage or display cases. Multiple quantities of the sliding door lock are keyed alike.

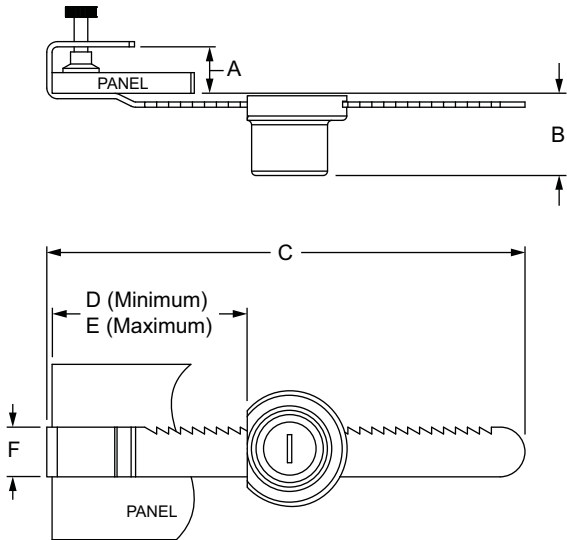

Part No.	Series	Material	Finish	A	B	C	D	E	F	Weight
2057	F M	Steel	Chrome	.500"	.938"	5.500"	1.250"	4.500"	.567"	.210 lb
65-2057	F M			12.70mm	23.81mm	139.70mm	31.75mm	114.30mm	14.40mm	.1006 kg

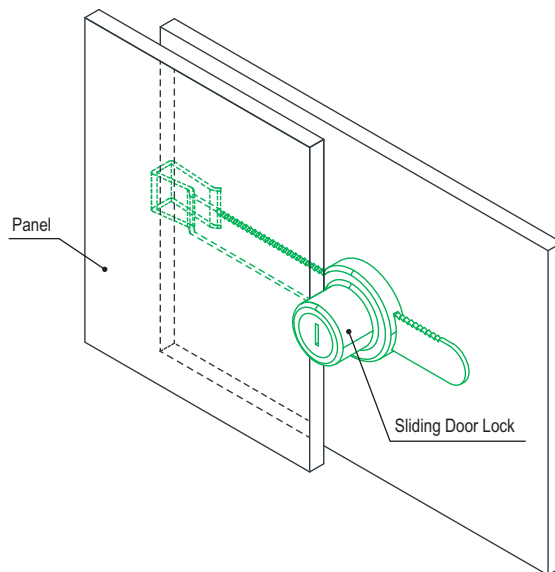

Panel Stiffener

Part Description:

The panel stiffener is used to add rigidity to large .250" (6.35mm) thick panels. It easily connects to a panel using only a soft-face mallet. Panel stiffener comes in a stock length of 72.5 inches (1841.5mm) but is available in custom lengths on page 847.

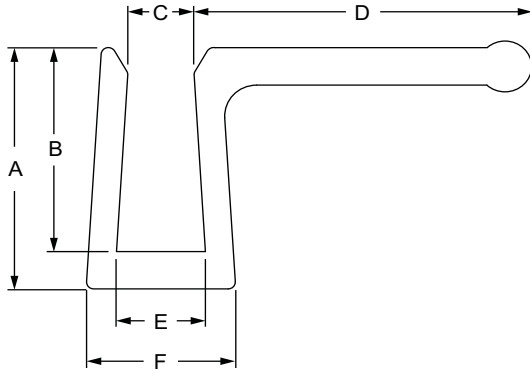

Part No.	Series	A	B	C	D	E	F	Stock Length	Weight
2424	F M	.710"	.600"	.182"	—	.245"	.417"	72.500"	1.015 lb
2429	F M	.710"	.600"	.182"	.953"	.245"	.420"	72.500"	1.813 lb
65-2424	F M	18.03mm	15.24mm	4.62mm	—	6.22mm	10.59mm	1841.50mm	.4604 kg
65-2429	F M	18.03mm	15.24mm	4.62mm	24.21mm	6.22mm	10.67mm	1841.50mm	.8224 kg

Material Specifications

Material	Alloy*	Finish	Process
Aluminum	6105-T5	Clear Anodize	Extruded

* Or comparable

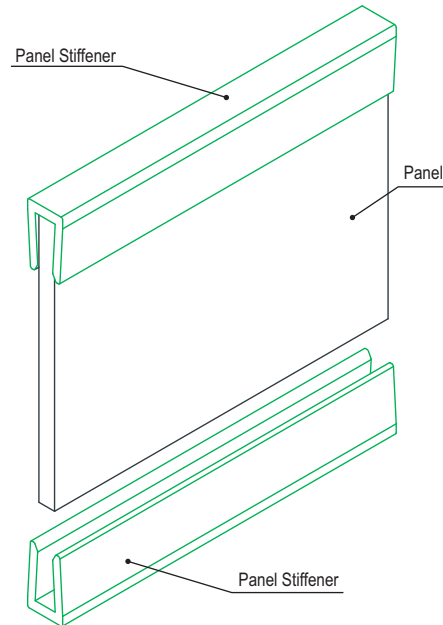

Part Description:

Standard panel gasket is made of high density black polypropylene and recesses in a T-slot from the top or end to secure plastic panels. It is recommended for panels that are .240" (6.096mm) thick. **Tip:** Use an edge radius machining service (page 878) for easy insertion in the T-slot.

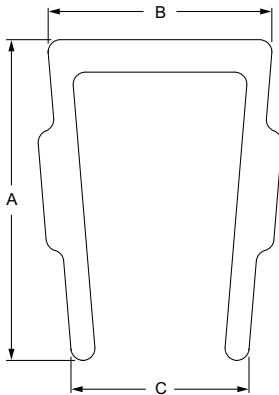

Part No.	Series	Material	Process	Color	A	B	C	Length	Weight
2120	15	Polypropylene	Extruded	Black	.469"	.327"	.260"	72.500"	.118 lb
40-2120	40				11.90mm	8.31mm	6.61mm	1841.50mm	.0547 kg

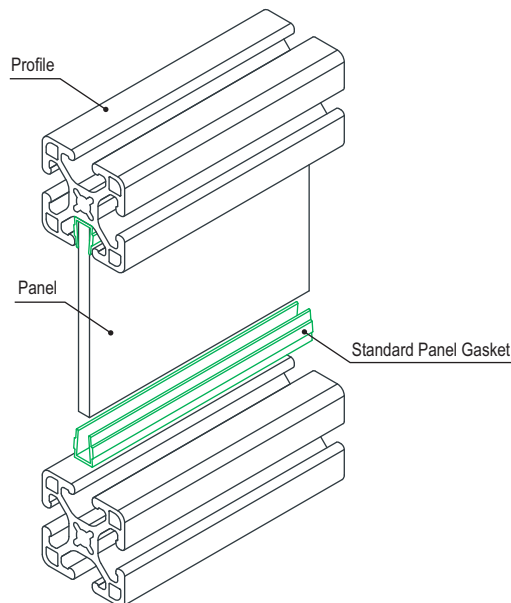

Economy Panel Gasket

Part Description:

Economy panel gasket is available in either a black thermoplastic elastomer or gray silicone rubber. It recesses in a T-slot to secure plastic panels, plates, and mesh and is easily inserted after a panel has been placed in the T-slot. The economy panel gasket can be ordered by the foot (meter) or in 150 foot (45.7 meter) rolls. **Tip:** Cut ends at a 45 degree angle for corner connections to avoid overlap or crashing.



2115



2178

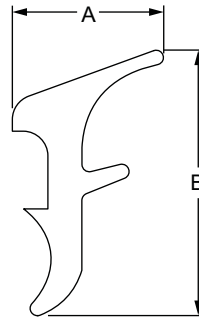

2177



2116

Part No.	Series	Material	Finish	Process	Color	A	B	Length	Weight
2116	10	Thermoplastic Elastomer	Gloss	Extruded	Black	.208"	.362"	per foot	.011 lb / ft
2118	10	Thermoplastic Elastomer			Black	.208"	.362"	per 150 foot roll	2.377 lb
2177	10	Silicone Rubber			Gray	.208"	.362"	per foot	.016 lb / ft
2115	15	Thermoplastic Elastomer			Black	.311"	.547"	per foot	.022 lb / ft
2117	15	Thermoplastic Elastomer			Black	.311"	.547"	per 150 foot roll	4.027 lb
2178	15	Silicone Rubber			Gray	.311"	.547"	per foot	.028 lb / ft
14157	20	Thermoplastic Elastomer			Black	5.80mm	7.60mm	per meter	.0148 kg / m
25-2116	25	Thermoplastic Elastomer			Black	5.28mm	9.19mm	per meter	.0148 kg / m
25-2118	25	Thermoplastic Elastomer			Black	5.28mm	9.19mm	per 45.7 meter roll	1.0218 kg
25-2177	25	Silicone Rubber			Gray	5.28mm	9.19mm	per meter	.0247 kg / m
40-2115	30 40	Thermoplastic Elastomer			Black	7.90mm	13.89mm	per meter	.0370 kg / m
40-2117	30 40	Thermoplastic Elastomer			Black	7.90mm	13.89mm	per 45.7 meter roll	1.8985 kg
40-2178	40	Silicone Rubber			Gray	7.90mm	13.89mm	per meter	.0018 kg / m
14160	45	Thermoplastic Elastomer			Black	11.13mm	19.40mm	per meter	.0018 kg / m

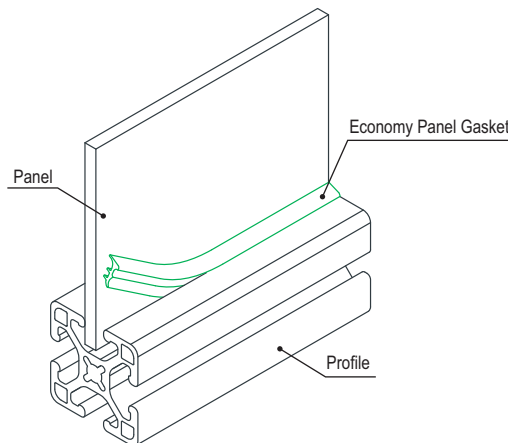

Part Description:

The rubber door seal is made of black EPDM rubber which provides flexibility, making it a longer-lasting option. It has a keyed pad that presses into a T-slot. The rubber door seal is available for 15 and 40 series and is sold by the foot or in 100 foot rolls. **Important:** A minimum door gap of .250" (6.35mm) is required when using the rubber door seal.

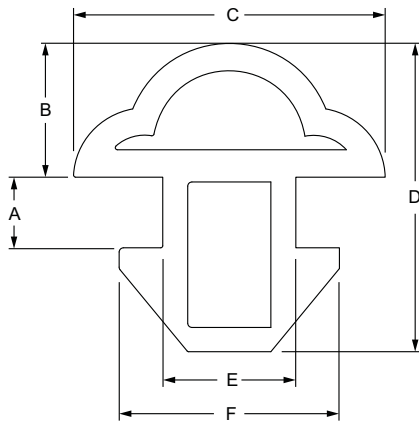

Part No.	Series	Color	A	B	C	D	E	F	Length	Weight
2829	15 40	Black	.170"	.322"	.750"	.742"	.320"	.530"	per foot	.090 lb / ft
2834	15 40		.170"	.322"	.750"	.742"	.320"	.530"	per 100 foot roll	8.393 lb / 100 ft

Material Specifications

Material	Finish	Process
Thermoplastic Elastomer	Matte	Extruded

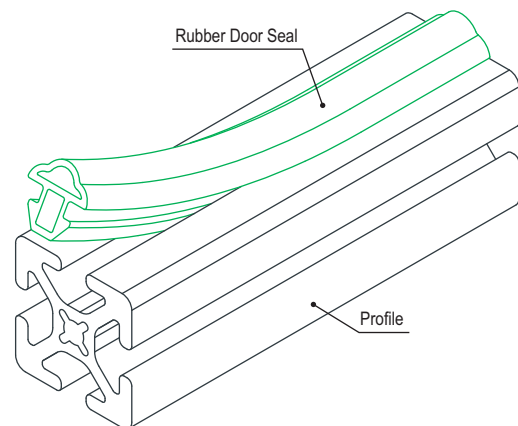

Wire Edge Cover

Part Description:

The wire edge cover is made of black flexible PVC with internal clips; it crimps on the edge of wire mesh or expanded metal panels and is ideal for creating a clean and safe guarding or enclosure access point. Wire edge cover is sold by the foot or meter.

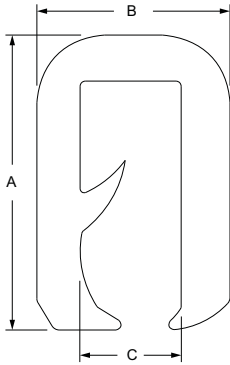

Part No.	Series	Material	Finish	Process	Color	A	B	C	Length	Max Length	Weight
2465	F M	PVC / Aluminum	Pebble Finish	Co-Extrusion	Black	.545"	.357"	.187"	per foot	250 foot roll	.194 lb / ft
65-2465	F M					13.84mm	9.07mm	4.75mm	per meter	76.2 meter roll	.1050 kg / m

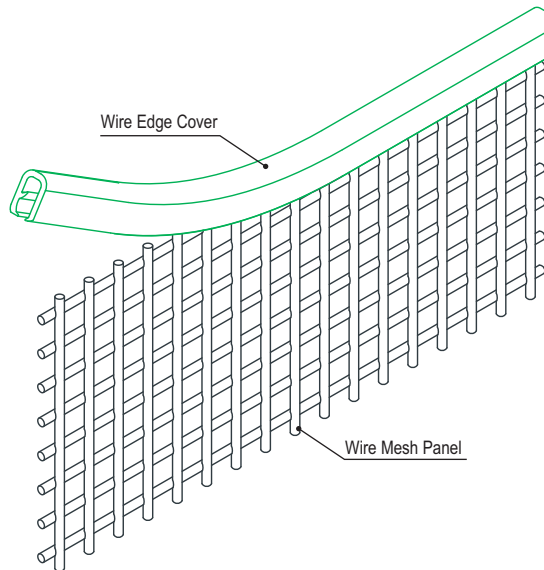

Part Description:

The aluminum door stop is a strong and long-lasting option that prevents a door from swinging too far into the frame. It is corrosion-resistant, lending it to both indoor and outdoor use.

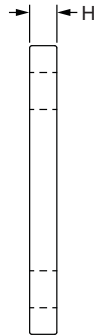
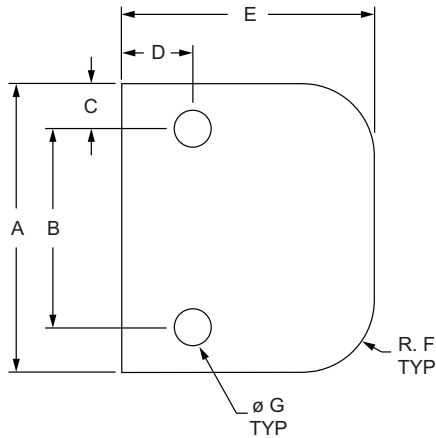

Part No.	Series	Material	Alloy*	Finish	A	B	C	D	E	F	G	H	Weight
4483	10 15 25 30 40 45	Aluminum	6105-T5	Clear Anodize	2.000"	1.375"	.313"	.492"	1.750"	.500"	.257"	.188"	.066 lb
4483-Black	10 15 25 30 40 45			Black Anodize	2.000"	1.375"	.313"	.492"	1.750"	.500"	.257"	.188"	.066 lb

* Or comparable

Suggested Hardware (Mount to T-Slot)

Series	Part No.	Qty.	Bolt	T-Nut	Qty.	T-Nut
10	3061	2	1/4-20 x 1/2" BHSCS	3376	2	Roll-in
15	3063	2	1/4-20 x 5/8" BHSCS	3933	2	Drop-in
25	11-6310	2	M6 x 10mm BHSCS	25-1966	2	Roll-in
30	11-6312	2	M6 x 12mm BHSCS	13117	2	Drop-in
40	11-6316	2	M6 x 16mm BHSCS	13119	2	Drop-in
45	11-6316	2	M6 x 16mm BHSCS	13129	2	Drop-in

Nylon Door Stop

Part Description:

The nylon door stop is a cost-effective option that prevents a door from swinging too far into the frame. It includes rubber bumpers for a soft close.

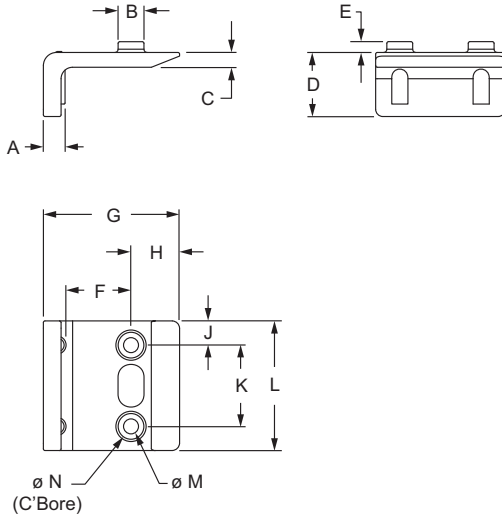

Part No.	Series	Material	Color	A	B	C	D	E	F	G	H	J	K	L	M	N	Weight
2021	15 40	Nylon	Black	.260"	.310"	.177"	.768"	.130"	.780"	1.634"	.582"	.289"	.976"	1.555"	.177"	.307" x .118" DEEP	.280 lb

Suggested Hardware (Mount to T-Slot)

Series	Part No.	Qty.	Bolt	Part No.	Qty.	T-Nut
15 40	11-4312	2	M4 x 12mm BHSCS	25-1941	2	Slide-in

Pictorial Table Of Contents

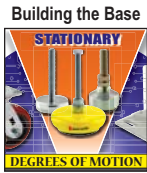

Page 595



Page 595



Page 596



Page 596



Page 596

Casters and Leveling Feet

Threaded Stem Swivel Caster



Page 597

Furniture Style Caster



Page 598

Flanged Mount Swivel Caster



Page 599

Flanged Mount Rigid Caster



Page 601

Triangular Top Plate Caster



Page 602

Deluxe Flange Mount Swivel Caster



Page 603

Deluxe Flange Mount Rigid Caster



Page 604

Heavy-Duty Flange Mount Swivel Caster



Page 605

Heavy-Duty Flange Mount Rigid Caster



Page 606

Leveling Caster



Page 607

Adjustable Position Floor Lock



Page 608

Standard Floor Glide



Page 609

Economy Floor Glide



Page 610

Large Base Glide



Page 611

Mighty Mount[®]



Page 612

Economy Anti-Vibration Mount



Page 613

Deluxe Leveling Foot



Page 614

Economy Leveling Foot



Page 615

Swivel Foot Base



Page 616

Swivel Foot Base with Mount Holes



Page 617

Swivel Foot Threaded Stem



Page 618

Swivel Foot Extended Base



Page 620

Swivel Foot Trapezoid Base



Page 621

Trapezoid Base Anchor



Page 622

Wedge Floor Anchor



Page 623

Die-Cast Floor Bracket



Page 624

Adjustable Die-Cast Floor Bracket



Page 625

Steel Floor Bracket



Page 626

CONTINUE



Pictorial Table Of Contents

Aluminum
Floor Bracket



Page 627

Threaded
End Bracket



Page 628

Base Plates

Flange Mount
Caster Base Plate



Page 629

Heavy-Duty
Flange Mount
Caster Base Plate



Page 631

Leveling Caster
Base Plate



Page 632

Position Floor
Lock Base Plate



Page 634

3 Hole - Center
Tap Base Plate



Page 636

5 Hole - Center
Tap Base Plate



Page 638

4 Hole - Offset
Tap Base Plate



Page 640

2 Hole - Leveling
Anchoring
Base Plate



Page 642

4 Hole - Leveling
Anchoring
Base Plate



Page 643

6 Hole - Leveling
Anchoring
Base Plate



Page 645

Floor Mount
Base Plate



Page 646

Economy Floor
Mount Base Plate



Page 648

Slotted Economy
Floor Mount
Base Plate



Page 650

3 Hole - Die-Cast
Center Tap
Base Plate



Page 651

5 Hole - Die-Cast
Center Tap
Base Plate



Page 652

Building the Base

Once you've got your design narrowed down it's time to start thinking about your base. There are several varieties available, from casters to furniture glides, leveling feet, or anchors. Some add movement and provide a swivel or a pivot, while others lock or reduce vibration. There are also feet that do just what their name implies; level or anchor your project. You can also choose from options that provide combinations of these features.



You'll want to consider how often your application will need to be in motion or relocated. For example, work carts are constantly moving and turning while furniture only occasionally needs repositioned. In contrast, a guard or larger machine may never need moved or only very infrequently. There may also be a need to immobilize equipment. Determining the frequency of movement will help you decide if you need a caster, a leveling foot, a glide or perhaps a floor lock or anchor.

Consider the Capacity

After you've decided on the type of foot that works best for your project, you'll want to begin narrowing down your product choices. One of the main factors will be the required load capacity. Keep in mind that the ratings are per foot; if you're using multiple bases the weight will be distributed and provide a higher overall capacity.



Find Your Footing

Casters, glides, bases, leveling feet and anchors are a great way to customize your application and design it to fit your specific space and purpose. There are several added features to choose from.

Caster Options

When using a caster, there are options available that swivel or remain rigid. Some of the casters also include locking mechanisms. The leveling caster is a great combination foot that incorporates both mobility and leveling features with one component.

The threaded stem swivel caster is one of many casters with or without brakes that 80/20 offers.



Leveling Feet, Glide Options

Glides, leveling feet and bases come in a wide range of varieties. There are choices suitable for different surfaces such as concrete or carpet or that provide leveling and shock-resistance. Select from options with a pad that help reduce and absorb vibration. There are also heavier and lighter-duty bases to pick from.

Options include feet that are both resistant to vibration and pivot up to 20 degrees to accommodate uneven floors.



Add Stability with a Base Plate

Many feet mount to the profile using a base plate. There are several plates available; this allows you to mount your foot anywhere along the profile T-slot or end, reducing limitations on where you can position the foot.

There are also alternatives that let you attach a foot directly to the profile end without the need for a base plate. You'll want to keep in mind that the profile will require an end tap.



Part Description:

The threaded stem swivel caster is a foot that adds mobility to an application and can mount directly to a T-slot profile end, or to the profile side using a base plate. There are options available with a side or front mount brake kit as well as varieties without a brake. The swivel enables easy movement and pivot turns. It is oil resistant, making it ideal for use in industrial settings such as mobile carts and workstations. For end tap services refer to page 853. For base plate options see pages 629-652.

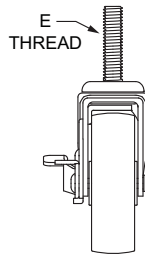
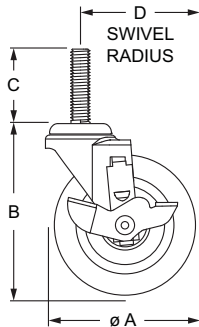

Part No.	Series	Material	Finish	Color	Brake	A	B	C	D	E	Load Height	Load Capacity	Weight
2298	F	Steel / Soft Rubber	Zinc	Black	No	1.625"	2.313"	1.500"	1.625"	3/8-16	2.313"	70.00 lb	.265 lb
2299	F	Steel / Soft Rubber			Yes	2.000"	2.531"	1.500"	1.812"	3/8-16	2.531"	70.00 lb	.444 lb
2300	F	Steel / Soft Rubber			Yes	3.000"	3.531"	1.500"	2.375"	3/8-16	3.531"	100.00 lb	.585 lb
2310	F	Steel / Soft Rubber			Yes	4.000"	4.531"	1.500"	3.250"	7/16-14	4.531"	125.00 lb	1.263 lb
2305	F	Steel / Hard Rubber			Yes	4.000"	4.531"	1.500"	3.250"	7/16-14	4.531"	140.00 lb	1.596 lb
2306	F	Steel / Soft Rubber			Yes	5.000"	5.531"	1.500"	3.875"	7/16-14	5.531"	125.00 lb	1.641 lb
2307	F	Steel / Hard Rubber			Yes	5.000"	5.531"	1.500"	3.875"	7/16-14	5.531"	145.00 lb	1.641 lb
65-2340	M	Steel / Soft Rubber			No	35.00mm	50.00mm	80.00mm	41.27mm	M10 x 1.5	50.00mm	34.02 kg	.1481 kg
65-2341	M	Steel / Soft Rubber			Yes	50.00mm	64.30mm	94.30mm	50.80mm	M10 x 1.5	64.30mm	34.02 kg	.2021 kg
65-2342	M	Steel / Soft Rubber			Yes	75.00mm	89.70mm	119.70mm	73.03mm	M10 x 1.5	89.70mm	45.36 kg	.3142 kg
65-2343	M	Steel / Soft Rubber	Yes	100.00mm	115.10mm	145.10mm	82.55mm	M10 x 1.5	115.10mm	66.00 kg	.5480 kg		
65-2344	M	Steel / Soft Rubber	Yes	125.00mm	140.50mm	170.50mm	98.43mm	M10 x 1.5	140.50mm	68.00 kg	.7171 kg		
65-2345	M	Steel / Hard Rubber	Yes	100.00mm	115.10mm	145.10mm	82.55mm	M12 x 1.75	115.10mm	79.00 kg	.5715 kg		
65-2346	M	Steel / Hard Rubber	Yes	125.00mm	140.50mm	170.50mm	98.43mm	M12 x 1.75	140.50mm	79.00 kg	.7343 kg		

Required Machining Services

Machining Type	Machined	Reference Page
End Tap	Mounting Profile	853

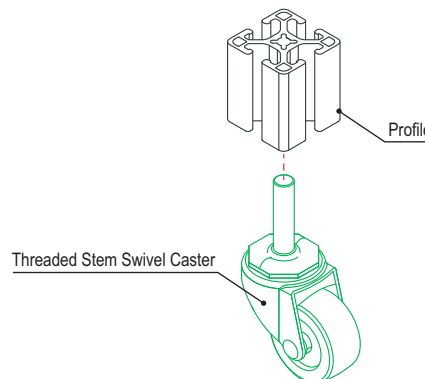

Furniture Style Caster

Part Description:

The furniture style caster is a foot that adds mobility to an application and can mount directly to a T-slot profile end, or to the profile side or end using a base plate. There are options available with or without brakes. The Quick Frame caster connects to a tube profile using a connector (see pages 433-434). The furniture style caster works well in office and home solutions such as desks and furniture. For base plate options see pages 629-652 and for end tap services refer to page 853.

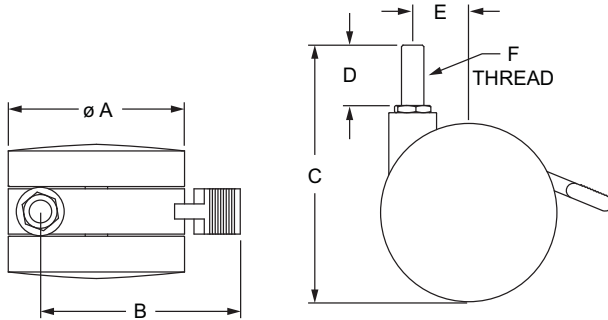

Without Brake
2291, 2293, 2295



With Brake
2292, 2294, 2296



Quick Frame
9361

Part No.	Series	Material	Color	Brake	A	B	C	D	E	F	Load Height	Load Capacity	Weight
2291	F	Steel / Nylon	Black	No	2.850"	—	4.250"	1.000"	.944"	3/8-16	3.250"	165.00 lb	.417 lb
2292	F			Yes	2.850"	3.660"	4.250"	1.000"	.944"	3/8-16	3.250"	165.00 lb	.468 lb
2293	F			No	3.930"	—	5.375"	1.000"	1.370"	3/8-16	4.375"	175.00 lb	.726 lb
2294	F			Yes	3.930"	4.880"	5.375"	1.000"	1.370"	3/8-16	4.375"	175.00 lb	.722 lb
2295	F			No	4.920"	—	6.437"	1.000"	1.370"	1/2-13	5.438"	180.00 lb	1.091 lb
2296	F			Yes	4.920"	5.750"	6.437"	1.000"	1.370"	1/2-13	5.438"	180.00 lb	1.172 lb
9361	QF			No	2.394"	—	3.725"	.984"	.827"	—	2.741"	130.00 lb	.246 lb

Required Machining Services

Machining Type	Machined	Reference Page
End Tap	Mounting Profile	853

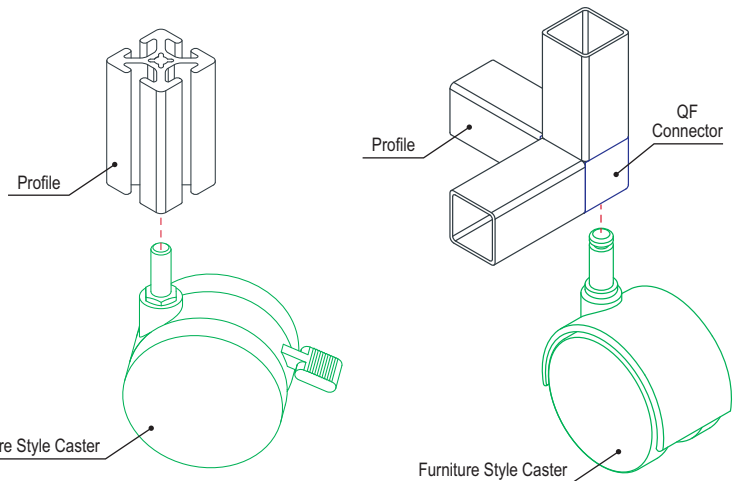



Part Description:

The flange mount swivel caster is a foot that adds mobility to an application and commonly mounts to the T-slot profile end or side using a base plate. The swivel enables easy movement and pivot turns. There are options available with a side or front mount brake kit; the side brake locks only the wheel while the front brake locks both the wheel and the swivel motion. This is ideal for use in industrial settings such as mobile carts and material handling solutions. For base plate options see pages 629-652.

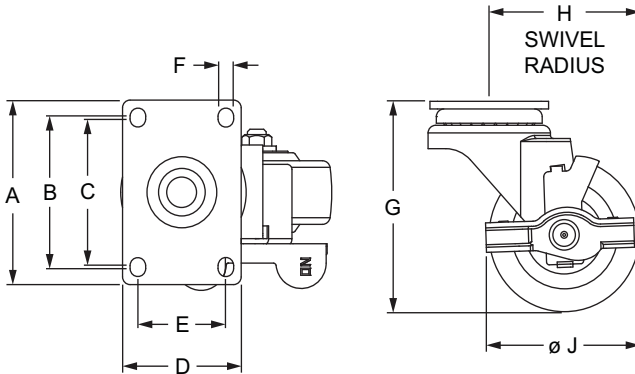

Part No.	Series	Brake	A	B	C	D	E	F	G	H	J	Load Height	Load Capacity	Weight
2317	F	Side	3.625"	3.000"	2.875"	2.375"	1.750"	.328"	4.125"	3.000"	3.000"	4.125"	150.00 lb	1.725 lb
2318	F		3.625"	3.000"	2.875"	2.375"	1.750"	.328"	4.125"	3.000"	3.000"	4.125"	200.00 lb	1.740 lb.
65-2317	M		92.08mm	76.20mm	73.03mm	60.33mm	44.45mm	8.33mm	104.78mm	76.20mm	92.08mm	104.78mm	68.04 kg	.7668 kg
65-2318	M		92.08mm	76.20mm	73.03mm	60.33mm	44.45mm	8.33mm	104.78mm	76.20mm	92.08mm	104.78mm	90.72 kg	.7790 kg

Material Specifications

Part No.	Material	Finish	Color
2317	Steel / Soft Rubber	Zinc	Black
2318	Steel / Hard Rubber		
65-2317	Steel / Soft Rubber		
65-2318	Steel / Hard Rubber		

Suggested Hardware (Mount to Base Plate)

Part No.	Series	Qty.	Bolt
3110	F	4	5/16-18 x 5/8" SHCS
13-8520	M	4	M8 x 20mm SHCS

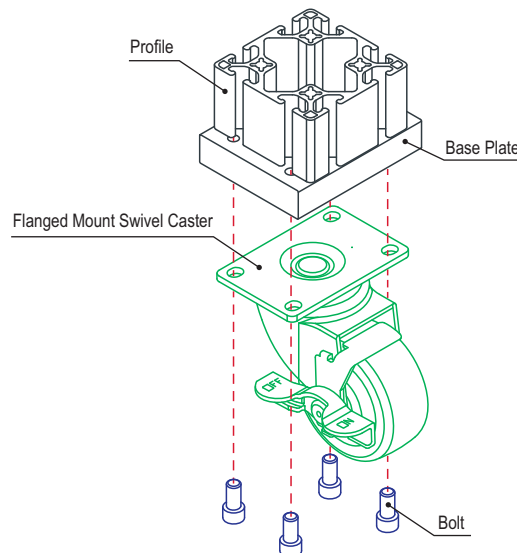

CONTINUE

Flanged Mount Swivel Caster (Continued)

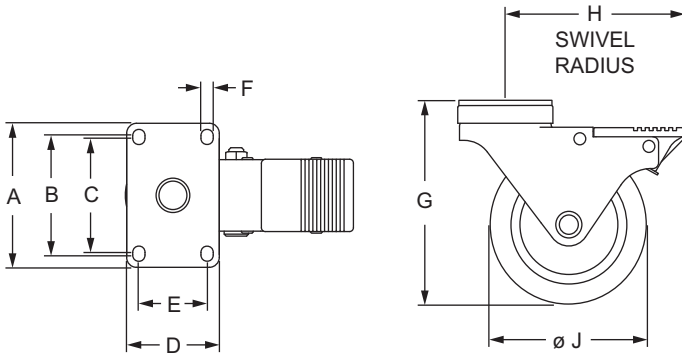

Part No.	Series	Brake	A	B	C	D	E	F	G	H	J	Load Height	Load Capacity	Weight
2321	F	Front	3.625"	3.000"	2.875"	2.375"	1.750"	.328"	5.125"	4.625"	4.000"	5.125"	255.00 lb	1.939 lb
2323	F		3.625"	3.000"	2.875"	2.375"	1.750"	.328"	6.250"	4.625"	5.000"	6.250"	280.00 lb	2.202 lb
65-2321	M		92.08mm	76.20mm	73.03mm	60.33mm	44.45mm	8.33mm	133.18mm	117.48mm	101.60mm	133.18mm	115.67 kg	.8743 kg
65-2323	M		92.08mm	76.20mm	73.03mm	60.33mm	44.45mm	8.33mm	155.58mm	117.48mm	127.00mm	158.45mm	127.01 kg	1.0115 kg

Material Specifications

Material	Finish	Color
Steel / Soft Rubber	Zinc	Black

Suggested Hardware (Mount to Base Plate)

Part No.	Series	Qty.	Bolt
3110	F	4	5/16-18 x 5/8" SHCS
13-8520	M	4	M8 x 20mm SHCS

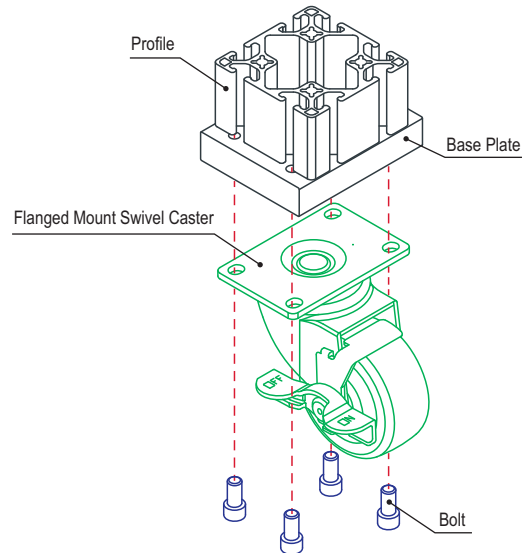

Part Description:

The flange mount rigid caster is a foot that adds mobility to an application and commonly mounts to the T-slot profile end or side using a base plate. This is ideal for use in industrial settings such as mobile carts and material handling solutions. It is commonly used in conjunction with swivel casters to create applications that easily pivot. For base plate options see pages 629-652.

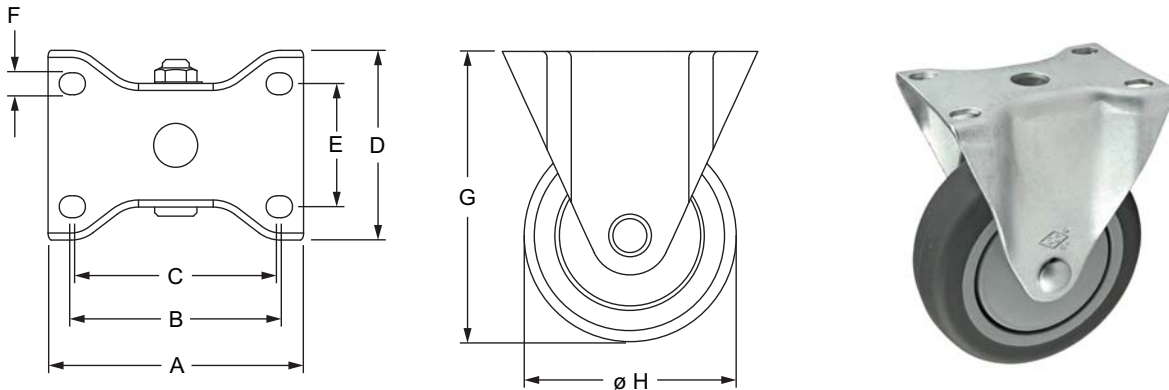

Part No.	Series	A	B	C	D	E	F	G	H	Load Height	Load Capacity	Weight
2311	10 15	3.625"	3.000"	2.875"	2.375"	1.750"	.328"	4.125"	3.000"	4.125"	220.00 lb	1.055 lb
2312	10 15	3.625"	3.000"	2.875"	2.375"	1.750"	.328"	4.125"	3.000"	4.125"	150.00 lb	1.057 lb
2314	10 15	3.625"	3.000"	2.875"	2.375"	1.750"	.328"	5.125"	4.000"	5.125"	255.00 lb	1.151 lb
2316	10 15	3.625"	3.000"	2.875"	2.375"	1.750"	.328"	6.250"	5.000"	6.250"	280.00 lb	1.411 lb
65-2312	25 40	92.08mm	76.20mm	73.03mm	60.33mm	44.45mm	8.33mm	104.78mm	76.20mm	104.78mm	68.04 kg	.4781 kg
65-2314	25 40	92.08mm	76.20mm	73.03mm	60.33mm	44.45mm	8.33mm	130.18mm	101.60mm	130.18mm	115.67 kg	.5130 kg
65-2316	25 40	92.08mm	76.20mm	73.03mm	60.33mm	44.45mm	8.33mm	136.36mm	127.00mm	136.36mm	127.01 kg	.6482 kg

Material Specifications

Part No.	Material	Finish	Color
2311	Steel / Soft Rubber	Zinc	Black
2312	Steel / Hard Rubber		Black
2314	Steel / Soft Rubber		Gray
2316	Steel / Soft Rubber		Gray
65-2312	Steel / Hard Rubber		Black
65-2314	Steel / Soft Rubber		Gray
65-2316	Steel / Soft Rubber		Gray

Suggested Hardware (Mount to Base Plate)

Part No.	Series	Qty.	Bolt
3110	10 15	4	5/16-18 x 5/8" SHCS
13-8520	25 40	4	M8 x 20mm SHCS

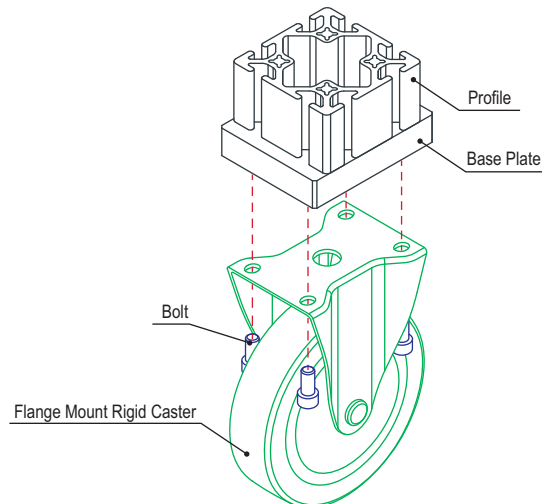

Triangular Top Plate Caster

Part Description:

The triangular top plate caster is a foot that adds mobility to an application and can mount directly to a T-slot profile without a base plate. The slotted holes allow for easy positioning along the profile. The swivel enables easy movement and pivot turns, while the locking tab stops the wheel and the swivel rotation when depressed. The triangular shape provides additional clearance, making it ideal for use in tight spaces.

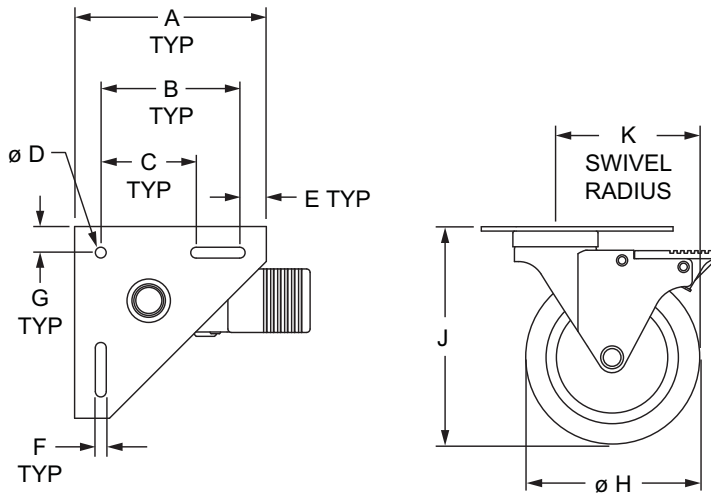

Part No.	Series	A	B	C	D	E	F	G	H	J	K	Load Height	Load Capacity	Weight
2337	15	5.500"	4.000"	2.750"	.313"	.766"	.313"	.750"	4.000"	5.125"	4.625"	5.125"	250.00 lb	2.413 lb
2338	15	5.500"	4.000"	2.750"	.313"	.766"	.313"	.750"	5.000"	6.250"	4.625"	6.250"	300.00 lb	2.664 lb
65-2337	30 40 45	139.70mm	101.60mm	69.85mm	7.95mm	19.46mm	7.95mm	19.05mm	101.60mm	130.18mm	117.48mm	130.18mm	113.64 kg	1.0890 kg
65-2338	30 40 45	139.70mm	101.60mm	69.85mm	7.95mm	19.46mm	7.95mm	19.05mm	127.00mm	158.75mm	117.48mm	158.75mm	136.36 kg	1.2252 kg

Material Specifications

Material	Finish	Color
Steel / Soft Rubber	Zinc	Gray

Suggested Hardware (Mount to T-Slot)

Part No.	Series	Qty.	Bolt	T-Nut
3462	15	3	5/16-18 x 5/8" SHCS, Washer	Economy
75-3620	30	3	M8 x 12mm SHCS	Slide-In
75-3625	40	3	M8 x 16mm SHCS	Slide-In
75-3623	45	3	M8 x 16mm SHCS	Drop-In

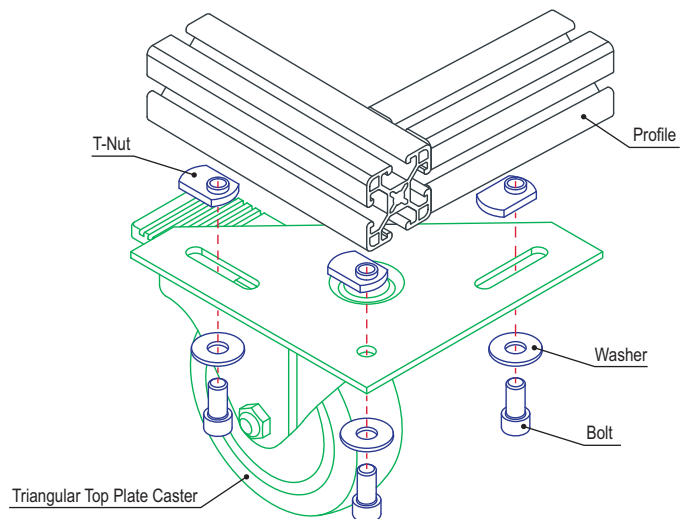

Part Description:

The deluxe flange mount swivel caster is a foot that adds mobility to an application and commonly mounts to the T-slot profile end or side using a base plate. The polyurethane wheels and hardened raceways enable a smooth motion while the swivel allows easy movement and pivot turns. The deluxe flange mount caster includes a brake. It is ideal for use in industrial settings such as mobile carts and material handling solutions. For base plate options see pages 629-652.

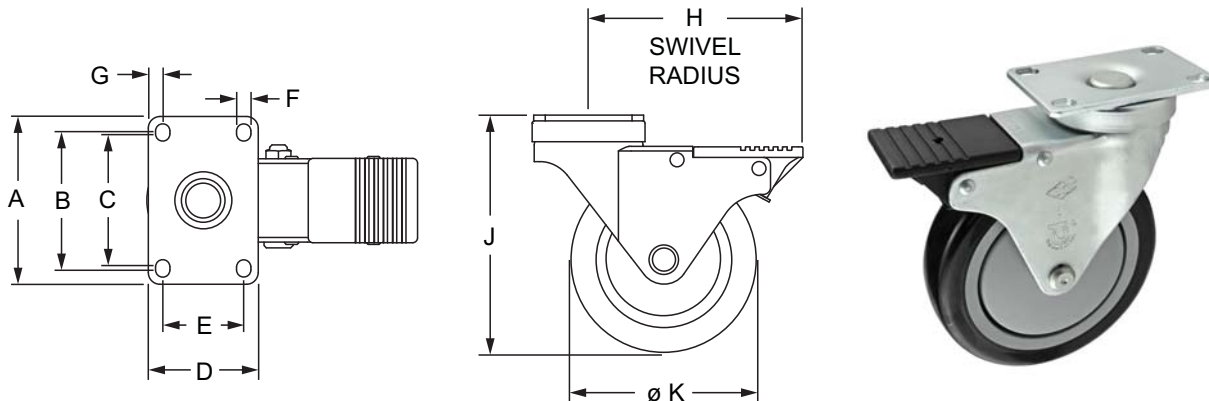

Part No.	Series	A	B	C	D	E	F	G	H	J	K	Load Height	Load Capacity	Weight
2333	F	3.625"	3.000"	2.875"	2.688"	1.750"	.469"	.313"	4.625"	5.125"	4.000"	5.125"	250.00 lb	1.997 lb
2334	F	3.625"	3.000"	2.875"	2.688"	1.750"	.469"	.313"	4.625"	6.250"	5.000"	6.250"	300.00 lb	2.229 lb
65-2333	M	92.08mm	76.20mm	73.03mm	68.28mm	44.45mm	11.91mm	7.94mm	117.48mm	130.18mm	101.60mm	130.18mm	113.64 kg	.9071 kg
65-2334	M	92.08mm	76.20mm	73.03mm	68.28mm	44.45mm	11.91mm	7.94mm	117.48mm	158.75mm	127.00mm	158.75mm	136.36 kg	1.0043 kg

Material Specifications

Material	Finish	Color
Steel / Polyurethane	Zinc	Black on Gray

Suggested Hardware (Mount to Base Plate)

Part No.	Series	Qty.	Bolt
3110	F	4	5/16-18 x 5/8" SHCS
11-8512	M	4	M8 x 12mm SHCS

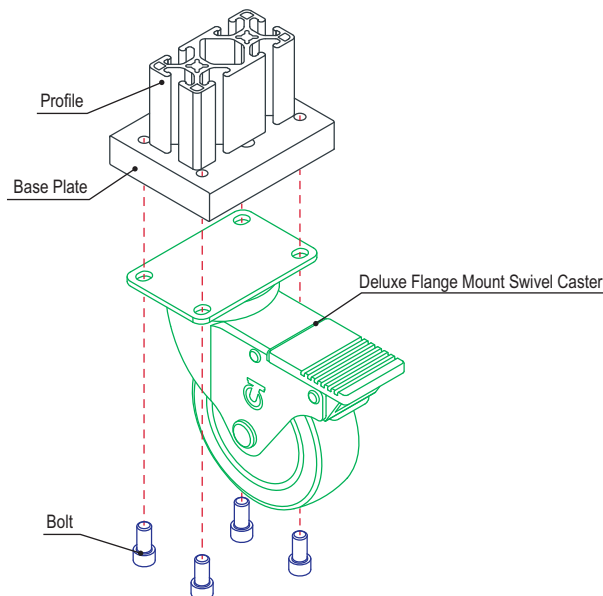

Deluxe Flange Mount Rigid Caster

Part Description:

The deluxe flange mount rigid caster is a foot that adds mobility to an application and commonly mounts to the T-slot profile end or side using a base plate. The polyurethane wheels and hardened raceways enable a smooth motion. It is ideal for use in industrial settings such as mobile carts and material handling solutions. For base plate options see pages 629-652.

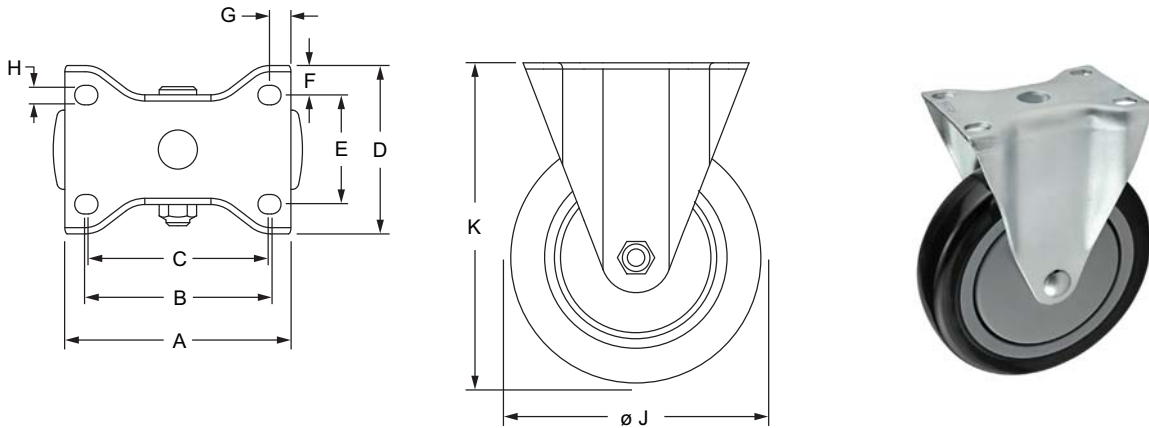

Part No.	Series	A	B	C	D	E	F	G	H	J	K	Load Height	Load Capacity	Weight
2335	F	3.625"	3.000"	2.875"	2.375"	1.750"	.475"	.313"	.328"	4.000"	5.125"	5.125"	300.00 lb	1.164 lb
2336	F	3.625"	3.000"	2.875"	2.375"	1.750"	.475"	.313"	.328"	5.000"	6.250"	6.250"	300.00 lb	1.386 lb
65-2335	M	92.08mm	76.20mm	73.03mm	60.33mm	44.45mm	12.07mm	7.94mm	8.33mm	101.60mm	130.18mm	130.18mm	113.64 kg	.5398 kg
65-2336	M	92.08mm	76.20mm	73.03mm	60.33mm	44.45mm	12.07mm	7.94mm	8.33mm	127.00mm	158.75mm	158.75mm	136.36 kg	.6299 kg

Material Specifications

Material	Finish	Color
Steel / Polyurethane	Zinc	Black on Gray

Suggested Hardware (Mount to Base Plate)

Part No.	Series	Qty.	Bolt
3110	F	4	5/16-18 x 5/8" SHCS
11-8512	M	4	M8 x 12mm SHCS

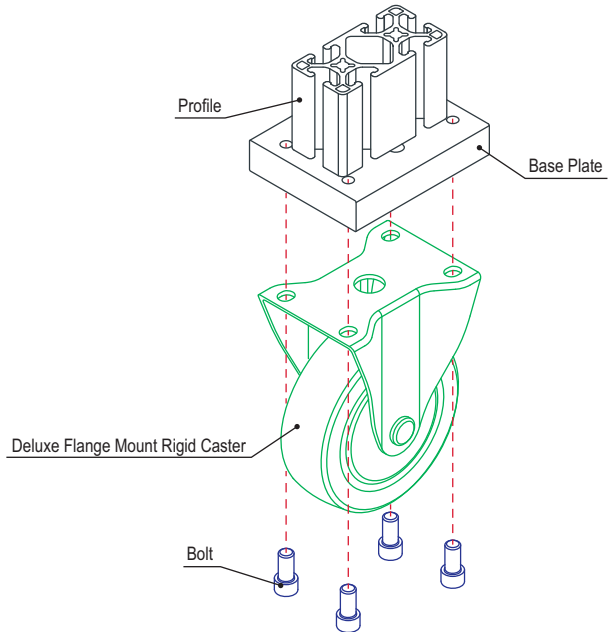

Part Description:

The heavy-duty flange mount swivel caster is a foot that adds mobility to an application and commonly mounts to the T-slot profile end or side using a base plate. The swivel enables easy movement and pivot turns while the design allows for quick access to lubrication fittings. It is a heavy-duty and oil resistant option with a higher ground clearance. It's ideal for use in industrial settings such as large workstations and material handling solutions. For base plate options see pages 629-652.

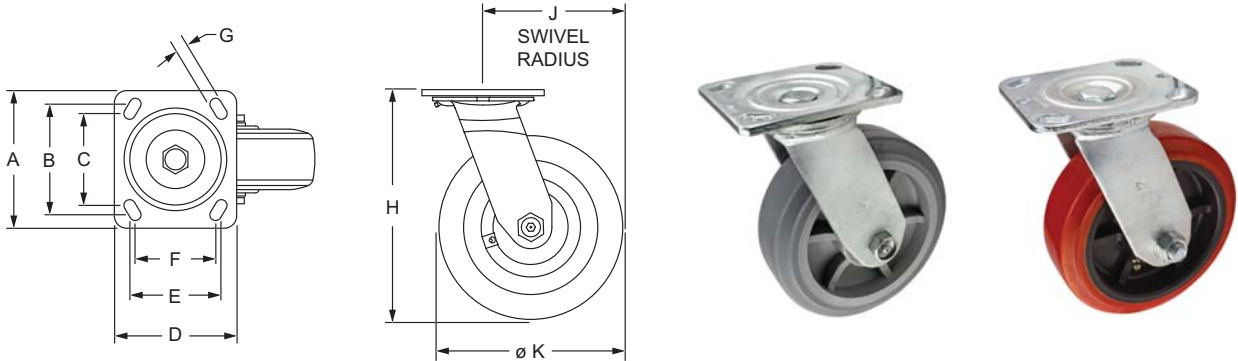

Part No.	Series	A	B	C	D	E	F	G	H	J	K	Load Height	Load Capacity	Weight
2700	F	4.500"	3.625"	3.000"	4.000"	3.000"	2.625"	.420"	6.500"	3.875"	5.000"	6.500"	375.00 lb	4.320 lb
2704	F	4.500"	3.625"	3.000"	4.000"	3.000"	2.625"	.420"	7.500"	4.562"	6.000"	7.500"	550.00 lb	4.585 lb
2708	F	4.500"	3.625"	3.000"	4.000"	3.000"	2.625"	.420"	6.500"	3.875"	5.000"	6.500"	700.00 lb	4.419 lb
2712	F	4.500"	3.625"	3.000"	4.000"	3.000"	2.625"	.420"	7.500"	4.562"	6.000"	7.500"	900.00 lb	4.766 lb
40-2700	M	114.30mm	92.08mm	76.20mm	101.60mm	76.20mm	66.68mm	10.67mm	165.10mm	98.43mm	127.00mm	165.10mm	117.45 kg	2.0126 kg
40-2704	M	114.30mm	92.08mm	76.20mm	101.60mm	76.20mm	66.68mm	10.67mm	190.50mm	115.88mm	152.40mm	190.50mm	250.00 kg	2.0561 kg
40-2708	M	114.30mm	92.08mm	76.20mm	101.60mm	76.20mm	66.68mm	10.67mm	165.10mm	98.43mm	127.00mm	165.10mm	318.18 kg	2.0300 kg
40-2712	M	114.30mm	92.08mm	76.20mm	101.60mm	76.20mm	66.68mm	10.67mm	190.50mm	115.88mm	152.40mm	190.50mm	409.09 kg	2.2244 kg

Material Specifications

Part No.	Material	Finish	Color
2700	Steel / Soft Rubber	Zinc	Gray
2704			
2708	Steel / Hard Rubber		Red on Black
2712			
40-2700	Steel / Soft Rubber		Gray
40-2704			
40-2708	Steel / Hard Rubber	Red on Black	
40-2712			

Suggested Hardware (Mount to Base Plate)

Part No.	Series	Qty.	Bolt
3125	F	4	3/8-16 x 3/4" SHCS
13-1520	M	4	M10 x 20mm SHCS

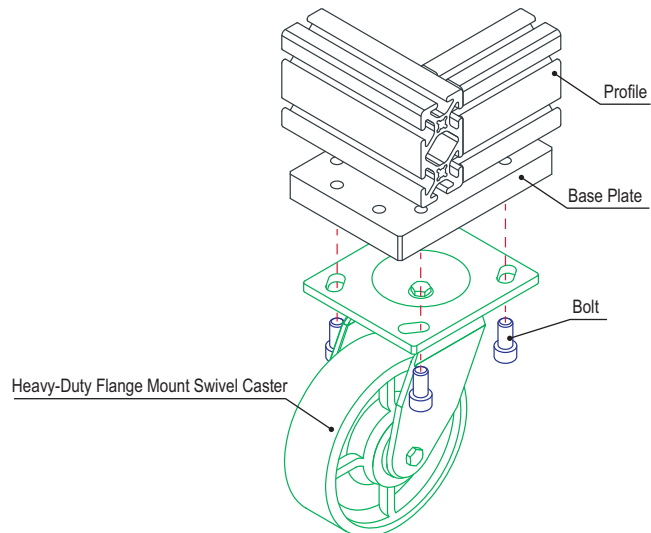

Heavy-Duty Flange Mount Rigid Caster

Part Description:

The heavy-duty flange mount rigid caster is a foot that adds mobility to an application and commonly mounts to the T-slot profile end or side using a base plate. The design allows for easy access to lubrication fittings. It is a heavy-duty and oil resistant option with a higher ground clearance. It's ideal for use in industrial settings such as large workstations and material handling solutions. For base plate options see pages 629-652.

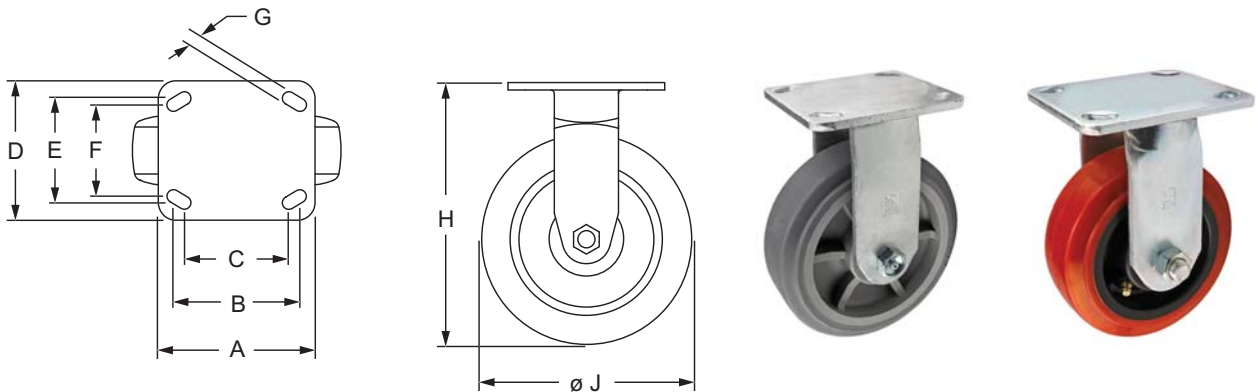

Part No.	Series	A	B	C	D	E	F	G	H	J	Load Height	Load Capacity	Weight
2701	F	4.437"	3.625"	3.000"	4.000"	3.000"	2.625"	.420"	6.500"	5.000"	6.500"	500.00 lb	3.455 lb
2705	F	4.437"	3.625"	3.000"	4.000"	3.000"	2.625"	.420"	7.500"	6.000"	7.500"	500.00 lb	3.716 lb
2709	F	4.437"	3.625"	3.000"	4.000"	3.000"	2.625"	.420"	6.500"	5.000"	6.500"	800.00 lb	3.647 lb
2713	F	4.437"	3.625"	3.000"	4.000"	3.000"	2.625"	.420"	7.500"	6.000"	7.500"	900.00 lb	3.935 lb
40-2701	M	112.70mm	92.08mm	76.20mm	101.60mm	76.20mm	66.68mm	10.67mm	165.10mm	127.00mm	165.10mm	227.27 kg	1.5549 kg
40-2705	M	112.70mm	92.08mm	76.20mm	101.60mm	76.20mm	66.68mm	10.67mm	190.50mm	152.40mm	190.50mm	227.27 kg	1.6883 kg
40-2709	M	112.70mm	92.08mm	76.20mm	101.60mm	76.20mm	66.68mm	10.67mm	165.10mm	127.00mm	165.10mm	363.64 kg	1.6433 kg
40-2713	M	112.70mm	92.08mm	76.20mm	101.60mm	76.20mm	66.68mm	10.67mm	190.50mm	152.40mm	190.50mm	409.09 kg	1.8516 kg

Material Specifications

Part No.	Material	Finish	Color
2701	Steel / Soft Rubber	Zinc	Gray
2705			Red on Black
2709	Steel / Hard Rubber		Red on Black
2713			Gray
40-2701	Steel / Soft Rubber	Zinc	Gray
40-2705			Red on Black
40-2709	Steel / Hard Rubber		Red on Black
40-2713			Gray

Suggested Hardware (Mount to Base Plate)

Part No.	Series	Qty.	Bolt
3125	F	4	3/8-16 x 3/4" SHCS
13-1520	M	4	M10 x 20mm SHCS

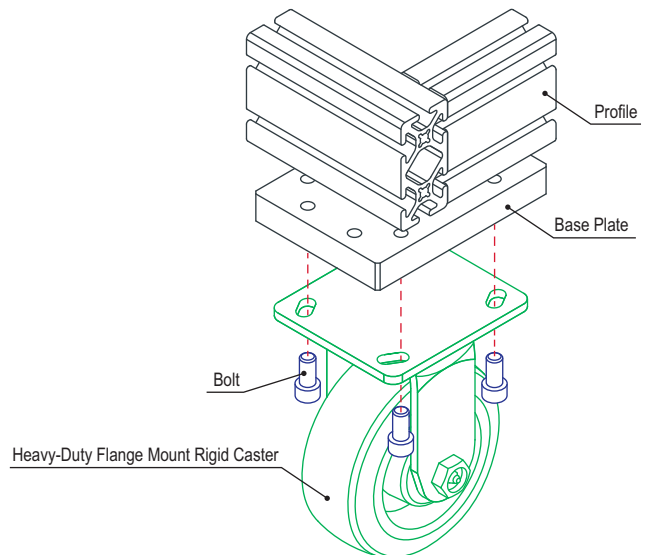



Part Description:

The leveling caster is a foot that incorporates both leveling features and mobility with one component. It is commonly mounted to the end or side of a T-slot profile with a base plate. The leveling caster is available in four sizes. It is ideal for large machine and automation frames. For base plate options see pages 629-652.

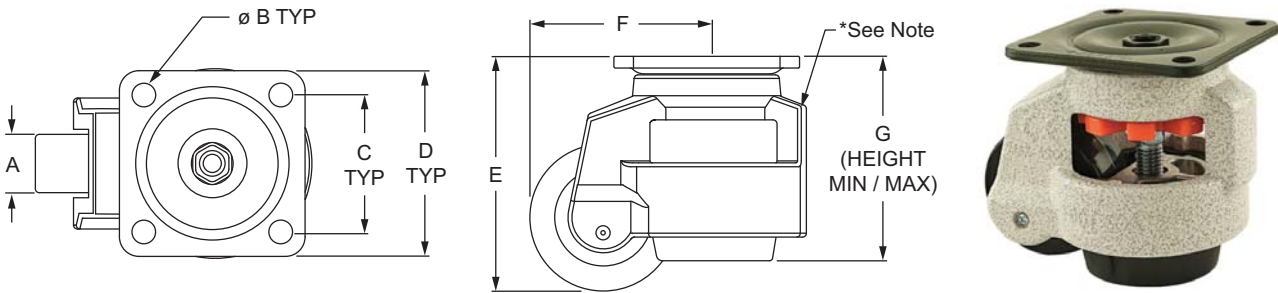

Part No.	Series	A	B	C	D	E	F	G	Load Capacity	Weight
2714	F	.945"	.276"	2.283"	2.874"	3.228"	2.362"	2.700" / 3.650"	550.00 lb	1.620 lb
2715	F	1.142"	.315"	2.756"	3.543"	4.020"	3.051"	3.429" / 4.606"	1100.00 lb	2.943 lb
2716	F	1.193"	.433"	2.756"	3.740"	4.724"	3.563"	4.035" / 5.197"	1650.00 lb	3.950 lb
2717*	F	1.220"	.433"	2.756"	3.740"	4.724"	3.563"	4.250" / 4.875"	2200.00 lb	4.607 lb
65-2714	M	24.00mm	7.00mm	58.00mm	73.00mm	82.00mm	60.00mm	68.70mm / 92.70mm	249.47 kg	.7542 kg
40-2715	M	29.00mm	8.00mm	70.00mm	90.00mm	102.00mm	77.50mm	87.10mm / 117.00mm	498.95 kg	1.3045 kg
40-2716	M	30.30mm	11.00mm	70.00mm	95.00mm	120.00mm	90.50mm	102.50mm / 132.00mm	748.42 kg	1.7917 kg
40-2717*	M	31.00mm	11.00mm	70.00mm	95.00mm	119.90mm	90.50mm	107.95mm / 123.83mm	997.90 kg	2.0403 kg

*Center bar not available

Material Specifications

Material	Finish	Color
Die Cast Aluminum / Plastic Nylon (Nylon 6)	Powder Coat Over Zinc	Black

Suggested Hardware (Mount to Base Plate)

Caster No.	Series	Base Plate	Bolt Kit	Bolt Kit Qty.
2714	F	2406 / 2407	3064	4
2715	F	2408	3112	4
2716	F	2409	3125	4
2717	F	2409	3125	4
65-2714	M	25-2406 / 40-2407	13-6520	4
40-2715	M	40-2408	13-6520	4
40-2716	M	40-2409	13-6520	4
40-2717	M	40-2409	13-6520	4

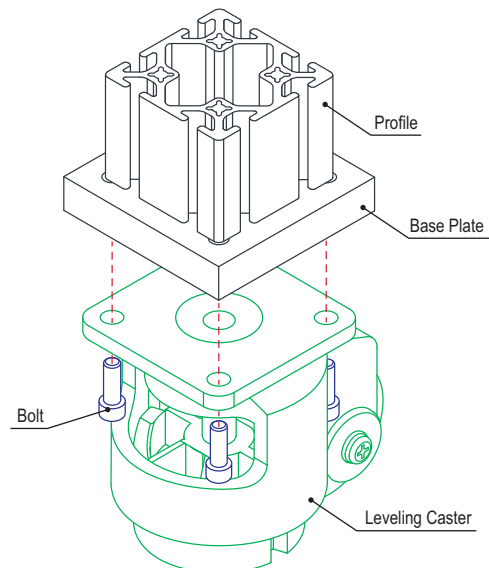

Adjustable Position Floor Lock

Part Description:

The adjustable position floor lock uses a spring-loaded rubber foot pad to immobilize equipment. It is commonly used to keep frames from shifting and has a foot that can adjust up to 2.75" (69.85mm), allowing greater design flexibility. The adjustable position floor lock has a foot release lever and commonly mounts to a T-slot profile side using a position floor lock base plate. There is a minimum weight requirement of 70 pounds (400 kilograms) necessary to properly immobilize equipment. By adjusting the tension nut, the holding force can be increased from 70 to 120 pounds (400-534 kilograms). For base plate options see pages 629-652.

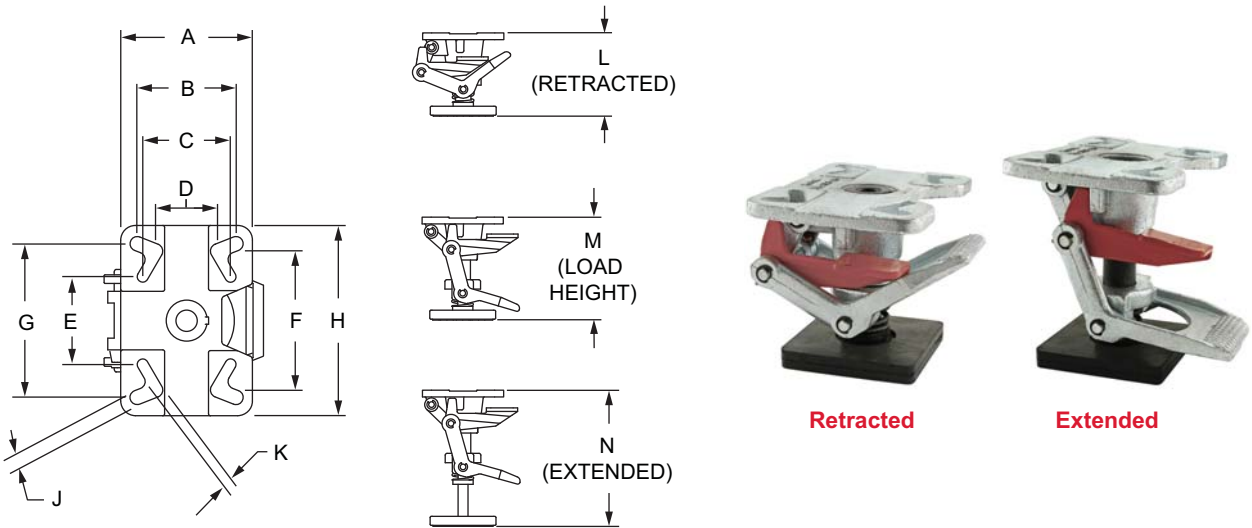

Part No.	Series	A	B	C	D	E	F	G	H	J	K	L	M	N	Load Capacity	Weight
2731	F	4.500"	3.400"	3.000"	2.100"	3.000"	4.750"	5.250"	6.500"	.490"	.380"	4.500"	5.500"	7.500"	120.00 lb	7.115 lb
40-2731	M	114.30mm	86.36mm	76.20mm	53.34mm	76.20mm	120.65mm	133.35mm	165.10mm	12.45mm	9.66mm	114.30mm	139.70mm	190.50mm	534.00 kg	3.233 kg

Material Specifications

Material	Finish
Steel Casting	Paint

Suggested Hardware (Mount to Base Plate)

Part No.	Series	Qty.	Bolt
3289	F	4	3/8-16 x 1.00" SHCS & Washer
13-1525	M	4	M10 x 25mm SHCS & Washer

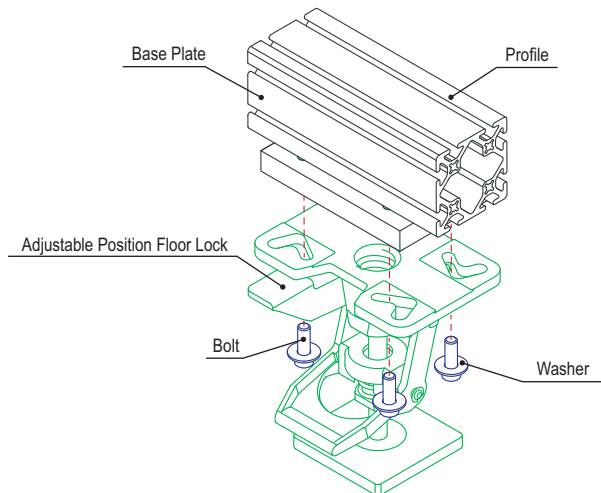

Part Description:

The standard floor glide is made of black nylon and has a 100 pound (45.36 kilogram) load capacity. The non-corrosive threaded stem can mount directly to the T-slot profile end or to the side or end using a base plate. It is a medium-duty foot that works well on carpet or tiled areas, making it ideal for home and office furniture, desks, stands and tables.



2203



2204

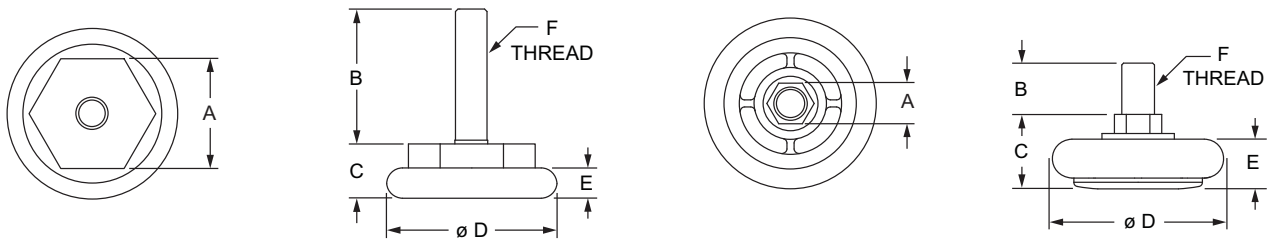

Part No.	Series	Material	Finish	Color	A	B	C	D	E	F	Load Capacity	Weight
2203	F	Steel / Nylon	Zinc	Black	.875"	1.070"	.430"	1.350"	.240"	1/4-20	100.00 lb	.033 lb
2204	F				.470"	.593"	.860"	1.968"	.575"	3/8-16	100.00 lb	.088 lb

Required Machining Services

Machining Type	Machined	Reference Page
Tap Profile End	Mounting Profile	853

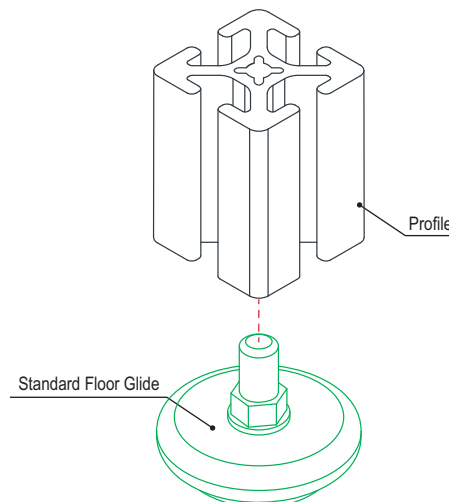

Economy Floor Glide

Part Description:

The economy floor glide is nickel-plated with a non-abrasive nylon base. It can mount directly to the T-slot profile end or to the side or end using a base plate. It is a medium-duty foot with load capacity options ranging from 250-500 pounds (113-227 kilograms). It works well on a variety of surfaces such as concrete or carpet, making it ideal for industrial, office, or home solutions.

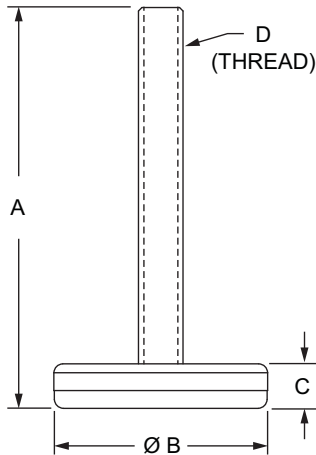

Part No.	Series	Color	A	B	C	D	Load Capacity	Weight
2186	F	Bright / Natural	2.250"	1.200"	.378"	1/4-20	250.00 lb	.042 lb
2187	F		2.840"	2.030"	.460"	5/16-18	250.00 lb	.118 lb
2188	F		3.030"	2.400"	.530"	3/8-16	250.00 lb	.169 lb
2189	F		3.030"	2.800"	.542"	1/2-13	500.00 lb	.258 lb
25-2186	M		57.20mm	31.00mm	9.60mm	M6 x 1.0	113.00 kg	.0188 kg
65-2187	M		57.20mm	52.00mm	11.80mm	M8 x 1.25	113.00 kg	.0501 kg
65-2188	M		75.40mm	61.00mm	13.40mm	M10 x 1.5	113.00 kg	.0806 kg
65-2189	M		77.00mm	72.00mm	13.76mm	M12 x 1.75	227.00 kg	.1142 kg

Material Specifications

Material	Process	Finish
Steel / Nylon	Machined	Nickel

Required Machining Services

Machining Type	Machined	Reference Page
Tap Profile End	Mounting Profile	853

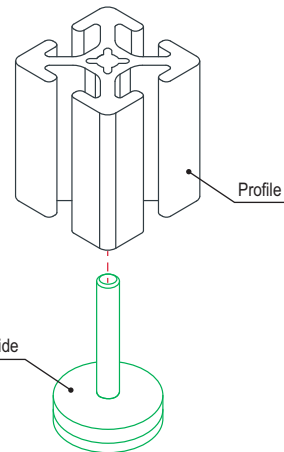

Part Description:

The large base glide is a foot with load capacity options ranging up to 5000 pounds (2175 kilograms). It mounts with a base plate and works well for leveling heavier applications. The large base diameter creates maximum surface area while allowing a 15 degree swivel in all directions, making it perfect for industrial applications. The glide includes punch out mounting holes for anchoring or bolting to the floor, great for guards and machine frames. See more about floor anchors on page 623. For information on base plates see pages 629-652.

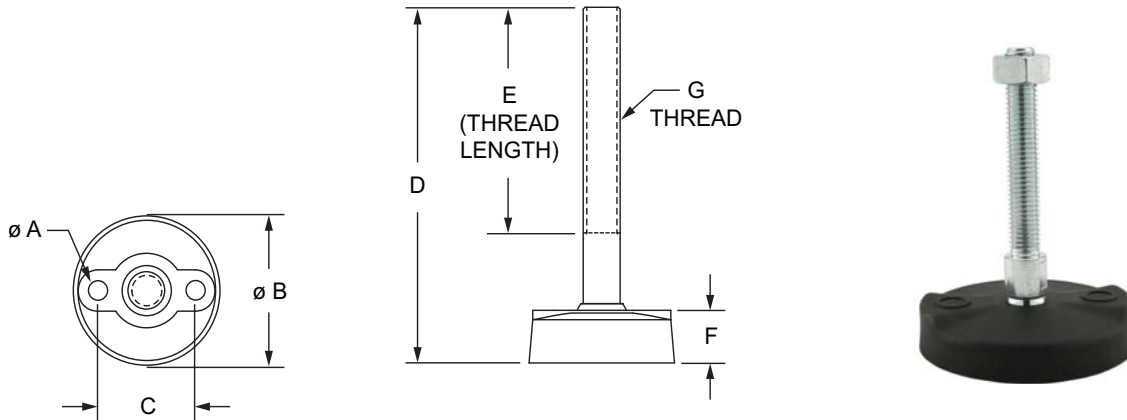

Part No.	Series	A	B	C	D	E	F	G	Load Capacity	Weight
2183	F	.272"	1.970"	1.320"	4.290"	3.000"	.730"	3/8-16	4000.00 lb	.236 lb
2184	F	.272"	1.970"	1.320"	4.290"	3.000"	.730"	1/2-13	4000.00 lb	.316 lb
2181	F	.354"	3.150"	2.165"	4.290"	3.000"	.730"	3/8-16	5000.00 lb	.304 lb
2182	F	.354"	3.150"	2.165"	4.290"	3.000"	.730"	1/2-13	5000.00 lb	.383 lb
65-2183	M	6.50mm	50.80mm	33.30mm	110.00mm	75.00mm	18.00mm	M10 x 1.50	1740.00 kg	.1128 kg
65-2184	M	6.50mm	50.80mm	33.30mm	110.00mm	75.00mm	18.00mm	M12 x 1.75	1740.00 kg	.1245 kg
65-2178	M	6.50mm	50.80mm	33.30mm	135.00mm	100.00mm	18.00mm	M16 x 2.00	1740.00 kg	.2227 kg
65-2181	M	9.00mm	76.20mm	55.00mm	110.00mm	75.00mm	18.00mm	M10 x 1.50	2175.00 kg	.1676 kg
65-2182	M	9.00mm	76.20mm	55.00mm	110.00mm	75.00mm	18.00mm	M12 x 1.75	2175.00 kg	.1626 kg
65-2179	M	9.00mm	76.20mm	55.00mm	135.00mm	100.00mm	18.00mm	M16 x 2.00	2175.00 kg	.2580 kg

Material Specifications

Material	Process	Finish	Color
Steel / Elastomer Rubber	Injection Molded	Zinc / Matte	Bright / Black

Required Machining Services

Machining Type	Machined	Reference Page
Tap Profile End	Mounting Profile	853

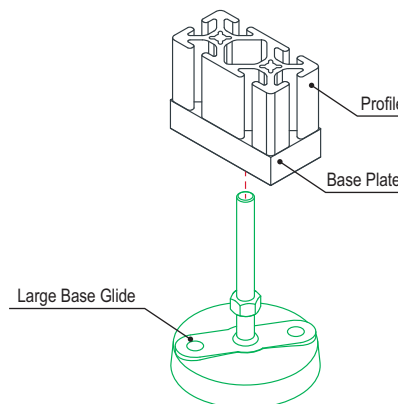

Mighty Mount[®]

Part Description:

The Mighty Mount[®] is a foot with a high level of vibration and shock isolation. It has a non-skid elastomer pad with options available of up to 4200 pounds (453 kilograms). The Mighty Mount[®] has a powder coated safety-yellow steel housing and is a heavy-duty option, perfect for industrial applications such as machine framing, automation solutions, and guards. It is recommended for use with leveling anchor base plates found on pages 629-652.

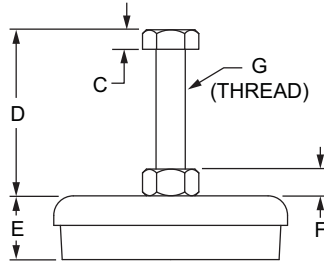
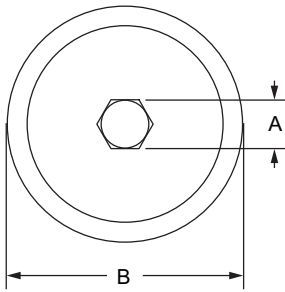

Part No.	Series	A	B	C	D	E	F	G	Load Capacity	Weight
2215	F	.563"	3.000"	.250"	2.250"	1.500"	.375"	3/8-16	300.00 lb	.902 lb
2205	F	.563"	3.000"	.250"	2.250"	1.500"	.375"	3/8-24	300.00 lb	1.038 lb
2216	F	.750"	5.000"	.375"	4.250"	1.500"	.438"	1/2-13	1500.00 lb	2.474 lb
2217	F	1.125"	6.000"	.500"	4.250"	1.630"	.688"	3/4-10	4200.00 lb	5.086 lb
25-2205	M	17.00mm	75.00mm	8.38mm	65.00mm	40.00mm	8.38mm	M10 x 1.50	136.00 kg	.4783 kg
40-2206	M	18.80mm	116.00mm	11.20mm	119.50mm	40.00mm	9.90mm	M12 x 1.75	453.00 kg	1.0700 kg

Material Specifications

Material	Process	Finish	Color
Steel / Elastomer Rubber	Cold Rolled Sheet / Coil Steel Formed	Zinc / Powder Coated	Bright / Yellow / Black

Required Machining Services

Machining Type	Machined	Reference Page
Tap Profile End	Mounting Profile	853

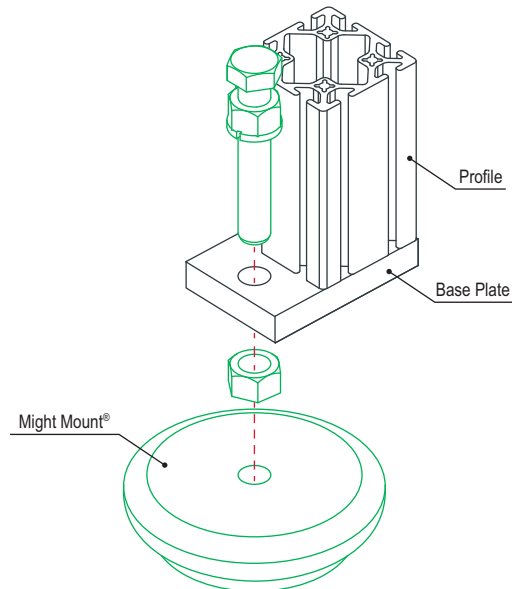

Part Description:

The economy anti-vibration mount is a foot that pivots 20 degrees to accommodate uneven floors. It has a rubber pad to provide resistance to vibration, making it useful for high-precision projects or computerized machinery. There are options available with load capacities ranging from 200-1250 pounds and 23-148 kilograms. It mounts using a base plate (pages 629-652) and requires an end tap in the profile (page 853).

Additional Information: The economy anti-vibration mount comes with a jam nut.

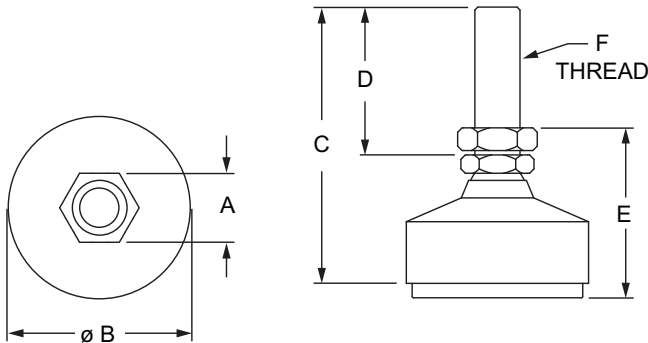

Part No.	Series	Color	A	B	C	D	E	F	Load Capacity	Weight
2207	F	Yellow	.562"	1.250"	3.500"	2.000"	1.500"	3/8-16	200.00 lb	.346 lb
2208	F		.625"	1.875"	3.750"	2.000"	1.750"	1/2-13	500.00 lb	.816 lb
2209	F		1.062"	3.000"	4.125"	2.000"	2.125"	3/4-10	1250.00 lb	2.407 lb
65-2207	M		16.00mm	32.00mm	89.00mm	51.00mm	48.00mm	M10 x 1.50	23.00 kg	.1711 kg
65-2208	M		19.00mm	48.00mm	95.00mm	51.00mm	53.00mm	M12 x 1.75	54.00 kg	.3574 kg
65-2215	M		22.00mm	64.00mm	99.00mm	51.00mm	58.00mm	M16 x 2.00	100.00 kg	.6950 kg
65-2209	M		27.00mm	76.00mm	105.00mm	51.00mm	68.00mm	M20 x 2.50	148.00 kg	1.0991 kg

Material Specifications

Material	Grade	Process	Finish
Steel	12L14	Machined	Zinc

Required Machining Services

Machining Type	Machined	Reference Page
Tap Profile End	Mounting Profile	853

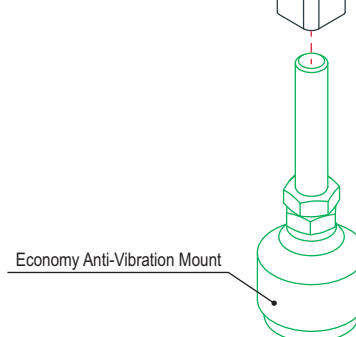
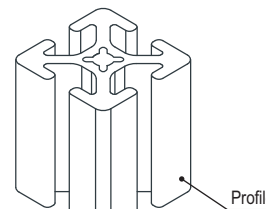

Deluxe Leveling Foot

Part Description:

The deluxe leveling foot has a jam nut that allows it to pivot 20 degrees to accommodate uneven floors. There are options available with load capacities ranging from 1000-7400 pounds (317-3357 kilograms). The deluxe leveling foot is a heavy-duty option ideal for large structures and commonly mounts to a profile with a base plate (pages 629-652).

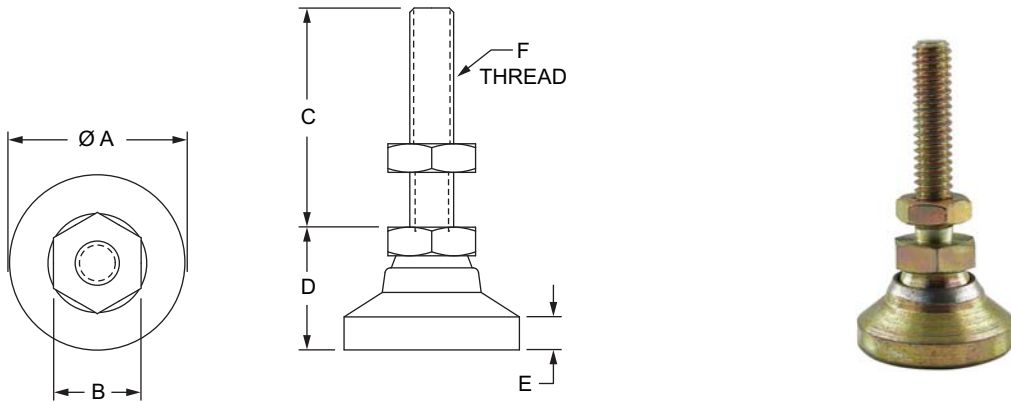

Part No.	Series	Color	A	B	C	D	E	F	Load Capacity	Weight
2192	F	Yellow	1.000"	.500"	1.250"	.703"	.156"	1/4-20	1000.00 lb	.1042 lb
2194	F		1.250"	.625"	2.000"	.875"	.188"	5/16-18	2300.00 lb	.1966 lb
2190	F		1.250"	.625"	2.000"	.875"	.188"	3/8-16	3750.00 lb	.2160 lb
2200	F		1.875"	.750"	2.000"	1.125"	.250"	1/2-13	5000.00 lb	.4940 lb
2202	F		3.000"	1.062"	2.000"	1.500"	.500"	3/4-10	7400.00 lb	1.6930 lb
25-2192	M		19.00mm	10.00mm	25.00mm	14.00mm	2.50mm	M6 x 1.00	317.00 kg	.0213 kg
65-2212	M		26.00mm	13.00mm	32.00mm	18.00mm	3.50mm	M8 x 1.25	453.00 kg	.0487 kg
65-2190	M		32.00mm	16.00mm	51.00mm	22.00mm	4.00mm	M10 x 1.50	1701.00 kg	.1049 kg
65-2200	M		48.00mm	19.00mm	51.00mm	29.00mm	5.50mm	M12 x 1.75	2268.00 kg	.2183 kg
65-2213	M		64.00mm	22.00mm	51.00mm	32.00mm	8.00mm	M16 x 2.00	2721.00 kg	.4490 kg
65-2202	M		76.00mm	27.00mm	51.00mm	38.00mm	10.00mm	M20 x 2.50	3357.00 kg	.7580 kg

Material Specifications

Material	Grade	Process	Finish
Steel	12L14	Machined	Zinc

Required Machining Services

Machining Type	Machined	Reference Page
Tap Profile End	Mounting Profile	853

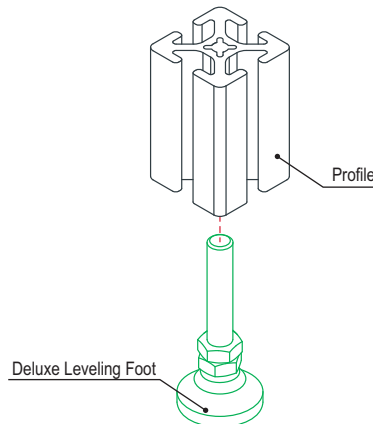



Part Description:

The economy leveling foot includes a jam nut to accommodate uneven floors. It is a cost-effective option ideal for heavy-duty projects. There are options available with load capacities ranging from 1050-4700 pounds (475-2130 kilograms). The economy leveling foot can be mounted directly to a profile end or to the side or end with a base plate (pages 629-652). For tapping services see page 853.

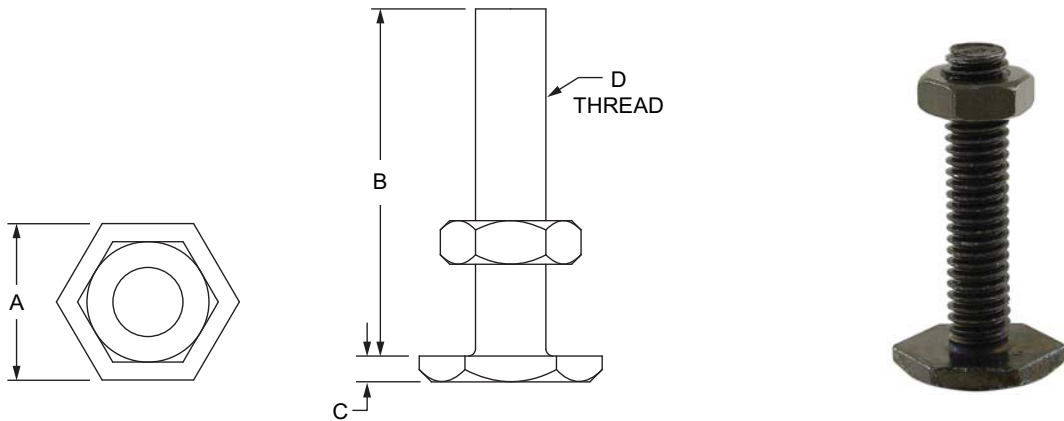

Part No.	Series	Material	Grade	Process	Finish	Color	A	B	C	D	Load Capacity	Weight
2193	F	Steel	C1010	Cold Formed	Zinc	Black	.563"	1.250"	.094"	1/4-20	1050.00 lb	.025 lb
2195	F						.750"	1.500"	.109"	5/16-18	1750.00 lb	.046 lb
2191	F						.875"	2.000"	.141"	3/8-16	2550.00 lb	.082 lb
2201	F						1.063"	2.500"	.172"	1/2-13	4700.00 lb	.180 lb
25-2193	M					14.00mm	30.00mm	2.40mm	M6 x 1.00	475.00 kg	.0089 kg	
65-2195	M					18.00mm	40.00mm	3.10mm	M8 x 1.25	790.00 kg	.0213 kg	
65-2191	M					22.00mm	60.00mm	3.70mm	M10 x 1.50	1150.00 kg	.0471 kg	
65-2201	M					25.00mm	63.00mm	4.40mm	M12 x 1.75	2130.00 kg	.0721 kg	

Required Machining Services

Machining Type	Machined	Reference Page
Tap Profile End	Mounting Profile	853

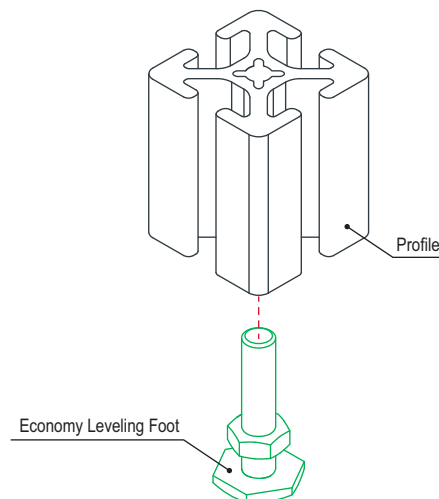

Swivel Foot Base

Part Description:

The swivel foot base is made of stainless steel. It is a heavy-duty leveling foot with a rubber pad that provides resistance to vibration, making it useful for precision applications. There are load capacity options available ranging from 4400-8800 pounds (1995.80-3991.61 kilograms). The swivel foot base requires a threaded stem; see pages 618-619.

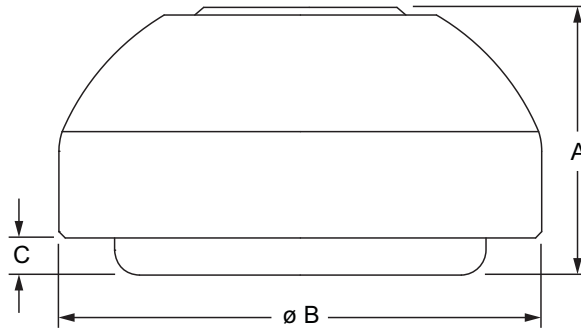

Part No.	Series	Material	Process	Finish	Color	A	B	C	Load Capacity	Weight
12170	F M	Stainless-Steel / Thermoplastic Elastomer	Metal Injection Molded	Stainless	Satin / Black	20.00mm	29.00mm	2.00mm	1995.80 kg	.0670 kg
12172	F M					20.00mm	39.00mm	2.00mm	2993.71 kg	.1092 kg
12174	F M					20.00mm	44.00mm	2.00mm	2993.71 kg	.1300 kg
12176	F M					20.00mm	49.00mm	2.00mm	3492.66 kg	.1680 kg
12178	F M					20.00mm	59.00mm	2.00mm	3492.66 kg	.2324 kg
12182	F M					20.00mm	79.00mm	2.00mm	3991.61 kg	.4065 kg
12186	F M					20.00mm	99.00mm	2.00mm	3991.61 kg	.6451 kg

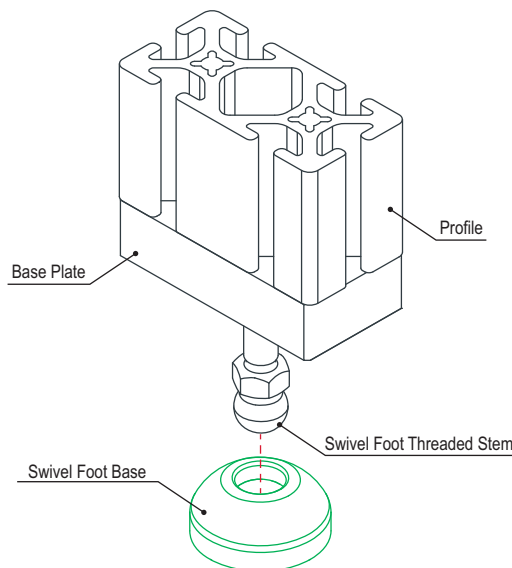

Part Description:

The swivel foot base with mount holes is made of stainless steel. It is a heavy-duty leveling foot with a rubber pad that provides resistance to vibration, making it useful for precision applications. There are options available with load capacities ranging from 6600-8800 pounds (2993.71-3991.61 kilograms). The holes enable mounting of the fixture directly to a concrete floor. See page 623 for information on floor anchors. It requires a threaded stem; see pages 618-619.

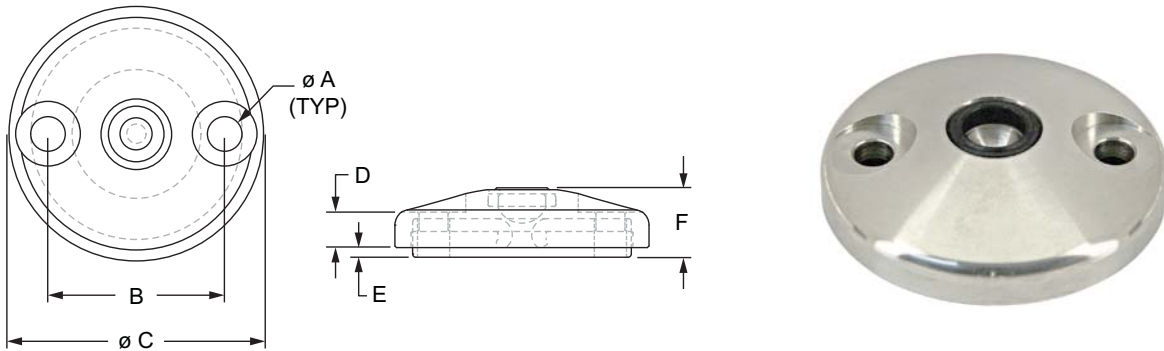

Part No.	Series	A	B	C	D	E	F	Load Capacity	Weight
12181	F M	9.00mm	55.00mm	79.00mm	11.00mm	2.00mm	20.00mm	2993.71 kg	.3865 kg
12185	F M	9.00mm	74.00mm	99.00mm	11.00mm	2.00mm	20.00mm	3991.61 kg	.6238 kg

Material Specifications

Material	Process	Finish	Color
Stainless-Steel / Thermoplastic Elastomer	Metal Injection Molded	Stainless	Satin / Black

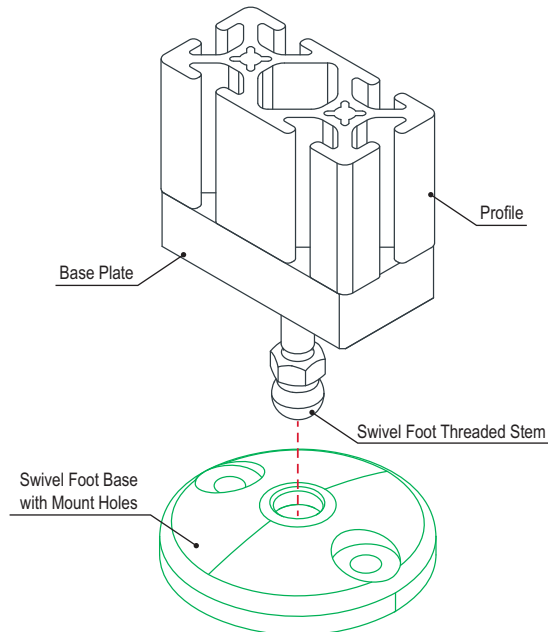

Swivel Foot Threaded Stem

Part Description:

The swivel foot threaded stem is used with swivel bases and is available in zinc-plated or stainless steel. There are options for medium or heavy-duty applications.

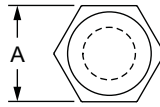
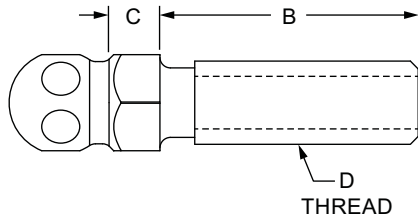

Part No.	Series	Material	Grade	Process	Finish	Color	A	B	C	D	Load Capacity	Weight
12211	F	Steel	5.8	Machined	Zinc	Bright	.551"	—	.295"	1/4-20	400.00 lb	.047 lb
12229	F	Stainless-Steel	304		Stainless	Natural	9/16	1.500"	.295"	1/4-20	400.00 lb	.069 lb
12230	F	Steel	5.8		Zinc	Bright	9/16	1.500"	.295"	1/4-20	400.00 lb	.070 lb
12245	F	Stainless-Steel	304		Stainless	Natural	9/16	1.500"	.295"	5/16-18	700.00 lb	.081 lb
12246	F	Steel	5.8		Zinc	Bright	9/16	1.500"	.295"	5/16-18	700.00 lb	.078 lb
12247	F	Stainless-Steel	304		Stainless	Natural	9/16	2.500"	.295"	5/16-18	700.00 lb	.094 lb
12248	F	Steel	5.8		Zinc	Bright	9/16	2.500"	.295"	5/16-18	700.00 lb	.093 lb
12249	F	Stainless-Steel	304		Stainless	Natural	9/16	3.500"	.295"	5/16-18	700.00 lb	.111 lb
12250	F	Steel	5.8		Zinc	Bright	9/16	3.500"	.295"	5/16-18	700.00 lb	.120 lb
12237	F	Stainless-Steel	304		Stainless	Natural	9/16	1.500"	.295"	3/8-16	1000.00 lb	.092 lb
12238	F	Steel	5.8		Zinc	Bright	9/16	1.500"	.295"	3/8-16	1000.00 lb	.090 lb
12239	F	Stainless-Steel	304		Stainless	Natural	9/16	2.500"	.295"	3/8-16	1000.00 lb	.113 lb
12240	F	Steel	5.8		Zinc	Bright	9/16	2.500"	.295"	3/8-16	1000.00 lb	.112 lb
12241	F	Stainless-Steel	304		Stainless	Natural	9/16	4.000"	.295"	3/8-16	1000.00 lb	.154 lb
12242	F	Steel	5.8		Zinc	Bright	9/16	4.000"	.295"	3/8-16	1000.00 lb	.147 lb
12243	F	Stainless-Steel	304		Stainless	Natural	9/16	6.000"	.295"	3/8-16	1000.00 lb	.200 lb
12213	F	Stainless-Steel	304		Stainless	Natural	9/16	1.500"	.295"	1/2-13	1600.00 lb	.112 lb
12215	F	Stainless-Steel	304		Stainless	Natural	9/16	2.500"	.295"	1/2-13	1600.00 lb	.162 lb
12216	F	Steel	5.8		Zinc	Bright	9/16	2.500"	.295"	1/2-13	1600.00 lb	.162 lb
12217	F	Stainless-Steel	304		Stainless	Natural	9/16	2.000"	.295"	1/2-13	1600.00 lb	.140 lb
12218	F	Steel	5.8		Zinc	Bright	9/16	2.000"	.295"	1/2-13	1600.00 lb	.143 lb
12221	F	Stainless-Steel	304		Stainless	Natural	9/16	3.000"	.295"	1/2-13	1600.00 lb	.188 lb
12222	F	Steel	5.8	Zinc	Bright	9/16	3.000"	.295"	1/2-13	1600.00 lb	.179 lb	

CONTINUE



Swivel Foot Threaded Stem (Continued)

Part No.	Series	Material	Grade	Process	Finish	Color	A	B	C	D	Load Capacity	Weight
12223	F	Stainless-Steel	304	Machined	Stainless	Natural	9/16	4.000"	.295"	1/2-13	1600.00 lb	.234 lb
12224	F	Steel	5.8		Zinc	Bright	9/16	4.000"	.295"	1/2-13	1600.00 lb	.229 lb
12227	F	Stainless-Steel	304		Stainless	Natural	9/16	6.000"	.295"	1/2-13	1600.00 lb	.312 lb
12228	F	Steel	5.8		Zinc	Bright	9/16	6.000"	.295"	1/2-13	1600.00 lb	.322 lb
12231	F	Stainless-Steel	304		Stainless	Natural	7/8	4.000"	.413"	3/4-10	5300.00 lb	.518 lb
12232	F	Steel	5.8		Zinc	Bright	7/8	4.000"	.413"	3/4-10	5300.00 lb	.508 lb
12233	F	Stainless-Steel	304		Stainless	Natural	7/8	6.000"	.413"	3/4-10	5300.00 lb	.731 lb
12234	F	Steel	5.8		Zinc	Bright	7/8	6.000"	.413"	3/4-10	5300.00 lb	.723 lb
12195	M	Stainless-Steel	304		Stainless	Natural	14.00mm	40.00mm	7.50mm	M8 x 1.25	318.00 kg	.0363 kg
12390	M	Steel	5.8		Zinc	Bright	14.00mm	40.00mm	7.50mm	M8 x 1.25	318.00 kg	.0358 kg
12392	M	Steel	5.8		Zinc	Bright	14.00mm	80.00mm	7.50mm	M8 x 1.25	318.00 kg	.0484 kg
12197	M	Stainless-Steel	304		Stainless	Natural	14.00mm	45.00mm	7.50mm	M10 x 1.50	454.00 kg	.0459 kg
12394	M	Steel	5.8		Zinc	Bright	14.00mm	45.00mm	7.50mm	M10 x 1.50	454.00 kg	.0456 kg
12198	M	Stainless-Steel	304		Stainless	Natural	14.00mm	90.00mm	7.50mm	M10 x 1.50	454.00 kg	.0671 kg
12396	M	Steel	5.8		Zinc	Bright	14.00mm	90.00mm	7.50mm	M10 x 1.50	454.00 kg	.0680 kg
12200	M	Stainless-Steel	304		Stainless	Natural	14.00mm	45.00mm	7.50mm	M12 x 1.75	726.00 kg	.0563 kg
12400	M	Steel	5.8		Zinc	Bright	14.00mm	45.00mm	7.50mm	M12 x 1.75	726.00 kg	.0555 kg
12201	M	Stainless-Steel	304		Stainless	Natural	14.00mm	100.00mm	7.50mm	M12 x 1.75	726.00 kg	.0963 kg
12402	M	Steel	5.8		Zinc	Bright	14.00mm	100.00mm	7.50mm	M12 x 1.75	726.00 kg	.0953 kg
12203	M	Stainless-Steel	304		Stainless	Natural	17.00mm	66.00mm	7.50mm	M16 x 2.00	1406.00 kg	.1133 kg
12204	M	Stainless-Steel	304		Stainless	Natural	17.00mm	125.00mm	7.50mm	M16 x 2.00	1406.00 kg	.1919 kg
12408	M	Steel	5.8		Zinc	Bright	17.00mm	125.00mm	7.50mm	M16 x 2.00	1406.00 kg	.1883 kg

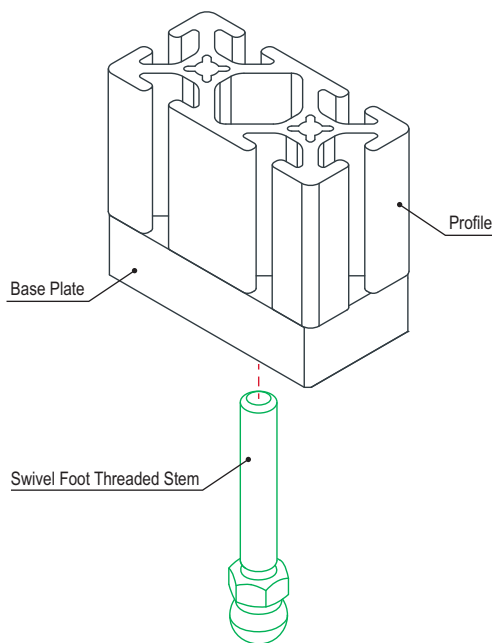

Swivel Foot Extended Base

Part Description:

The swivel foot extended base is a heavy-duty leveling foot with a powder coat which provides extra durability. The extension includes a through-hole to secure directly to a solid concrete floor with a wedge floor anchor (page 623). This base requires a swivel foot threaded stem (page 618-619).

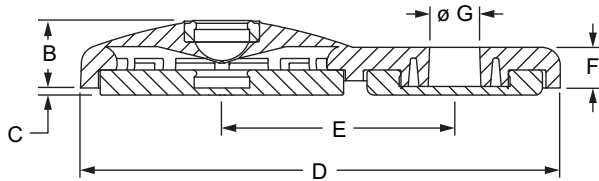
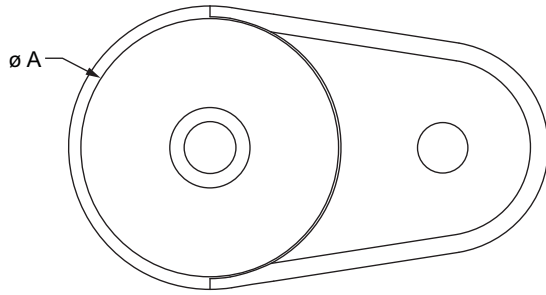

Part No.	Series	Color	A	B	C	D	E	F	G	Load Capacity	Weight
12192	F M	Black	3.110"	.709"	.079"	5.275"	2.559"	.445"	.551"	6600.00 lb	.969 lb

Material Specifications

Material	Process	Finish
Die Cast Zinc	Die-Casting	Black Powder Coated

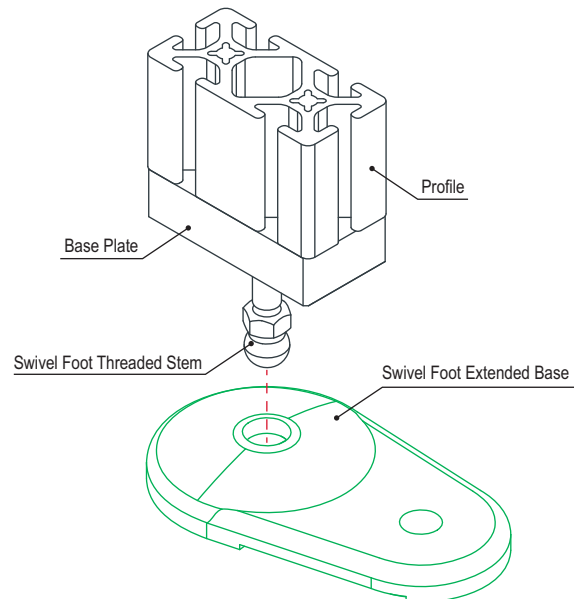

Part Description:

The swivel foot trapezoid base is a heavy-duty leveling foot with a rubber pad that provides resistance to vibration, making it useful for precision applications. It has a powder coat which provides extra durability. The swivel foot trapezoid base requires a threaded stem; see pages 618-619.

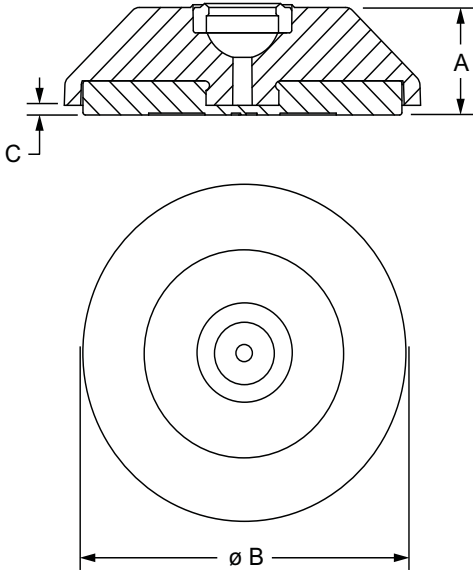

Part No.	Series	Material	Process	Finish	A	B	C	Load Capacity	Weight
12194	F M	Die Cast Zinc	Die-Casting	Black Powder Coated	.866"	2.992"	.079"	6600.00 lb	.480 lb

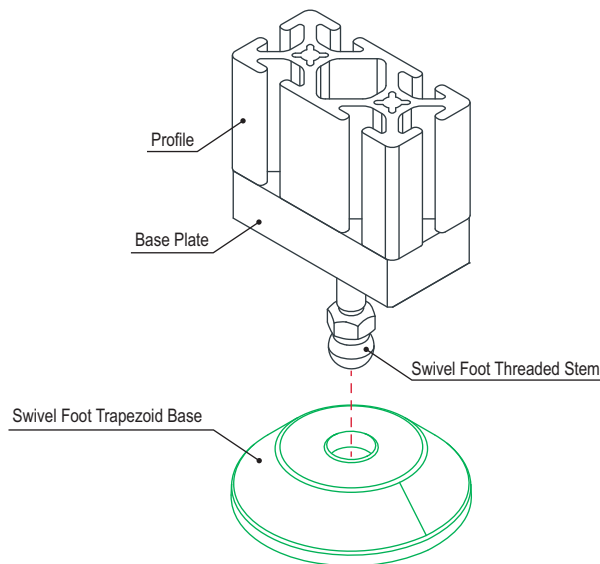

Trapezoid Base Anchor

Part Description:

The trapezoid base anchor is used with the swivel foot trapezoid base (page 621) to securely hold an application in place when used with wedge floor anchors (page 623). It is commonly used when adding to a preexisting build or in instances where the application will need to be moved, for example, when maintenance will be required. It enables repositioning without having to detach the anchor.

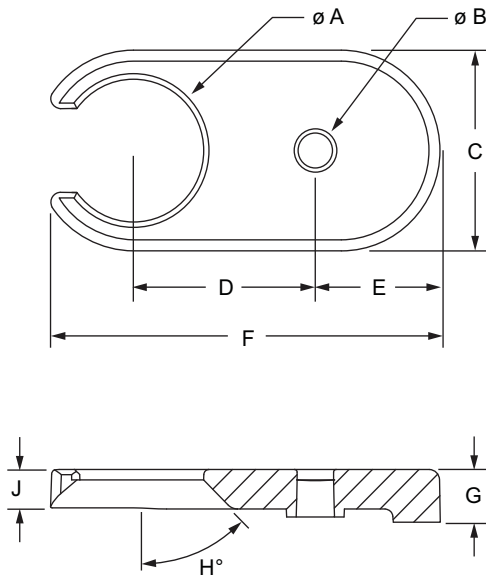

Part No.	Series	A	B	C	D	E	F	G	H	J	Weight
12168	F M	2.126"	.551"	2.992"	2.756"	1.890"	5.905"	.787"	45°	.590"	1.080 lb

Material Specifications

Material	Process	Finish
Die Cast Zinc	Die-Casting	Black Powder Coated

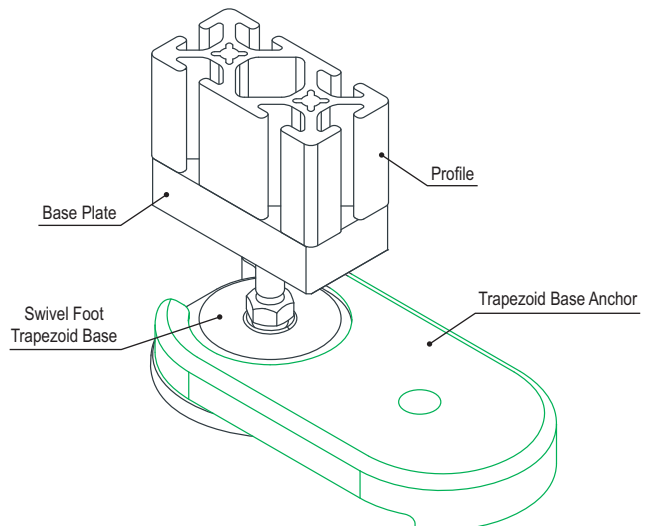

Part Description:

The wedge floor anchor is commonly used with floor to frame options to mount fixtures directly to a solid concrete floor. It's made of high-strength carbon steel for increased durability and longevity and includes a hex nut and washer.

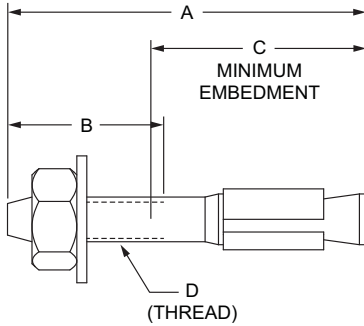

Part No.	Series	Material	Finish	A	B	C	D	Tension	Shear	Weight
2904	F	Steel	Zinc	1.750"	.750"	1.125"	1/4-20	1771.00 lb	1813.00 lb	.033 lb
2905	F			3.250"	2.250"	1.125"	1/4-20	2748.00 lb	2813.00 lb	.049 lb
2901	F			2.750"	1.315"	1.500"	3/8-16	3219.00 lb	4029.00 lb	.095 lb
2902	F			3.750"	2.315"	1.500"	3/8-16	5678.00 lb	4305.00 lb	.121 lb
2903	F			5.000"	3.565"	1.500"	3/8-16	5935.00 lb	4581.00 lb	.153 lb
2906	F			3.750"	1.837"	2.250"	1/2-13	5384.00 lb	6900.00 lb	.229 lb
2907	F			5.500"	3.587"	2.250"	1/2-13	7333.00 lb	7449.00 lb	.307 lb
2908	F			7.000"	5.087"	2.250"	1/2-13	9003.00 lb	7998.00 lb	.371 lb
65-2904	M			44.45mm	19.05mm	28.57mm	1/4-20	803.30 kg	822.35 kg	.0150 kg
65-2905	M			82.55mm	57.15mm	28.57mm	1/4-20	1246.50 kg	1275.95 kg	.0223 kg
65-2901	M			69.85mm	33.40mm	38.10mm	3/8-16	1460.10 kg	1827.50 kg	.0425 kg
65-2902	M			95.25mm	58.80mm	38.10mm	3/8-16	2575.50 kg	1952.70 kg	.0535 kg
65-2903	M			127.00mm	90.55mm	38.10mm	3/8-16	2692.00 kg	2077.90 kg	.0714 kg
65-2906	M			95.25mm	46.67mm	57.16mm	1/2-13	2442.15 kg	3129.80 kg	.1030 kg
65-2907	M	139.70mm	91.10mm	57.16mm	1/2-13	3326.20 kg	3378.80 kg	.1405 kg		
65-2908	M	177.80mm	129.22mm	57.16mm	1/2-13	4083.70 kg	3627.85 kg	.1696 kg		

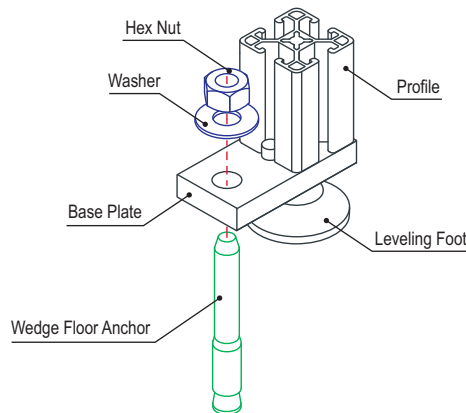

Die-Cast Floor Bracket

Part Description:

The die-cast floor bracket is used with wedge floor anchors (page 623) to secure a fixture directly to a solid concrete floor. It has a black powder-coat finish that helps add durability. The die-cast floor bracket mounts directly to a T-slot profile.

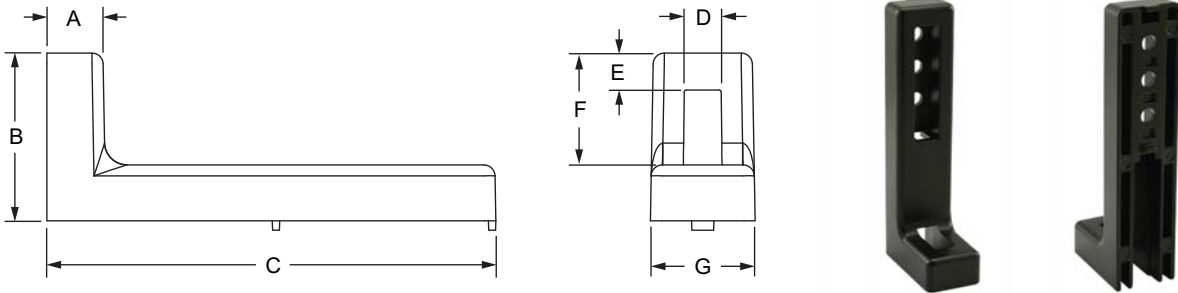

Part No.	Series	Material	Process	Finish	Color	A	B	C	D	E	F	G	Weight
14000	10 25	Die Cast Zinc	Die-Casting	Powder Coated	Black	15.00mm	45.00mm	120.00mm	10.00mm	10.00mm	29.00mm	30.00mm	.1927 kg
14002	15 30 40					15.00mm	45.00mm	120.00mm	10.00mm	10.00mm	29.00mm	30.00mm	.1932 kg
14006	15 40		Formed	Black		20.00mm	60.00mm	160.00mm	10.00mm	10.00mm	25.00mm	38.00mm	.2123 kg
14004	45		Die-Casting	Powder Coated		15.00mm	45.00mm	120.00mm	10.00mm	10.00mm	29.00mm	30.00mm	.1889 kg
14008	45					20.00mm	60.00mm	160.00mm	10.00mm	10.00mm	25.00mm	38.00mm	.4610 kg

Suggested Hardware (Mount to T-Slot)

Part No.	Bolt Assy.	Series	Qty.	Bolt	T-Nut
14000	3486	10	2	1/4-20 x 3/8 SHCS	Economy
14002	3493	15	2	1/4-20 x 5/8 SHCS	Economy
14006	3454	15	2	5/16-18 x 5/8 SHCS	Economy
14000	75-3520	25	2	M6 x 10mm SHCS	Economy
14002	75-3590	30	2	M6 x 10mm SHCS	Drop-In
14002	75-3593	40	2	M6 x 14mm SHCS	Drop-In
14006	75-3625	40	2	M8 x 16mm SHCS	Slide-In
14004	75-3594	45	2	M6 x 14mm SHCS	Drop-In
14008	75-3623	45	2	M8 x 16mm SHCS	Drop-In

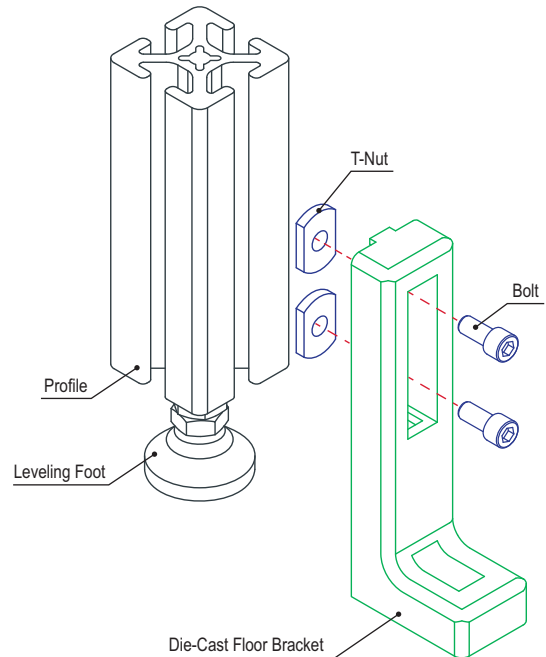

Adjustable Die-Cast Floor Bracket

Part Description:

The adjustable die-cast floor bracket is used with wedge floor anchors (page 623) to secure a fixture directly to a solid concrete floor. It has a black powder-coat finish that helps add durability. The bracket includes a screw and stop plate that enables it to be adjusted up and down without having to lift the entire fixture. The adjustable die-cast floor bracket mounts directly to a T-slot profile.

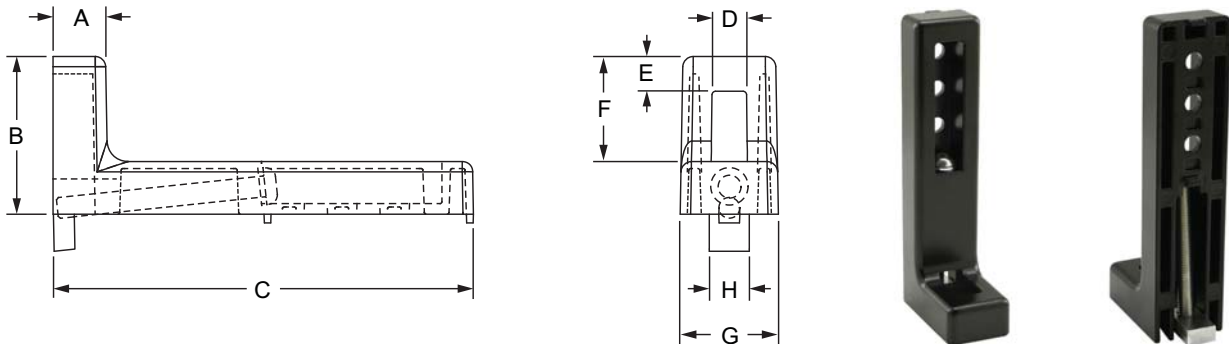

Part No.	Series	A	B	C	D	E	F	G	H	Lifting Height	Weight
14001	10 25	15.00mm	45.00mm	120.00mm	10.00mm	10.00mm	29.00mm	30.00mm	11.50mm	52.00mm	.2141 kg
14003	15 30 40	15.00mm	45.00mm	120.00mm	10.00mm	10.00mm	29.00mm	30.00mm	11.50mm	52.00mm	.2122 kg
14007	15 40	15.00mm	45.00mm	120.00mm	10.00mm	10.00mm	29.00mm	30.00mm	14.90mm	72.00mm	.5175 kg
14005	45	20.00mm	60.00mm	160.00mm	10.00mm	10.00mm	25.00mm	38.00mm	11.50mm	52.00mm	.2155 kg
14009	45	20.00mm	60.00mm	160.00mm	10.00mm	10.00mm	25.00mm	38.00mm	14.90mm	72.00mm	.5224 kg

Material Specifications

Material	Process	Finish	Color
Die Cast Zinc	Die-Casting	Black Powder Coated	Black

Suggested Hardware (Mount to T-Slot)

Part No.	Bolt Assy.	Series	Qty.	Bolt	T-Nut
14001	3486	10	2	1/4-20 x 3/8 SHCS	Economy
14003	3493	15	2	1/4-20 x 5/8 SHCS	Economy
14007	3454	15	2	5/16-18 x 5/8 SHCS	Economy
14001	75-3520	25	2	M6 x 10mm SHCS	Economy
14003	75-3590	30	2	M6 x 10mm SHCS	Drop-In
14003	75-3593	40	2	M6 x 14mm SHCS	Drop-In
14007	75-3625	40	2	M8 x 16mm SHCS	Slide-In
14005	75-3594	45	2	M6 x 14mm SHCS	Drop-In
14009	75-3623	45	2	M8 x 16mm SHCS	Drop-In

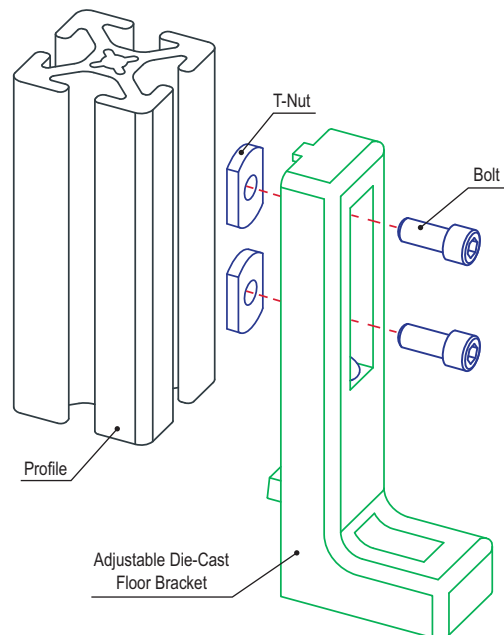

Steel Floor Bracket

Part Description:

The steel floor bracket is zinc-plated and attaches directly to a T-slot profile with the suggested hardware (see chart below). Use wedge anchors (pages 623) to mount the bracket directly to a concrete floor. The design of the steel floor bracket is compact, making it perfect in tight or smaller locations.

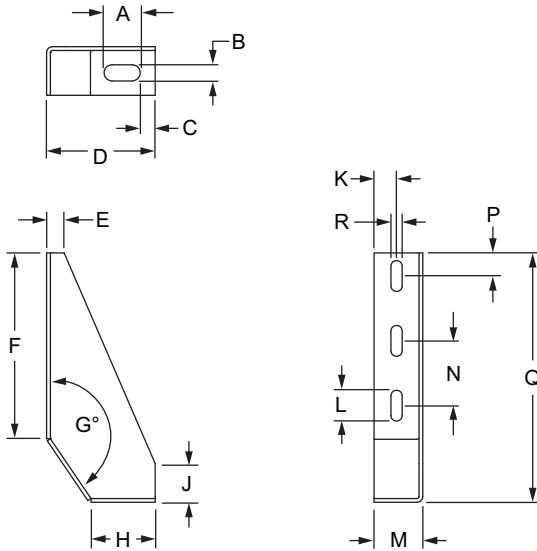

Part No.	Series	A	B	C	D	E	F	G	H	J	K	L	M	N	P	Q	R	Weight
14010	15 40 45	29.00mm	13.00mm	12.00mm	87.00mm	14.00mm	150.00mm	145.78°	53.00mm	31.00mm	19.50mm	25.00mm	39.00mm	52.00mm	18.50mm	200.00mm	9.00mm	.4273 kg

Material Specifications

Material	Process	Finish	Color
Steel	Die-Casting	Zinc	Bright

Suggested Hardware (Mount to T-Slot)

Part No.	Series	Qty.	Bolt	T-Nut
3450	15	3	5/16-18 x 1/2 SHCS	Economy
75-3624	40	3	M8 x 12mm SHCS	Slide-In
75-3623	45	3	M8 x 16mm SHCS	Drop-In

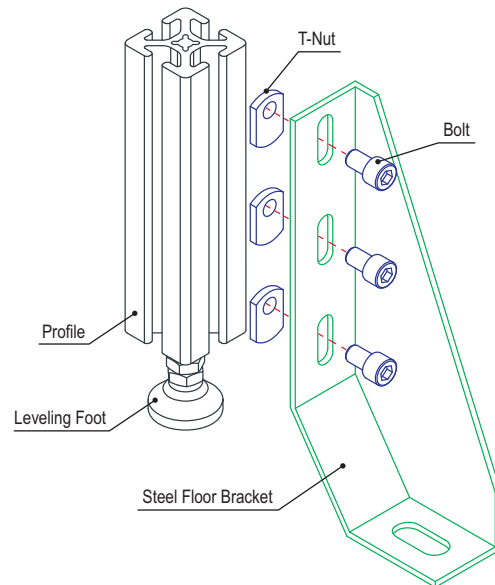

Part Description:

The aluminum floor bracket is a strong, die-cast option that attaches directly to a 45-series profile with the suggested hardware (see chart). The slot tab enables easy alignment. This bracket is commonly used with wedge anchors (page 623) to mount directly to a concrete floor.

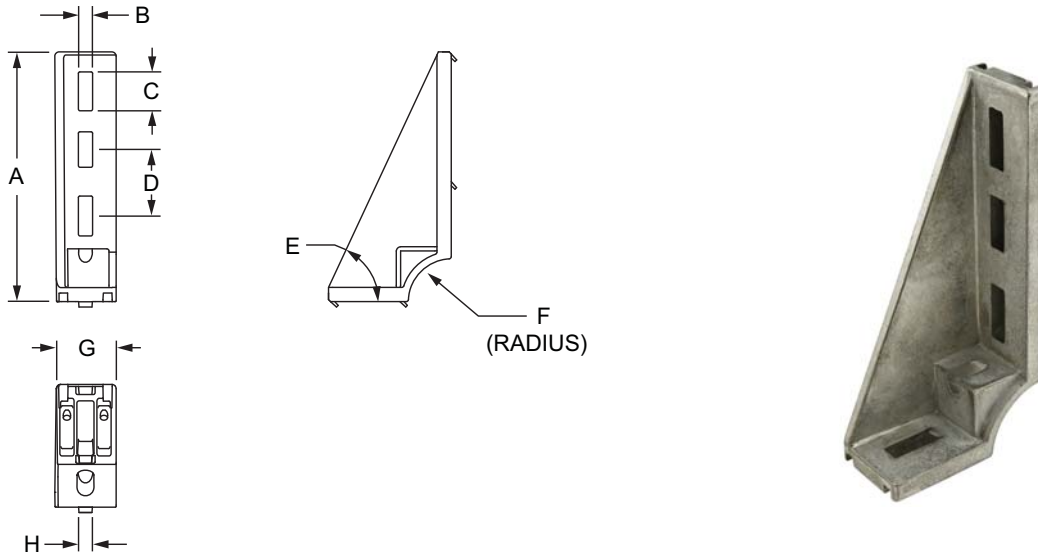

Part No.	Series	A	B	C	D	E	F	G	H	Weight
12028	45	175.00mm	10.00mm	25.00mm	45.00mm	65°	30.00mm	43.00mm	10.00mm	.2600 kg

Material Specifications

Material	Process	Finish
Die Cast Zinc	Die-Casting	Natural

Suggested Hardware (Mount to T-Slot)

Part No.	Series	Qty.	Bolt	T-Nut
75-3630	45	2	M8 x 20mm SHCS	Drop-In

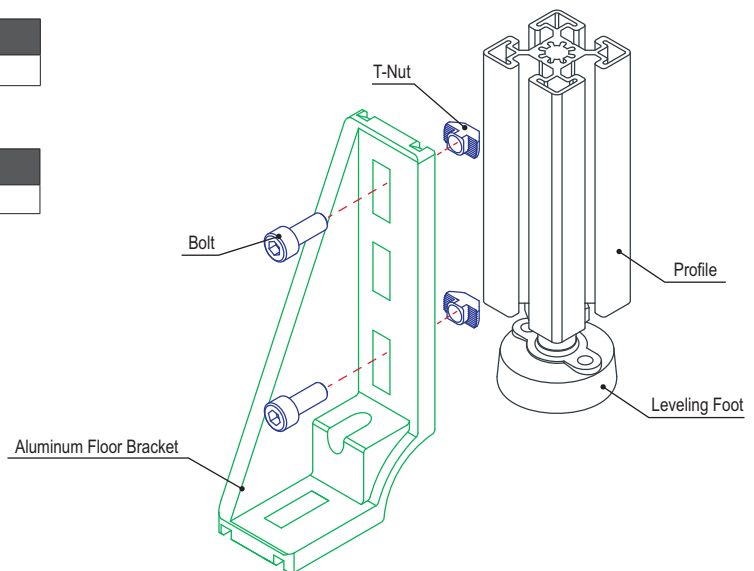

Threaded End Bracket

Part Description:

The threaded end bracket is made of steel and is used to add a leveling foot to a Quick Frame profile.

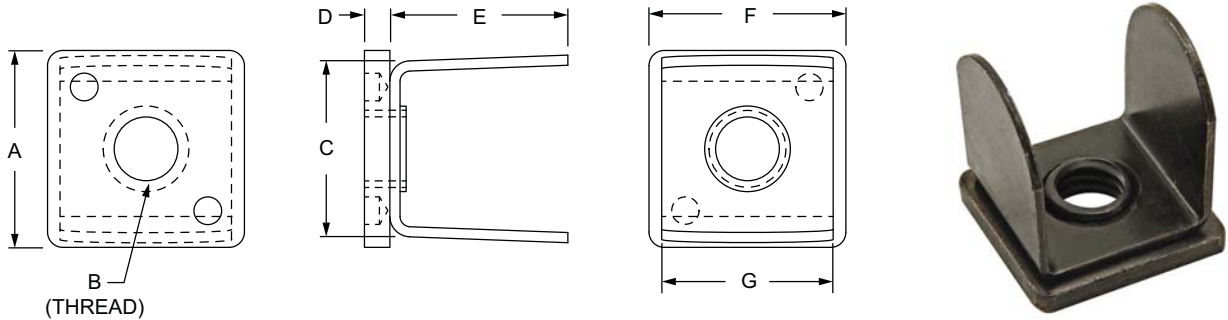

Part No.	Series	A	B	C	D	E	F	G	Weight
9350	QF	.968"	5/16-18	.865"	.125"	.875"	.968"	.843"	.055 lb
9351	QF	.968"	3/8-16	.865"	.125"	.875"	.968"	.843"	.054 lb

Material Specifications

Material	Grade	Process	Finish
Steel	C1010	Stamping	Plain

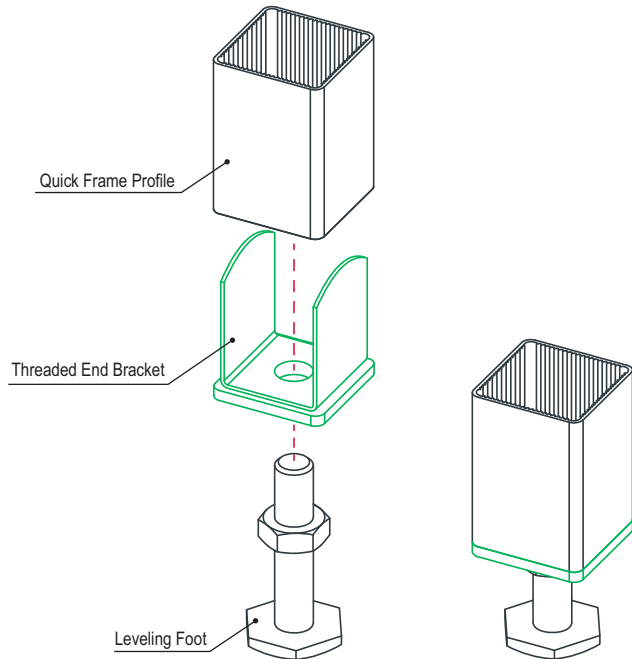



Flange Mount Caster Base Plate

Part Description:

The flange mount caster base plate is made of anodized aluminum to withstand daily use and wear and tear. It bolts to a profile end or side and is commonly used to mount casters for an added layer of strength and durability. It requires a tap (page 853) to mount to the profile end.

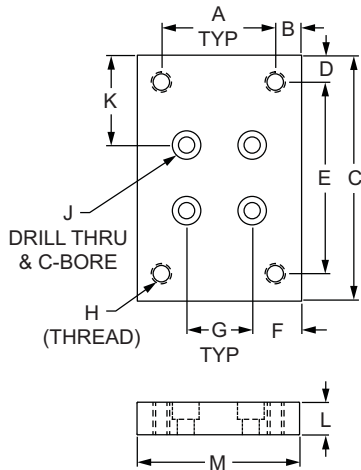

**2418, 2420
25-2418, 40-2420**

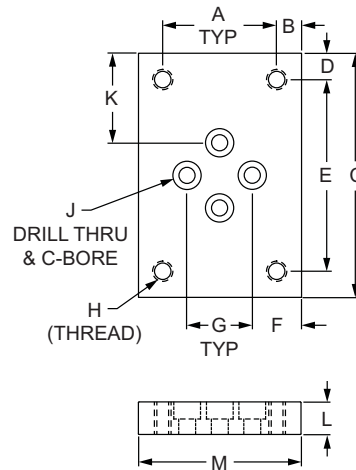

**2419, 2426
25-2419, 40-2426**

Part No.	Series	A	B	C	D	E	F	G	H	J	K	L	M	Weight
2418	10	1.750"	.375"	3.750"	.405"	2.940"	.750"	1.000"	5/16-18	1/4 SHCS	1.375"	.500"	2.500"	.424 lb
2418-Black	10	1.750"	.375"	3.750"	.405"	2.940"	.750"	1.000"	5/16-18	1/4 SHCS	1.375"	.500"	2.500"	.424 lb
2419	10	1.750"	.375"	3.750"	.405"	2.940"	1.375"	1.000"	5/16-18	1/4 SHCS	1.375"	.500"	2.500"	.423 lb
2419-Black	10	1.750"	.375"	3.750"	.405"	2.940"	1.375"	1.000"	5/16-18	1/4 SHCS	1.375"	.500"	2.500"	.423 lb
2426	15	1.750"	.625"	3.750"	.405"	2.940"	.750"	1.500"	5/16-18	5/16 SHCS	1.125"	.750"	3.000"	.765 lb
2426-Black	15	1.750"	.625"	3.750"	.405"	2.940"	.750"	1.500"	5/16-18	5/16 SHCS	1.125"	.750"	3.000"	.765 lb
2420	15	1.750"	.625"	3.750"	.405"	2.940"	.750"	1.500"	5/16-18	5/16 SHCS	1.125"	.750"	3.000"	.762 lb
2420-Black	15	1.750"	.625"	3.750"	.405"	2.940"	.750"	1.500"	5/16-18	5/16 SHCS	1.125"	.750"	3.000"	.762 lb
25-2418	25	44.50mm	9.00mm	95.00mm	10.20mm	74.60mm	18.70mm	25.00mm	M8 x 1.25	M6 SHCS	35.00mm	12.00mm	62.50mm	.1800 kg
25-2418-Black	25	44.50mm	9.00mm	95.00mm	10.20mm	74.60mm	18.70mm	25.00mm	M8 x 1.25	M6 SHCS	35.00mm	12.00mm	62.50mm	.1800 kg
25-2419	25	44.50mm	9.00mm	95.00mm	10.20mm	74.60mm	18.75mm	25.00mm	M8 x 1.25	M6 SHCS	35.00mm	12.00mm	62.50mm	.1800 kg
25-2419-Black	25	44.50mm	9.00mm	95.00mm	10.20mm	74.60mm	18.75mm	25.00mm	M8 x 1.25	M6 SHCS	35.00mm	12.00mm	62.50mm	.1800 kg
40-2426	40	44.40mm	17.80mm	97.00mm	11.20mm	74.60mm	20.00mm	40.00mm	M8 x 1.25	M8 SHCS	28.50mm	19.00mm	80.00mm	.3648 kg
40-2426-Black	40	44.40mm	17.80mm	97.00mm	11.20mm	74.60mm	20.00mm	40.00mm	M8 x 1.25	M8 SHCS	28.50mm	19.00mm	80.00mm	.3648 kg
40-2420	40	44.40mm	17.80mm	97.00mm	11.20mm	74.60mm	20.00mm	40.00mm	M8 x 1.25	M8 SHCS	28.50mm	19.00mm	80.00mm	.3682 kg
40-2420-Black	40	44.40mm	17.80mm	97.00mm	11.20mm	74.60mm	20.00mm	40.00mm	M8 x 1.25	M8 SHCS	28.50mm	19.00mm	80.00mm	.3682 kg

CONTINUE

Flange Mount Caster Base Plate (Continued)

Material Specifications

Part No.	Material	Alloy*	Process	Finish
2418	Aluminum	6105-T5	Milled	Clear Anodize
2418-Black				Black Anodize
2419				Clear Anodize
2419-Black				Black Anodize
2426				Clear Anodize
2426-Black				Black Anodize
2420				Clear Anodize
2420-Black				Black Anodize
25-2418				Clear Anodize
25-2418-Black				Black Anodize
25-2419				Clear Anodize
25-2419-Black				Black Anodize
40-2426				Clear Anodize
40-2426-Black				Black Anodize
40-2420				Clear Anodize
40-2420-Black				Black Anodize

* Or comparable

Required Machining Services

Machining Type	Machined	Reference Page
Tap Profile End	Mount to Profile End	853

Suggested Hardware (Mount to T-Slot)

Part No.	Series	Qty.	Bolt	T-Nut
3491	10	4	1/4-20 x 1/2" SHCS	Economy
3458	15	4	5/16-18 x 7/8" SHCS	Economy
75-3412	25	4	M6 x 12mm SHCS	Economy
75-3430	40	4	M8 x 20mm SHCS	Economy

Suggested Hardware (Mount to Profile End)

Part No.	Series	Qty.	Bolt
3064	10	4	1/4-20 x 3/4" SHCS
3123	15	4	5/16-18 x 1.25" SHCS
13-6516	25	4	M6 x 16mm SHCS (Blue)
13-8525	40	4	M8 x 25mm SHCS (Blue)

Mount to End of Profile

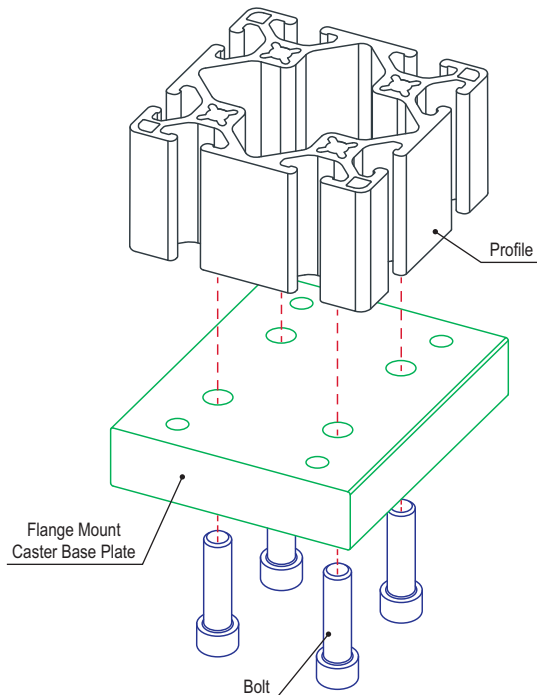

Mount to T-Slot

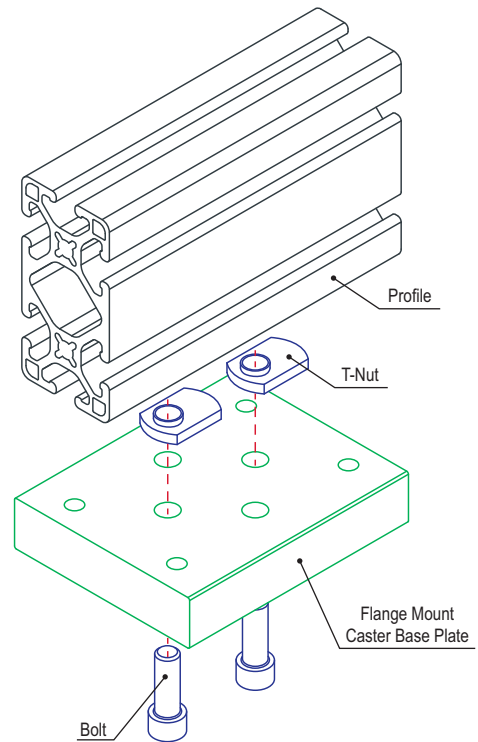



Part Description:

The heavy-duty flange mount caster base plate is made of anodized aluminum to withstand daily use and wear and tear. It bolts to a profile end or side and is commonly used to mount casters with high load capacities for an added layer of strength and durability. The heavy-duty flange mount caster base plate requires a tap (page 853) to mount to the profile end.

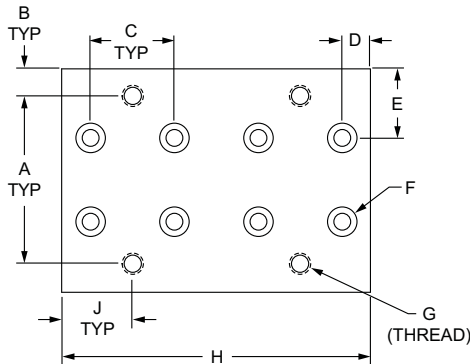

Part No.	Series	A	B	C	D	E	F	G	H	J	K	L	Weight
2147	15	3.000"	.500"	1.500"	.500"	1.250"	5/16 SHCS	3/8-16	5.500"	1.250"	.750"	4.000"	1.493 lb
2147-Black	15	3.000"	.500"	1.500"	.500"	1.250"	5/16 SHCS	3/8-16	5.500"	1.250"	.750"	4.000"	1.493 lb
40-2147	40	76.20mm	11.90mm	40.00mm	13.00mm	30.00mm	M8 SHCS	M10 x 1.5	146.00mm	34.90mm	19.00mm	100.00mm	.6917 kg
40-2147-Black	40	76.20mm	11.90mm	40.00mm	13.00mm	30.00mm	M8 SHCS	M10 x 1.5	146.00mm	34.90mm	19.00mm	100.00mm	.6917 kg

Material Specifications

Part No.	Material	Alloy*	Process	Finish
2147	Aluminum	6105-T5	Milled	Clear Anodize
2147-Black				Black Anodize
40-2147				Clear Anodize
40-2147-Black				Black Anodize

* Or comparable

Required Machining Services

Machining Type	Machined	Reference Page
Tap Profile End	Mount to Profile End	853

Suggested Hardware (Mount to T-Slot)

Part No.	Series	Qty.	Bolt	T-Nut
3458	15	4 TO 8	5/16-18 x 7/8" SHCS	Economy
75-3430	40	4 TO 8	M8 x 20mm SHCS (Blue)	Economy

Suggested Hardware (Mount to Profile End)

Part No.	Series	Qty.	Bolt
3123	15	2 TO 4	5/16-18 x 1.25" SHCS
13-8530	40	2 TO 4	M8 x 30mm SHCS (Blue)

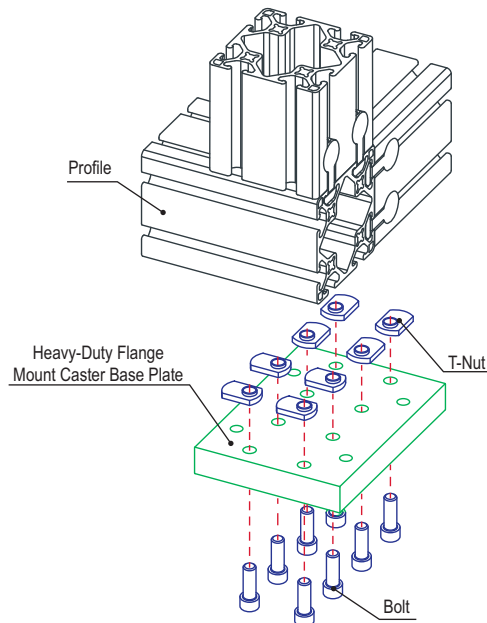

Leveling Caster Base Plate



Part Description:

The leveling caster base plate is made of anodized aluminum to withstand daily use and wear and tear. It bolts to a profile end or side and is commonly used to mount heavy-duty casters for an added layer of strength and durability. It requires a tap (page 853) to mount to the profile end.

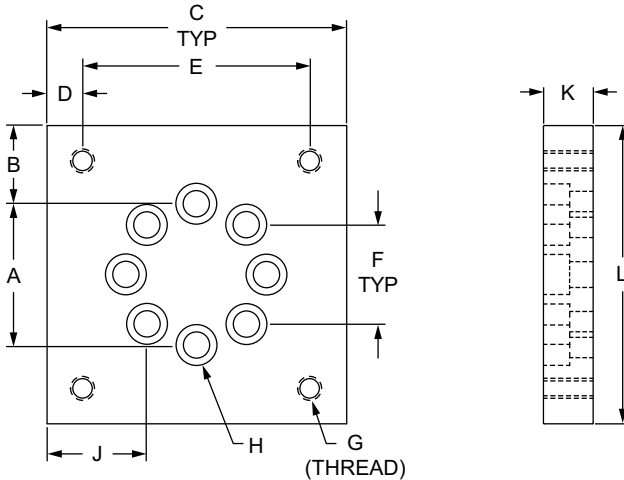

Part No.	Series	A	B	C	D	E	F	G	H	J	K	L	Weight
2406	10	1.414"	.793"	3.000"	.358"	2.284"	1.000"	1/4-20	1/4 SHCS	1.000"	.500"	3.000"	.396 lb
2406-Black	10	1.414"	.793"	3.000"	.358"	2.284"	1.000"	1/4-20	1/4 SHCS	1.000"	.500"	3.000"	.396 lb
2407	15	2.122"	.439"	3.000"	.358"	2.284"	1.500"	1/4-20	5/16 SHCS	.750"	.750"	3.000"	.567 lb
2407-Black	15	2.122"	.439"	3.000"	.358"	2.284"	1.500"	1/4-20	5/16 SHCS	.750"	.750"	3.000"	.567 lb
2408	15	2.122"	.689"	3.500"	.372"	2.756"	1.500"	5/16-18	5/16 SHCS	1.000"	.750"	3.500"	.793 lb
2408-Black	15	2.122"	.689"	3.500"	.372"	2.756"	1.500"	5/16-18	5/16 SHCS	1.000"	.750"	3.500"	.793 lb
2409	15	2.122"	.939"	4.000"	.622"	2.756"	1.500"	3/8-16	5/16 SHCS	1.250"	.750"	4.000"	1.057 lb
2409-Black	15	2.122"	.939"	4.000"	.622"	2.756"	1.500"	3/8-16	5/16 SHCS	1.250"	.750"	4.000"	1.057 lb
25-2406	25	35.36mm	20.42mm	76.20mm	9.09mm	58.02mm	25.00mm	M6 x 1.0	M6 SHCS	25.60mm	12.70mm	76.20mm	.1800 kg
25-2406-Black	25	35.36mm	20.42mm	76.20mm	9.09mm	58.02mm	25.00mm	M6 x 1.0	M6 SHCS	25.60mm	12.70mm	76.20mm	.1800 kg
40-2407	40	58.02mm	9.82mm	76.20mm	9.09mm	58.02mm	40.00mm	M6 x 1.0	M8 SHCS	18.10mm	19.05mm	76.20mm	.2558 kg
40-2407-Black	40	58.02mm	9.82mm	76.20mm	9.09mm	58.02mm	40.00mm	M6 x 1.0	M8 SHCS	18.10mm	19.05mm	76.20mm	.2558 kg
40-2408	40	56.56mm	16.17mm	88.90mm	9.45mm	70.00mm	40.00mm	M8 x 1.25	M8 SHCS	24.45mm	19.05mm	88.90mm	.3574 kg
40-2408-Black	40	56.56mm	16.17mm	88.90mm	9.45mm	70.00mm	40.00mm	M8 x 1.25	M8 SHCS	24.45mm	19.05mm	88.90mm	.3574 kg
40-2409	40	56.56mm	22.52mm	101.60mm	15.80mm	70.00mm	40.00mm	M10 x 1.50	M8 SHCS	30.80mm	19.05mm	101.60mm	.4779 kg
40-2409-Black	40	56.56mm	22.52mm	101.60mm	15.80mm	70.00mm	40.00mm	M10 x 1.50	M8 SHCS	30.80mm	19.05mm	101.60mm	.4779 kg

FLOOR TO FRAME

CONTINUE

Leveling Caster Base Plate (Continued)

Material Specifications

Part No.	Material	Alloy*	Process	Finish
2406	Aluminum	6105-T5	Milled	Clear Anodize
2406-Black				Black Anodize
2407				Clear Anodize
2407-Black				Black Anodize
2408				Clear Anodize
2408-Black				Black Anodize
2409				Clear Anodize
2409-Black				Black Anodize
25-2406				Clear Anodize
25-2406-Black				Black Anodize
40-2407				Clear Anodize
40-2407-Black				Black Anodize
40-2408				Clear Anodize
40-2408-Black				Black Anodize
40-2409				Clear Anodize
40-2409-Black				Black Anodize

* Or comparable

Required Machining Services

Machining Type	Machined	Reference Page
Tap Profile End	Mount to Profile End	853

Suggested Hardware (Mount to T-Slot)

Part No.	Series	Qty.	Bolt	T-Nut
3491	10	4	1/4-20 x 1/2" SHCS	Economy
3458	15	4	5/16-18 x 7/8" SHCS	Economy
75-3412	25	4	M6 x 12mm SHCS	Economy
75-3430	40	4	M8 x 20mm SHCS	Economy

Suggested Hardware (Mount to Profile End)

Part No.	Series	Qty.	Bolt
3064	10	4	1/4-20 x 3/4" SHCS
3123	15	4	5/16-18 x 1.25" SHCS
13-6516	25	4	M6 x 16mm SHCS (Blue)
13-8525	40	4	M8 x 25mm SHCS (Blue)

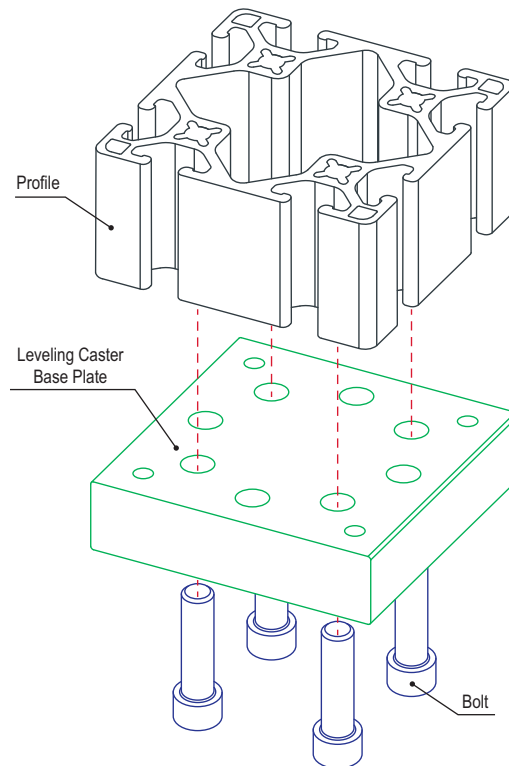

Position Floor Lock Base Plate

Part Description:

The position floor lock base plate is made of anodized aluminum to withstand daily use and wear and tear. It bolts to a profile end or side and is commonly used to mount position floor locks for an added layer of strength and durability. It requires a tap (page 853) to mount to a profile end.

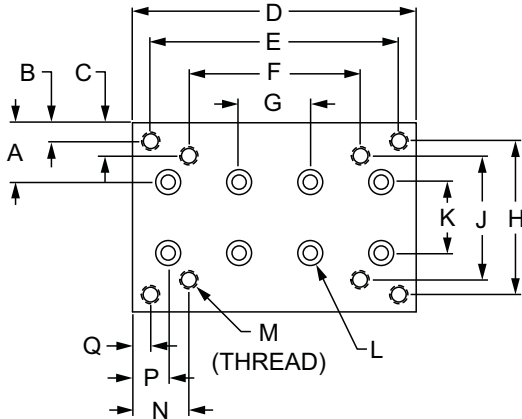

Part No.	Series	A	B	C	D	E	F	G	H	J
2148	15	1.250"	.375"	.688"	6.000"	5.250"	3.624"	1.500"	3.250"	2.624"
2148-Black	15	1.250"	.375"	.688"	6.000"	5.250"	3.624"	1.500"	3.250"	2.624"
40-2148	40	30.00mm	8.73mm	16.68mm	158.00mm	133.34mm	92.00mm	40.00mm	82.54mm	66.64mm
40-2148-Black	40	30.00mm	8.73mm	16.68mm	158.00mm	133.34mm	92.00mm	40.00mm	82.54mm	66.64mm
		K	L	M	N	P	Q	R	S	Weight
2148	15	1.500"	5/16 SHCS	3/8-16	1.188"	.750"	.375"	.750"	4.000"	1.595 lb
2148-Black	15	1.500"	5/16 SHCS	3/8-16	1.188"	.750"	.375"	.750"	4.000"	1.595 lb
40-2148	40	40.00mm	M8 SHCS	M10 x 1.50	33.00mm	19.00mm	12.33mm	19.00mm	100.00mm	.7407 kg
40-2148-Black	40	40.00mm	M8 SHCS	M10 x 1.50	33.00mm	19.00mm	12.33mm	19.00mm	100.00mm	.7407 kg

FLOOR TO FRAME

CONTINUE



Position Floor Lock Base Plate (Continued)

Material Specifications

Part No.	Material	Alloy*	Process	Finish
2148	Aluminum	6105-T5	Milled	Clear Anodize
2148-Black				Black Anodize
40-2148				Clear Anodize
40-2148-Black				Black Anodize

* Or comparable

Required Machining Services

Machining Type	Machined	Reference Page
Tap Profile End	Mounting Profile	853

Suggested Hardware (Mount to T-Slot)

Part No.	Series	Qty.	Bolt	T-Nut
3458	15	4 TO 8	5/16-18 x 7/8" SHCS	Economy
75-3430	40	4 TO 8	M8 x 20mm SHCS	Economy

Suggested Hardware (Mount to Profile End)

Part No.	Series	Qty.	Bolt
3123	15	4 TO 8	5/16-18 x 1.25" SHCS
13-8530	40	4 TO 8	M8 x 30mm SHCS (Blue)

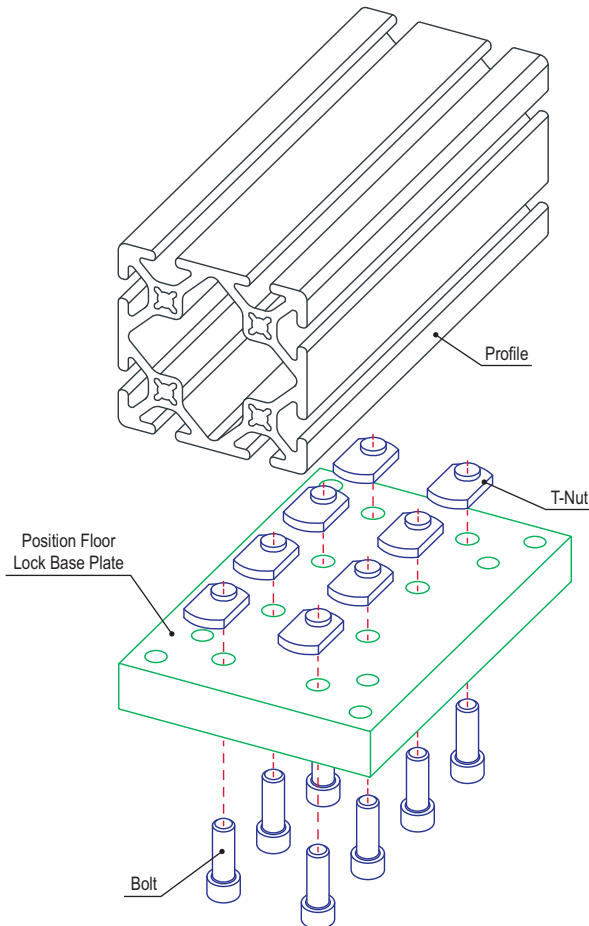

3 Hole - Center Tap Base Plate

80/20[®] Inc.

Part Description:

The 3 hole – center tap base plate is made of anodized aluminum to withstand daily use and wear and tear. It mounts leveling feet and threaded stem casters, and is commonly used on a rectangular profile end to center mount the foot or caster. The 3 hole – center tap base plate can also be used on a profile side. It requires a tap (page 853) to mount to a profile end.

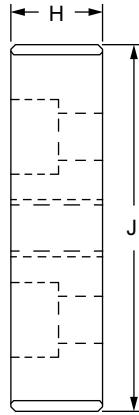
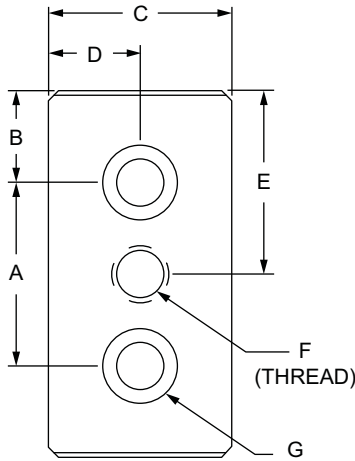

Part No.	Series	Color	A	B	C	D	E	F	G	H	J	Weight
2124	10	Clear	1.000"	.500"	1.000"	.500"	1.000"	5/16-18	1/4 SHCS	.500"	2.000"	.084 lb
2124-Black	10	Black	1.000"	.500"	1.000"	.500"	1.000"	5/16-18	1/4 SHCS	.500"	2.000"	.084 lb
2128	10	Clear	1.000"	.500"	1.000"	.500"	1.000"	1/4-20	1/4 SHCS	.500"	2.000"	.086 lb
2128-Black	10	Black	1.000"	.500"	1.000"	.500"	1.000"	1/4-20	1/4 SHCS	.500"	2.000"	.086 lb
2129	10	Clear	1.000"	.500"	1.000"	.500"	1.000"	3/8-16	1/4 SHCS	.500"	2.000"	.083 lb
2129-Black	10	Black	1.000"	.500"	1.000"	.500"	1.000"	3/8-16	1/4 SHCS	.500"	2.000"	.083 lb
2137	10	Clear	1.000"	.500"	1.000"	.500"	1.000"	7/16-14	1/4 SHCS	.500"	2.000"	.082 lb
2137-Black	10	Black	1.000"	.500"	1.000"	.500"	1.000"	7/16-14	1/4 SHCS	.500"	2.000"	.082 lb
2361	10	Clear	1.000"	.500"	1.000"	.500"	1.000"	1/2-13	1/4 SHCS	.500"	2.000"	.079 lb
2361-Black	10	Black	1.000"	.500"	1.000"	.500"	1.000"	1/2-13	1/4 SHCS	.500"	2.000"	.079 lb
2130	15	Clear	1.500"	.750"	1.500"	.750"	1.500"	3/8-16	5/16 SHCS	.750"	3.000"	.298 lb
2130-Black	15	Black	1.500"	.750"	1.500"	.750"	1.500"	3/8-16	5/16 SHCS	.750"	3.000"	.298 lb
2135	15	Clear	1.500"	.750"	1.500"	.750"	1.500"	1/2-13	5/16 SHCS	.750"	3.000"	.294 lb
2135-Black	15	Black	1.500"	.750"	1.500"	.750"	1.500"	1/2-13	5/16 SHCS	.750"	3.000"	.294 lb
2138	15	Clear	1.500"	.750"	1.500"	.750"	1.500"	7/16-14	5/16 SHCS	.750"	3.000"	.297 lb
2138-Black	15	Black	1.500"	.750"	1.500"	.750"	1.500"	7/16-14	5/16 SHCS	.750"	3.000"	.297 lb
2365	15	Clear	1.500"	.750"	1.500"	.750"	1.500"	3/4-10	5/16 SHCS	.750"	3.000"	.277 lb
2365-Black	15	Black	1.500"	.750"	1.500"	.750"	1.500"	3/4-10	5/16 SHCS	.750"	3.000"	.277 lb

FLOOR TO FRAME

CONTINUE



Part No.	Series	Color	A	B	C	D	E	F	G	H	J	Weight
25-2128	25	Clear	25.00mm	12.50mm	25.00mm	12.50mm	25.00mm	M6 x 1.0	M6 SHCS	12.00mm	50.00mm	.0358 kg
25-2128-Black	25	Black	25.00mm	12.50mm	25.00mm	12.50mm	25.00mm	M6 x 1.0	M6 SHCS	12.00mm	50.00mm	.0358 kg
25-2129	25	Clear	25.00mm	12.50mm	25.00mm	12.50mm	25.00mm	M8 x 1.25	M6 SHCS	12.00mm	50.00mm	.0347 kg
25-2129-Black	25	Black	25.00mm	12.50mm	25.00mm	12.50mm	25.00mm	M8 x 1.25	M6 SHCS	12.00mm	50.00mm	.0347 kg
25-2137	25	Clear	25.00mm	12.50mm	25.00mm	12.50mm	25.00mm	M10 x 1.50	M6 SHCS	12.00mm	50.00mm	.0340 kg
25-2137-Black	25	Black	25.00mm	12.50mm	25.00mm	12.50mm	25.00mm	M10 x 1.50	M6 SHCS	12.00mm	50.00mm	.0340 kg
25-2361	25	Clear	25.00mm	12.50mm	25.00mm	12.50mm	25.00mm	M12 x 1.75	M6 SHCS	12.00mm	50.00mm	.0327 kg
25-2361-Black	25	Black	25.00mm	12.50mm	25.00mm	12.50mm	25.00mm	M12 x 1.75	M6 SHCS	12.00mm	50.00mm	.0327 kg
40-2130	40	Clear	40.00mm	20.00mm	40.00mm	20.00mm	40.00mm	M10 x 1.50	M8 SHCS	19.00mm	80.00mm	.1485 kg
40-2130-Black	40	Black	40.00mm	20.00mm	40.00mm	20.00mm	40.00mm	M10 x 1.50	M8 SHCS	19.00mm	80.00mm	.1485 kg
40-2135	40	Clear	40.00mm	20.00mm	40.00mm	20.00mm	40.00mm	M12 x 1.75	M8 SHCS	19.00mm	80.00mm	.1471 kg
40-2135-Black	40	Black	40.00mm	20.00mm	40.00mm	20.00mm	40.00mm	M12 x 1.75	M8 SHCS	19.00mm	80.00mm	.1471 kg
40-2138	40	Clear	40.00mm	20.00mm	40.00mm	20.00mm	40.00mm	M16 x 2.0	M8 SHCS	19.00mm	80.00mm	.1433 kg
40-2138-Black	40	Black	40.00mm	20.00mm	40.00mm	20.00mm	40.00mm	M16 x 2.0	M8 SHCS	19.00mm	80.00mm	.1433 kg
40-2365	40	Clear	40.00mm	20.00mm	40.00mm	20.00mm	40.00mm	M20 x 2.5	M8 SHCS	19.00mm	80.00mm	.1380 kg
40-2365-Black	40	Black	40.00mm	20.00mm	40.00mm	20.00mm	40.00mm	M20 x 2.5	M8 SHCS	19.00mm	80.00mm	.1380 kg

Material Specifications

Material	Alloy*	Process	Finish
Aluminum	6105-T5	Milled	Anodize

* Or comparable

Required Machining Services

Machining Type	Machined	Reference Page
Tap Profile End	Mount to Profile End	853

Suggested Hardware (Mount to T-Slot)

Part No.	Series	Qty.	Bolt	T-Nut
3491	10	2	1/4-20 x 1/2" SHCS	Economy
3458	15	2	5/16-18 x 7/8" SHCS	Economy
75-3412	25	2	M6 x 12mm SHCS	Economy
75-3430	40	2	M8 x 20mm SHCS	Economy

Suggested Hardware (Mount to Profile End)

Part No.	Series	Qty.	Bolt
3064	10	2	1/4-20 x 3/4" SHCS
3123	15	2	5/16-18 x 1.25" SHCS
13-6516	25	2	M6 x 16mm SHCS (Blue)
13-8525	40	2	M8 x 25mm SHCS (Blue)

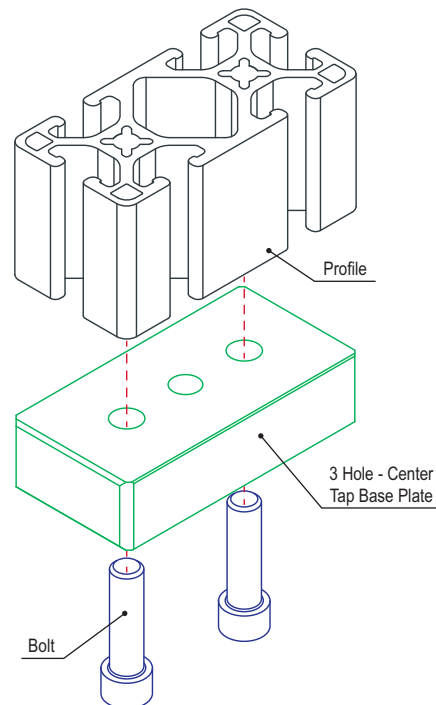

5 Hole - Center Tap Base Plate

Part Description:

The 5 hole – center tap base plate is made of anodized aluminum to withstand daily use and wear and tear. It mounts leveling feet and threaded stem casters, and is commonly used on profiles to center mount a foot or caster. The 5 hole – center tap base plate can also be used on a profile side. It requires a tap (page 853) to mount to a profile end.

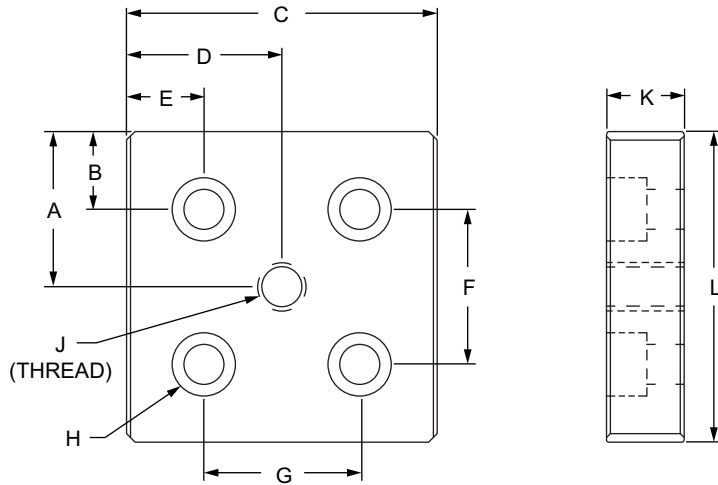

Part No.	Series	Color	A	B	C	D	E	F	G	H	J	K	L	Weight
2127	10	Clear	1.000"	.500"	2.000"	1.000"	.500"	1.000"	1.000"	1/4 SHCS	5/16-18	.500"	2.000"	.172 lb
2127-Black	10	Black	1.000"	.500"	2.000"	1.000"	.500"	1.000"	1.000"	1/4 SHCS	5/16-18	.500"	2.000"	.172 lb
2131	10	Clear	1.000"	.500"	2.000"	1.000"	.500"	1.000"	1.000"	1/4 SHCS	3/8-16	.500"	2.000"	.169 lb
2131-Black	10	Black	1.000"	.500"	2.000"	1.000"	.500"	1.000"	1.000"	1/4 SHCS	3/8-16	.500"	2.000"	.169 lb
2132	10	Clear	1.000"	.500"	2.000"	1.000"	.500"	1.000"	1.000"	1/4 SHCS	1/2-13	.500"	2.000"	.166 lb
2132-Black	10	Black	1.000"	.500"	2.000"	1.000"	.500"	1.000"	1.000"	1/4 SHCS	1/2-13	.500"	2.000"	.166 lb
2139	10	Clear	1.000"	.500"	2.000"	1.000"	.500"	1.000"	1.000"	1/4 SHCS	7/16-14	.500"	2.000"	.168 lb
2139-Black	10	Black	1.000"	.500"	2.000"	1.000"	.500"	1.000"	1.000"	1/4 SHCS	7/16-14	.500"	2.000"	.168 lb
2362	10	Clear	1.000"	.500"	2.000"	1.000"	.500"	1.000"	1.000"	1/4 SHCS	3/4-10	.500"	2.000"	.156 lb
2362-Black	10	Black	1.000"	.500"	2.000"	1.000"	.500"	1.000"	1.000"	1/4 SHCS	3/4-10	.500"	2.000"	.156 lb
2140	15	Clear	1.500"	.750"	3.000"	1.500"	.750"	1.500"	1.500"	5/16 SHCS	1/2-13	.750"	3.000"	.604 lb
2140-Black	15	Black	1.500"	.750"	3.000"	1.500"	.750"	1.500"	1.500"	5/16 SHCS	1/2-13	.750"	3.000"	.604 lb
2145	15	Clear	1.500"	.750"	3.000"	1.500"	.750"	1.500"	1.500"	5/16 SHCS	7/16-14	.750"	3.000"	.607 lb
2145-Black	15	Black	1.500"	.750"	3.000"	1.500"	.750"	1.500"	1.500"	5/16 SHCS	7/16-14	.750"	3.000"	.607 lb
2366	15	Clear	1.500"	.750"	3.000"	1.500"	.750"	1.500"	1.500"	5/16 SHCS	3/4-10	.750"	3.000"	.588 lb
2366-Black	15	Black	1.500"	.750"	3.000"	1.500"	.750"	1.500"	1.500"	5/16 SHCS	3/4-10	.750"	3.000"	.588 lb

CONTINUE



5 Hole - Center Tap Base Plate (Continued)

Part No.	Series	Color	A	B	C	D	E	F	G	H	J	K	L	Weight
25-2131	25	Clear	25.00mm	12.50mm	50.00mm	25.00mm	12.50mm	25.00mm	25.00mm	M6 SHCS	M10 x 1.50	12.00mm	50.00mm	.0700 kg
25-2131-Black	25	Black	25.00mm	12.50mm	50.00mm	25.00mm	12.50mm	25.00mm	25.00mm	M6 SHCS	M10 x 1.50	12.00mm	50.00mm	.0700 kg
25-2132	25	Clear	25.00mm	12.50mm	50.00mm	25.00mm	12.50mm	25.00mm	25.00mm	M6 SHCS	M16 x 2.0	12.00mm	50.00mm	.0700 kg
25-2132-Black	25	Black	25.00mm	12.50mm	50.00mm	25.00mm	12.50mm	25.00mm	25.00mm	M6 SHCS	M16 x 2.0	12.00mm	50.00mm	.0700 kg
25-2139	25	Clear	25.00mm	12.50mm	50.00mm	25.00mm	12.50mm	25.00mm	25.00mm	M6 SHCS	M12 x 1.75	12.00mm	50.00mm	.0689 kg
25-2139-Black	25	Black	25.00mm	12.50mm	50.00mm	25.00mm	12.50mm	25.00mm	25.00mm	M6 SHCS	M12 x 1.75	12.00mm	50.00mm	.0689 kg
25-2362	25	Clear	25.00mm	12.50mm	50.00mm	25.00mm	12.50mm	25.00mm	25.00mm	M6 SHCS	M20 x 2.5	12.00mm	50.00mm	.0630 kg
25-2362-Black	25	Black	25.00mm	12.50mm	50.00mm	25.00mm	12.50mm	25.00mm	25.00mm	M6 SHCS	M20 x 2.5	12.00mm	50.00mm	.0630 kg
40-2140	40	Clear	40.00mm	20.00mm	80.00mm	40.00mm	20.00mm	40.00mm	40.00mm	M8 SHCS	M12 x 1.75	19.00mm	80.00mm	.3002 kg
40-2140-Black	40	Black	40.00mm	20.00mm	80.00mm	40.00mm	20.00mm	40.00mm	40.00mm	M8 SHCS	M12 x 1.75	19.00mm	80.00mm	.3002 kg
40-2145	40	Clear	40.00mm	20.00mm	80.00mm	40.00mm	20.00mm	40.00mm	40.00mm	M8 SHCS	M16 x 2.0	19.00mm	80.00mm	.2950 kg
40-2145-Black	40	Black	40.00mm	20.00mm	80.00mm	40.00mm	20.00mm	40.00mm	40.00mm	M8 SHCS	M16 x 2.0	19.00mm	80.00mm	.2950 kg
40-2366	40	Clear	40.00mm	20.00mm	80.00mm	40.00mm	20.00mm	40.00mm	40.00mm	M8 SHCS	M20 x 2.5	19.00mm	80.00mm	.2921 kg
40-2366-Black	40	Black	40.00mm	20.00mm	80.00mm	40.00mm	20.00mm	40.00mm	40.00mm	M8 SHCS	M20 x 2.5	19.00mm	80.00mm	.2921 kg

Material Specifications

Material	Alloy*	Process	Finish
Aluminum	6105-T5	Milled	Anodize

* Or comparable

Required Machining Services

Machining Type	Machined	Reference Page
Tap Profile End	Mounting Profile	853

Suggested Hardware (Mount to T-Slot)

Part No.	Series	Qty.	Bolt	T-Nut
3491	10	4	1/4-20 x 1/2" SHCS	Economy
3458	15	4	5/16-18 x 7/8" SHCS	Economy
75-3412	25	4	M6 x 12mm SHCS	Economy
75-3430	40	4	M8 x 20mm SHCS	Economy

Suggested Hardware (Mount to Profile End)

Part No.	Series	Qty.	Bolt
3064	10	4	1/4-20 x 3/4" SHCS
3123	15	4	5/16-18 x 1.25" SHCS
13-6516	25	4	M6 x 16mm SHCS (Blue)
13-8525	40	4	M8 x 25mm SHCS (Blue)

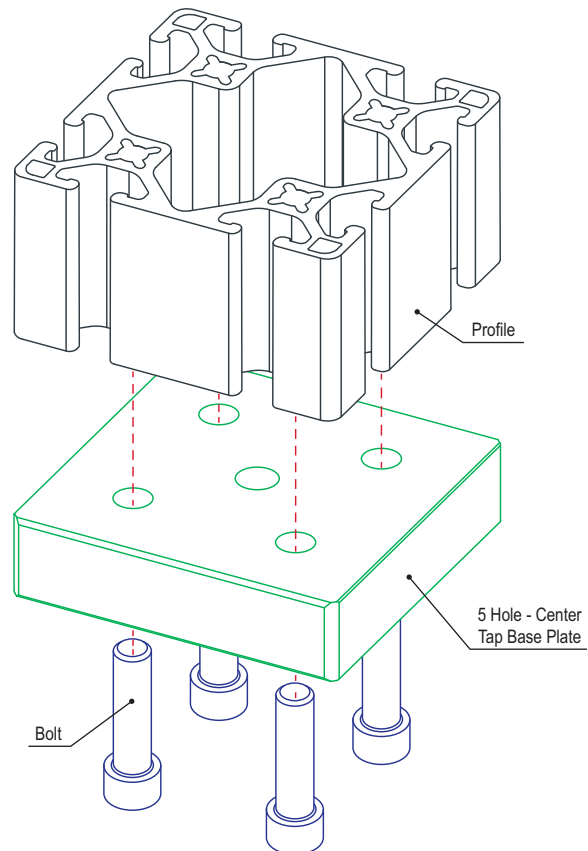

4 Hole - Offset Tap Base Plate

Part Description:

The 4 hole – offset tap base plate is made of anodized aluminum to withstand daily use and wear and tear. It mounts leveling feet and threaded stem casters to a profile end or side for an added layer of strength and durability. The offset provides clearance for the threaded stem providing a greater clearance area. It requires a tap (page 853) to mount to a profile end.

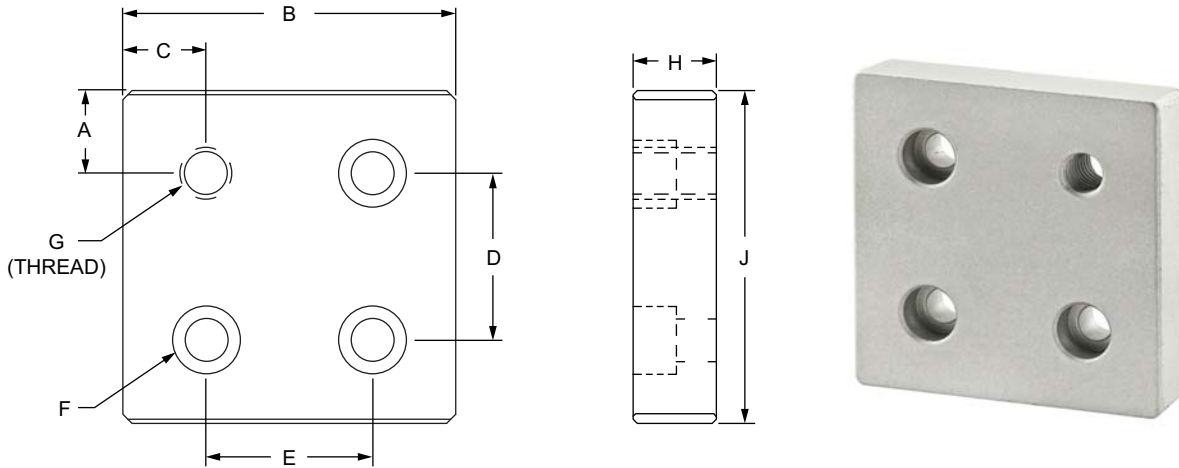

Part No.	Series	Color	A	B	C	D	E	F	G	H	J	Weight
2136	10	Clear	.500"	2.000"	.500"	1.000"	1.000"	1/4 SHCS	5/16-18	.500"	2.000"	.176 lb
2136-Black	10	Black	.500"	2.000"	.500"	1.000"	1.000"	1/4 SHCS	5/16-18	.500"	2.000"	.176 lb
2142	10	Clear	.500"	2.000"	.500"	1.000"	1.000"	1/4 SHCS	3/8-16	.500"	2.000"	.175 lb
2142-Black	10	Black	.500"	2.000"	.500"	1.000"	1.000"	1/4 SHCS	3/8-16	.500"	2.000"	.175 lb
2143	10	Clear	.500"	2.000"	.500"	1.000"	1.000"	1/4 SHCS	7/16-14	.500"	2.000"	.173 lb
2143-Black	10	Black	.500"	2.000"	.500"	1.000"	1.000"	1/4 SHCS	7/16-14	.500"	2.000"	.173 lb
2363	10	Clear	.500"	2.000"	.500"	1.000"	1.000"	1/4 SHCS	1/2-13	.500"	2.000"	.171 lb
2363-Black	10	Black	.500"	2.000"	.500"	1.000"	1.000"	1/4 SHCS	1/2-13	.500"	2.000"	.171 lb
2364	10	Clear	.500"	2.000"	.500"	1.000"	1.000"	1/4 SHCS	3/4-10	.500"	2.000"	.160 lb
2364-Black	10	Black	.500"	2.000"	.500"	1.000"	1.000"	1/4 SHCS	3/4-10	.500"	2.000"	.160 lb
2141	15	Clear	.750"	3.000"	.750"	1.500"	1.500"	5/16 SHCS	1/2-13	.750"	3.000"	.616 lb
2141-Black	15	Black	.750"	3.000"	.750"	1.500"	1.500"	5/16 SHCS	1/2-13	.750"	3.000"	.616 lb
2146	15	Clear	.750"	3.000"	.750"	1.500"	1.500"	5/16 SHCS	7/16-14	.750"	3.000"	.618 lb
2146-Black	15	Black	.750"	3.000"	.750"	1.500"	1.500"	5/16 SHCS	7/16-14	.750"	3.000"	.618 lb
2367	15	Clear	.750"	3.000"	.750"	1.500"	1.500"	5/16 SHCS	3/4-10	.750"	3.000"	.599 lb
2367-Black	15	Black	.750"	3.000"	.750"	1.500"	1.500"	5/16 SHCS	3/4-10	.750"	3.000"	.599 lb



4 Hole - Offset Tap Base Plate (Continued)

Part No.	Series	Color	A	B	C	D	E	F	G	H	J	Weight
25-2142	25	Clear	12.50mm	50.00mm	12.50mm	25.00mm	25.00mm	M6 SHCS	M10 x 1.50	12.00mm	50.00mm	.0717 kg
25-2142-Black	25	Black	12.50mm	50.00mm	12.50mm	25.00mm	25.00mm	M6 SHCS	M10 x 1.50	12.00mm	50.00mm	.0717 kg
25-2143	25	Clear	12.50mm	50.00mm	12.50mm	25.00mm	25.00mm	M6 SHCS	M12 x 1.75	12.00mm	50.00mm	.0712 kg
25-2143-Black	25	Black	12.50mm	50.00mm	12.50mm	25.00mm	25.00mm	M6 SHCS	M12 x 1.75	12.00mm	50.00mm	.0712 kg
25-2363	25	Clear	12.50mm	50.00mm	12.50mm	25.00mm	25.00mm	M6 SHCS	M16 x 2.0	12.00mm	50.00mm	.0689 kg
25-2363-Black	25	Black	12.50mm	50.00mm	12.50mm	25.00mm	25.00mm	M6 SHCS	M16 x 2.0	12.00mm	50.00mm	.0689 kg
25-2364	25	Clear	12.50mm	50.00mm	12.50mm	25.00mm	25.00mm	M6 SHCS	M20 x 2.5	12.00mm	50.00mm	.0649 kg
25-2364-Black	25	Black	12.50mm	50.00mm	12.50mm	25.00mm	25.00mm	M6 SHCS	M20 x 2.5	12.00mm	50.00mm	.0649 kg
40-2141	40	Clear	20.00mm	80.00mm	20.00mm	40.00mm	40.00mm	M8 SHCS	M12 x 1.75	19.00mm	80.00mm	.3065 kg
40-2141-Black	40	Black	20.00mm	80.00mm	20.00mm	40.00mm	40.00mm	M8 SHCS	M12 x 1.75	19.00mm	80.00mm	.3065 kg
40-2146	40	Clear	20.00mm	80.00mm	20.00mm	40.00mm	40.00mm	M8 SHCS	M16 x 2.0	19.00mm	80.00mm	.3030 kg
40-2146-Black	40	Black	20.00mm	80.00mm	20.00mm	40.00mm	40.00mm	M8 SHCS	M16 x 2.0	19.00mm	80.00mm	.3030 kg
40-2367	40	Clear	20.00mm	80.00mm	20.00mm	40.00mm	40.00mm	M8 SHCS	M20 x 2.5	19.00mm	80.00mm	.2963 kg
40-2367-Black	40	Black	20.00mm	80.00mm	20.00mm	40.00mm	40.00mm	M8 SHCS	M20 x 2.5	19.00mm	80.00mm	.2963 kg

Material Specifications

Material	Alloy*	Process	Finish
Aluminum	6105-T5	Milled	Anodize

* Or comparable

Required Machining Services

Machining Type	Machined	Reference Page
Tap Profile End	Mount to Profile End	853

Suggested Hardware (Mount to T-Slot)

Part No.	Series	Qty.	Bolt	T-Nut
3491	10	3	1/4-20 x 1/2" SHCS	Economy
3458	15	3	5/16-18 x 7/8" SHCS	Economy
75-3412	25	3	M6 x 12mm SHCS	Economy
75-3430	40	3	M8 x 20mm SHCS	Economy

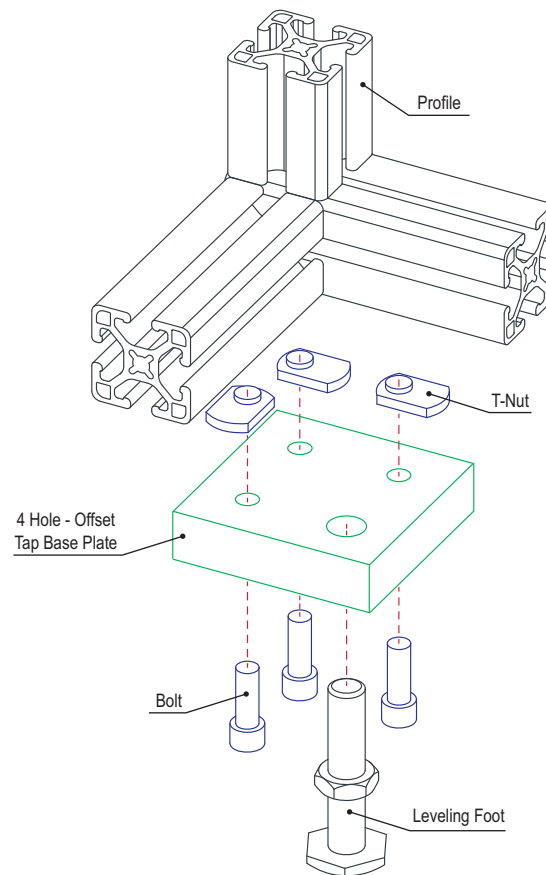

2 Hole - Leveling Anchoring Base Plate

Part Description:

The 2 hole – leveling anchoring base plate is made of anodized aluminum to withstand daily use and wear and tear. It mounts to a profile end and provides an offset hole that allows a leveling foot and floor anchor to be used at the same time. The extension pin helps align the base plate within the T-slot to keep the profile from rotating. A tap is required (page 853) to mount to the profile end.

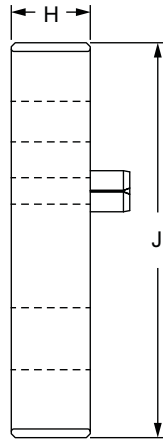
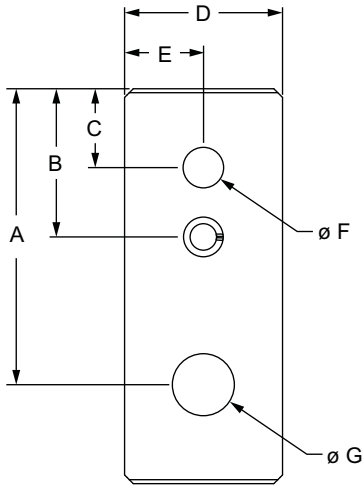

Part No.	Series	Color	A	B	C	D	E	F	G	H	J	Weight
2166	10	Clear	1.875"	.940"	.500"	1.000"	.500"	.257"	.390"	.500"	2.500"	.116 lb
2166-Black	10	Black	1.875"	.940"	.500"	1.000"	.500"	.257"	.390"	.500"	2.500"	.116 lb
2165	15	Clear	2.500"	1.410"	.750"	1.500"	.750"	.390"	.531"	.500"	3.000"	.215 lb
2165-Black	15	Black	2.500"	1.410"	.750"	1.500"	.750"	.390"	.531"	.500"	3.000"	.215 lb
40-2165	40	Clear	66.68mm	37.90mm	20.00mm	40.00mm	20.00mm	9.91mm	13.49mm	12.00mm	80.00mm	.1009 kg
40-2165-Black	40	Black	66.68mm	37.90mm	20.00mm	40.00mm	20.00mm	9.91mm	13.49mm	12.00mm	80.00mm	.1009 kg

Material Specifications

Material	Alloy*	Process	Finish
Aluminum	6105-T5	Milled	Anodize

* Or comparable

Required Machining Services

Machining Type	Machined	Reference Page
Tap Profile End	Mounting Profile	853

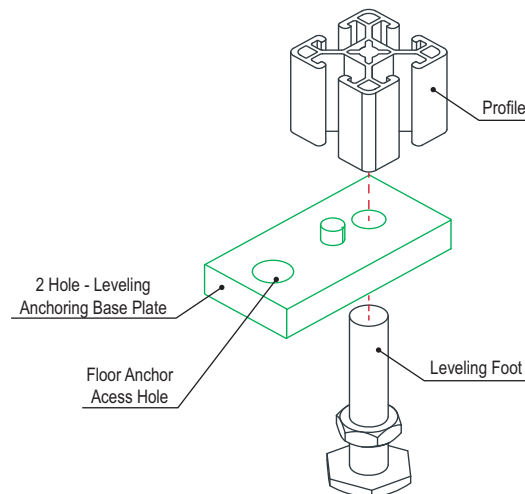

Part Description:

The 4 hole – leveling anchoring base plate is made of anodized aluminum to withstand daily use and wear and tear. It mounts to a profile end and provides an offset hole that allows a leveling foot and floor anchor to be used at the same time. The mounting hardware helps align the base plate within the T-slot to keep the profile from rotating. A tap is required (page 853) to mount to the profile end.

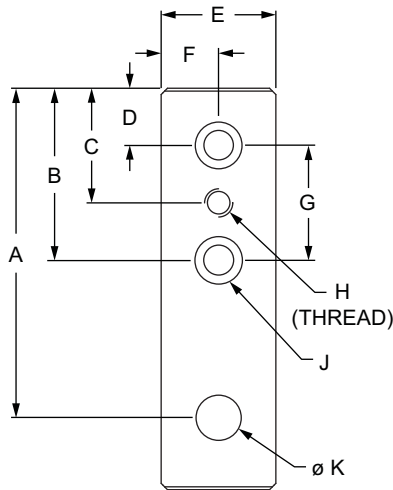

Part No.	Series	Color	A	B	C	D	E	F	G	H	J	K	L	M	Weight
2167	10	Clear	2.875"	1.500"	1.000"	.500"	1.000"	.500"	1.000"	1/4-20	1/4 SHCS	.390"	.500"	3.500"	.153 lb
2167-Black	10	Black	2.875"	1.500"	1.000"	.500"	1.000"	.500"	1.000"	1/4-20	1/4 SHCS	.390"	.500"	3.500"	.153 lb
2168	10	Clear	2.875"	1.500"	1.000"	.500"	1.000"	.500"	1.000"	3/8-16	1/4 SHCS	.390"	.500"	3.500"	.150 lb
2168-Black	10	Black	2.875"	1.500"	1.000"	.500"	1.000"	.500"	1.000"	3/8-16	1/4 SHCS	.390"	.500"	3.500"	.150 lb
2170	15	Clear	4.000"	2.250"	1.500"	.750"	1.500"	.750"	1.500"	3/8-16	5/16 SHCS	.531"	.750"	4.500"	.445 lb
2170-Black	15	Black	4.000"	2.250"	1.500"	.750"	1.500"	.750"	1.500"	3/8-16	5/16 SHCS	.531"	.750"	4.500"	.445 lb
2175	15	Clear	4.000"	2.250"	1.500"	.750"	1.500"	.750"	1.500"	1/2-13	5/16 SHCS	.531"	.750"	4.500"	.441 lb
2175-Black	15	Black	4.000"	2.250"	1.500"	.750"	1.500"	.750"	1.500"	1/2-13	5/16 SHCS	.531"	.750"	4.500"	.441 lb
40-2170	40	Clear	106.68mm	60.00mm	40.00mm	20.00mm	40.00mm	20.00mm	40.00mm	M10 x 1.50	M8 SHCS	13.50mm	19.00mm	120.00mm	.2216 kg
40-2170-Black	40	Black	106.68mm	60.00mm	40.00mm	20.00mm	40.00mm	20.00mm	40.00mm	M10 x 1.50	M8 SHCS	13.50mm	19.00mm	120.00mm	.2216 kg
40-2175	40	Clear	106.68mm	60.00mm	40.00mm	20.00mm	40.00mm	20.00mm	40.00mm	M12 x 1.75	M8 SHCS	13.50mm	19.00mm	120.00mm	.2199 kg
40-2175-Black	40	Black	106.68mm	60.00mm	40.00mm	20.00mm	40.00mm	20.00mm	40.00mm	M12 x 1.75	M8 SHCS	13.50mm	19.00mm	120.00mm	.2199 kg

4 Hole - Leveling Anchoring Base Plate (Continued)

Material Specifications

Material	Alloy*	Process	Finish
Aluminum	6105-T5	Milled	Anodize

* Or comparable

Required Machining Services

Machining Type	Machined	Reference Page
Tap Profile End	Mounting Profile	853

Suggested Hardware (Mount to T-Slot)

Part No.	Series	Qty.	Bolt	T-Nut
3491	10	2	1/4-20 x 1/2" SHCS	Economy
3458	15	2	5/16-18 x 7/8" SHCS	Economy
75-3430	40	2	M8 x 20mm SHCS	Economy

Suggested Hardware (Mount to Profile End)

Part No.	Series	Qty.	Bolt
3064	10	2	1/4-20 x 3/4" SHCS
3123	15	2	5/16-18 x 1.25" SHCS
13-8525	40	2	M8 x 25mm SHCS (Blue)

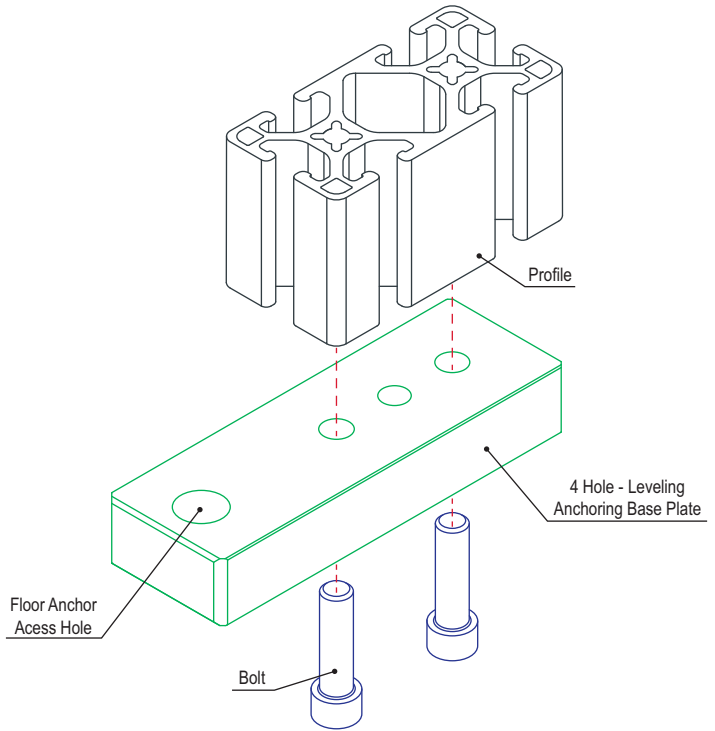

Part Description:

The 6 hole – leveling anchoring base plate is made of anodized aluminum to withstand daily use and wear and tear. It mounts to a profile end and provides an offset hole that allows a leveling foot and floor anchor to be used at the same time. A tap is required (page 853) to mount to the profile end.

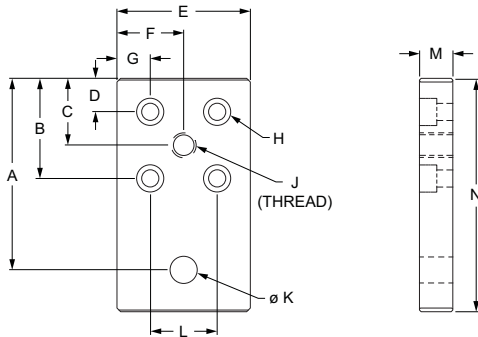

Part No.	Series	Color	A	B	C	D	E	F	G	H	J	K	L	M	N	Weight
2169	10	Clear	2.875"	1.500"	1.000"	.500"	2.000"	1.000"	.500"	1/4 SHCS	3/8-16	.390"	1.000"	.500"	3.500"	.308 lb
2169-Black	10	Black	2.875"	1.500"	1.000"	.500"	2.000"	1.000"	.500"	1/4 SHCS	3/8-16	.390"	1.000"	.500"	3.500"	.308 lb
2171	10	Clear	2.875"	1.500"	1.000"	.500"	2.000"	1.000"	.500"	1/4 SHCS	1/2-13	.390"	1.000"	.500"	3.500"	.305 lb
2171-Black	10	Black	2.875"	1.500"	1.000"	.500"	2.000"	1.000"	.500"	1/4 SHCS	1/2-13	.390"	1.000"	.500"	3.500"	.305 lb
2180	15	Clear	4.000"	2.250"	1.500"	.750"	3.000"	1.500"	.750"	5/16 SHCS	1/2-13	.531"	1.500"	.750"	4.500"	.921 lb
2180-Black	15	Black	4.000"	2.250"	1.500"	.750"	3.000"	1.500"	.750"	5/16 SHCS	1/2-13	.531"	1.500"	.750"	4.500"	.921 lb
40-2180	40	Clear	106.68mm	60.00mm	40.00mm	20.00mm	80.00mm	40.00mm	20.00mm	M8 SHCS	M12 x 1.75	13.50mm	40.00mm	19.00mm	120.00mm	.4557 kg
40-2180-Black	40	Black	106.68mm	60.00mm	40.00mm	20.00mm	80.00mm	40.00mm	20.00mm	M8 SHCS	M12 x 1.75	13.50mm	40.00mm	19.00mm	120.00mm	.4557 kg

Material Specifications

Material	Alloy*	Process	Finish
Aluminum	6105-T5	Milled	Anodize

* Or comparable

Required Machining Services

Machining Type	Machined	Reference Page
Tap Profile End	Mounting Profile	853

Suggested Hardware (Mount to T-Slot)

Part No.	Series	Qty.	Bolt	T-Nut
3491	10	4	1/4-20 x 1/2" SHCS	Economy
3458	15	4	5/16-18 x 7/8" SHCS	Economy
75-3430	40	4	M8 x 20mm SHCS	Economy

Suggested Hardware (Mount to Profile End)

Part No.	Series	Qty.	Bolt
3064	10	4	1/4-20 x 3/4" SHCS
3123	15	4	5/16-18 x 1.25" SHCS
13-8525	40	4	M8 x 25mm SHCS (Blue)

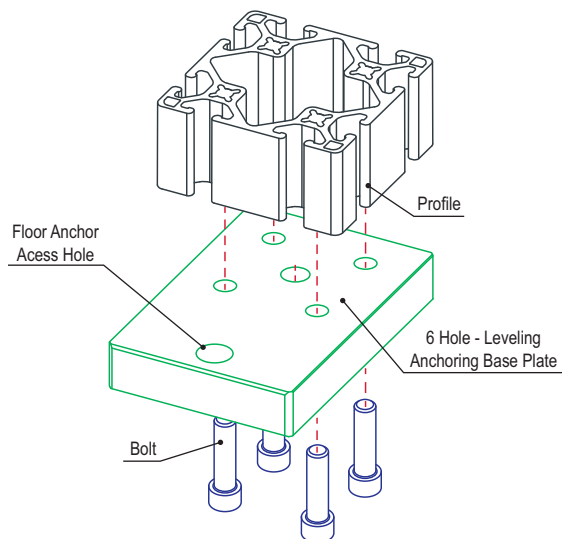

Floor Mount Base Plate

Part Description:

The floor mount base plate is made of anodized aluminum to withstand daily use and wear and tear. It has two upright plates that support the sides of the profile and enable vertical adjustments. The mount also has anchoring slots to bolt the frame to the floor; the slots allow lateral adjustments.

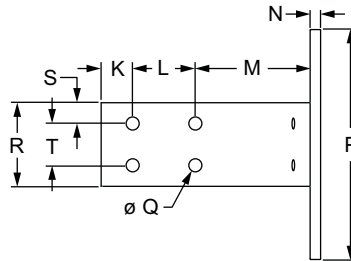
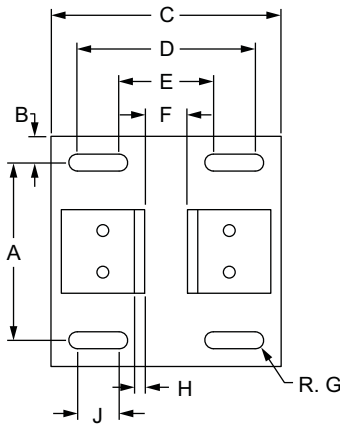

Part No.	Series	Color	A	B	C	D	E	F	G	H	J	
2380	10	Clear	2.750"	.625"	5.500"	4.250"	2.250"	1.020"	.203"	.250"	1.000"	
2380-Black	10	Black	2.750"	.625"	5.500"	4.250"	2.250"	1.020"	.203"	.250"	1.000"	
2385	10	Clear	4.250"	.625"	5.500"	4.250"	2.250"	1.020"	.203"	.250"	1.000"	
2385-Black	10	Black	4.250"	.625"	5.500"	4.250"	2.250"	1.020"	.203"	.250"	1.000"	
2387	10	Clear	4.250"	.625"	6.500"	5.250"	3.250"	2.020"	.203"	.250"	1.000"	
2387-Black	10	Black	4.250"	.625"	6.500"	5.250"	3.250"	2.020"	.203"	.250"	1.000"	
2390	15	Clear	3.750"	.625"	6.000"	4.750"	2.750"	1.520"	.265"	.250"	1.000"	
2390-Black	15	Black	3.750"	.625"	6.000"	4.750"	2.750"	1.520"	.265"	.250"	1.000"	
2400	15	Clear	4.750"	.625"	6.500"	5.250"	3.250"	1.520"	.265"	.250"	1.000"	
2400-Black	15	Black	4.750"	.625"	6.500"	5.250"	3.250"	1.520"	.265"	.250"	1.000"	
2410	15	Clear	4.750"	.625"	8.000"	6.750"	4.750"	3.020"	.265"	.250"	1.000"	
2410-Black	15	Black	4.750"	.625"	8.000"	6.750"	4.750"	3.020"	.265"	.250"	1.000"	
			K	L	M	N	P	Q	R	S	T	Weight
2380	10		.750"	1.500"	2.750"	.250"	4.000"	.281"	1.000"	.500"	—	.869 lb
2380-Black	10		.750"	1.500"	2.750"	.250"	4.000"	.281"	1.000"	.500"	—	.869 lb
2385	10		.750"	1.500"	2.750"	.250"	5.500"	.281"	2.000"	.500"	1.000"	1.474 lb
2385-Black	10		.750"	1.500"	2.750"	.250"	5.500"	.281"	2.000"	.500"	1.000"	1.474 lb
2387	10		.750"	1.500"	2.750"	.250"	5.500"	.281"	2.000"	.500"	1.000"	1.606 lb
2387-Black	10		.750"	1.500"	2.750"	.250"	5.500"	.281"	2.000"	.500"	1.000"	1.606 lb
2390	15		.750"	1.500"	2.750"	.375"	5.000"	.328"	1.500"	.750"	—	1.584 lb
2390-Black	15		.750"	1.500"	2.750"	.375"	5.000"	.328"	1.500"	.750"	—	1.584 lb
2400	15		.750"	1.500"	2.750"	.375"	6.000"	.328"	3.000"	.750"	1.500"	2.489 lb
2400-Black	15		.750"	1.500"	2.750"	.375"	6.000"	.328"	3.000"	.750"	1.500"	2.489 lb
2410	15		.750"	1.500"	2.750"	.375"	6.000"	.328"	3.000"	.750"	1.500"	2.822 lb
2410-Black	15		.750"	1.500"	2.750"	.375"	6.000"	.328"	3.000"	.750"	1.500"	2.822 lb

CONTINUE



Floor Mount Base Plate (Continued)

Part No.	Series	Color	A	B	C	D	E	F	G	H	J
25-2380	25	Clear	70.00mm	15.00mm	160.00mm	130.00mm	70.00mm	25.40mm	6.50mm	6.00mm	30.00mm
25-2380-Black	25	Black	70.00mm	15.00mm	160.00mm	130.00mm	70.00mm	25.40mm	6.50mm	6.00mm	30.00mm
25-2385	25	Clear	110.00mm	15.00mm	160.00mm	130.00mm	70.00mm	80.40mm	6.50mm	6.00mm	30.00mm
25-2385-Black	25	Black	110.00mm	15.00mm	160.00mm	130.00mm	70.00mm	80.40mm	6.50mm	6.00mm	30.00mm
25-2387	25	Clear	110.00mm	15.00mm	182.00mm	152.00mm	92.00mm	50.40mm	6.50mm	6.00mm	30.00mm
25-2387-Black	25	Black	110.00mm	15.00mm	182.00mm	152.00mm	92.00mm	50.40mm	6.50mm	6.00mm	30.00mm
40-2390	40	Clear	110.00mm	15.00mm	160.00mm	130.00mm	70.00mm	40.40mm	6.75mm	6.00mm	30.00mm
40-2390-Black	40	Black	110.00mm	15.00mm	160.00mm	130.00mm	70.00mm	40.40mm	6.75mm	6.00mm	30.00mm
40-2400	40	Clear	130.00mm	15.00mm	160.00mm	130.00mm	70.00mm	40.40mm	6.75mm	6.00mm	30.00mm
40-2400-Black	40	Black	130.00mm	15.00mm	160.00mm	130.00mm	70.00mm	40.40mm	6.75mm	6.00mm	30.00mm
40-2410	40	Clear	130.00mm	15.00mm	200.00mm	170.00mm	110.00mm	80.40mm	6.75mm	6.00mm	30.00mm
40-2410-Black	40	Black	130.00mm	15.00mm	200.00mm	170.00mm	110.00mm	80.40mm	6.75mm	6.00mm	30.00mm
		K	L	M	N	P	Q	R	S	T	Weight
25-2380	25	20.00mm	40.00mm	80.00mm	6.00mm	100.00mm	7.14mm	25.00mm	12.50mm	—	.4074 kg
25-2380-Black	25	20.00mm	40.00mm	80.00mm	6.00mm	100.00mm	7.14mm	25.00mm	12.50mm	—	.4074 kg
25-2385	25	20.00mm	40.00mm	80.00mm	6.00mm	140.00mm	7.14mm	50.00mm	12.50mm	25.00mm	.6977 kg
25-2385-Black	25	20.00mm	40.00mm	80.00mm	6.00mm	140.00mm	7.14mm	50.00mm	12.50mm	25.00mm	.6977 kg
25-2387	25	20.00mm	40.00mm	80.00mm	6.00mm	140.00mm	7.14mm	50.00mm	12.50mm	25.00mm	.7395 kg
25-2387-Black	25	20.00mm	40.00mm	80.00mm	6.00mm	140.00mm	7.14mm	50.00mm	12.50mm	25.00mm	.7395 kg
40-2390	40	20.00mm	40.00mm	80.00mm	9.00mm	140.00mm	8.33mm	40.00mm	20.00mm	—	.7951 kg
40-2390-Black	40	20.00mm	40.00mm	80.00mm	9.00mm	140.00mm	8.33mm	40.00mm	20.00mm	—	.7951 kg
40-2400	40	20.00mm	40.00mm	80.00mm	9.00mm	160.00mm	8.33mm	80.00mm	20.00mm	40.00mm	1.1653 kg
40-2400-Black	40	20.00mm	40.00mm	80.00mm	9.00mm	160.00mm	8.33mm	80.00mm	20.00mm	40.00mm	1.1653 kg
40-2410	40	20.00mm	40.00mm	80.00mm	9.00mm	160.00mm	8.33mm	80.00mm	20.00mm	40.00mm	1.3245 kg
40-2410-Black	40	20.00mm	40.00mm	80.00mm	9.00mm	160.00mm	8.33mm	80.00mm	20.00mm	40.00mm	1.3245 kg

Material Specifications

Material	Alloy*	Process	Finish
Aluminum	6105-T5	Milled	Anodize

* Or comparable

Suggested Hardware (Mount to T-Slot)

Part No.	Series	Qty.	Bolt Assembly
3321	10	4 TO 8	1/4-20 x 1/2" FBHSCS & Economy T-Nut
3325	15	4 TO 8	5/16-18 x 3/4" Economy T-Slot Stud w/ Washer & Hex Nut
3320	15	4 TO 8	5/16-18 x 11/16" FBHSCS & Economy T-Nut
75-3412	25	4 TO 8	M6 x 12mm SHCS & Economy T-Nut
75-3500	40	4 TO 8	M8 x 20mm Economy T-Slot Stud w/ Washer & Hex Nut
75-3422	40	4 TO 8	M8 x 16mm BHSCS & Economy T-Nut

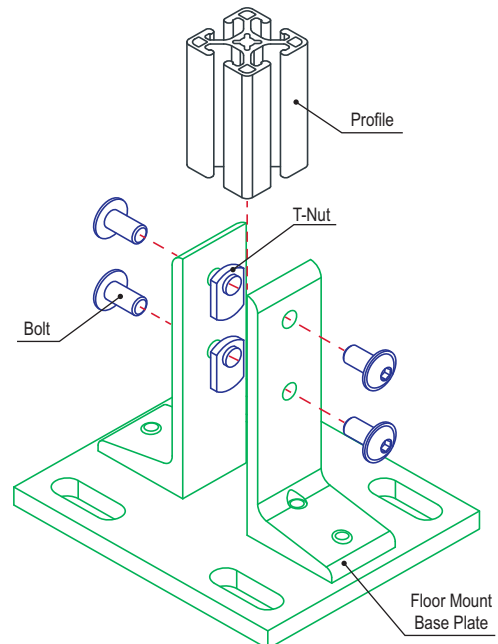

Economy Floor Mount Base Plate

80/20[®] Inc.

Part Description:

The economy floor mount base plate is made of anodized aluminum to withstand daily use and wear and tear. It bolts directly to the T-slot to allow vertical adjustments and is designed with countersunk holes to incorporate floor anchors.

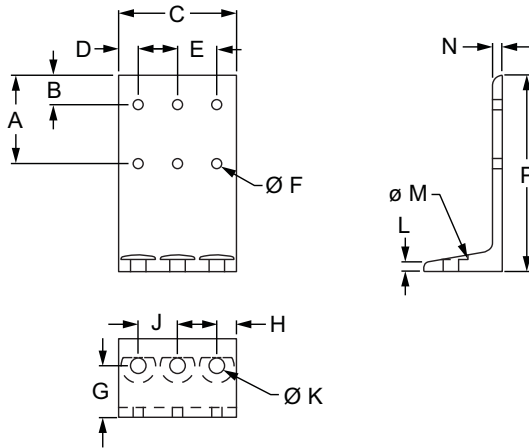

Part No.	Series	Color	A	B	C	D	E	F	G	H
2414	10	Clear	2.250"	.750"	1.000"	.500"	—	.257"	1.312"	.500"
2414-Black	10	Black	2.250"	.750"	1.000"	.500"	—	.257"	1.312"	.500"
2416	10	Clear	2.250"	.750"	2.000"	.500"	1.000"	.257"	1.312"	.500"
2416-Black	10	Black	2.250"	.750"	2.000"	.500"	1.000"	.257"	1.312"	.500"
2404	10	Clear	2.250"	.750"	3.000"	.500"	1.000"	.257"	1.312"	.500"
2404-Black	10	Black	2.250"	.750"	3.000"	.500"	1.000"	.257"	1.312"	.500"
2415	15	Clear	2.250"	.750"	1.500"	.750"	—	.328"	1.312"	.750"
2415-Black	15	Black	2.250"	.750"	1.500"	.750"	—	.328"	1.312"	.750"
2417	15	Clear	2.250"	.750"	3.000"	.750"	1.500"	.328"	1.312"	.750"
2417-Black	15	Black	2.250"	.750"	3.000"	.750"	1.500"	.328"	1.312"	.750"
2405	15	Clear	2.250"	.750"	4.500"	.750"	1.500"	.328"	1.312"	.750"
2405-Black	15	Black	2.250"	.750"	4.500"	.750"	1.500"	.328"	1.312"	.750"
			J	K	L	M	N	P	Q	Weight
2414	10	Clear	—	.390"	.312"	.875"	.250"	5.000"	2.000"	.178 lb
2414-Black	10	Black	—	.390"	.312"	.875"	.250"	5.000"	2.000"	.178 lb
2416	10	Clear	1.000"	.390"	.312"	.875"	.250"	5.000"	2.000"	.270 lb
2416-Black	10	Black	1.000"	.390"	.312"	.875"	.250"	5.000"	2.000"	.270 lb
2404	10	Clear	1.000"	.390"	.312"	.875"	.250"	5.000"	2.000"	.545 lb
2404-Black	10	Black	1.000"	.390"	.312"	.875"	.250"	5.000"	2.000"	.545 lb
2415	15	Clear	—	.531"	.312"	1.125"	.250"	5.000"	2.000"	.263 lb
2415-Black	15	Black	—	.531"	.312"	1.125"	.250"	5.000"	2.000"	.263 lb
2417	15	Clear	1.500"	.531"	.312"	1.125"	.250"	5.000"	2.000"	.545 lb
2417-Black	15	Black	1.500"	.531"	.312"	1.125"	.250"	5.000"	2.000"	.545 lb
2405	15	Clear	1.500"	.531"	.312"	1.125"	.250"	5.000"	2.000"	.785 lb
2405-Black	15	Black	1.500"	.531"	.312"	1.125"	.250"	5.000"	2.000"	.785 lb

CONTINUE



Economy Floor Mount Base Plate (Continued)

Part No.	Series	Color	A	B	C	D	E	F	G	H
25-2414	25	Clear	60.00mm	20.00mm	25.00mm	12.50mm	—	6.30mm	36.00mm	12.50mm
25-2414-Black	25	Black	60.00mm	20.00mm	25.00mm	12.50mm	—	6.30mm	36.00mm	12.50mm
25-2416	25	Clear	60.00mm	20.00mm	50.00mm	12.50mm	25.00mm	6.30mm	36.00mm	12.50mm
25-2416-Black	25	Black	60.00mm	20.00mm	50.00mm	12.50mm	25.00mm	6.30mm	36.00mm	12.50mm
40-2415	40	Clear	60.00mm	20.00mm	40.00mm	20.00mm	—	8.33mm	36.00mm	20.00mm
40-2415-Black	40	Black	60.00mm	20.00mm	40.00mm	20.00mm	—	8.33mm	36.00mm	20.00mm
40-2417	40	Clear	60.00mm	20.00mm	80.00mm	20.00mm	40.00mm	8.33mm	36.00mm	20.00mm
40-2417-Black	40	Black	60.00mm	20.00mm	80.00mm	20.00mm	40.00mm	8.33mm	36.00mm	20.00mm
			J	K	L	M	N	P	Q	Weight
25-2414	25	Clear	—	10.49mm	8.00mm	22.00mm	6.00mm	140.00mm	50.00mm	.0846 kg
25-2414-Black	25	Black	—	10.49mm	8.00mm	22.00mm	6.00mm	140.00mm	50.00mm	.0846 kg
25-2416	25	Clear	25.00mm	10.49mm	8.00mm	22.00mm	6.00mm	140.00mm	56.00mm	.1679 kg
25-2416-Black	25	Black	25.00mm	10.49mm	8.00mm	22.00mm	6.00mm	140.00mm	56.00mm	.1679 kg
40-2415	40	Clear	—	13.49mm	8.00mm	28.00mm	6.00mm	140.00mm	56.00mm	.1406 kg
40-2415-Black	40	Black	—	13.49mm	8.00mm	28.00mm	6.00mm	140.00mm	56.00mm	.1406 kg
40-2417	40	Clear	40.00mm	13.49mm	8.00mm	28.00mm	6.00mm	140.00mm	56.00mm	.2680 kg
40-2417-Black	40	Black	40.00mm	13.49mm	8.00mm	28.00mm	6.00mm	140.00mm	56.00mm	.2680 kg

Material Specifications

Material	Alloy*	Process	Finish
Aluminum	6105-T5	Milled	Anodize

* Or comparable

Suggested Hardware (Mount to T-Slot)

Part No.	Series	Qty.	Bolt Assembly
3321	10	2 TO 6	1/4-20 x 1/2" FBHSCS & Economy T-Nut
3325	15	2 TO 6	5/16-18 x 3/4" Economy T-Slot Stud w/ Washer & Hex Nut
3320	15	2 TO 6	5/16-18 x 11/16" FBHSCS & Economy T-Nut
75-3412	25	2 TO 6	M6 x 12mm SHCS & Economy T-Nut
75-3500	40	2 TO 6	M8 x 20mm Economy T-Slot Stud w/ Washer & Hex Nut
75-3422	40	2 TO 6	M8 x 16mm BHSCS & Economy T-Nut

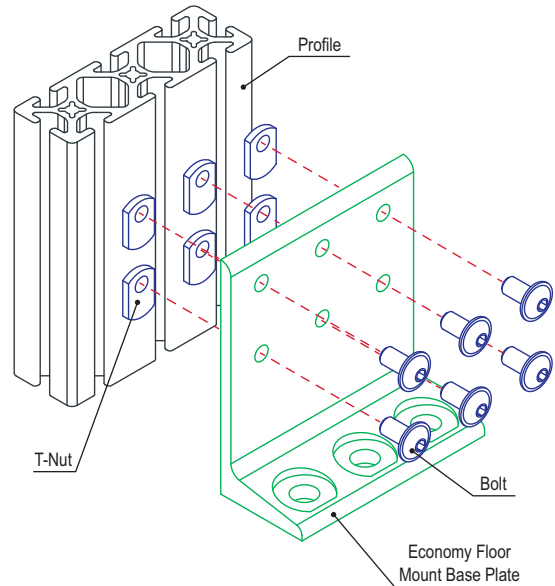

Slotted Economy Floor Mount Base Plate

Part Description:

The slotted economy floor mount base plate is available in clear or black anodized aluminum to withstand daily use and wear and tear. It has slotted holes to assist with positioning and adjustments, making it a common choice for use with Ready Tube™. The base plate is designed with a countersunk hole to incorporate floor anchors.

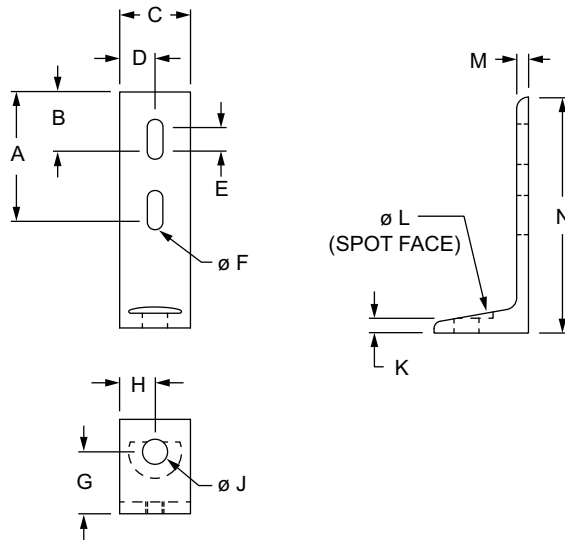

Part No.	Series	Color	A	B	C	D	E	F	G	
2413	15 RT	Clear	2.750"	1.250"	1.500"	.750"	.500"	.328"	1.312"	
2413-Black	15 RT	Black	2.750"	1.250"	1.500"	.750"	.500"	.328"	1.312"	
			H	J	K	L	M	N	P	Weight
2413	15 RT		.750"	.530"	.312"	1.125"	.250"	5.000"	2.000"	.255 lb
2413-Black	15 RT		.750"	.530"	.312"	1.125"	.250"	5.000"	2.000"	.255 lb

Material Specifications

Material	Alloy*	Process	Finish
Aluminum	6105-T5	Milled	Anodize

* Or comparable

Suggested Hardware (Mount to T-Slot)

Part No.	Series	Qty.	Bolt	T-Nut
3320	15	2	5/16-18 x .687" FBHSCS	Economy
3960	RT	2	5/16-18 x 2.000" Flanged Hex Head Bolt	Flanged Hex Nut

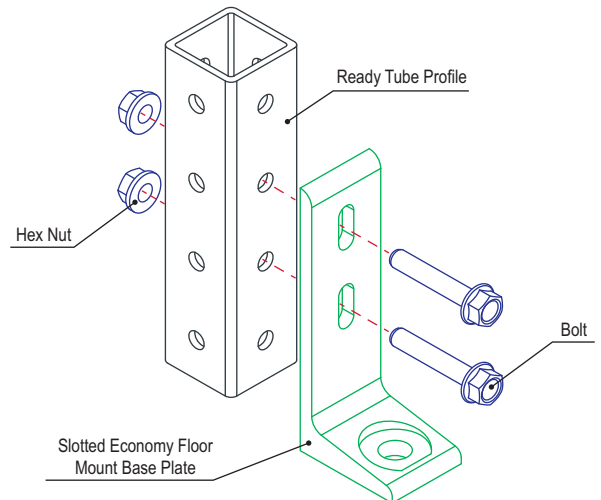

Part Description:

The 3 hole – die-cast center tap base plate has a black powder coat finish. It mounts leveling feet and threaded stem casters, and is commonly used on a rectangular profile end to center mount the foot or caster. This base plate can also be used on a profile side. It requires a tap (page 853) to mount to a profile end. **Additional Information:** When using an M12 socket head cap screw (SHCS) the base plate can only be mounted to the profile end.

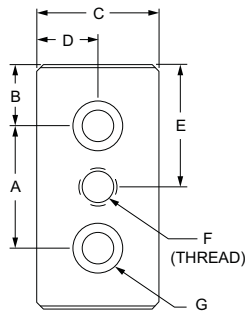

Part No.	Series	Color	A	B	C	D	E	F	G	H	J	Weight
14021	30	Black	30.00mm	15.00mm	30.00mm	15.00mm	30.00mm	M8 x 1.25	M8 SHCS	12.00mm	60.00mm	.2100 kg
14023	30		30.00mm	15.00mm	30.00mm	15.00mm	30.00mm	M10 x 1.50	M8 SHCS	12.00mm	60.00mm	.2030 kg
14025	30		30.00mm	15.00mm	30.00mm	15.00mm	30.00mm	M12 x 1.75	M8 SHCS	12.00mm	60.00mm	.2000 kg
14027	45		45.00mm	22.50mm	45.00mm	22.50mm	45.00mm	M10 x 1.50	M8 SHCS	16.00mm	90.00mm	.2803 kg
14028	45		45.00mm	22.50mm	45.00mm	22.50mm	45.00mm	M10 x 1.50	M12 SHCS	16.00mm	90.00mm	.2521 kg
14029	45		45.00mm	22.50mm	45.00mm	22.50mm	45.00mm	M12 x 1.75	M8 SHCS	16.00mm	90.00mm	.6160 kg
14030	45		45.00mm	22.50mm	45.00mm	22.50mm	45.00mm	M12 x 1.75	M12 SHCS	16.00mm	90.00mm	.5570 kg
14032	45		45.00mm	22.50mm	45.00mm	22.50mm	45.00mm	M16 x 2.0	M12 SHCS	16.00mm	90.00mm	.5390 kg

Material Specifications

Material	Grade	Process	Finish
Zinc	GD-ZnAlCu1	Die Cast	Powder Coat

Required Machining Services

Machining Type	Machined	Reference Page
Tap Profile End	Mount to Profile End	853

Suggested Hardware (Mount to T-Slot)

Series	Qty.	Part No.	Bolt	Qty.	Part No.	T-Nut
30	2	11-8512	M8 x 12mm SHCS	2	13095	Roll-in
45	2	11-8520	M8 x 20mm SHCS	2	13132	Drop-in

Suggested Hardware (Mount to Profile End)

Part No.	Series	Qty.	Bolt
11-8520	30	2	M8 x 20mm SHCS
11-2525	45	2	M12 x 25mm LHSCS

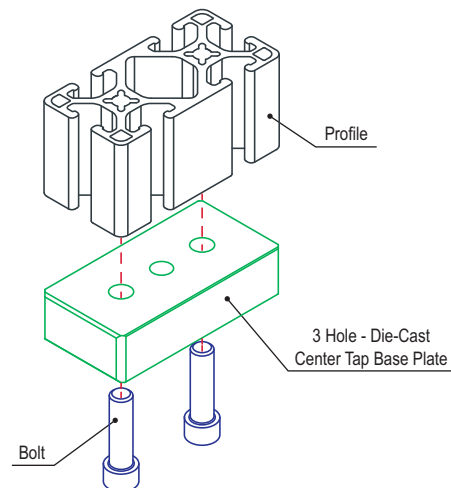

5 Hole - Die-Cast Center Tap Base Plate

Part Description:

The 5 hole – die-cast center tap base plate has a black powder coat finish. It mounts leveling feet and threaded stem casters, and is commonly used on profiles with eight slots to center mount the foot or caster. This base plate can also be used on a profile side. It requires a tap (page 853) to mount to a profile end. **Additional Information:** When using an M12 socket head cap screw (SHCS) the base plate can only be mounted to the profile end.

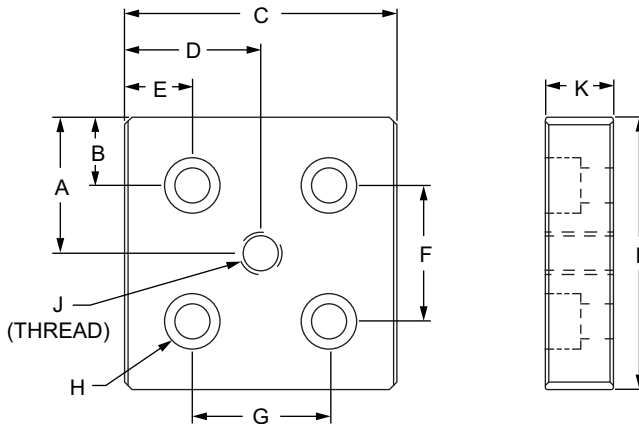

Part No.	Series	Color	A	B	C	D	E	F	G	H	J	K	L	Weight
14035	30	Black	30.00mm	15.00mm	60.00mm	30.00mm	15.00mm	30.00mm	30.00mm	M8 SHCS	M8 x 1.25	12.00mm	60.00mm	.3710 kg
14037	30		30.00mm	15.00mm	60.00mm	30.00mm	15.00mm	30.00mm	30.00mm	M8 SHCS	M10 x 1.50	12.00mm	60.00mm	.3520 kg
14039	30		30.00mm	15.00mm	60.00mm	30.00mm	15.00mm	30.00mm	30.00mm	M8 SHCS	M12 x 1.75	12.00mm	60.00mm	.3470 kg
14041	30		30.00mm	15.00mm	60.00mm	30.00mm	15.00mm	30.00mm	30.00mm	M8 SHCS	M16 x 2.0	12.00mm	60.00mm	.3390 kg
14043	45		45.00mm	22.50mm	90.00mm	45.00mm	22.50mm	45.00mm	45.00mm	M12 SHCS	M10 x 1.50	16.00mm	90.00mm	1.0680 kg
14045	45		45.00mm	22.50mm	90.00mm	45.00mm	22.50mm	45.00mm	45.00mm	M12 SHCS	M12 x 1.75	16.00mm	90.00mm	1.0680 kg
14047	45		45.00mm	22.50mm	90.00mm	45.00mm	22.50mm	45.00mm	45.00mm	M12 SHCS	M16 x 2.0	16.00mm	90.00mm	1.0380 kg

Material Specifications

Material	Grade	Process	Finish
Zinc	GD-ZnAlCu1	Die Cast	Powder Coat

Required Machining Services

Machining Type	Machined	Reference Page
Tap Profile End	Mount to Profile End	853

Suggested Hardware (Mount to T-Slot)

Part No.	Series	Qty.	Bolt	T-Nut
75-3595	30	4	M6 x 16mm SHCS	Drop-in

Suggested Hardware (Mount to Profile End)

Part No.	Series	Qty.	Bolt
11-8518	30	4	M8 x 18mm SHCS
11-2525	45	4	M12 x 25mm LHSCS

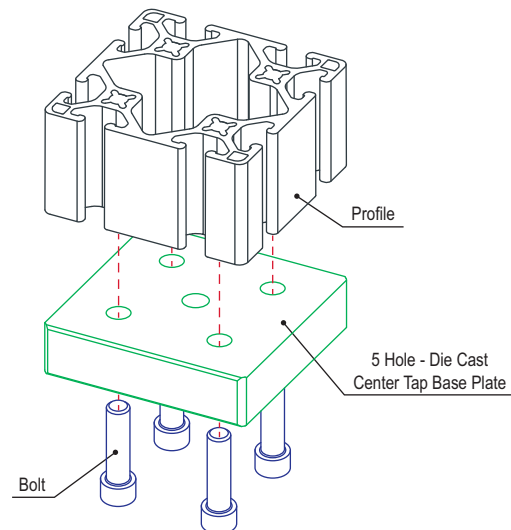

Pictorial Table Of Contents



Linear Bearing Concept

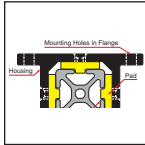

Page 658

Bearing Pad Types



Page 658

UniBearings™



Page 659

Introduction to Axial Motion

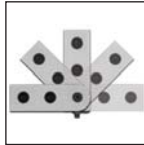

Page 709

Dynamic Pivot Components



Page 709

Introduction to Pressure Manifolds



Page 749

Introduction to Stanchions



Page 765

Linear Motion

3 Slot Mount - Single Flange Short Standard Linear Bearing



Page 660

3 Slot Mount - Single Flange Long Standard Linear Bearing



Page 662

3 Slot Mount - Double Flange Short Standard Linear Bearing



Page 664

3 Slot Mount - Double Flange Long Standard Linear Bearing



Page 666

4 Slot Mount - Double Flange Short Standard Linear Bearing



Page 668

4 Slot Mount - Double Flange Long Standard Linear Bearing



Page 670

3 Slot Mount - Single Flange Short High-Cycle Linear Bearing



Page 672

3 Slot Mount - Single Flange Long High-Cycle Linear Bearing



Page 674

3 Slot Mount - Double Flange Short High-Cycle Linear Bearing



Page 676

3 Slot Mount - Double Flange Long High-Cycle Linear Bearing



Page 678

4 Slot Mount - Double Flange Short High-Cycle Linear Bearing



Page 680

4 Slot Mount - Double Flange Long High-Cycle Linear Bearing



Page 682

Single Short UniBearing™



Page 684

Single Long UniBearing™



Page 685

Double Short UniBearing™



Page 686

Double Long UniBearing™



Page 687

Short - Single Mount UniBearing™ Assy.



Page 688

Long - Single Mount UniBearing™ Assy.



Page 689

Short - Double Mount UniBearing™ Assy.



Page 690

Long - Double Mount UniBearing™ Assy.



Page 691

CONTINUE



Pictorial Table Of Contents

Linear Bearing Pads, Shims, Brakes

Single-Keyed Standard Linear Bearing Pad



Page 696

Single-Keyed High-Cycle Linear Bearing Pad



Page 697

T-Slot Insert Linear Bearing Pad



Page 698

Single-Keyed UniBearing™ Pad



Page 699

Double-Keyed UniBearing™ Pad



Page 700

Single-Keyed Standard Bearing Pad Profile



Page 701

Double-Keyed Standard Bearing Pad Profile



Page 702

Linear Bearing Shim Stock



Page 703

“L” Handle Linear Bearing Brake Kit



Page 704

“T” Handle Linear Bearing Brake Kit



Page 705

Hex Nut Linear Bearing Brake Kit



Page 706

Wing Nut Linear Bearing Brake Kit



Page 707

Star Handle Linear Bearing Brake Kit



Page 708

Dynamic Pivots

0 Degree Dynamic Pivot Nub



Page 710

90 Degree Dynamic Pivot Nub



Page 711

Universal Dynamic Pivot Nub



Page 712

0 Degree Dynamic Right Angle Pivot Nub



Page 713

90 Degree Dynamic Right Angle Pivot Nub



Page 714

Universal Dynamic Right Angle Pivot Nub



Page 715

“L” Dynamic Pivot Arm



Page 716

Standard Straight Dynamic Pivot Arm



Page 717

Standard 0 Degree Dynamic Pivot Assy. with Dual Straight Arms



Page 718

Standard 90 Degree Dynamic Pivot Assy. with Dual Straight Arms



Page 719

Standard Universal Dynamic Pivot Assy. with Dual Straight Arms



Page 720

Standard 0 Degree Dynamic Pivot Assy. with Dual “L” Arms



Page 721

Standard 90 Degree Dynamic Pivot Assy. with Dual “L” Arms



Page 722

Standard Universal Dynamic Pivot Assy. with Dual “L” Arms



Page 723

CONTINUE

Pictorial Table Of Contents



**Standard 0 Degree
Dynamic Pivot
Assy. with Straight
and "L" Arm**



Page 724

**Standard 90 Degree
Dynamic Pivot
Assy. with Straight
and "L" Arm**



Page 725

**Standard Universal
Dynamic Pivot
Assy. with Straight
and "L" Arm**



Page 726

**Right Angle
0 Degree Dynamic
Pivot Assy. with
Dual Straight Arms**



Page 727

**Right Angle
90 Degree Dynamic
Pivot Assy. with
Dual Straight Arms**



Page 728

**Right Angle
Universal Dynamic
Pivot Assy. with
Dual Straight Arms**



Page 729

**Right Angle
0 Degree Dynamic
Pivot Assy. with
Dual "L" Arms**



Page 730

**Right Angle
90 Degree Dynamic
Pivot Assy. with
Dual "L" Arms**



Page 731

**Right Angle
Universal Dynamic
Pivot Assy. with
Dual "L" Arms**



Page 732

**90 Degree
Left Hand Pivot
Bracket Plate**



Page 733

**90 Degree
Right Hand Pivot
Bracket Plate**



Page 734

**90 Degree
Left Hand Pivot
Bracket Assy.
with "L" Handle**



Page 735

**90 Degree
Left Hand Pivot
Bracket Assy.
with "T" Handle**



Page 736

**90 Degree
Right Hand Pivot
Bracket Assy.
with "L" Handle**



Page 737

**90 Degree
Right Hand Pivot
Bracket Assy.
with "T" Handle**



Page 738

**90 Degree Double
Pivot Bracket Assy.
with "L" Handles**



Page 739

**90 Degree Double
Pivot Bracket Assy.
with "T" Handles**



Page 740

**90 Degree Wide
Double Pivot
Bracket Assy.
with "L" Handles**



Page 741

**90 Degree Wide
Double Pivot
Bracket Assy.
with "T" Handles**



Page 742

**180 Degree
Pivot Bracket**



Page 743

**180 Degree
Right Hand Pivot
Bracket Assy.
with "L" Handle**



Page 744

**180 Degree Double
Pivot Bracket Assy.
with "L" Handles**



Page 745

**180 Degree Wide
Double Pivot
Bracket Assy.
with "L" Handle**



Page 746

**"L" Handle Kit -
Dynamic Pivot**



Page 747

**"T" Handle Kit -
Dynamic Pivot**



































Page 748

CONTINUE



Pictorial Table Of Contents

Manifolds, Gravity Rollers and Stanchions

<p>3-Hole Pressure Manifold Feed Plate</p>  <p>Page 750</p>	<p>3-Hole Gasket for Pressure Manifold</p>  <p>Page 750</p>	<p>2-Hole Pressure Manifold Stopper Plate</p>  <p>Page 751</p>	<p>5-Hole Square Pressure Manifold Feed Plate</p>  <p>Page 752</p>	<p>5-Hole Square Gasket for Pressure Manifold</p>  <p>Page 752</p>	<p>4-Hole Pressure Manifold Stopper Plate</p>  <p>Page 753</p>	<p>5-Hole Rectangular Pressure Manifold Feed Plate</p>  <p>Page 754</p>
<p>5-Hole Rectangular Gasket for Pressure Manifold</p>  <p>Page 754</p>	<p>3-Hole Pressure Manifold Stopper Plate</p>  <p>Page 755</p>	<p>12-Hole Pressure Manifold Feed Plate</p>  <p>Page 756</p>	<p>12-Hole Gasket for Pressure Manifold</p>  <p>Page 756</p>	<p>8-Hole Pressure Manifold Stopper Plate</p>  <p>Page 757</p>	<p>Pressure Manifold Access Plate</p>  <p>Page 758</p>	<p>Pressure Manifold Tap Ready Access Plate</p>  <p>Page 759</p>
<p>Gravity Roller</p>  <p>Page 760</p>	<p>Gravity Roller Mounting Block</p>  <p>Page 761</p>	<p>Connector Rod</p>  <p>Page 762</p>	<p>Connector Rod Profile</p>  <p>Page 762</p>	<p>P-Tube Stopper</p>  <p>Page 763</p>		
<p>Single Shaft Stanchion Base</p>  <p>Page 766</p>	<p>Double Shaft Stanchion Base</p>  <p>Page 767</p>	<p>Single Shaft Blank Stanchion Mounting Plate</p>  <p>Page 768</p>	<p>Single Shaft Pre-Drilled Stanchion Mounting Plate</p>  <p>Page 769</p>	<p>Double Shaft Blank Stanchion Mounting Plate</p>  <p>Page 770</p>	<p>Double Shaft Pre-Drilled Stanchion Mounting Plate</p>  <p>Page 771</p>	<p>Stanchion Cross Clamp</p>  <p>Page 772</p>
<p>Single Shaft Stanchion Mounting Block</p>  <p>Page 773</p>	<p>Double Shaft Stanchion Mounting Block</p>  <p>Page 775</p>	<p>Narrow Horizontal Stanchion Base</p>  <p>Page 776</p>	<p>Wide Horizontal Stanchion Base</p>  <p>Page 777</p>	<p>Horizontal Stanchion Quick Clamp</p>  <p>Page 778</p>	<p>Quick Stanchion Cross Clamp</p>  <p>Page 779</p>	<p>Stanchion Clamp Handle</p>  <p>Page 780</p>

80/20 AutoQuoter X II

Tips & Tricks



Visit the
80/20® Channel

- How-To Videos



- Tips and Tricks

Watch Now!



www.youtube.com/8020inc



Linear Bearing Concept

Linear bearings enable you to add repeated motion and movement to your project. As an example, linear bearings are commonly found in material transportation applications such as picking tools.

The core concept is that profiles act as guiderails and pads are inserted into the T-slot to enable movement. Pads are available in two options: standard or high-cycle.

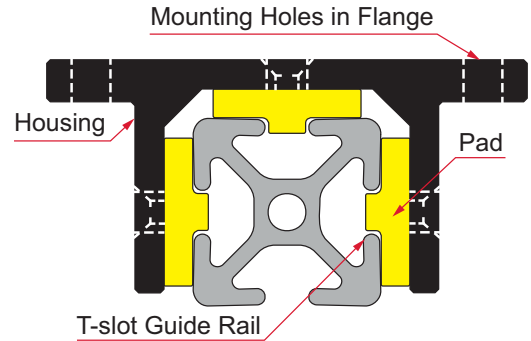

Standard Pad

Perfect for solutions such as drawer glides, table saw fences, ergonomic workstations or adjustable stands. All pads are available in white and black styles.



High-Cycle Pad

These bearings have a special threaded insert designed for sudden acceleration and deceleration without deteriorating. This durable pad lends itself to actuators and parts-transfer equipment.

Linear Bearing Shims

Linear bearing shim stock is used to create a precise fit. Each shim is .005 inches (.127mm) thick and has a slotted design that enables easy installation without having to dismantle the bearing; simply loosen the bearing pad and slide the shim(s) between the pad and housing while the bearing is still in place. Shims are sold in packs of 10 and are compatible with all 80/20 bearings.

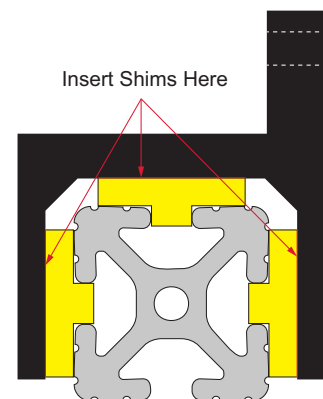



UniBearing™ Concept

80/20 offers a custom UniBearing™. It differs from the traditional linear bearing in that it is adjustable for a range of profiles and can be installed even when a T-slot profile is captivated.



These are easily integrated into existing structures and are commonly used in applications such as automation equipment or guards that require frequent movement.

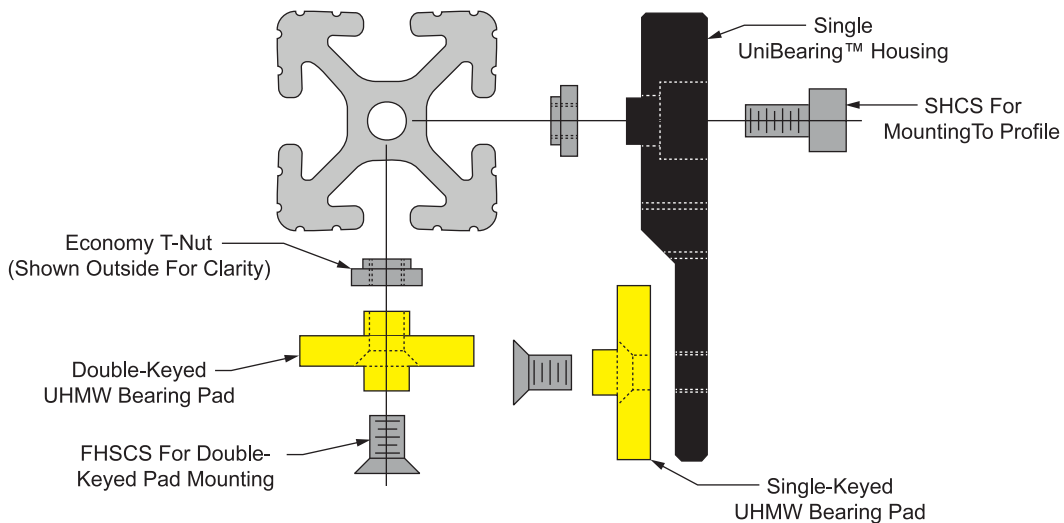
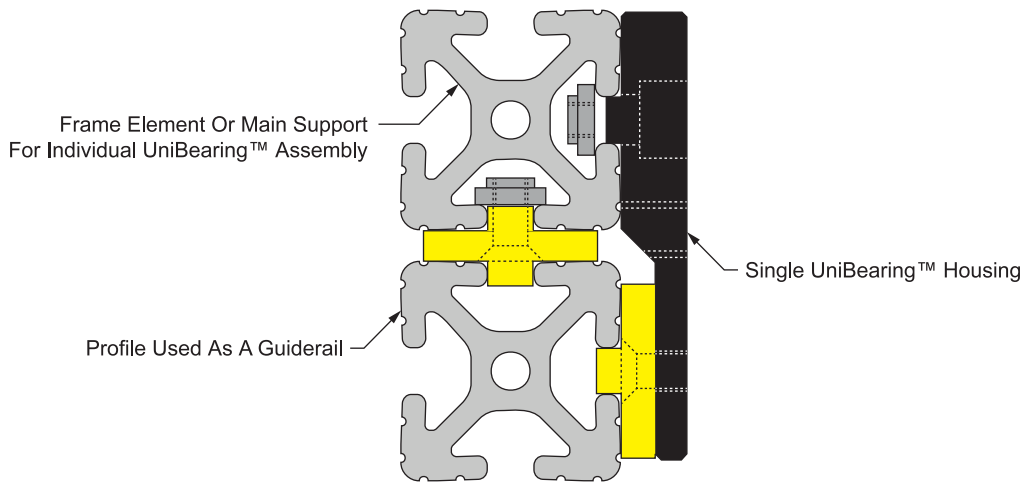

3 Slot Mount - Single Flange Short Standard Linear Bearing

Part Description:

The 3 slot mount – single flange short standard linear bearing with or without brake holes is typically used in linear motion applications. It houses profiles with a minimum of three open T-slots, has a single flange and is a shorter option. The bearing includes pads, screws and shims; the pads are made of self-lubricating UHMW. All 80/20 bearings are designed for compression loads only and not intended to support hanging loads.



Fractional



Metric



Black Anodized

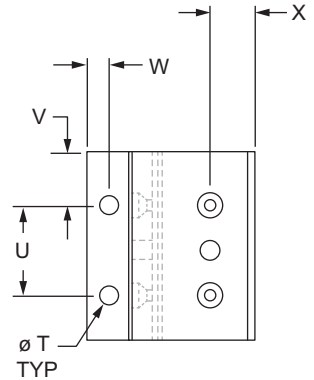
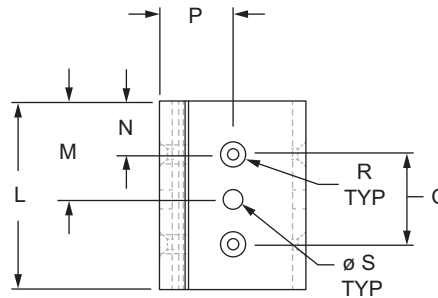
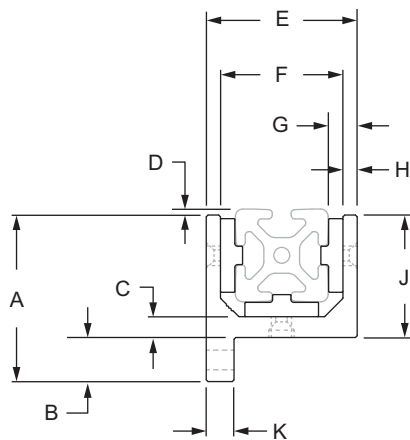

CONTINUE

3 Slot Mount - Single Flange Short Standard Linear Bearing (Continued)

3 Slot Mount - Single Flange Short Standard Linear Bearing

Part No.	Series	Color	A	B	C	D	E	F	G	H	J	K	L	
6715	10	Clear	1.968"	.656"	.250"	.094"	1.624"	1.312"	.306"	.156"	1.312"	.311"	1.875"	
6715-Black	10	Black	1.968"	.656"	.250"	.094"	1.624"	1.312"	.306"	.156"	1.312"	.311"	1.875"	
6815	15	Clear	2.750"	.750"	.375"	.125"	2.505"	2.005"	.493"	.250"	2.000"	.500"	2.812"	
6815-Black	15	Black	2.750"	.750"	.375"	.125"	2.505"	2.005"	.493"	.250"	2.000"	.500"	2.812"	
25-6715	25	Clear	49.73mm	16.48mm	5.99mm	1.80mm	41.12mm	33.15mm	7.80mm	3.99mm	33.25mm	7.98mm	47.00mm	
25-6715-Black	25	Black	49.73mm	16.48mm	5.99mm	1.80mm	41.12mm	33.15mm	7.80mm	3.99mm	33.25mm	7.98mm	47.00mm	
40-6815	40	Clear	71.83mm	19.00mm	8.99mm	2.58mm	65.13mm	52.83mm	12.32mm	6.15mm	52.83mm	11.99mm	75.00mm	
40-6815-Black	40	Black	71.83mm	19.00mm	8.99mm	2.58mm	65.13mm	52.83mm	12.32mm	6.15mm	52.83mm	11.99mm	75.00mm	
			M	N	P	Q	R	S	T	U	V	W	X	Weight
6715	10		.438"	.812"	1.000"	#8 FHSCS		.257"	1.000"	.438"	.343"	.406"	.198 lb	
6715-Black	10		.438"	.812"	1.000"	#8 FHSCS		.257"	1.000"	.438"	.343"	.406"	.198 lb	
6815	15		.656"	1.253"	1.500"	#10 FHSCS		.328"	1.500"	.656"	.375"	.625"	.688 lb	
6815-Black	15		.656"	1.253"	1.500"	#10 FHSCS		.328"	1.500"	.656"	.375"	.625"	.688 lb	
25-6715	25		11.00mm	20.56mm	25.00mm	#8 FHSCS		6.30mm	25.00mm	11.00mm	8.23mm	10.69mm	.0866 kg	
25-6715-Black	25		11.00mm	20.56mm	25.00mm	#8 FHSCS		6.30mm	25.00mm	11.00mm	8.23mm	10.69mm	.0866 kg	
40-6815	40		17.50mm	32.56mm	40.00mm	#10 FHSCS		8.33mm	40.00mm	17.50mm	9.53mm	17.42mm	.3262 kg	
40-6815-Black	40		17.50mm	32.56mm	40.00mm	#10 FHSCS		8.33mm	40.00mm	17.50mm	9.53mm	17.42mm	.3262 kg	

3 Slot Mount - Single Flange Short Standard Linear Bearing with Brake Holes

Part No.	Series	Color	A	B	C	D	E	F	G	H	J	K	L	
6415	10	Clear	1.968"	.656"	.250"	.094"	1.624"	1.312"	.306"	.156"	1.312"	.311"	1.875"	
6415-Black	10	Black	1.968"	.656"	.250"	.094"	1.624"	1.312"	.306"	.156"	1.312"	.311"	1.875"	
6515	15	Clear	2.750"	.750"	.375"	.125"	2.505"	2.005"	.493"	.250"	2.000"	.500"	2.812"	
6515-Black	15	Black	2.750"	.750"	.375"	.125"	2.505"	2.005"	.493"	.250"	2.000"	.500"	2.812"	
25-6415	25	Clear	49.73mm	16.48mm	5.99mm	1.80mm	41.12mm	33.15mm	7.80mm	3.99mm	33.25mm	7.98mm	47.00mm	
25-6415-Black	25	Black	49.73mm	16.48mm	5.99mm	1.80mm	41.12mm	33.15mm	7.80mm	3.99mm	33.25mm	7.98mm	47.00mm	
40-6515	40	Clear	71.83mm	19.00mm	8.99mm	2.58mm	65.13mm	52.83mm	12.32mm	6.15mm	52.83mm	11.99mm	75.00mm	
40-6515-Black	40	Black	71.83mm	19.00mm	8.99mm	2.58mm	65.13mm	52.83mm	12.32mm	6.15mm	52.83mm	11.99mm	75.00mm	
			M	N	P	Q	R	S	T	U	V	W	X	Weight
6415	10		.938"	.438"	.812"	1.000"	#8 FHSCS	.265"	.257"	1.000"	.438"	.343"	.406"	.196 lb
6415-Black	10		.938"	.438"	.812"	1.000"	#8 FHSCS	.265"	.257"	1.000"	.438"	.343"	.406"	.196 lb
6515	15		1.406"	.656"	1.253"	1.500"	#10 FHSCS	.344"	.328"	1.500"	.656"	.375"	.625"	.679 lb
6515-Black	15		1.406"	.656"	1.253"	1.500"	#10 FHSCS	.344"	.328"	1.500"	.656"	.375"	.625"	.679 lb
25-6415	25		23.50mm	11.00mm	20.56mm	25.00mm	#8 FHSCS	6.53mm	6.30mm	25.00mm	11.00mm	8.23mm	10.69mm	.0857 kg
25-6415-Black	25		23.50mm	11.00mm	20.56mm	25.00mm	#8 FHSCS	6.53mm	6.30mm	25.00mm	11.00mm	8.23mm	10.69mm	.0857 kg
40-6515	40		40.00mm	20.00mm	32.56mm	40.00mm	#10 FHSCS	8.71mm	8.33mm	40.00mm	20.00mm	9.53mm	17.42mm	.3253 kg
40-6515-Black	40		40.00mm	20.00mm	32.56mm	40.00mm	#10 FHSCS	8.71mm	8.33mm	40.00mm	20.00mm	9.53mm	17.42mm	.3253 kg

Material Specifications

Material	Alloy*	Process	Finish
Aluminum	6105-T5	Extrude	Anodize

* Or comparable

3 Slot Mount - Single Flange Long Standard Linear Bearing

Part Description:

The 3 slot mount – single flange long standard linear bearing with or without brake holes is typically used in linear motion applications. It houses profiles with a minimum of three open T-slots, has a single flange and is a longer option. The bearing includes pads, screws and shims; the pads are made of self-lubricating UHMW. All 80/20 bearings are designed for compression loads only and not intended to support hanging loads.



Fractional



Metric



Black Anodized

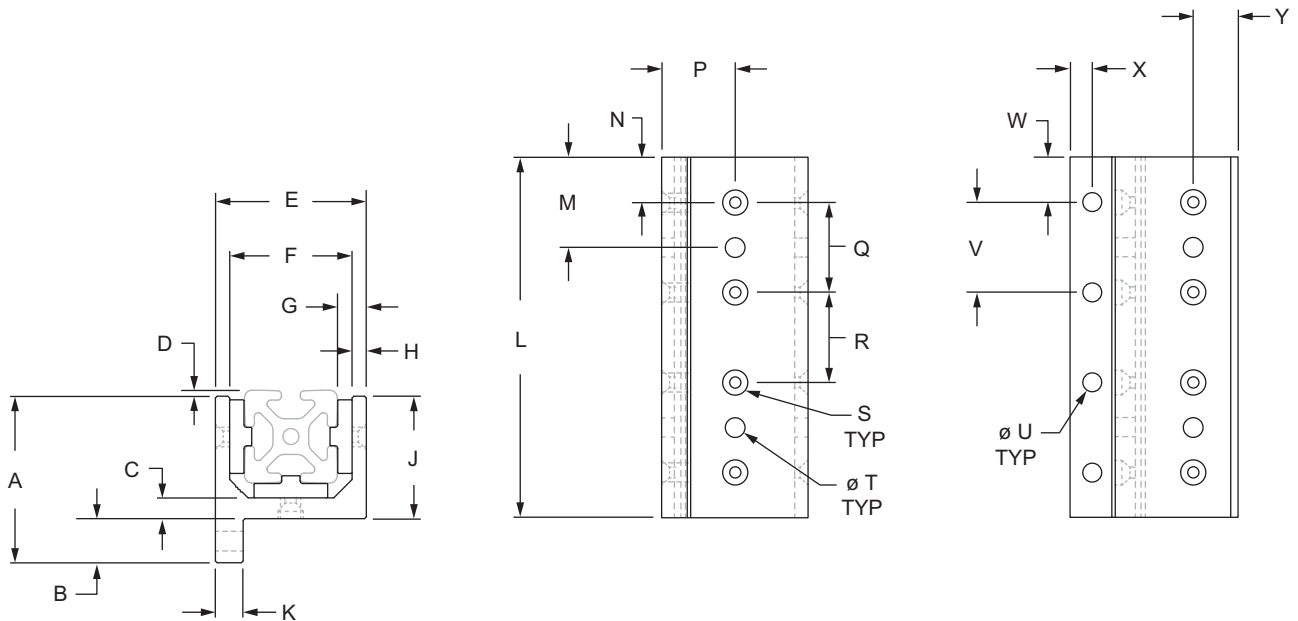

CONTINUE

80/20®
3 Slot Mount - Single Flange Long Standard Linear Bearing (Continued)

3 Slot Mount - Single Flange Long Standard Linear Bearing

Part No.	Series	Color	A	B	C	D	E	F	G	H	J	K	L	M	
6716	10	Clear	1.968"	.656"	.250"	.094"	1.624"	1.312"	.306"	.156"	1.312"	.311"	4.000"	—	
6716-Black	10	Black	1.968"	.656"	.250"	.094"	1.624"	1.312"	.306"	.156"	1.312"	.311"	4.000"		
6816	15	Clear	2.750"	.750"	.375"	.125"	2.505"	2.005"	.493"	.250"	2.000"	.500"	6.000"		
6816-Black	15	Black	2.750"	.750"	.375"	.125"	2.505"	2.005"	.493"	.250"	2.000"	.500"	6.000"		
25-6716	25	Clear	49.73mm	16.48mm	5.99mm	1.80mm	41.12mm	33.15mm	7.80mm	3.99mm	33.25mm	7.98mm	100.00mm		
25-6716-Black	25	Black	49.73mm	16.48mm	5.99mm	1.80mm	41.12mm	33.15mm	7.80mm	3.99mm	33.25mm	7.98mm	100.00mm		
40-6816	40	Clear	71.83mm	19.00mm	8.99mm	2.58mm	65.13mm	52.83mm	12.32mm	6.15mm	52.83mm	11.99mm	160.00mm		
40-6816-Black	40	Black	71.83mm	19.00mm	8.99mm	2.58mm	65.13mm	52.83mm	12.32mm	6.15mm	52.83mm	11.99mm	160.00mm		
			N	P	Q	R	S	T	U	V	W	X	Y		Weight
6716	10	Clear	.500"	.812"	1.000"	1.000"	#8 FHSCS	—	.257"	1.000"	.500"	.343"	.406"		.417 lb
6716-Black	10	Black	.500"	.812"	1.000"	1.000"	#8 FHSCS		.257"	1.000"	.500"	.343"	.406"	.417 lb	
6816	15	Clear	.750"	1.253"	1.500"	1.500"	#10 FHSCS		.328"	1.500"	.656"	.375"	.625"	1.461 lb	
6816-Black	15	Black	.750"	1.253"	1.500"	1.500"	#10 FHSCS		.328"	1.500"	.656"	.375"	.625"	1.461 lb	
25-6716	25	Clear	12.50mm	20.56mm	25.00mm	25.00mm	#8 FHSCS		6.30mm	25.00mm	12.50mm	8.23mm	10.69mm	.190 kg	
25-6716-Black	25	Black	12.50mm	20.56mm	25.00mm	25.00mm	#8 FHSCS		6.30mm	25.00mm	12.50mm	8.23mm	10.69mm	.190 kg	
40-6816	40	Clear	20.00mm	32.56mm	40.00mm	40.00mm	#10 FHSCS		8.33mm	40.00mm	20.00mm	9.53mm	17.42mm	.703 kg	
40-6816-Black	40	Black	20.00mm	32.56mm	40.00mm	40.00mm	#10 FHSCS		8.33mm	40.00mm	20.00mm	9.53mm	17.42mm	.703 kg	

3 Slot Mount - Single Flange Long Standard Linear Bearing with Brake Holes

Part No.	Series	Color	A	B	C	D	E	F	G	H	J	K	L	M
6416	10	Clear	1.968"	.656"	.250"	.094"	1.624"	1.312"	.306"	.156"	1.312"	.311"	4.000"	1.000"
6416-Black	10	Black	1.968"	.656"	.250"	.094"	1.624"	1.312"	.306"	.156"	1.312"	.311"	4.000"	1.000"
6516	15	Clear	2.750"	.750"	.375"	.125"	2.505"	2.005"	.493"	.250"	2.000"	.500"	6.000"	1.500"
6516-Black	15	Black	2.750"	.750"	.375"	.125"	2.505"	2.005"	.493"	.250"	2.000"	.500"	6.000"	1.500"
25-6416	25	Clear	49.73mm	16.48mm	5.99mm	1.80mm	41.12mm	33.15mm	7.80mm	3.99mm	33.25mm	7.98mm	100.00mm	25.00mm
25-6416-Black	25	Black	49.73mm	16.48mm	5.99mm	1.80mm	41.12mm	33.15mm	7.80mm	3.99mm	33.25mm	7.98mm	100.00mm	25.00mm
40-6516	40	Clear	71.83mm	19.00mm	8.99mm	2.58mm	65.13mm	52.83mm	12.32mm	6.15mm	52.83mm	11.99mm	160.00mm	40.00mm
40-6516-Black	40	Black	71.83mm	19.00mm	8.99mm	2.58mm	65.13mm	52.83mm	12.32mm	6.15mm	52.83mm	11.99mm	160.00mm	40.00mm
			N	P	Q	R	S	T	U	V	W	X	Y	Weight
6416	10	Clear	.500"	.812"	1.000"	1.000"	#8 FHSCS	.265"	.257"	1.000"	.500"	.343"	.406"	.414 lb
6416-Black	10	Black	.500"	.812"	1.000"	1.000"	#8 FHSCS	.265"	.257"	1.000"	.500"	.343"	.406"	.414 lb
6516	15	Clear	.750"	1.253"	1.500"	1.500"	#10 FHSCS	.344"	.328"	1.500"	.656"	.375"	.625"	1.443 lb
6516-Black	15	Black	.750"	1.253"	1.500"	1.500"	#10 FHSCS	.344"	.328"	1.500"	.656"	.375"	.625"	1.443 lb
25-6416	25	Clear	12.50mm	20.56mm	25.00mm	25.00mm	#8 FHSCS	6.53mm	6.30mm	25.00mm	12.50mm	8.23mm	10.69mm	.190 kg
25-6416-Black	25	Black	12.50mm	20.56mm	25.00mm	25.00mm	#8 FHSCS	6.53mm	6.30mm	25.00mm	12.50mm	8.23mm	10.69mm	.190 kg
40-6516	40	Clear	20.00mm	32.56mm	40.00mm	40.00mm	#10 FHSCS	8.71mm	8.33mm	40.00mm	20.00mm	9.53mm	17.42mm	.695 kg
40-6516-Black	40	Black	20.00mm	32.56mm	40.00mm	40.00mm	#10 FHSCS	8.71mm	8.33mm	40.00mm	20.00mm	9.53mm	17.42mm	.695 kg

Material Specifications

Material	Alloy*	Process	Finish
Aluminum	6105-T5	Extrude	Anodize

* Or comparable

3 Slot Mount - Double Flange Short Standard Linear Bearing

Part Description:

The 3 slot mount – double flange short standard linear bearing with or without brake holes is typically used in linear motion applications. It houses profiles with a minimum of three open T-slots, has a double flange and is a shorter option. The bearing includes pads, screws and shims; the pads are made of self-lubricating UHMW. All 80/20 bearings are designed for compression loads only and not intended to support hanging loads.



Fractional



Metric



Black Anodized

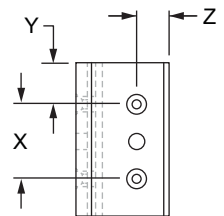
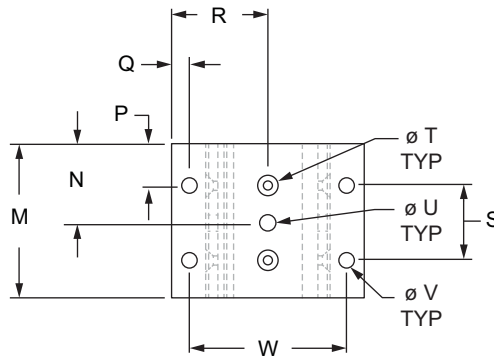
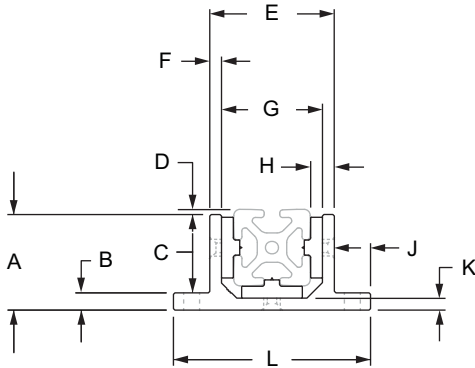

CONTINUE

3 Slot Mount - Double Flange Short Standard Linear Bearing (Continued)

3 Slot Mount - Double Flange Short Standard Linear Bearing

Part No.	Series	Color	A	B	C	D	E	F	G	H	J	K	L	M
6725	10	Clear	1.218"	.312"	.906"	.094"	1.624"	.156"	1.312"	.306"	.656"	.156"	2.936"	1.875"
6725-Black	10	Black	1.218"	.312"	.906"	.094"	1.624"	.156"	1.312"	.306"	.656"	.156"	2.936"	1.875"
6825	15	Clear	1.875"	.375"	1.500"	.125"	2.505"	.250"	2.005"	.493"	.748"	.250"	4.000"	2.812"
6825-Black	15	Black	1.875"	.375"	1.500"	.125"	2.505"	.250"	2.005"	.493"	.748"	.250"	4.000"	2.812"
25-6725	25	Clear	31.20mm	8.00mm	23.20mm	1.80mm	41.15mm	4.00mm	33.15mm	7.80mm	16.47mm	4.00mm	74.09mm	47.00mm
25-6725-Black	25	Black	31.20mm	8.00mm	23.20mm	1.80mm	41.15mm	4.00mm	33.15mm	7.80mm	16.47mm	4.00mm	74.09mm	47.00mm
40-6825	40	Clear	50.00mm	9.00mm	41.00mm	2.58mm	65.12mm	6.15mm	52.82mm	12.32mm	19.00mm	6.15mm	103.12mm	75.00mm
40-6825-Black	40	Black	50.00mm	9.00mm	41.00mm	2.58mm	65.12mm	6.15mm	52.82mm	12.32mm	19.00mm	6.15mm	103.12mm	75.00mm
		N	P	Q	R	S	T	U	V	W	X	Y	Z	Weight
6725	10		.438"	.343"	1.468"	1.000"	#8 FHSCS		.257"	2.250"	1.000"	.438"	.406"	.207 lb
6725-Black	10		.438"	.343"	1.468"	1.000"	#8 FHSCS		.257"	2.250"	1.000"	.438"	.406"	.207 lb
6825	15		.656"	.375"	2.000"	1.500"	#10 FHSCS		.328"	3.250"	1.500"	.656"	.625"	.655 lb
6825-Black	15		.656"	.375"	2.000"	1.500"	#10 FHSCS		.328"	3.250"	1.500"	.656"	.625"	.655 lb
25-6725	25		11.00mm	8.48mm	37.05mm	25.00mm	#8 FHSCS		6.30mm	57.12mm	25.00mm	11.00mm	10.64mm	.0929 kg
25-6725-Black	25		11.00mm	8.48mm	37.05mm	25.00mm	#8 FHSCS		6.30mm	57.12mm	25.00mm	11.00mm	10.64mm	.0929 kg
40-6825	40		17.50mm	9.50mm	51.56mm	40.00mm	#10 FHSCS		8.33mm	84.12mm	40.00mm	17.50mm	17.42mm	.3137 kg
40-6825-Black	40		17.50mm	9.50mm	51.56mm	40.00mm	#10 FHSCS		8.33mm	84.12mm	40.00mm	17.50mm	17.42mm	.31375 kg

3 Slot Mount - Double Flange Short Standard Linear Bearing with Brake Holes

Part No.	Series	Color	A	B	C	D	E	F	G	H	J	K	L	M	
6425	10	Clear	1.218"	.312"	.906"	.094"	1.624"	.156"	1.312"	.306"	.656"	.156"	2.936"	1.875"	
6425-Black	10	Black	1.218"	.312"	.906"	.094"	1.624"	.156"	1.312"	.306"	.656"	.156"	2.936"	1.875"	
6525	15	Clear	1.875"	.375"	1.500"	.125"	2.505"	.250"	2.005"	.493"	.748"	.250"	4.000"	2.812"	
6525-Black	15	Black	1.875"	.375"	1.500"	.125"	2.505"	.250"	2.005"	.493"	.748"	.250"	4.000"	2.812"	
25-6425	25	Clear	31.20mm	8.00mm	23.20mm	1.80mm	41.15mm	4.00mm	33.15mm	7.80mm	16.47mm	4.00mm	74.09mm	47.00mm	
25-6425-Black	25	Black	31.20mm	8.00mm	23.20mm	1.80mm	41.15mm	4.00mm	33.15mm	7.80mm	16.47mm	4.00mm	74.09mm	47.00mm	
40-6525	40	Clear	50.00mm	9.00mm	41.00mm	2.58mm	65.12mm	6.15mm	52.82mm	12.32mm	19.00mm	6.15mm	103.12mm	75.00mm	
40-6525-Black	40	Black	50.00mm	9.00mm	41.00mm	2.58mm	65.12mm	6.15mm	52.82mm	12.32mm	19.00mm	6.15mm	103.12mm	75.00mm	
		N	P	Q	R	S	T	U	V	W	X	Y	Z	Weight	
6425	10		.938"	.438"	.343"	1.468"	1.000"	#8 FHSCS	.265"	.257"	2.250"	1.000"	.438"	.406"	.205 lb
6425-Black	10		.938"	.438"	.343"	1.468"	1.000"	#8 FHSCS	.265"	.257"	2.250"	1.000"	.438"	.406"	.205 lb
6525	15		1.406"	.656"	.375"	2.000"	1.500"	#10 FHSCS	.344"	.328"	3.250"	1.500"	.656"	.625"	.653 lb
6525-Black	15		1.406"	.656"	.375"	2.000"	1.500"	#10 FHSCS	.344"	.328"	3.250"	1.500"	.656"	.625"	.653 lb
25-6425	25		23.50mm	11.00mm	8.48mm	37.05mm	25.00mm	#8 FHSCS	6.53mm	6.30mm	57.12mm	25.00mm	11.00mm	10.64mm	.0916 kg
25-6425-Black	25		23.50mm	11.00mm	8.48mm	37.05mm	25.00mm	#8 FHSCS	6.53mm	6.30mm	57.12mm	25.00mm	11.00mm	10.64mm	.0916 kg
40-6525	40		37.50mm	17.50mm	9.50mm	51.56mm	40.00mm	#10 FHSCS	8.71mm	8.33mm	84.12mm	40.00mm	17.50mm	17.42mm	.3116 kg
40-6525-Black	40		37.50mm	17.50mm	9.50mm	51.56mm	40.00mm	#10 FHSCS	8.71mm	8.33mm	84.12mm	40.00mm	17.50mm	17.42mm	.3116 kg

Material Specifications

Material	Alloy*	Process	Finish
Aluminum	6105-T5	Extrude	Anodize

* Or comparable

3 Slot Mount - Double Flange Long Standard Linear Bearing

Part Description:

The 3 slot mount – double flange long standard linear bearing with or without brake holes is typically used in linear motion applications. It houses profiles with a minimum of three open T-slots, has a double flange and is a longer option. The bearing includes pads, screws and shims; the pads are made of self-lubricating UHMW. All 80/20 bearings are designed for compression loads only and not intended to support hanging loads.



Fractional



Metric



Black Anodized

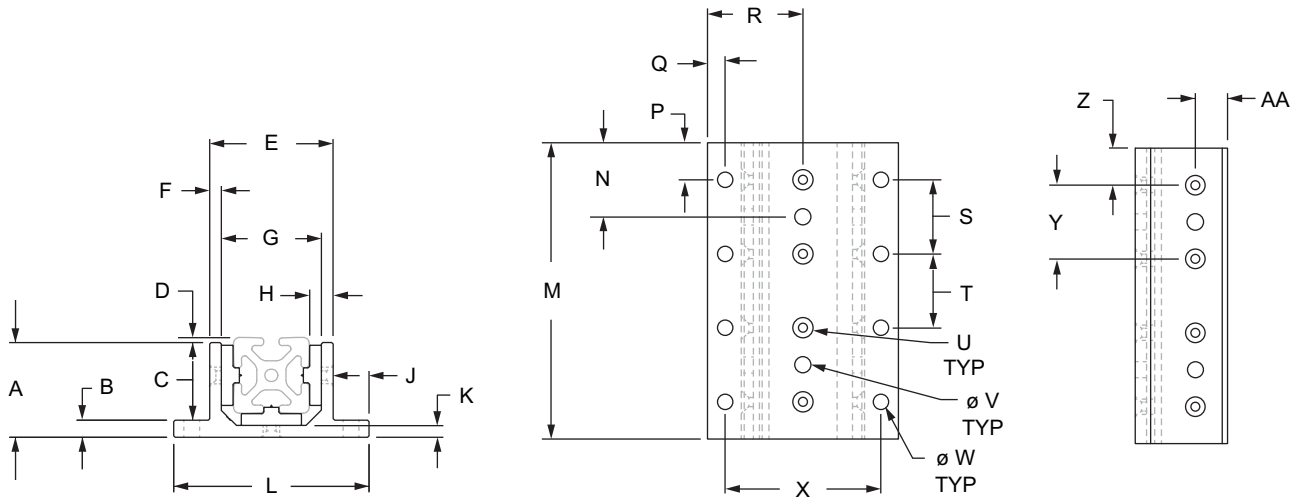

CONTINUE

3 Slot Mount - Double Flange Long Standard Linear Bearing (Continued)

3 Slot Mount - Double Flange Long Standard Linear Bearing

Part No.	Series	Color	A	B	C	D	E	F	G	H	J	K	L	M	N	
6726	10	Clear	1.218"	.312"	.906"	.094"	1.624"	.156"	1.312"	.306"	.656"	.156"	2.936"	4.000"	—	
6726-Black	10	Black	1.218"	.312"	.906"	.094"	1.624"	.156"	1.312"	.306"	.656"	.156"	2.936"	4.000"		
6826	15	Clear	1.875"	.375"	1.500"	.125"	2.505"	.250"	2.005"	.493"	.748"	.250"	4.000"	6.000"		
6826-Black	15	Black	1.875"	.375"	1.500"	.125"	2.505"	.250"	2.005"	.493"	.748"	.250"	4.000"	6.000"		
25-6726	25	Clear	31.20mm	8.00mm	23.20mm	1.80mm	41.15mm	4.00mm	33.15mm	7.80mm	16.47mm	4.00mm	74.09mm	100.00mm		
25-6726-Black	25	Black	31.20mm	8.00mm	23.20mm	1.80mm	41.15mm	4.00mm	33.15mm	7.80mm	16.47mm	4.00mm	74.09mm	100.00mm		
40-6826	40	Clear	50.00mm	9.00mm	41.00mm	2.58mm	65.12mm	6.15mm	52.82mm	12.32mm	19.00mm	6.15mm	103.12mm	160.00mm		
40-6826-Black	40	Black	50.00mm	9.00mm	41.00mm	2.58mm	65.12mm	6.15mm	52.82mm	12.32mm	19.00mm	6.15mm	103.12mm	160.00mm		
			P	Q	R	S	T	U	V	W	X	Y	Z	AA		Weight
6726	10	Clear	.500"	.343"	1.468"	1.000"	1.000"	#8 FHSCS	—	.257"	2.250"	1.000"	.500"	.406"		.437 lb
6726-Black	10	Black	.500"	.343"	1.468"	1.000"	1.000"	#8 FHSCS		.257"	2.250"	1.000"	.500"	.406"	.437 lb	
6826	15	Clear	.750"	.375"	2.000"	1.500"	1.500"	#10 FHSCS		.328"	3.250"	1.500"	.750"	.625"	1.394 lb	
6826-Black	15	Black	.750"	.375"	2.000"	1.500"	1.500"	#10 FHSCS		.328"	3.250"	1.500"	.750"	.625"	1.394 lb	
25-6726	25	Clear	12.50mm	8.48mm	37.05mm	25.00mm	25.00mm	#8 FHSCS		6.30mm	57.12mm	25.00mm	12.50mm	10.64mm	.2028 kg	
25-6726-Black	25	Black	12.50mm	8.48mm	37.05mm	25.00mm	25.00mm	#8 FHSCS		6.30mm	57.12mm	25.00mm	12.50mm	10.64mm	.2028 kg	
40-6826	40	Clear	20.00mm	9.50mm	51.56mm	40.00mm	40.00mm	#10 FHSCS		8.33mm	84.12mm	40.00mm	20.00mm	17.42mm	.6651 kg	
40-6826-Black	40	Black	20.00mm	9.50mm	51.56mm	40.00mm	40.00mm	#10 FHSCS		8.33mm	84.12mm	40.00mm	20.00mm	17.42mm	.6651 kg	

3 Slot Mount - Double Flange Long Standard Linear Bearing with Brake Holes

Part No.	Series	Color	A	B	C	D	E	F	G	H	J	K	L	M	N
6426	10	Clear	1.218"	.312"	.906"	.094"	1.624"	.156"	1.312"	.306"	.656"	.156"	2.936"	4.000"	1.000"
6426-Black	10	Black	1.218"	.312"	.906"	.094"	1.624"	.156"	1.312"	.306"	.656"	.156"	2.936"	4.000"	1.000"
6526	15	Clear	1.875"	.375"	1.500"	.125"	2.505"	.250"	2.005"	.493"	.748"	.250"	4.000"	6.000"	1.500"
6526-Black	15	Black	1.875"	.375"	1.500"	.125"	2.505"	.250"	2.005"	.493"	.748"	.250"	4.000"	6.000"	1.500"
25-6426	25	Clear	31.20mm	8.00mm	23.20mm	1.80mm	41.15mm	4.00mm	33.15mm	7.80mm	16.47mm	4.00mm	74.09mm	100.00mm	25.00mm
25-6426-Black	25	Black	31.20mm	8.00mm	23.20mm	1.80mm	41.15mm	4.00mm	33.15mm	7.80mm	16.47mm	4.00mm	74.09mm	100.00mm	25.00mm
40-6526	40	Clear	50.00mm	9.00mm	41.00mm	2.58mm	65.12mm	6.15mm	52.82mm	12.32mm	19.00mm	6.15mm	103.12mm	160.00mm	40.00mm
40-6526-Black	40	Black	50.00mm	9.00mm	41.00mm	2.58mm	65.12mm	6.15mm	52.82mm	12.32mm	19.00mm	6.15mm	103.12mm	160.00mm	40.00mm
			P	Q	R	S	T	U	V	W	X	Y	Z	AA	Weight
6426	10	Clear	.500"	.343"	1.468"	1.000"	1.000"	#8 FHSCS	.265"	.257"	2.250"	1.000"	.500"	.406"	.433 lb
6426-Black	10	Black	.500"	.343"	1.468"	1.000"	1.000"	#8 FHSCS	.265"	.257"	2.250"	1.000"	.500"	.406"	.433 lb
6526	15	Clear	.750"	.375"	2.000"	1.500"	1.500"	#10 FHSCS	.344"	.328"	3.250"	1.500"	.750"	.625"	1.379 lb
6526-Black	15	Black	.750"	.375"	2.000"	1.500"	1.500"	#10 FHSCS	.344"	.328"	3.250"	1.500"	.750"	.625"	1.379 lb
25-6426	25	Clear	12.50mm	8.48mm	37.05mm	25.00mm	25.00mm	#8 FHSCS	6.53mm	6.30mm	57.12mm	25.00mm	12.50mm	10.64mm	.1972 kg
25-6426-Black	25	Black	12.50mm	8.48mm	37.05mm	25.00mm	25.00mm	#8 FHSCS	6.53mm	6.30mm	57.12mm	25.00mm	12.50mm	10.64mm	.1972 kg
40-6526	40	Clear	20.00mm	9.50mm	51.56mm	40.00mm	40.00mm	#10 FHSCS	8.71mm	8.33mm	84.12mm	40.00mm	20.00mm	17.42mm	.6650 kg
40-6526-Black	40	Black	20.00mm	9.50mm	51.56mm	40.00mm	40.00mm	#10 FHSCS	8.71mm	8.33mm	84.12mm	40.00mm	20.00mm	17.42mm	.6650 kg

Material Specifications

Material	Alloy*	Process	Finish
Aluminum	6105-T5	Extrude	Anodize

* Or comparable

4 Slot Mount - Double Flange Short Standard Linear Bearing

Part Description:

The 4 slot mount – double flange short standard linear bearing with or without brake holes is typically used in linear motion applications. It houses profiles with a minimum of four open T-slots, has a double flange and is a shorter option. The bearing includes pads, screws and shims; the pads are made of self-lubricating UHMW. All 80/20 bearings are designed for compression loads only and not intended to support hanging loads.



Fractional



Metric



Black Anodized

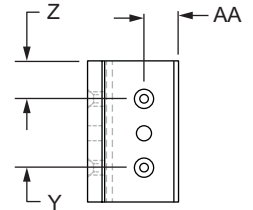
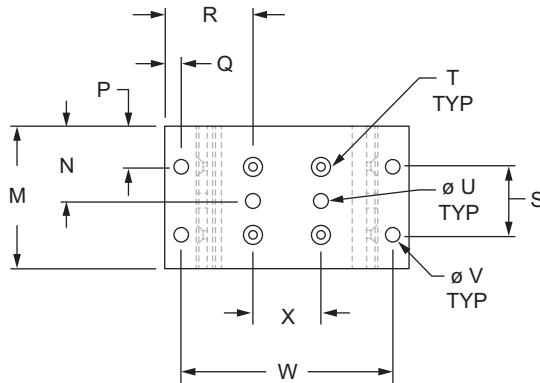
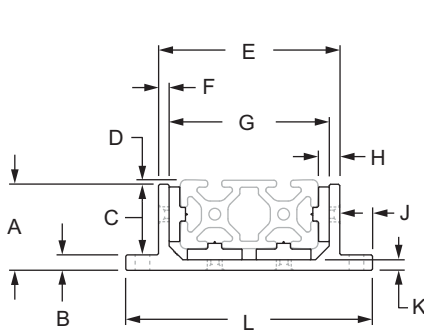

CONTINUE

4 Slot Mount - Double Flange Short Standard Linear Bearing (Continued)

4 Slot Mount - Double Flange Short Standard Linear Bearing

Part No.	Series	Color	A	B	C	D	E	F	G	H	J	K	L	M	N
6723	10	Clear	1.218"	.312"	.906"	.094"	2.630"	.156"	2.318"	.306"	.654"	.156"	3.938"	1.875"	
6723-Black	10	Black	1.218"	.312"	.906"	.094"	2.630"	.156"	2.318"	.306"	.654"	.156"	3.938"	1.875"	
6823	15	Clear	1.875"	.375"	1.500"	.125"	4.005"	.250"	3.505"	.493"	.748"	.250"	5.500"	2.812"	
6823-Black	15	Black	1.875"	.375"	1.500"	.125"	4.005"	.250"	3.505"	.493"	.748"	.250"	5.500"	2.812"	
25-6723	25	Clear	31.24mm	8.00mm	23.24mm	1.80mm	66.29mm	3.99mm	58.32mm	7.80mm	16.48mm	3.99mm	99.26mm	47.00mm	
25-6723-Black	25	Black	31.24mm	8.00mm	23.24mm	1.80mm	66.29mm	3.99mm	58.32mm	7.80mm	16.48mm	3.99mm	99.26mm	47.00mm	
40-6823	40	Clear	50.00mm	9.00mm	41.00mm	2.58mm	105.31mm	6.15mm	93.01mm	12.32mm	19.00mm	6.15mm	143.31mm	75.00mm	
40-6823-Black	40	Black	50.00mm	9.00mm	41.00mm	2.58mm	105.31mm	6.15mm	93.01mm	12.32mm	19.00mm	6.15mm	143.31mm	75.00mm	
			P	Q	R	S	T	U	V	W	X	Y	Z	AA	Weight
6723	10	Clear	.438"	1.469"	.344"	1.000"	#8 FHSCS		.257"	3.250"	1.000"	1.000"	.438"	.406"	.247 lb
6723-Black	10	Black	.438"	1.469"	.344"	1.000"	#8 FHSCS		.257"	3.250"	1.000"	1.000"	.438"	.406"	.247 lb
6823	15	Clear	.656"	2.000"	.375"	1.500"	#10 FHSCS		.328"	4.750"	1.500"	1.500"	.656"	.625"	.797 lb
6823-Black	15	Black	.656"	2.000"	.375"	1.500"	#10 FHSCS		.328"	4.750"	1.500"	1.500"	.656"	.625"	.797 lb
25-6723	25	Clear	11.00mm	37.13mm	8.48mm	25.00mm	#8 FHSCS		6.53mm	82.23mm	25.00mm	25.00mm	11.00mm	10.69mm	.1154 kg
25-6723-Black	25	Black	11.00mm	37.13mm	8.48mm	25.00mm	#8 FHSCS		6.53mm	82.23mm	25.00mm	25.00mm	11.00mm	10.69mm	.1154 kg
40-6823	40	Clear	17.50mm	51.66mm	9.50mm	40.00mm	#10 FHSCS		8.33mm	124.31mm	40.00mm	40.00mm	17.50mm	17.42mm	.3792 kg
40-6823-Black	40	Black	17.50mm	51.66mm	9.50mm	40.00mm	#10 FHSCS		8.33mm	124.31mm	40.00mm	40.00mm	17.50mm	17.42mm	.3792 kg

4 Slot Mount - Double Flange Short Standard Linear Bearing with Brake Holes

Part No.	Series	Color	A	B	C	D	E	F	G	H	J	K	L	M	N
6423	10	Clear	1.218"	.312"	.906"	.094"	2.630"	.156"	2.318"	.306"	.654"	.156"	3.938"	1.875"	.938"
6423-Black	10	Black	1.218"	.312"	.906"	.094"	2.630"	.156"	2.318"	.306"	.654"	.156"	3.938"	1.875"	.938"
6523	15	Clear	1.875"	.375"	1.500"	.125"	4.005"	.250"	3.505"	.493"	.748"	.250"	5.500"	2.812"	1.406"
6523-Black	15	Black	1.875"	.375"	1.500"	.125"	4.005"	.250"	3.505"	.493"	.748"	.250"	5.500"	2.812"	1.406"
25-6423	25	Clear	31.24mm	8.00mm	23.24mm	1.80mm	66.29mm	3.99mm	58.32mm	7.80mm	16.48mm	3.99mm	99.26mm	47.00mm	23.50mm
25-6423-Black	25	Black	31.24mm	8.00mm	23.24mm	1.80mm	66.29mm	3.99mm	58.32mm	7.80mm	16.48mm	3.99mm	99.26mm	47.00mm	23.50mm
40-6523	40	Clear	50.00mm	9.00mm	41.00mm	2.58mm	105.31mm	6.15mm	93.01mm	12.32mm	19.00mm	6.15mm	143.31mm	75.00mm	37.50mm
40-6523-Black	40	Black	50.00mm	9.00mm	41.00mm	2.58mm	105.31mm	6.15mm	93.01mm	12.32mm	19.00mm	6.15mm	143.31mm	75.00mm	37.50mm
			P	Q	R	S	T	U	V	W	X	Y	Z	AA	Weight
6423	10	Clear	.438"	1.469"	.344"	1.000"	#8 FHSCS	.265"	.257"	3.250"	1.000"	1.000"	.438"	.406"	.244 lb
6423-Black	10	Black	.438"	1.469"	.344"	1.000"	#8 FHSCS	.265"	.257"	3.250"	1.000"	1.000"	.438"	.406"	.244 lb
6523	15	Clear	.656"	2.000"	.375"	1.500"	#10 FHSCS	.343"	.328"	4.750"	1.500"	1.500"	.656"	.625"	.785 lb
6523-Black	15	Black	.656"	2.000"	.375"	1.500"	#10 FHSCS	.343"	.328"	4.750"	1.500"	1.500"	.656"	.625"	.785 lb
25-6423	25	Clear	11.00mm	37.13mm	8.48mm	25.00mm	#8 FHSCS	6.53mm	6.53mm	82.23mm	25.00mm	25.00mm	11.00mm	10.69mm	.1076 kg
25-6423-Black	25	Black	11.00mm	37.13mm	8.48mm	25.00mm	#8 FHSCS	6.53mm	6.53mm	82.23mm	25.00mm	25.00mm	11.00mm	10.69mm	.1076 kg
40-6523	40	Clear	17.50mm	51.66mm	9.50mm	40.00mm	#10 FHSCS	8.71mm	8.33mm	124.31mm	40.00mm	40.00mm	17.50mm	17.42mm	.3702 kg
40-6523-Black	40	Black	17.50mm	51.66mm	9.50mm	40.00mm	#10 FHSCS	8.71mm	8.33mm	124.31mm	40.00mm	40.00mm	17.50mm	17.42mm	.3702 kg

Material Specifications

Material	Alloy*	Process	Finish
Aluminum	6105-T5	Extrude	Anodize

* Or comparable

4 Slot Mount - Double Flange Long Standard Linear Bearing

Part Description:

The 4 slot mount – double flange long standard linear bearing with or without brake holes is typically used in linear motion applications. It houses profiles with a minimum of four open T-slots, has a double flange and is a longer option. The bearing includes pads, screws and shims; the pads are made of self-lubricating UHMW. All 80/20 bearings are designed for compression loads only and not intended to support hanging loads.



Fractional



Metric



Black Anodized

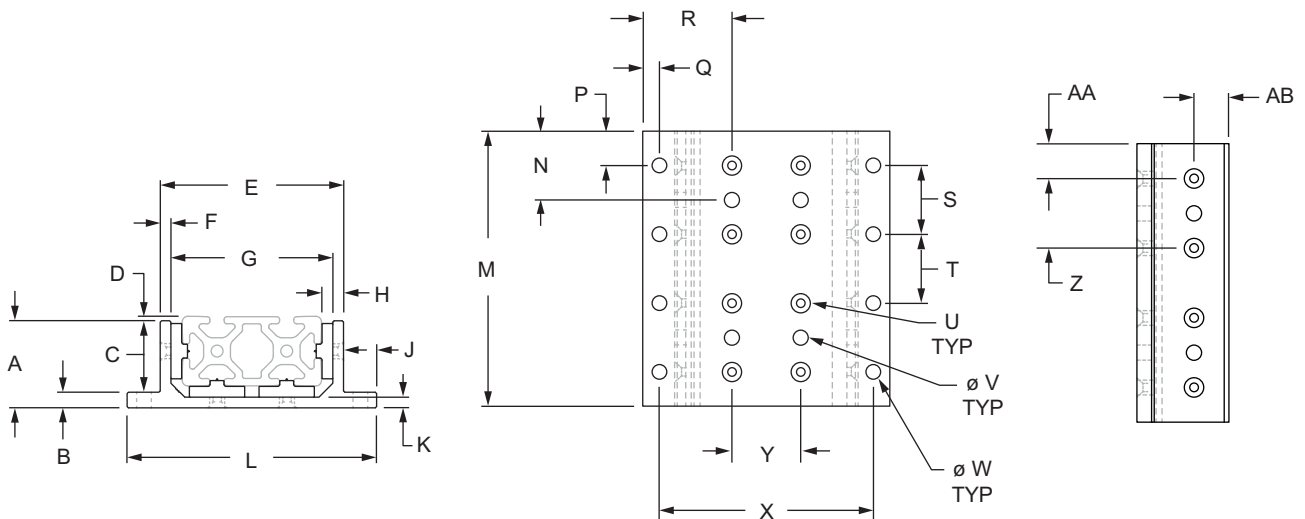

CONTINUE

4 Slot Mount - Double Flange Long Standard Linear Bearing (Continued)

4 Slot Mount - Double Flange Long Standard Linear Bearing

Part No.	Series	Color	A	B	C	D	E	F	G	H	J	K	L	M	N	
6724	10	Clear	1.218"	.312"	.906"	.094"	2.630"	.156"	2.318"	.306"	.654"	.156"	3.938"	4.000"	—	
6724-Black	10	Black	1.218"	.312"	.906"	.094"	2.630"	.156"	2.318"	.306"	.654"	.156"	3.938"	4.000"		
6824	15	Clear	1.875"	.375"	1.500"	.125"	4.005"	.250"	3.505"	.493"	.748"	.250"	5.500"	6.000"		
6824-Black	15	Black	1.875"	.375"	1.500"	.125"	4.005"	.250"	3.505"	.493"	.748"	.250"	5.500"	6.000"		
25-6724	25	Clear	31.24mm	8.00mm	23.24mm	1.80mm	66.29mm	3.99mm	58.32mm	7.80mm	16.48mm	3.99mm	99.26mm	100.00mm		
25-6724-Black	25	Black	31.24mm	8.00mm	23.24mm	1.80mm	66.29mm	3.99mm	58.32mm	7.80mm	16.48mm	3.99mm	99.26mm	100.00mm		
40-6824	40	Clear	50.00mm	9.00mm	41.00mm	2.58mm	105.31mm	6.15mm	93.01mm	12.32mm	19.00mm	6.15mm	143.31mm	160.00mm		
40-6824-Black	40	Black	50.00mm	9.00mm	41.00mm	2.58mm	105.31mm	6.15mm	93.01mm	12.32mm	19.00mm	6.15mm	143.31mm	160.00mm		
			P	Q	R	S	T	U	V	W	X	Y	Z	AA	AB	Weight
6724	10	.500"	1.469"	.344"	1.000"	1.000"	#8 FHSCS	—	.257"	3.250"	1.000"	1.000"	.500"	.406"	.519 lb	
6724-Black	10	.500"	1.469"	.344"	1.000"	1.000"	#8 FHSCS		.257"	3.250"	1.000"	1.000"	.500"	.406"	.519 lb	
6824	15	.750"	2.000"	.375"	1.500"	1.500"	#10 FHSCS		.328"	4.750"	1.500"	1.500"	.750"	.625"	1.691 lb	
6824-Black	15	.750"	2.000"	.375"	1.500"	1.500"	#10 FHSCS		.328"	4.750"	1.500"	1.500"	.750"	.625"	1.691 lb	
25-6724	25	12.50mm	37.13mm	8.48mm	25.00mm	25.00mm	#8 FHSCS		6.53mm	82.23mm	25.00mm	25.00mm	12.50mm	10.69mm	.2393 kg	
25-6724-Black	25	12.50mm	37.13mm	8.48mm	25.00mm	25.00mm	#8 FHSCS		6.53mm	82.23mm	25.00mm	25.00mm	12.50mm	10.69mm	.2393 kg	
40-6824	40	20.00mm	51.66mm	9.50mm	40.00mm	40.00mm	#10 FHSCS		8.33mm	124.31mm	40.00mm	40.00mm	20.00mm	17.42mm	.7938 kg	
40-6824-Black	40	20.00mm	51.66mm	9.50mm	40.00mm	40.00mm	#10 FHSCS		8.33mm	124.31mm	40.00mm	40.00mm	20.00mm	17.42mm	.7938 kg	

4 Slot Mount - Double Flange Long Standard Linear Bearing with Brake Holes

Part No.	Series	Color	A	B	C	D	E	F	G	H	J	K	L	M	N	
6424	10	Clear	1.218"	.312"	.906"	.094"	2.630"	.156"	2.318"	.306"	.654"	.156"	3.938"	4.000"	1.000"	
6424-Black	10	Black	1.218"	.312"	.906"	.094"	2.630"	.156"	2.318"	.306"	.654"	.156"	3.938"	4.000"	1.000"	
6524	15	Clear	1.875"	.375"	1.500"	.125"	4.005"	.250"	3.505"	.493"	.748"	.250"	5.500"	6.000"	1.500"	
6524-Black	15	Black	1.875"	.375"	1.500"	.125"	4.005"	.250"	3.505"	.493"	.748"	.250"	5.500"	6.000"	1.500"	
25-6424	25	Clear	31.24mm	8.00mm	23.24mm	1.80mm	66.29mm	3.99mm	58.32mm	7.80mm	16.48mm	3.99mm	99.26mm	100.00mm	25.00mm	
25-6424-Black	25	Black	31.24mm	8.00mm	23.24mm	1.80mm	66.29mm	3.99mm	58.32mm	7.80mm	16.48mm	3.99mm	99.26mm	100.00mm	25.00mm	
40-6524	40	Clear	50.00mm	9.00mm	41.00mm	2.58mm	105.31mm	6.15mm	93.01mm	12.32mm	19.00mm	6.15mm	143.31mm	160.00mm	40.00mm	
40-6524-Black	40	Black	50.00mm	9.00mm	41.00mm	2.58mm	105.31mm	6.15mm	93.01mm	12.32mm	19.00mm	6.15mm	143.31mm	160.00mm	40.00mm	
			P	Q	R	S	T	U	V	W	X	Y	Z	AA	AB	Weight
6424	10	.500"	1.469"	.344"	1.000"	1.000"	#8 FHSCS	.265"	.257"	3.250"	1.000"	1.000"	.500"	.406"	.515 lb	
6424-Black	10	.500"	1.469"	.344"	1.000"	1.000"	#8 FHSCS	.265"	.257"	3.250"	1.000"	1.000"	.500"	.406"	.515 lb	
6524	15	.750"	2.000"	.375"	1.500"	1.500"	#10 FHSCS	.343"	.328"	4.750"	1.500"	1.500"	.750"	.625"	1.668 lb	
6524-Black	15	.750"	2.000"	.375"	1.500"	1.500"	#10 FHSCS	.343"	.328"	4.750"	1.500"	1.500"	.750"	.625"	1.668 lb	
25-6424	25	12.50mm	37.13mm	8.48mm	25.00mm	25.00mm	#8 FHSCS	6.53mm	6.53mm	82.23mm	25.00mm	25.00mm	12.50mm	10.69mm	.2265 kg	
25-6424-Black	25	12.50mm	37.13mm	8.48mm	25.00mm	25.00mm	#8 FHSCS	6.53mm	6.53mm	82.23mm	25.00mm	25.00mm	12.50mm	10.69mm	.2265 kg	
40-6524	40	20.00mm	51.66mm	9.50mm	40.00mm	40.00mm	#10 FHSCS	8.71mm	8.33mm	124.31mm	40.00mm	40.00mm	20.00mm	17.42mm	.7879 kg	
40-6524-Black	40	20.00mm	51.66mm	9.50mm	40.00mm	40.00mm	#10 FHSCS	8.71mm	8.33mm	124.31mm	40.00mm	40.00mm	20.00mm	17.42mm	.7879 kg	

Material Specifications

Material	Alloy*	Process	Finish
Aluminum	6105-T5	Extrude	Anodize

* Or comparable

3 Slot Mount - Single Flange Short High-Cycle Linear Bearing

Part Description:

The 3 slot mount – single flange short high-cycle linear bearing is typically used in linear motion applications. It contains special threaded inserts in the pads which provide a heavy-duty bearing, with or without holes, capable of withstanding repetitive cycles with sudden acceleration and deceleration. The bearing houses profiles with a minimum of three open T-slots, has a single flange and is a shorter option. The pads, screws and shims are included; the pads are made of self-lubricating UHMW. All 80/20 bearings are designed for compression loads only and not intended to support hanging loads.



Fractional



Metric



Black Anodized

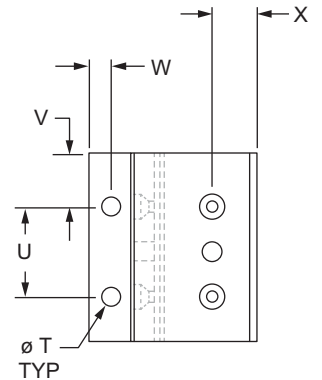
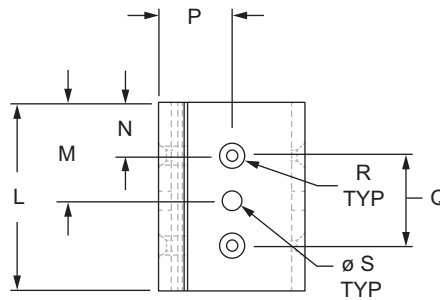
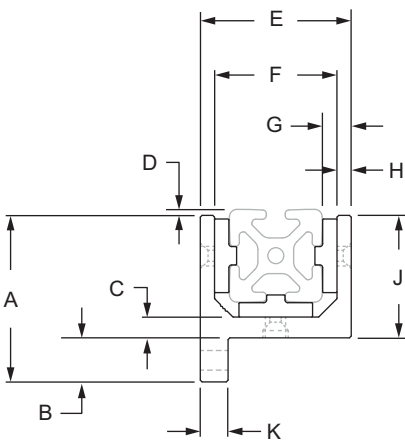

CONTINUE

80/20[®] 3 Slot Mount - Single Flange Short High-Cycle Linear Bearing (Continued)

3 Slot Mount - Single Flange Short High-Cycle Linear Bearing

Part No.	Series	Color	A	B	C	D	E	F	G	H	J	K	L	
6830	15	Clear	2.750"	.750"	.375"	.125"	2.505"	2.005"	.493"	.250"	2.000"	.500"	2.812"	
6830-Black	15	Black	2.750"	.750"	.375"	.125"	2.505"	2.005"	.493"	.250"	2.000"	.500"	2.812"	
40-6830	40	Clear	71.83mm	19.00mm	8.99mm	2.58mm	65.13mm	52.83mm	12.32mm	6.15mm	52.83mm	11.99mm	75.00mm	
40-6830-Black	40	Black	71.83mm	19.00mm	8.99mm	2.58mm	65.13mm	52.83mm	12.32mm	6.15mm	52.83mm	11.99mm	75.00mm	
			M	N	P	Q	R	S	T	U	V	W	X	Weight
6830	15		.656"	1.253"	1.500"	10-32 FHSCS			.328"	1.500"	.656"	.375"	.625"	.708 lb
6830-Black	15		.656"	1.253"	1.500"	10-32 FHSCS			.328"	1.500"	.656"	.375"	.625"	.708 lb
40-6830	40		17.50mm	32.56mm	40.00mm	10-32 FHSCS			8.33mm	40.00mm	17.50mm	9.53mm	17.42mm	.3415 kg
40-6830-Black	40		17.50mm	32.56mm	40.00mm	10-32 FHSCS			8.33mm	40.00mm	17.50mm	9.53mm	17.42mm	.3415 kg

3 Slot Mount - Single Flange Short High-Cycle Linear Bearing with Brake Holes

Part No.	Series	Color	A	B	C	D	E	F	G	H	J	K	L	
6530	15	Clear	2.750"	.750"	.375"	.125"	2.505"	2.005"	.493"	.250"	2.000"	.500"	2.812"	
6530-Black	15	Black	2.750"	.750"	.375"	.125"	2.505"	2.005"	.493"	.250"	2.000"	.500"	2.812"	
40-6530	40	Clear	71.83mm	19.00mm	8.99mm	2.58mm	65.13mm	52.83mm	12.32mm	6.15mm	52.83mm	11.99mm	75.00mm	
40-6530-Black	40	Black	71.83mm	19.00mm	8.99mm	2.58mm	65.13mm	52.83mm	12.32mm	6.15mm	52.83mm	11.99mm	75.00mm	
			M	N	P	Q	R	S	T	U	V	W	X	Weight
6530	15	1.406"	.656"	1.253"	1.500"	10-32 FHSCS	.344"	.328"	1.500"	.656"	.375"	.625"	.697 lb	
6530-Black	15	1.406"	.656"	1.253"	1.500"	10-32 FHSCS	.344"	.328"	1.500"	.656"	.375"	.625"	.697 lb	
40-6530	40	37.50mm	17.50mm	32.56mm	40.00mm	10-32 FHSCS	8.71mm	8.33mm	40.00mm	17.50mm	9.53mm	17.42mm	.3371 kg	
40-6530-Black	40	37.50mm	17.50mm	32.56mm	40.00mm	10-32 FHSCS	8.71mm	8.33mm	40.00mm	17.50mm	9.53mm	17.42mm	.3371 kg	

Material Specifications

Material	Alloy*	Process	Finish
Aluminum	6105-T5	Extrude	Anodize

* Or comparable

3 Slot Mount - Single Flange Long High-Cycle Linear Bearing

Part Description:

The 3 slot mount – single flange long high-cycle linear bearing with or without brake holes is typically used in linear motion applications. It contains special threaded inserts in the pads which provide a heavy-duty bearing capable of withstanding repetitive cycles with sudden acceleration and deceleration. The bearing houses profiles with a minimum of three open T-slots, has a single flange and is a longer option. The pads, screws and shims are included; the pads are made of self-lubricating UHMW. All 80/20 bearing are designed for compression loads only and not intended to support hanging loads.



Fractional



Metric



Black Anodized

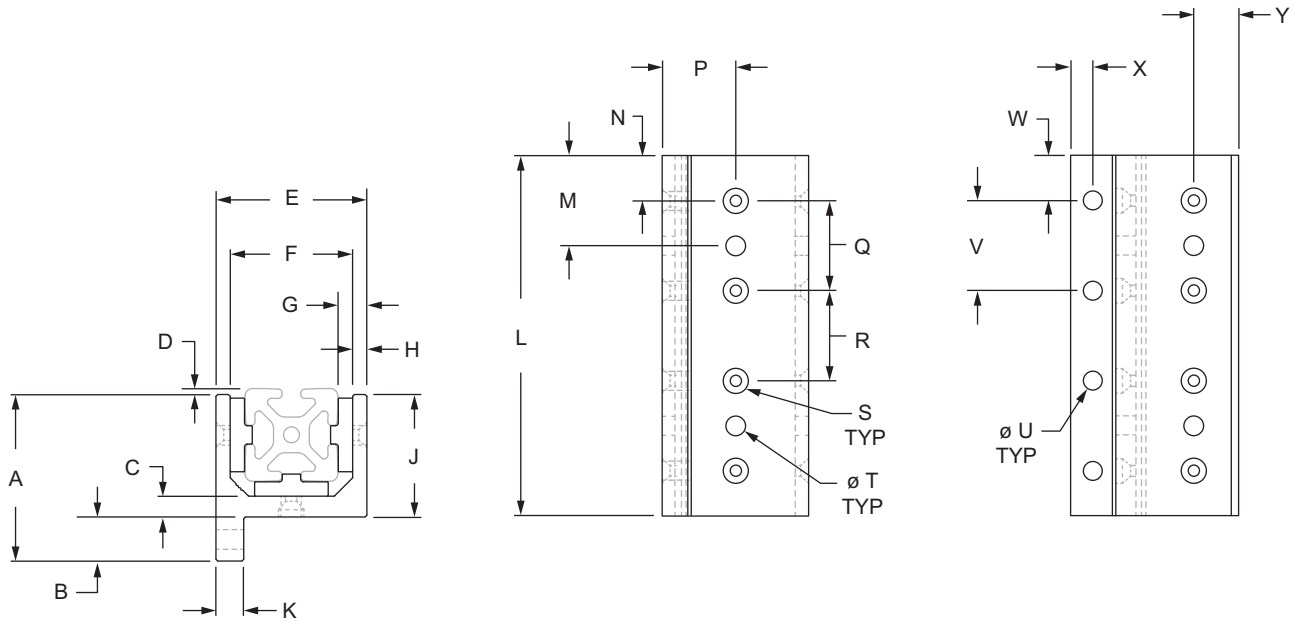

CONTINUE

80/20[®]
3 Slot Mount - Single Flange Long High-Cycle Linear Bearing (Continued)

3 Slot Mount - Single Flange Long High-Cycle Linear Bearing

Part No.	Series	Color	A	B	C	D	E	F	G	H	J	K	L	M
6831	15	Clear	2.750"	.750"	.375"	.125"	2.505"	2.005"	.493"	.250"	2.000"	.500"	6.000"	—
6831-Black	15	Black	2.750"	.750"	.375"	.125"	2.505"	2.005"	.493"	.250"	2.000"	.500"	6.000"	
40-6831	40	Clear	71.83mm	19.00mm	8.99mm	2.58mm	65.13mm	52.83mm	12.32mm	6.15mm	52.83mm	11.99mm	160.00mm	
40-6831-Black	40	Black	71.83mm	19.00mm	8.99mm	2.58mm	65.13mm	52.83mm	12.32mm	6.15mm	52.83mm	11.99mm	160.00mm	
			N	P	Q	R	S	T	U	V	W	X	Y	Weight
6831	15	Clear	.750"	1.253"	1.500"	1.500"	10-32 FHSCS	—	.328"	1.500"	.656"	.375"	.625"	1.495 lb
6831-Black	15	Black	.750"	1.253"	1.500"	1.500"	10-32 FHSCS		.328"	1.500"	.656"	.375"	.625"	1.495 lb
40-6831	40	Clear	20.00mm	32.56mm	40.00mm	40.00mm	10-32 FHSCS		8.33mm	40.00mm	20.00mm	9.53mm	17.42mm	.7166 kg
40-6831-Black	40	Black	20.00mm	32.56mm	40.00mm	40.00mm	10-32 FHSCS		8.33mm	40.00mm	20.00mm	9.53mm	17.42mm	.7166 kg

3 Slot Mount - Single Flange Long High-Cycle Linear Bearing with Brake Holes

Part No.	Series	Color	A	B	C	D	E	F	G	H	J	K	L	M
6531	15	Clear	2.750"	.750"	.375"	.125"	2.505"	2.005"	.493"	.250"	2.000"	.500"	6.000"	1.500"
6531-Black	15	Black	2.750"	.750"	.375"	.125"	2.505"	2.005"	.493"	.250"	2.000"	.500"	6.000"	1.500"
40-6531	40	Clear	71.83mm	19.00mm	8.99mm	2.58mm	65.13mm	52.83mm	12.32mm	6.15mm	52.83mm	11.99mm	160.00mm	40.00mm
40-6531-Black	40	Black	71.83mm	19.00mm	8.99mm	2.58mm	65.13mm	52.83mm	12.32mm	6.15mm	52.83mm	11.99mm	160.00mm	40.00mm
			N	P	Q	R	S	T	U	V	W	X	Y	Weight
6531	15	Clear	.750"	1.253"	1.500"	1.500"	10-32 FHSCS	.344"	.328"	1.500"	.656"	.375"	.625"	1.476 lb
6531-Black	15	Black	.750"	1.253"	1.500"	1.500"	10-32 FHSCS	.344"	.328"	1.500"	.656"	.375"	.625"	1.476 lb
40-6531	40	Clear	20.00mm	32.56mm	40.00mm	40.00mm	10-32 FHSCS	8.71mm	8.33mm	40.00mm	20.00mm	9.53mm	17.42mm	.7087 kg
40-6531-Black	40	Black	20.00mm	32.56mm	40.00mm	40.00mm	10-32 FHSCS	8.71mm	8.33mm	40.00mm	20.00mm	9.53mm	17.42mm	.7087 kg

Material Specifications

Material	Alloy*	Process	Finish
Aluminum	6105-T5	Extrude	Anodize

* Or comparable

3 Slot Mount - Double Flange Short High-Cycle Linear Bearing

Part Description:

The 3 slot mount – double flange short high-cycle linear bearing with or without brake holes is typically used in linear motion applications. It contains special threaded inserts in the pads which provide a heavy-duty bearing capable of withstanding repetitive cycles with sudden acceleration and deceleration. The bearing houses profiles with a minimum of three open T-slots, has a double flange and is a shorter option. The pads, screws and shims are included; the pads are made of self-lubricating UHMW. All 80/20 bearing are designed for compression loads only and not intended to support hanging loads.



Fractional



Metric



Black Anodized

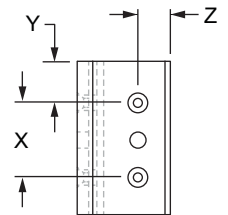
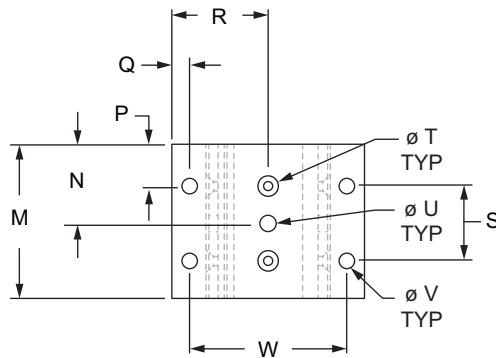
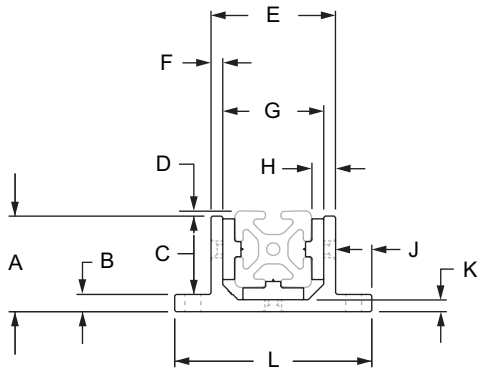

CONTINUE

80/20[®] 3 Slot Mount - Double Flange Short High-Cycle Linear Bearing (Continued)

3 Slot Mount - Double Flange Short High-Cycle Linear Bearing

Part No.	Series	Color	A	B	C	D	E	F	G	H	J	K	L	M
6835	15	Clear	1.875"	.375"	1.500"	.125"	2.505"	.250"	2.005"	.493"	.748"	.250"	4.000"	2.812"
6835-Black	15	Black	1.875"	.375"	1.500"	.125"	2.505"	.250"	2.005"	.493"	.748"	.250"	4.000"	2.812"
40-6835	40	Clear	50.00mm	9.00mm	41.00mm	2.58mm	65.12mm	6.15mm	52.82mm	12.32mm	19.00mm	6.15mm	103.12mm	75.00mm
40-6835-Black	40	Black	50.00mm	9.00mm	41.00mm	2.58mm	65.12mm	6.15mm	52.82mm	12.32mm	19.00mm	6.15mm	103.12mm	75.00mm
		N	P	Q	R	S	T	U	V	W	X	Y	Z	Weight
6835	15		.656"	.375"	2.000"	1.500"	10-32 FHSCS		.328"	3.250"	1.500"	.656"	.625"	.673 lb
6835-Black	15		.656"	.375"	2.000"	1.500"	10-32 FHSCS		.328"	3.250"	1.500"	.656"	.625"	.673 lb
40-6835	40		17.50mm	9.50mm	51.56mm	40.00mm	10-32 FHSCS		8.33mm	84.12mm	40.00mm	17.50mm	17.42mm	.3140 kg
40-6835-Black	40		17.50mm	9.50mm	51.56mm	40.00mm	10-32 FHSCS		8.33mm	84.12mm	40.00mm	17.50mm	17.42mm	.3140 kg

3 Slot Mount - Double Flange Short High-Cycle Linear Bearing with Brake Holes

Part No.	Series	Color	A	B	C	D	E	F	G	H	J	K	L	M
6535	15	Clear	1.875"	.375"	1.500"	.125"	2.505"	.250"	2.005"	.493"	.748"	.250"	4.000"	2.812"
6535-Black	15	Black	1.875"	.375"	1.500"	.125"	2.505"	.250"	2.005"	.493"	.748"	.250"	4.000"	2.812"
40-6535	40	Clear	50.00mm	9.00mm	41.00mm	2.58mm	65.12mm	6.15mm	52.82mm	12.32mm	19.00mm	6.15mm	103.12mm	75.00mm
40-6535-Black	40	Black	50.00mm	9.00mm	41.00mm	2.58mm	65.12mm	6.15mm	52.82mm	12.32mm	19.00mm	6.15mm	103.12mm	75.00mm
		N	P	Q	R	S	T	U	V	W	X	Y	Z	Weight
6535	15	1.406"	.656"	.375"	2.000"	1.500"	10-32 FHSCS	.344"	.328"	3.250"	1.500"	.656"	.625"	.665 lb
6535-Black	15	1.406"	.656"	.375"	2.000"	1.500"	10-32 FHSCS	.344"	.328"	3.250"	1.500"	.656"	.625"	.665 lb
40-6535	40	37.50mm	17.50mm	9.50mm	51.56mm	40.00mm	10-32 FHSCS	8.71mm	8.33mm	84.12mm	40.00mm	17.50mm	17.42mm	.3172 kg
40-6535-Black	40	37.50mm	17.50mm	9.50mm	51.56mm	40.00mm	10-32 FHSCS	8.71mm	8.33mm	84.12mm	40.00mm	17.50mm	17.42mm	.3172 kg

Material Specifications

Material	Alloy*	Process	Finish
Aluminum	6105-T5	Extrude	Anodize

* Or comparable

3 Slot Mount - Double Flange Long High-Cycle Linear Bearing

Part Description:

The 3 slot mount – double flange long high-cycle linear bearing with or without brake holes is typically used in linear motion applications. It contains special threaded inserts in the pads which provide a heavy-duty bearing capable of withstanding repetitive cycles with sudden acceleration and deceleration. The bearing houses profiles with a minimum of three open T-slots, has a double flange and is a longer option. The pads, screws and shims are included; the pads are made of self-lubricating UHMW. All 80/20 bearings are designed for compression loads only and not intended to support hanging loads.



Fractional



Metric



Black Anodized

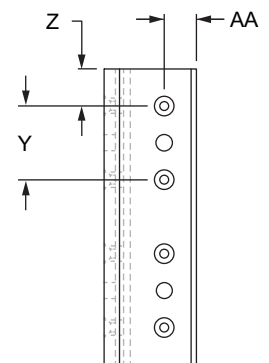
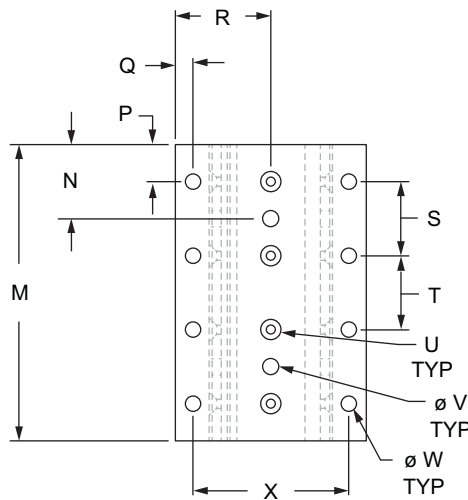
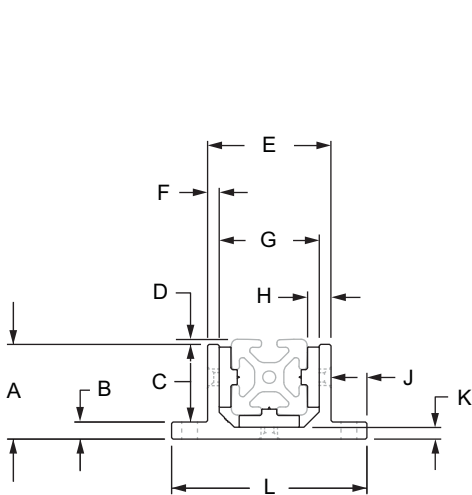

CONTINUE

80/20[®] 3 Slot Mount - Double Flange Long High-Cycle Linear Bearing (Continued)

3 Slot Mount - Double Flange Long High-Cycle Linear Bearing

Part No.	Series	Color	A	B	C	D	E	F	G	H	J	K	L	M	N
6836	15	Clear	1.875"	.375"	1.500"	.125"	2.505"	.250"	2.005"	.493"	.748"	.250"	4.000"	6.000"	—
6836-Black	15	Black	1.875"	.375"	1.500"	.125"	2.505"	.250"	2.005"	.493"	.748"	.250"	4.000"	6.000"	
40-6836	40	Clear	50.00mm	9.00mm	41.00mm	2.58mm	65.12mm	6.15mm	52.82mm	12.32mm	19.00mm	6.15mm	103.12mm	160.00mm	
40-6836-Black	40	Black	50.00mm	9.00mm	41.00mm	2.58mm	65.12mm	6.15mm	52.82mm	12.32mm	19.00mm	6.15mm	103.12mm	160.00mm	
			P	Q	R	S	T	U	V	W	X	Y	Z	AA	Weight
6836	15	Clear	.750"	.375"	2.000"	1.500"	1.500"	10-32 FHSCS	—	.328"	3.250"	1.500"	.750"	.625"	1.425 lb
6836-Black	15	Black	.750"	.375"	2.000"	1.500"	1.500"	10-32 FHSCS		.328"	3.250"	1.500"	.750"	.625"	1.425 lb
40-6836	40	Clear	20.00mm	9.50mm	51.56mm	40.00mm	40.00mm	10-32 FHSCS		8.33mm	84.12mm	40.00mm	20.00mm	17.42mm	.6852 kg
40-6836-Black	40	Black	20.00mm	9.50mm	51.56mm	40.00mm	40.00mm	10-32 FHSCS		8.33mm	84.12mm	40.00mm	20.00mm	17.42mm	.6852 kg

3 Slot Mount - Double Flange Long High-Cycle Linear Bearing with Brake Holes

Part No.	Series	Color	A	B	C	D	E	F	G	H	J	K	L	M	N
6536	15	Clear	1.875"	.375"	1.500"	.125"	2.505"	.250"	2.005"	.493"	.748"	.250"	4.000"	6.000"	1.500"
6536-Black	15	Black	1.875"	.375"	1.500"	.125"	2.505"	.250"	2.005"	.493"	.748"	.250"	4.000"	6.000"	1.500"
40-6536	40	Clear	50.00mm	9.00mm	41.00mm	2.58mm	65.12mm	6.15mm	52.82mm	12.32mm	19.00mm	6.15mm	103.12mm	160.00mm	40.00mm
40-6536-Black	40	Black	50.00mm	9.00mm	41.00mm	2.58mm	65.12mm	6.15mm	52.82mm	12.32mm	19.00mm	6.15mm	103.12mm	160.00mm	40.00mm
			P	Q	R	S	T	U	V	W	X	Y	Z	AA	Weight
6536	15	Clear	.750"	.375"	2.000"	1.500"	1.500"	10-32 FHSCS	.344"	.328"	3.250"	1.500"	.750"	.625"	1.408 lb
6536-Black	15	Black	.750"	.375"	2.000"	1.500"	1.500"	10-32 FHSCS	.344"	.328"	3.250"	1.500"	.750"	.625"	1.408 lb
40-6536	40	Clear	20.00mm	9.50mm	51.56mm	40.00mm	40.00mm	10-32 FHSCS	8.71mm	8.33mm	84.12mm	40.00mm	20.00mm	17.42mm	.6814 kg
40-6536-Black	40	Black	20.00mm	9.50mm	51.56mm	40.00mm	40.00mm	10-32 FHSCS	8.71mm	8.33mm	84.12mm	40.00mm	20.00mm	17.42mm	.6814 kg

Material Specifications

Material	Alloy*	Process	Finish
Aluminum	6105-T5	Extrude	Anodize

* Or comparable

4 Slot Mount - Double Flange Short High-Cycle Linear Bearing

Part Description:

The 4 slot mount – double flange short high-cycle linear bearing with or without brake holes is typically used in linear motion applications. It contains special threaded inserts in the pads which provide a heavy-duty bearing capable of withstanding repetitive cycles with sudden acceleration and deceleration. The bearing houses profiles with a minimum of four open T-slots, has a double flange and is a shorter option. The pads, screws and shims are included; the pads are made of self-lubricating UHMW. All 80/20 bearings are designed for compression loads only and not intended to support hanging loads.



Fractional



Metric



Black Anodized

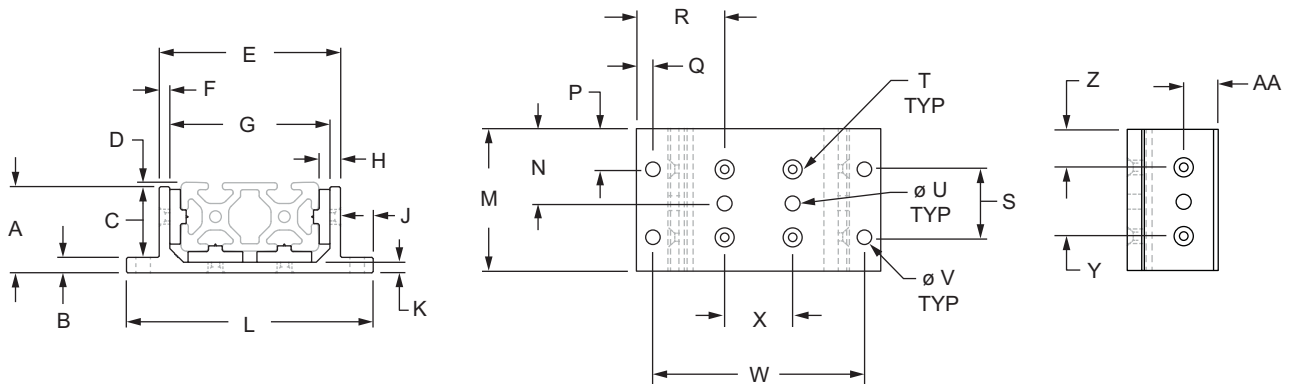

CONTINUE

80/20[®] 4 Slot Mount - Double Flange Short High-Cycle Linear Bearing (Continued)

4 Slot Mount - Double Flange Short High-Cycle Linear Bearing

Part No.	Series	Color	A	B	C	D	E	F	G	H	J	K	L	M	N
6833	15	Clear	1.875"	.375"	1.500"	.125"	4.005"	.250"	3.505"	.493"	.748"	.250"	5.500"	2.812"	—
6833-Black	15	Black	1.875"	.375"	1.500"	.125"	4.005"	.250"	3.505"	.493"	.748"	.250"	5.500"	2.812"	
40-6833	40	Clear	50.00mm	9.00mm	41.00mm	2.58mm	105.31mm	6.15mm	93.01mm	12.32mm	19.00mm	6.15mm	143.31mm	75.00mm	
40-6833-Black	40	Black	50.00mm	9.00mm	41.00mm	2.58mm	105.31mm	6.15mm	93.01mm	12.32mm	19.00mm	6.15mm	143.31mm	75.00mm	
			P	Q	R	S	T	U	V	W	X	Y	Z	AA	Weight
6833	15	Clear	.656"	2.000"	.375"	1.500"	10-32 FHSCS	—	.328"	4.750"	1.500"	1.500"	.656"	.625"	.818 lb
6833-Black	15	Black	.656"	2.000"	.375"	1.500"	10-32 FHSCS		.328"	4.750"	1.500"	1.500"	.656"	.625"	.818 lb
40-6833	40	Clear	17.50mm	51.66mm	9.50mm	40.00mm	10-32 FHSCS		8.33mm	124.31mm	40.00mm	40.00mm	17.50mm	17.42mm	.3842 kg
40-6833-Black	40	Black	17.50mm	51.66mm	9.50mm	40.00mm	10-32 FHSCS		8.33mm	124.31mm	40.00mm	40.00mm	17.50mm	17.42mm	.3842 kg

4 Slot Mount - Double Flange Short High-Cycle Linear Bearing with Brake Holes

Part No.	Series	Color	A	B	C	D	E	F	G	H	J	K	L	M	N
6533	15	Clear	1.875"	.375"	1.500"	.125"	4.005"	.250"	3.505"	.493"	.748"	.250"	5.500"	2.812"	1.406"
6533-Black	15	Black	1.875"	.375"	1.500"	.125"	4.005"	.250"	3.505"	.493"	.748"	.250"	5.500"	2.812"	1.406"
40-6533	40	Clear	50.00mm	9.00mm	41.00mm	2.58mm	105.31mm	6.15mm	93.01mm	12.32mm	19.00mm	6.15mm	143.31mm	75.00mm	37.50mm
40-6533-Black	40	Black	50.00mm	9.00mm	41.00mm	2.58mm	105.31mm	6.15mm	93.01mm	12.32mm	19.00mm	6.15mm	143.31mm	75.00mm	37.50mm
			P	Q	R	S	T	U	V	W	X	Y	Z	AA	Weight
6533	15	Clear	.656"	2.000"	.375"	1.500"	10-32 FHSCS	.343"	.328"	4.750"	1.500"	1.500"	.656"	.625"	.808 lb
6533-Black	15	Black	.656"	2.000"	.375"	1.500"	10-32 FHSCS	.343"	.328"	4.750"	1.500"	1.500"	.656"	.625"	.808 lb
40-6533	40	Clear	17.50mm	51.66mm	9.50mm	40.00mm	10-32 FHSCS	8.71mm	8.33mm	124.31mm	40.00mm	40.00mm	17.50mm	17.42mm	.3916 kg
40-6533-Black	40	Black	17.50mm	51.66mm	9.50mm	40.00mm	10-32 FHSCS	8.71mm	8.33mm	124.31mm	40.00mm	40.00mm	17.50mm	17.42mm	.3916 kg

Material Specifications

Material	Alloy*	Process	Finish
Aluminum	6105-T5	Extrude	Anodize

* Or comparable

4 Slot Mount - Double Flange Long High-Cycle Linear Bearing

Part Description:

The 4 slot mount – double flange long high-cycle linear bearing with or without brake holes is typically used in linear motion applications. It contains special threaded inserts in the pads which provide a heavy-duty bearing capable of withstanding repetitive cycles with sudden acceleration and deceleration. The bearing houses profiles with a minimum of four open T-slots, has a double flange and is a longer option. The pads, screws and shims are included; the pads are made of self-lubricating UHMW. All 80/20 bearings are designed for compression loads only and not intended to support hanging loads.



Fractional



Metric



Black Anodized

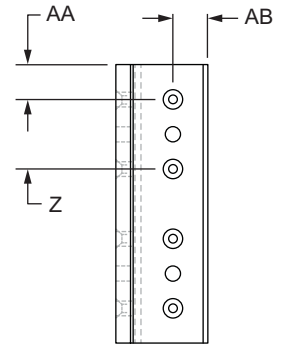
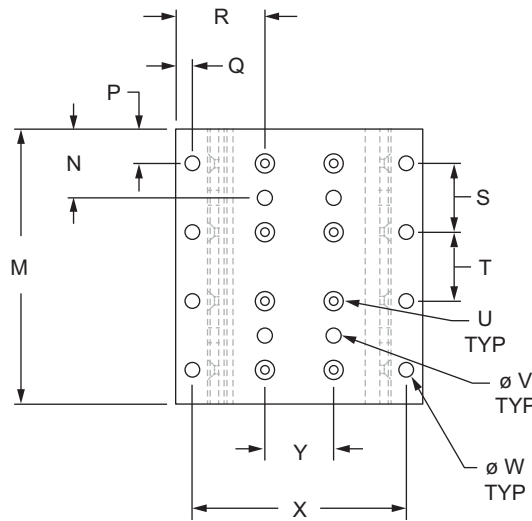
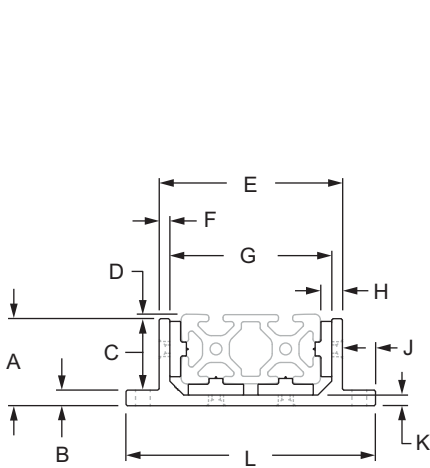

CONTINUE

80/20[®] 4 Slot Mount - Double Flange Long High-Cycle Linear Bearing (Continued)

4 Slot Mount - Double Flange Long High-Cycle Linear Bearing

Part No.	Series	Color	A	B	C	D	E	F	G	H	J	K	L	M	N	
6834	15	Clear	1.875"	.375"	1.500"	.125"	4.005"	.250"	3.505"	.493"	.748"	.250"	5.500"	6.000"	—	
6834-Black	15	Black	1.875"	.375"	1.500"	.125"	4.005"	.250"	3.505"	.493"	.748"	.250"	5.500"	6.000"		
40-6834	40	Clear	50.00mm	9.00mm	41.00mm	2.58mm	105.31mm	6.15mm	93.01mm	12.32mm	19.00mm	6.15mm	143.31mm	160.00mm		
40-6834-Black	40	Black	50.00mm	9.00mm	41.00mm	2.58mm	105.31mm	6.15mm	93.01mm	12.32mm	19.00mm	6.15mm	143.31mm	160.00mm		
			P	Q	R	S	T	U	V	W	X	Y	Z	AA	AB	Weight
6834	15		.750"	.375"	2.000"	1.500"	1.500"	10-32 FHSCS	—	.328"	4.750"	1.500"	1.500"	.750"	.625"	1.727 lb
6834-Black	15		.750"	.375"	2.000"	1.500"	1.500"	10-32 FHSCS		.328"	4.750"	1.500"	1.500"	.750"	.625"	1.727 lb
40-6834	40		20.00mm	9.50mm	51.66mm	40.00mm	40.00mm	10-32 FHSCS		8.33mm	124.31mm	40.00mm	40.00mm	20.00mm	17.42mm	.8142 kg
40-6834-Black	40		20.00mm	9.50mm	51.66mm	40.00mm	40.00mm	10-32 FHSCS		8.33mm	124.31mm	40.00mm	40.00mm	20.00mm	17.42mm	.8142 kg

4 Slot Mount - Double Flange Long High-Cycle Linear Bearing with Brake Holes

Part No.	Series	Color	A	B	C	D	E	F	G	H	J	K	L	M	N	
6534	15	Clear	1.875"	.375"	1.500"	.125"	4.005"	.250"	3.505"	.493"	.748"	.250"	5.500"	6.000"	1.500"	
6534-Black	15	Black	1.875"	.375"	1.500"	.125"	4.005"	.250"	3.505"	.493"	.748"	.250"	5.500"	6.000"	1.500"	
40-6534	40	Clear	50.00mm	9.00mm	41.00mm	2.58mm	105.31mm	6.15mm	93.01mm	12.32mm	19.00mm	6.15mm	143.31mm	160.00mm	40.00mm	
40-6534-Black	40	Black	50.00mm	9.00mm	41.00mm	2.58mm	105.31mm	6.15mm	93.01mm	12.32mm	19.00mm	6.15mm	143.31mm	160.00mm	40.00mm	
			P	Q	R	S	T	U	V	W	X	Y	Z	AA	AB	Weight
6534	15		.750"	.375"	2.000"	1.500"	1.500"	10-32 FHSCS	.343"	.328"	4.750"	1.500"	1.500"	.750"	.625"	1.706 lb
6534-Black	15		.750"	.375"	2.000"	1.500"	1.500"	10-32 FHSCS	.343"	.328"	4.750"	1.500"	1.500"	.750"	.625"	1.706 lb
40-6534	40		20.00mm	9.50mm	51.66mm	40.00mm	40.00mm	10-32 FHSCS	8.71mm	8.33mm	124.31mm	40.00mm	40.00mm	20.00mm	17.42mm	.8204 kg
40-6534-Black	40		20.00mm	9.50mm	51.66mm	40.00mm	40.00mm	10-32 FHSCS	8.71mm	8.33mm	124.31mm	40.00mm	40.00mm	20.00mm	17.42mm	.8204 kg

Material Specifications

Material	Alloy*	Process	Finish
Aluminum	6105-T5	Extrude	Anodize

* Or comparable

Single Short UniBearing™

Part Description:

The single short UniBearing™ has an open design that enables customized layouts. It is an option that is commonly used in applications with one guiderail. The UniBearing™ is easy to quickly install or remove without taking it apart, allowing reduced retooling and downtime and increased productivity and flexibility. The pads are mounted using stainless steel flathead socket cap screws that secure it to the housing and eliminate the need for high-cycle pads. The bearing can move or be fixed; when fixed, it allows the guardrail and assembly to move. All UniBearings™ come with pre-drilled brake holes and tapped mounting holes that enable attachment of accessories to a flat surface.

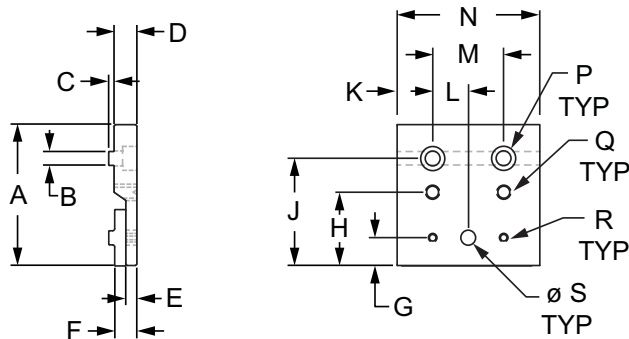

Part No.	Series	Color	A	B	C	D	E	F	G	H	J
6760	10	Clear	2.063"	.244"	.060"	.312"	.156"	.306"	.398"	1.063"	1.563"
6760-Black	10	Black	2.063"	.244"	.060"	.312"	.156"	.306"	.398"	1.063"	1.563"
6860	15	Clear	3.125"	.309"	.120"	.505"	.245"	.485"	.616"	1.625"	2.375"
6860-Black	15	Black	3.125"	.309"	.120"	.505"	.245"	.485"	.616"	1.625"	3.375"
25-6760	25	Clear	52.40mm	6.20mm	1.52mm	7.92mm	3.96mm	7.77mm	10.11mm	27.00mm	39.70mm
25-6760-Black	25	Black	52.40mm	6.20mm	1.52mm	7.92mm	3.96mm	7.77mm	10.11mm	27.00mm	39.70mm
40-6860	40	Clear	82.45mm	7.85mm	3.05mm	12.83mm	6.22mm	12.32mm	15.78mm	42.45mm	62.39mm
40-6860-Black	40	Black	82.45mm	7.85mm	3.05mm	12.83mm	6.22mm	12.32mm	15.78mm	42.45mm	62.39mm
			K	L	M	N	P	Q	R	S	Weight
6760	10	Clear	.437"	.500"	1.000"	1.875"	1/4-20 SHCS	1/4-20	8-32	.257"	.129 lb
6760-Black	10	Black	.437"	.500"	1.000"	1.875"	1/4-20 SHCS	1/4-20	8-32	.257"	.129 lb
6860	15	Clear	.656"	.750"	1.500"	2.812"	5/16 SHCS	5/16-18	10-24	.328"	.449 lb
6860-Black	15	Black	.656"	.750"	1.500"	2.812"	5/16 SHCS	5/16-18	10-24	.328"	.449 lb
25-6760	25	Clear	11.00mm	12.50mm	25.00mm	47.00mm	M6 SHCS	M6 x 1.0	8-32	6.30mm	.0611 kg
25-6760-Black	25	Black	11.00mm	12.50mm	25.00mm	47.00mm	M6 SHCS	M6 x 1.0	8-32	6.30mm	.0611 kg
40-6860	40	Clear	17.50mm	20.00mm	40.00mm	75.00mm	M8 SHCS	M8 x 1.25	10-24	8.33mm	.2157 kg
40-6860-Black	40	Black	17.50mm	20.00mm	40.00mm	75.00mm	M8 SHCS	M8 x 1.25	10-24	8.33mm	.2157 kg

Material Specifications

Material	Alloy*	Process	Finish
Aluminum	6105-T5	Extrude	Anodize

* Or comparable

Included Hardware (Mount to T-Slot)

Series	Part No.	Qty.	Bolt	Part No.	Qty.	T-Nut
10	3058	2	1/4-20 x 3/8" SHCS	3280	1	Double Slide-in Economy
15	3110	2	5/16-18 x 5/8" SHCS	3279	1	Double Slide-in Economy
25	13-6508	2	M6 x 8mm SHCS	25-1962	1	Double Slide-in Economy
40	13-8516	2	M8 x 16mm SHCS	40-1982	1	Double Slide-in Economy



Part Description:

The single long UniBearing™ has an open design that enables customized layouts. It is an option that is commonly used in applications with one guiderail. The UniBearing™ is easy to quickly install or remove without taking it apart, allowing reduced retooling and downtime and increased productivity and flexibility. The pads are mounted using stainless steel flathead socket cap screws that secure it to the housing and eliminate the need for high-cycle pads. The bearing can move or be fixed; when fixed, it allows the guardrail and assembly to move. All UniBearings™ come with pre-drilled brake holes and tapped mounting holes that enable attachment of accessories to a flat surface.

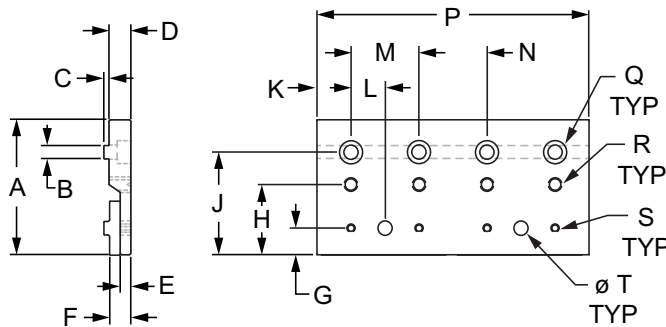

Part No.	Series	Color	A	B	C	D	E	F	G	H	J	
6762	10	Clear	2.063"	.244"	.060"	.312"	.156"	.306"	.398"	1.063"	1.563"	
6762-Black	10	Black	2.063"	.244"	.060"	.312"	.156"	.306"	.398"	1.063"	1.563"	
6862	15	Clear	3.125"	.309"	.120"	.505"	.245"	.485"	.616"	1.625"	2.375"	
6862-Black	15	Black	3.125"	.309"	.120"	.505"	.245"	.485"	.616"	1.625"	2.375"	
25-6762	25	Clear	52.40mm	6.20mm	1.52mm	7.92mm	3.96mm	4.85mm	10.11mm	27.00mm	39.70mm	
25-6762-Black	25	Black	52.40mm	6.20mm	1.52mm	7.92mm	3.96mm	4.85mm	10.11mm	27.00mm	39.70mm	
40-6862	40	Clear	82.45mm	7.85mm	3.05mm	12.83mm	6.22mm	12.32mm	15.78mm	42.45mm	62.39mm	
40-6862-Black	40	Black	82.45mm	7.85mm	3.05mm	12.83mm	6.22mm	12.32mm	15.78mm	42.45mm	62.39mm	
			K	L	M	N	P	Q	R	S	T	Weight
6762	10	.437"	.500"	1.000"	1.000"	4.000"	1/4-20 SHCS	1/4-20	8-32	.257"	.265 lb	
6762-Black	10	.437"	.500"	1.000"	1.000"	4.000"	1/4-20 SHCS	1/4-20	8-32	.257"	.265 lb	
6862	15	.750"	.750"	1.500"	1.500"	6.000"	5/16 SHCS	5/16-18	10-24	.328"	.933 lb	
6862-Black	15	.750"	.750"	1.500"	1.500"	6.000"	5/16 SHCS	5/16-18	10-24	.328"	.933 lb	
25-6762	25	12.50mm	12.50mm	25.00mm	25.00mm	100.00mm	M6 SHCS	M6 x 1.0	8-32	6.30mm	.1240 kg	
25-6762-Black	25	12.50mm	12.50mm	25.00mm	25.00mm	100.00mm	M6 SHCS	M6 x 1.0	8-32	6.30mm	.1240 kg	
40-6862	40	20.00mm	20.00mm	40.00mm	40.00mm	160.00mm	M8 SHCS	M8 x 1.25	10-24	8.33mm	.4522 kg	
40-6862-Black	40	20.00mm	20.00mm	40.00mm	40.00mm	160.00mm	M8 SHCS	M8 x 1.25	10-24	8.33mm	.4522 kg	

Material Specifications

Material	Alloy*	Process	Finish
Aluminum	6105-T5	Extrude	Anodize

* Or comparable

Included Hardware (Mount to T-Slot)

Series	Part No.	Qty.	Bolt	Part No.	Qty.	T-Nut
10	3058	4	1/4-20 x 3/8" SHCS	3280	2	Double Slide-in Economy
15	3110	4	5/16-18 x 5/8" SHCS	3279	2	Double Slide-in Economy
25	13-6508	4	M6 x 8mm SHCS	25-1962	2	Double Slide-in Economy
40	13-8516	4	M8 x 16mm SHCS	40-1982	2	Double Slide-in Economy

Double Short UniBearing™

Part Description:

The double short UniBearing™ has an open design that enables customized layouts. It is an option that is commonly used in applications with two guiderails. The UniBearing™ is easy to quickly install or remove without taking it apart, allowing reduced retooling and downtime and increased productivity and flexibility. The pads are mounted using stainless steel flathead socket cap screws that secure it to the housing and eliminate the need for high-cycle pads. The bearing can move or be fixed; when fixed, it allows the guardrail and assembly to move. All UniBearings™ come with pre-drilled brake holes and tapped mounting holes that enable attachment of accessories to a flat surface.

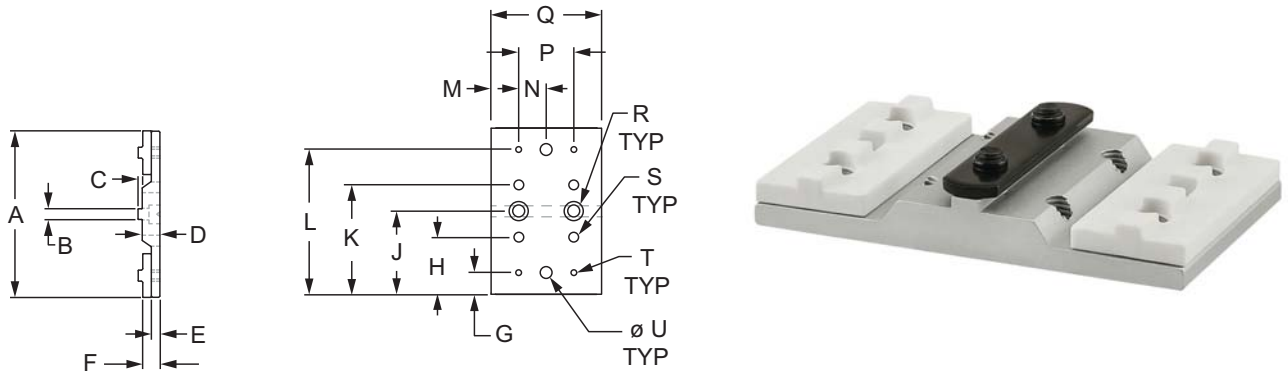

Part No.	Series	Color	A	B	C	D	E	F	G	H	J	K
6764	10	Clear	3.125"	.244"	.060"	.312"	.156"	.306"	.397"	1.063"	1.563"	2.063"
6764-Black	10	Black	3.125"	.244"	.060"	.312"	.156"	.306"	.397"	1.063"	1.563"	2.063"
6864	15	Clear	4.750"	.308"	.120"	.505"	.245"	.485"	.616"	1.625"	2.375"	3.125"
6864-Black	15	Black	4.750"	.308"	.120"	.505"	.245"	.485"	.616"	1.625"	2.375"	3.125"
25-6764	25	Clear	79.38mm	6.20mm	1.52mm	7.92mm	3.96mm	7.77mm	10.08mm	27.00mm	39.70mm	52.40mm
25-6764-Black	25	Black	79.38mm	6.20mm	1.52mm	7.92mm	3.96mm	7.77mm	10.08mm	27.00mm	39.70mm	52.40mm
40-6864	40	Clear	124.78mm	7.82mm	3.05mm	12.83mm	6.22mm	12.32mm	15.78mm	42.45mm	62.39mm	82.33mm
40-6864-Black	40	Black	124.78mm	7.82mm	3.05mm	12.83mm	6.22mm	12.32mm	15.78mm	42.45mm	62.39mm	82.33mm
			L	M	N	P	Q	R	S	T	U	Weight
6764	10	Clear	2.728"	.437"	.500"	1.000"	1.875"	1/4-20 SHCS	1/4-20	8-32	.257"	.173 lb
6764-Black	10	Black	2.728"	.437"	.500"	1.000"	1.875"	1/4-20 SHCS	1/4-20	8-32	.257"	.173 lb
6864	15	Clear	4.134"	.656"	.750"	1.500"	2.812"	5/16 SHCS	5/16-18	10-24	.328"	.588 lb
6864-Black	15	Black	4.134"	.656"	.750"	1.500"	2.812"	5/16 SHCS	5/16-18	10-24	.328"	.588 lb
25-6764	25	Clear	69.29mm	11.00mm	12.50mm	25.00mm	47.00mm	M6 SHCS	M6 x 1.0	8-32	6.30mm	.0819 kg
25-6764-Black	25	Black	69.29mm	11.00mm	12.50mm	25.00mm	47.00mm	M6 SHCS	M6 x 1.0	8-32	6.30mm	.0819 kg
40-6864	40	Clear	109.00mm	17.50mm	20.00mm	40.00mm	75.00mm	M8 SHCS	M8 x 1.25	10-24	8.33mm	.2840 kg
40-6864-Black	40	Black	109.00mm	17.50mm	20.00mm	40.00mm	75.00mm	M8 SHCS	M8 x 1.25	10-24	8.33mm	.2840 kg

Material Specifications

Material	Alloy*	Process	Finish
Aluminum	6105-T5	Extrude	Anodized

* Or comparable

Included Hardware (Mount to T-Slot)

Series	Part No.	Qty.	Bolt	Part No.	Qty.	T-Nut
10	3058	2	1/4-20 x 3/8" SHCS	3280	1	Double Slide-in Economy
15	3110	2	5/16-18 x 5/8" SHCS	3279	1	Double Slide-in Economy
25	13-6508	2	M6 x 8mm SHCS	25-1962	1	Double Slide-in Economy
40	13-8516	2	M8 x 16mm SHCS	40-1982	1	Double Slide-in Economy



Part Description:

The double long UniBearing™ has an open design that enables customized layouts. It is an option that is commonly used in applications with two guiderails. The UniBearing™ is easy to quickly install or remove without taking it apart, allowing reduced retooling and downtime and increased productivity and flexibility. The pads are mounted using stainless steel flathead socket cap screws that secure it to the housing and eliminate the need for high-cycle pads. The bearing can move or be fixed; when fixed, it allows the guardrail and assembly to move. All UniBearings™ come with pre-drilled brake holes and tapped mounting holes that enable attachment of accessories to a flat surface.

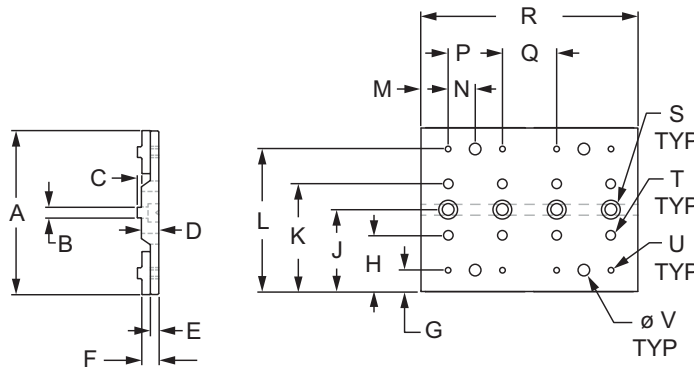

Part No.	Series	Color	A	B	C	D	E	F	G	H	J	K	
6766	10	Clear	3.125"	.244"	.060"	.312"	.156"	.306"	.397"	1.063"	1.563"	2.063"	
6766-Black	10	Black	3.125"	.244"	.060"	.312"	.156"	.306"	.397"	1.063"	1.563"	2.063"	
6866	15	Clear	4.750"	.308"	.120"	.505"	.245"	.485"	.616"	1.625"	2.375"	3.125"	
6866-Black	15	Black	4.750"	.308"	.120"	.505"	.245"	.485"	.616"	1.625"	2.375"	3.125"	
25-6766	25	Clear	79.38mm	6.20mm	1.52mm	7.92mm	3.96mm	7.77mm	10.08mm	27.00mm	39.70mm	52.40mm	
25-6766-Black	25	Black	79.38mm	6.20mm	1.52mm	7.92mm	3.96mm	7.77mm	10.08mm	27.00mm	39.70mm	52.40mm	
40-6866	40	Clear	124.78mm	7.82mm	3.05mm	12.83mm	6.22mm	12.32mm	15.78mm	42.45mm	62.39mm	82.33mm	
40-6866-Black	40	Black	124.78mm	7.82mm	3.05mm	12.83mm	6.22mm	12.32mm	15.78mm	42.45mm	62.39mm	82.33mm	
			L	M	N	P	Q	R	S	T	U	V	Weight
6766	10	2.728"	.500"	.500"	1.000"	1.000"	4.000"	1/4-20 SHCS	1/4-20	8-32	.257"	.359 lb	
6766-Black	10	2.728"	.500"	.500"	1.000"	1.000"	4.000"	1/4-20 SHCS	1/4-20	8-32	.257"	.359 lb	
6866	15	4.134"	.750"	.750"	1.500"	1.500"	6.000"	5/16 SHCS	5/16-18	10-24	.328"	1.272 lb	
6866-Black	15	4.134"	.750"	.750"	1.500"	1.500"	6.000"	5/16 SHCS	5/16-18	10-24	.328"	1.272 lb	
25-6766	25	69.29mm	12.50mm	12.50mm	25.00mm	25.00mm	100.00mm	M6 SHCS	M6 x 1.0	8-32	6.30mm	.1641 kg	
25-6766-Black	25	69.29mm	12.50mm	12.50mm	25.00mm	25.00mm	100.00mm	M6 SHCS	M6 x 1.0	8-32	6.30mm	.1641 kg	
40-6866	40	109.00mm	20.00mm	20.00mm	40.00mm	40.00mm	160.00mm	M8 SHCS	M8 x 1.25	10-24	8.33mm	.5973 kg	
40-6866-Black	40	109.00mm	20.00mm	20.00mm	40.00mm	40.00mm	160.00mm	M8 SHCS	M8 x 1.25	10-24	8.33mm	.5973 kg	

Material Specifications

Material	Alloy*	Process	Finish
Aluminum	6105-T5	Extrude	Anodize

* Or comparable

Included Hardware (Mount to T-Slot)

Series	Part No.	Qty.	Bolt	Part No.	Qty.	T-Nut
10	3058	4	1/4-20 x 3/8" SHCS	3280	2	Double Slide-in Economy
15	3110	4	5/16-18 x 5/8" SHCS	3279	2	Double Slide-in Economy
25	13-6508	4	M6 x 8mm SHCS	25-1962	2	Double Slide-in Economy
40	13-8516	4	M8 x 16mm SHCS	40-1982	2	Double Slide-in Economy

Short - Single Mount UniBearing™ Assembly

Part Description:

The short – single mount UniBearing™ assembly is commonly used for linear motion applications and is comprised of a short single mount UniBearing™ that is attached to a T-slot profile. There are pre-tapped holes in the profile ends as well as in the housing unit for connecting accessories. Shim kits are included.

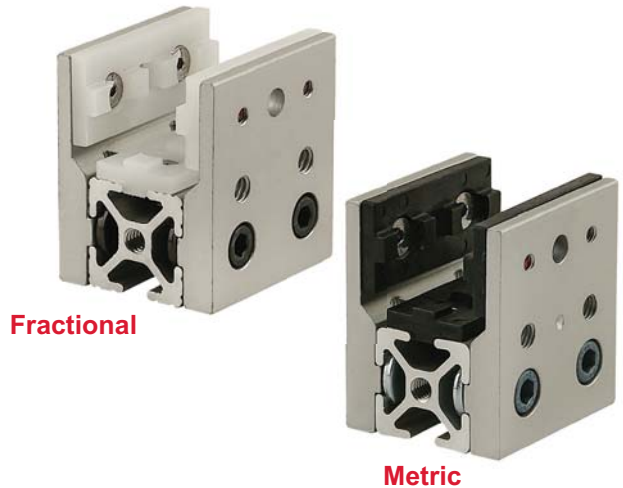
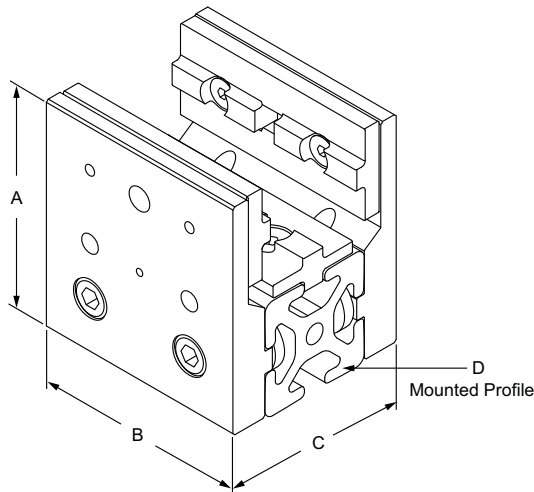

Part No.	Series	Material	Alloy*	Finish	Process	Color	A	B	C	D	Weight
6730	10	Aluminum	6105-T5	Anodize	Extrude	Clear	2.063"	1.875"	1.624"	1010	.378 lb
6730-Black	10					Black	2.063"	1.875"	1.624"	1010	.378 lb
6731	10					Clear	2.063"	1.875"	2.624"	1020	.467 lb
6731-Black	10					Black	2.063"	1.875"	2.624"	1020	.467 lb
6870	15					Clear	3.125"	2.812"	2.510"	1515	1.330 lb
6870-Black	15					Black	3.125"	2.812"	2.510"	1515	1.330 lb
6871	15					Clear	3.125"	2.812"	4.010"	1530	1.682 lb
6871-Black	15					Black	3.125"	2.812"	4.010"	1530	1.682 lb
6872	15					Clear	3.125"	2.812"	5.510"	1545	2.036 lb
6872-Black	15					Black	3.125"	2.812"	5.510"	1545	2.036 lb
25-6730	25					Clear	52.40mm	47.00mm	40.85mm	25-2525	.1600 kg
25-6730-Black	25					Black	52.40mm	47.00mm	40.85mm	25-2525	.1600 kg
25-6731	25					Clear	52.40mm	47.00mm	65.85mm	25-2550	.2070 kg
25-6731-Black	25					Black	52.40mm	47.00mm	65.85mm	25-2550	.2070 kg
40-6870	40					Clear	82.45mm	75.00mm	65.66mm	40-4040	.6550 kg
40-6870-Black	40					Black	82.45mm	75.00mm	65.66mm	40-4040	.6550 kg
40-6871	40					Clear	82.45mm	75.00mm	105.66mm	40-4080	.7919 kg
40-6871-Black	40					Black	82.45mm	75.00mm	105.66mm	40-4080	.7919 kg

* Or comparable

Included Hardware (Mount to T-Slot)

Series	Part No.	Qty.	Bolt	Part No.	Qty.	T-Nut
10	3058	4	1/4-20 x 3/8" SHCS	3280	2	Double Slide-in Economy
15	3110	4	5/16-18 x 5/8" SHCS	3279	2	Double Slide-in Economy
25	13-6508	4	M6 x 8mm SHCS	25-1962	2	Double Slide-in Economy
40	13-8516	4	M8 x 16mm SHCS	40-1982	2	Double Slide-in Economy



Part Description:

The long – single mount UniBearing™ assembly is commonly used for linear motion applications and is comprised of a long single mount UniBearing™ that is attached to a T-slot profile. There are pre-tapped holes in the profile ends as well as in the housing unit for connecting accessories. Shim kits are included.

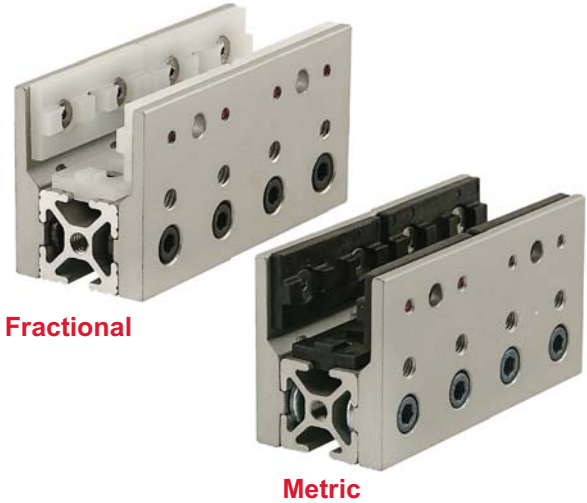
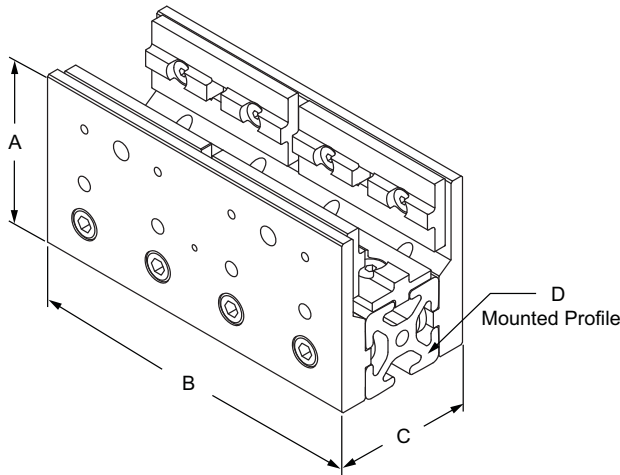

Part No.	Series	Material	Alloy*	Finish	Process	Color	A	B	C	D	Weight
6732	10	Aluminum	6105-T5	Anodize	Extrude	Clear	2.063"	4.000"	1.624"	1010	.771 lb
6732-Black	10					Black	2.063"	4.000"	1.624"	1010	.771 lb
6733	10					Clear	2.063"	4.000"	2.624"	1020	.969 lb
6733-Black	10					Black	2.063"	4.000"	2.624"	1020	.969 lb
6873	15					Clear	3.125"	6.000"	2.510"	1515	2.751 lb
6873-Black	15					Black	3.125"	6.000"	2.510"	1515	2.751 lb
6874	15					Clear	3.125"	6.000"	4.010"	1530	3.518 lb
6874-Black	15					Black	3.125"	6.000"	4.010"	1530	3.518 lb
6875	15					Clear	3.125"	6.000"	5.510"	1545	5.030 lb
6875-Black	15					Black	3.125"	6.000"	5.510"	1545	5.030 lb
25-6732	25					Clear	52.40mm	100.00mm	40.85mm	25-2525	.3394 kg
25-6732-Black	25					Black	52.40mm	100.00mm	40.85mm	25-2525	.3394 kg
25-6733	25					Clear	52.40mm	100.00mm	65.85mm	25-2550	.4277 kg
25-6733-Black	25					Black	52.40mm	100.00mm	65.85mm	25-2550	.4277 kg
40-6873	40					Clear	82.45mm	160.00mm	65.66mm	40-4040	1.3290 kg
40-6873-Black	40					Black	82.45mm	160.00mm	65.66mm	40-4040	1.3290 kg
40-6874	40					Clear	82.45mm	160.00mm	105.66mm	40-4080	1.6720 kg
40-6874-Black	40					Black	82.45mm	160.00mm	105.66mm	40-4080	1.6720 kg

* Or comparable

Included Hardware (Mount to T-Slot)

Series	Part No.	Qty.	Bolt	Part No.	Qty.	T-Nut
10	3058	8	1/4-20 x 3/8" SHCS	3280	4	Double Slide-in Economy
15	3110	8	5/16-18 x 5/8" SHCS	3279	4	Double Slide-in Economy
25	13-6508	8	M6 x 8mm SHCS	25-1962	4	Double Slide-in Economy
40	13-8516	8	M8 x 16mm SHCS	40-1982	4	Double Slide-in Economy

Short - Double Mount UniBearing™ Assembly

Part Description:

The short – double mount UniBearing™ assembly is commonly used for linear motion applications and is comprised of a short double mount UniBearing™ that is attached to a T-slot profile. There are pre-tapped holes in the profile ends as well as in the housing unit for connecting accessories. Shim kits are included.

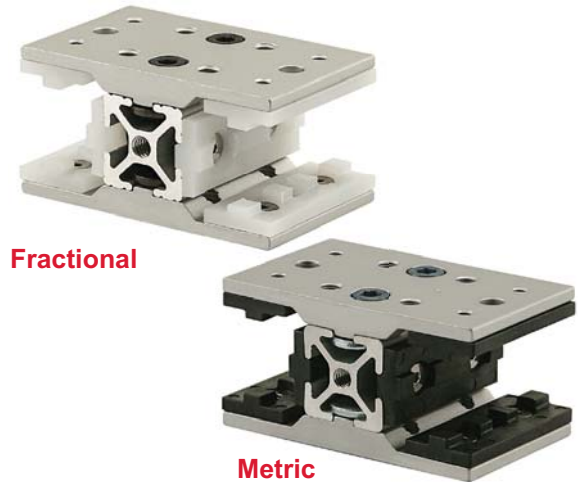
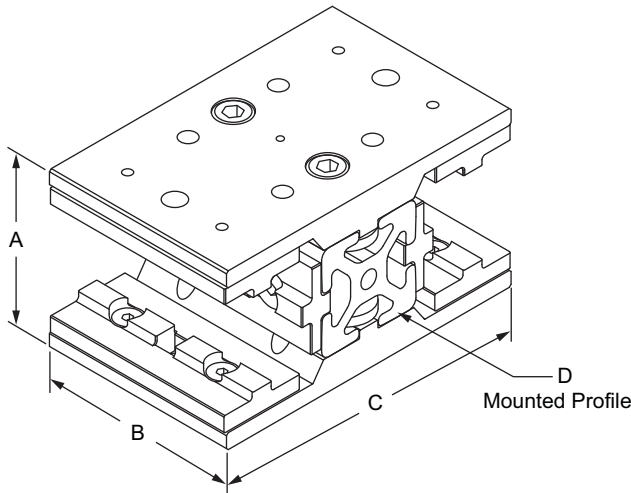

Part No.	Series	Material	Alloy*	Finish	Process	Color	A	B	C	D	Weight
6734	10	Aluminum	6105-T5	Anodize	Extrude	Clear	1.624"	1.875"	3.125"	1010	.485 lb
6734-Black	10					Black	1.624"	1.875"	3.125"	1010	.485 lb
6735	10					Clear	2.624"	1.875"	3.125"	1020	.609 lb
6735-Black	10					Black	2.624"	1.875"	3.125"	1020	.609 lb
6876	15					Clear	2.510"	2.812"	4.750"	1515	1.791 lb
6876-Black	15					Black	2.510"	2.812"	4.750"	1515	1.791 lb
6877	15					Clear	4.010"	2.812"	4.750"	1530	1.860 lb
6877-Black	15					Black	4.010"	2.812"	4.750"	1530	1.860 lb
6878	15					Clear	5.510"	2.812"	4.750"	1545	2.196 lb
6878-Black	15					Black	5.510"	2.812"	4.750"	1545	2.196 lb
25-6734	25					Clear	40.85mm	47.00mm	79.38mm	25-2525	.2128 kg
25-6734-Black	25					Black	40.85mm	47.00mm	79.38mm	25-2525	.2128 kg
25-6735	25					Clear	65.85mm	47.00mm	79.38mm	25-2550	.2692 kg
25-6735-Black	25					Black	65.85mm	47.00mm	79.38mm	25-2550	.2692 kg
40-6876	40					Clear	65.66mm	75.00mm	124.78mm	40-4040	.9020 kg
40-6876-Black	40					Black	65.66mm	75.00mm	124.78mm	40-4040	.9020 kg
40-6877	40					Clear	105.66mm	75.00mm	124.78mm	40-4080	1.0970 kg
40-6877-Black	40					Black	105.66mm	75.00mm	124.78mm	40-4080	1.0970 kg

* Or comparable

Included Hardware (Mount to T-Slot)

Series	Part No.	Qty.	Bolt	Part No.	Qty.	T-Nut
10	3058	4	1/4-20 x 3/8" SHCS	3280	2	Double Slide-in Economy
15	3110	4	5/16-18 x 5/8" SHCS	3279	2	Double Slide-in Economy
25	13-6508	4	M6 x 8mm SHCS	25-1962	2	Double Slide-in Economy
40	13-8516	4	M8 x 16mm SHCS	40-1982	2	Double Slide-in Economy



Part Description:

The long – double mount UniBearing™ assembly is commonly used for linear motion applications and is comprised of a long double mount UniBearing™ that is attached to a T-slot profile. There are pre-tapped holes in the profile ends as well as in the housing unit for connecting accessories. Shim kits are included.

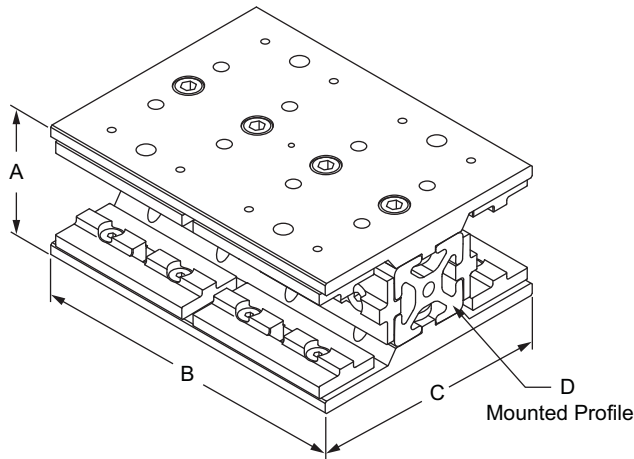

Fractional



Metric

Part No.	Series	Material	Alloy*	Finish	Process	Color	A	B	C	D	Weight
6736	10	Aluminum	6105-T5	Anodize	Extrude	Clear	1.624"	4.000"	3.125"	1010	1.033 lb
6736-Black	10					Black	1.624"	4.000"	3.125"	1010	1.033 lb
6737	10					Clear	2.624"	4.000"	3.125"	1020	1.301 lb
6737-Black	10					Black	2.624"	4.000"	3.125"	1020	1.301 lb
6879	15					Clear	2.510"	6.000"	4.750"	1515	3.608 lb
6879-Black	15					Black	2.510"	6.000"	4.750"	1515	3.608 lb
6883	15					Clear	4.010"	6.000"	4.750"	1530	4.568 lb
6883-Black	15					Black	4.010"	6.000"	4.750"	1530	4.568 lb
6884	15					Clear	5.510"	6.000"	4.750"	1545	5.577 lb
6884-Black	15					Black	5.510"	6.000"	4.750"	1545	5.577 lb
25-6736	25					Clear	40.85mm	100.00mm	79.38mm	25-2525	.4397 kg
25-6736-Black	25					Black	40.85mm	100.00mm	79.38mm	25-2525	.4397 kg
25-6737	25					Clear	65.85mm	100.00mm	79.38mm	25-2550	.5540 kg
25-6737-Black	25					Black	65.85mm	100.00mm	79.38mm	25-2550	.5540 kg
40-6879	40					Clear	65.66mm	160.00mm	124.78mm	40-4040	1.6780 kg
40-6879-Black	40					Black	65.66mm	160.00mm	124.78mm	40-4040	1.6780 kg
40-6883	40					Clear	105.66mm	160.00mm	124.78mm	40-4080	2.0825 kg
40-6883-Black	40					Black	105.66mm	160.00mm	124.78mm	40-4080	2.0825 kg

* Or comparable

Included Hardware (Mount to T-Slot)

Series	Part No.	Qty.	Bolt	Part No.	Qty.	T-Nut
10	3058	8	1/4-20 x 3/8" SHCS	3280	4	Double Slide-in Economy
15	3110	8	5/16-18 x 5/8" SHCS	3279	4	Double Slide-in Economy
25	13-6508	8	M6 x 8mm SHCS	25-1962	4	Double Slide-in Economy
40	13-8516	8	M8 x 16mm SHCS	40-1982	4	Double Slide-in Economy

Linear Bearing Brake Hole Specifications

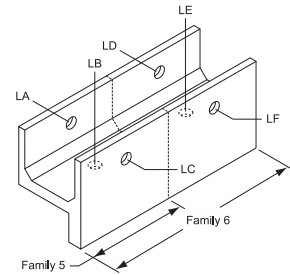
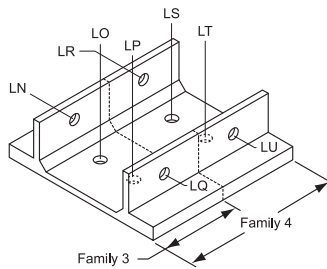
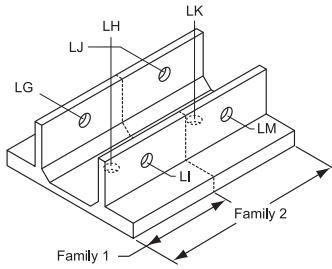

Part No.	Series	Description
7401	10	.265" diameter drill thru one wall
7400	15	.344" diameter drill thru one wall

Part No.	Series	Description
25-7401	25	6.73mm diameter drill thru one wall
40-7400	40	8.73mm diameter drill thru one wall

Series	Standard Bearing Part No.	Brake Ready Bearing Part No.	Series	Standard Bearing Part No.	Brake Ready Bearing Part No.	Bearing Size	Pre-Drilled or Specified Brake Hole Locations
10	6725	—	25	25-6725	—	Family 1	Specific*
15	6825	—	40	40-6825	—		LG / LH / LI
15	6835	—	40	40-6835	—		
10	—	6425	25	—	25-6425	Family 2	Specify*
15	—	6525	40	—	40-6525		LG / LH / LI / LJ / LK / LM
15	—	6535	40	—	40-6535		
10	6726	—	25	25-6726	—	Family 3	Specify*
15	6826	—	40	40-6826	—		LN / LO / LP / LQ
15	6836	—	40	40-6836	—		
10	—	6426	25	—	25-6426	Family 4	Specify*
15	—	6526	40	—	40-6526		LN / LO / LP / LQ / LR / LS / LT / LU
15	—	6536	40	—	40-6536		
10	6723	—	25	25-6723	—	Family 5	Specify*
15	6823	—	40	40-6823	—		LA / LB / LC
15	6833	—	40	40-6833	—		
10	—	6423	25	—	25-6423	Family 6	Specify*
15	—	6523	40	—	40-6523		LA / LB / LC / LD / LE / LF
15	—	6533	40	—	40-6533		
10	6724	—	25	25-6724	—	Family 1	Specify*
15	6824	—	40	40-6824	—		LA / LB / LC
15	6834	—	40	40-6834	—		
10	—	6424	25	—	25-6424	Family 2	Specify*
15	—	6524	40	—	40-6524		LA / LB / LC
15	—	6534	40	—	40-6534		
10	6715	—	25	25-6715	—	Family 3	Specify*
15	6815	—	40	40-6815	—		LA / LB / LC
15	6830	—	40	40-6830	—		
10	—	6415	25	—	25-6415	Family 4	Specify*
15	—	6515	40	—	40-6515		LA / LB / LC
15	—	6530	40	—	40-6530		
10	6716	—	25	25-6716	—	Family 5	Specify*
15	6816	—	40	40-6816	—		LA / LB / LC / LD / LE / LF
15	6831	—	40	40-6831	—		
10	—	6416	25	—	25-6416	Family 6	Specify*
15	—	6516	40	—	40-6516		LA / LB / LC / LD / LE / LF
15	—	6531	40	—	40-6531		

* Refer to pages 873-874 for machining services

Engineering Specifications on UHMW-PE Bearing Pads

Property	Test Method	Unit	Typical Value
Specific Gravity	ASTM D-792	g/cm ³	0.94
Yield Strength @ 73°F	ASTM D-638	p.s.i.	3400
Ultimate Tensile Strength @ 73°F	ASTM D-638	p.s.i.	6800
Break Elongation @ 73°F	ASTM D-638	%	450
Yield Strength @ 250°F	Stress Strain Diagram	p.s.i.	700
Ultimate Tensile Strength @ 250°F	Stress Strain Diagram	p.s.i.	3300
Break Elongation @ 250°F	Stress Strain Diagram	%	900
Hardness - Rockwell "R" Scale	ASTM D-785	-	64
- Shore "D" Scale	ASTM D-2240	-	67
Flexural Modulus of Elasticity	Bend Creep/1 min. value	p.s.i.	110,000
Shear Strength	ASTM D-732	p.s.i.	3500
Izod Impact @ + 23°C	ASTM D-256A	ft-lbs/in. notch	No break
@ - 140° C	ASTM D-256A	ft-lbs/in. notch	No break
Environmental Stress Cracking @ F50	ASTM D-1693 Mod	hrs.	6000
Water Absorption	ASTM D-570	-	NIL

Abrasive Resistance - Sand Slurry Test

- Each material listed below was rotated 24 hours @ 1750 r.p.m.
- Carbon Steel = abrasive rating of 100.
- The weight loss for each material is relative to 100.
- The lower the figure, the better the abrasive resistance.
- 50-50 sand/water slurry.

Material	Rating	Material	Rating	Material	Rating
UHMW-PE	15	Polypropylene	87	Normal MW polyethylene	125
Nylon	31	Polycarbonate	96	Phosphor bronze	193
High MW polyethylene	44	Hi carbon steel	100	Yellow brass	409
TFE	72	Polyacetal	110	Phenolic laminate	571
Stainless steel	84	TFE/glass fiber	113	Hickory wood	967

Coefficient of Friction

UHMW-PE polymer has a lower coefficient of friction than glass. Its self-lubricating characteristics make it an ideal material for bearings, bushings, valves, wear strips, or any application where sliding contact is encountered.

Materials	Static	Kinetic	Test Method
Aluminum* vs. UHMW-PE	0.12	0.016	ASTM D-1894
Mild Steel vs. Mild Steel	0.30 - 0.40	0.25 - 0.35	
Mild Steel vs. UHMW-PE	0.15 - 0.20	0.12 - 0.20	
UHMW-PE vs. UHMW-PE	0.20 - 0.30	0.20 - 0.30	

*Anodized 204 R1 Spec on extruded aluminum

Comparison of Dynamic Coefficient of Friction on Polished Steel

Property	UHMW-PE
Dry	0.10 - 0.22
Water	0.05 - 0.10
Oil	0.05 - 0.08

**FDA and USDA
Approved**

Load Bearing Properties of UHMW-PE

Torsional Rigidity As A Function Of Temperature
(Measured On Compression - Molded Sheets)

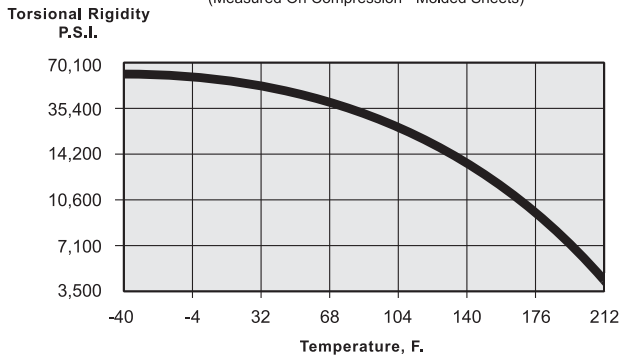

Tensile Strength At The Yield Point As A Function Of Temperature
(Measured At The Feed Rate Of 3.9 in. / min.)

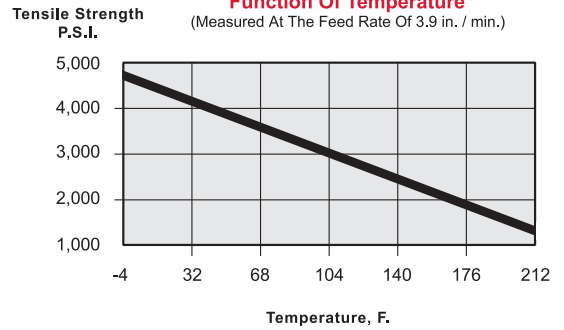

Stress - Strain At Various Temperatures
(Measured At The Feed Rate Of 1 in. / min.)

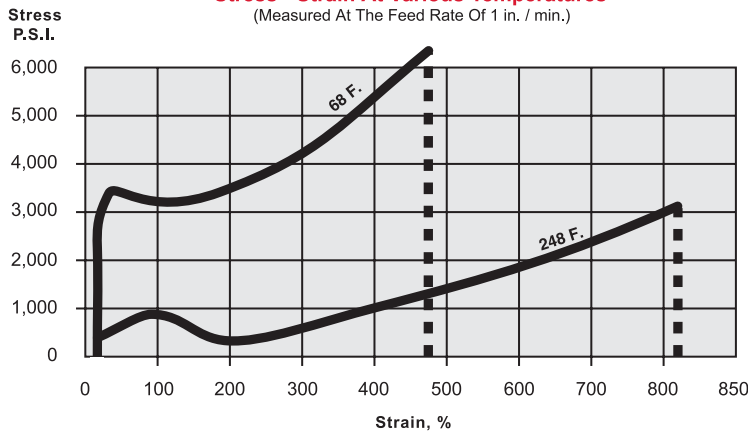

Flexural Modulus Of Elasticity
P.S.I.

Flexural Modulus Of Elasticity As A Function Of Load Time
(Measured By The Bending Creep Test With A Constant Bending Stress Of 425 P.S.I.)

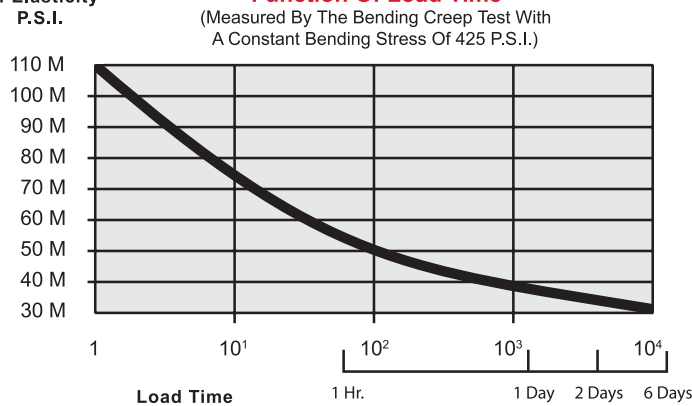

Chemical Resistance of UHMW-PE

TEST SPECIMENS	Dumb-bell type
DURATION OF TEST	30 Days
+ = RESISTANT	Mechanical properties not appreciably affected
/ = LIMITED RESISTANT	Decreases in yield stress and ultimate tensile strength less than 20%
- = NOT RESISTANT	Decreases in yield stress and ultimate tensile strength greater than 20%

Reagent	Temperatures		
	20°C	50°C	80°C
I. Inorganic acids			
Chromic acid (80%)	+	+	/
Hydrochloric acid (conc.)	+	+	+
Hydrocyanic acid	+	+	
Hydrofluoric acid	-	-	-
Nitric acid (conc.)	/	-	
Nitric acid (50%)	+	+	/
Nitric acid (20%)	+	+	+
Phosphoric acid (85%)	+	-	-
Sulphuric acid (conc.)	+	-	-
Sulphuric acid (50%)	+	+	+
II. Alkalis			
Aqueous ammonia	+	+	
Potassium hydroxide solution	+	+	+
Sodium hydroxide solution	+	+	+
III. Aqueous solutions of inorganic salts			
Aluminum chloride	+	+	+
Ammonium nitrate	+	+	+
Bleaching powder	+	+	+
Calcium chloride	+	+	+
Sodium carbonate	+	+	+
Sodium chloride	+	+	+
Sodium hypochlorite	+	+	+
Zinc chloride	+	+	+
IV. Organic acids			
Acetic acid (99%)	+	+	/
Acetic acid (10%)	+	+	+
Butyric acid	+	+	
Citric acid	+	+	+
Formic acid	+	+	
Oleic acid	+	+	/

Reagent	Temperatures		
	20°C	50°C	80°C
V. Hydrocarbons and halogenated hydrocarbons			
Benzene	/	/	
Carbon tetrachloride	/		
Cyclohexane	+	+	
Dichloroethylene	-	-	
Diesel oil	+	+	/
n-Heptane	+	+	
Petroleum ether	+		
Trichloroethylene	/	-	
Toluene	/	-	
White spirit	+	/	
Xylene	/	/	-
VI. Alcohols, Ketones, Ester, and Amines			
Acetone	+	+	
Aniline	+	+	/
Benzyl alcohol	+	+	+
Butyl alcohol	+	+	+
Cyclohexanol	+	+	+
Ethanol	+	+	
Ethyl acetate	+	+	
Ethylene glycol	+	+	+
Glycerine	+	+	+
Lauryl alcohol	+	+	+
Propyl alcohol	+	+	+
VII. Miscellaneous			
Beer	+	+	+
Detergents in aqueous solution	+	+	+
Distilled water	+	+	+
Hydrogen peroxide 30% (perhydrol)	+	+	
Linseed oil	+	+	+
Milk	+	+	+
Olive oil	+	+	+
Sea water	+	+	+
Wine	+	+	+

Because we cannot anticipate or control the many different conditions under which our products may be used, the product information contained in this catalog should be viewed as general guidelines only and not as a recommendation to use our products in any particular situation. Although we believe that all information contained herein is reliable, certain information in this catalog may have been obtained from test results published by other parties, and consequently, we cannot guarantee the accuracy of all information contained in this catalog. In addition, particular conditions of use and reasonable lot-to-lot variations can affect performance. Users of our products should perform their own tests to determine the suitability of any product for their particular purposes.

Single-Keyed Standard Linear Bearing Pad

Part Description:

The single-keyed standard linear bearing pad is commonly used with bearings to create linear motion and is made of easily machined, self-lubricating UHMW. It has a low coefficient of friction and is designed with rounded corners on the molded pad, allowing simple installation and replacement. This pad is available in black or white and has a single key; it comes with holes for mounting hardware and brake kits.

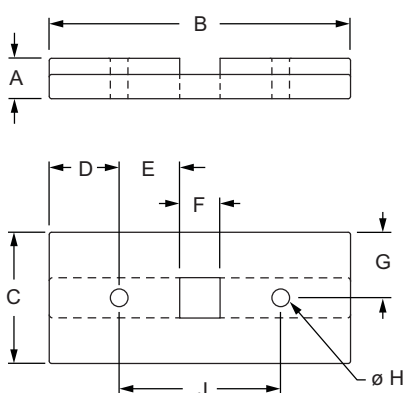

Part No.	Series	A	B	C	D	E	F	G	H	J	K	L	M	Weight
6490	10	.250"	1.865"	.812"	.433"	.375"	.250"	.406"	.109"	1.000"	.150"	.283"	.246"	.008 lb
6491	10	.250"	1.865"	.812"	.433"	.375"	.250"	.406"	.109"	1.000"	.150"	.283"	.246"	.008 lb
6590	15	.375"	2.770"	1.250"	.635"	.594"	.312"	.625"	.125"	1.500"	.243"	.469"	.312"	.029 lb
6591	15	.375"	2.770"	1.250"	.635"	.594"	.312"	.625"	.125"	1.500"	.243"	.469"	.312"	.029 lb
25-6490	25	6.35mm	46.69mm	20.62mm	10.84mm	9.33mm	6.35mm	10.31mm	2.77mm	25.00mm	3.81mm	7.19mm	6.25mm	.0036 kg
25-6491	25	6.35mm	46.69mm	20.62mm	10.84mm	9.33mm	6.35mm	10.31mm	2.77mm	25.00mm	3.81mm	7.19mm	6.25mm	.0035 kg
40-6590	40	9.53mm	74.12mm	31.75mm	17.06mm	16.04mm	7.92mm	15.88mm	3.18mm	40.00mm	6.17mm	11.91mm	7.92mm	.0140 kg
40-6591	40	9.53mm	74.12mm	31.75mm	17.06mm	16.04mm	7.92mm	15.88mm	3.18mm	40.00mm	6.17mm	11.91mm	7.92mm	.0145 kg

Material Specifications

Part No.	Material	Process	Finish	Color
6490	UHMW PE	Injection Mold	Smooth	White
6491				Black
6590				White
6591				Black
25-6490		Extruded		White
25-6491				Black
40-6590				Natural
40-6591				Black

Suggested Hardware (Mount Pad to Bearing Housing)

Part No.	Series	Qty.	Bolt
3625	10	2	#8 x 3/8" Bearing Pad Screw
3628	15	2	#10 x 5/8" Bearing Pad Screw
25-3625	25	2	#8 x 3/8" Bearing Pad Screw
40-3628	40	2	#10 x 5/8" Bearing Pad Screw

Part Description:

The single-keyed high-cycle linear bearing pad is a higher strength pad ideal for quick acceleration and deceleration linear motion applications. It is made of easily machined, self-lubricating UHMW and has a low coefficient of friction. The design includes rounded corners on the molded pad, allowing simple installation and replacement. This pad is available in black or white and has a single key and mounts to the housing using steel flathead socket cap screws that have Loctite[®]. It comes with holes for mounting hardware or brake kits and includes nutserts.

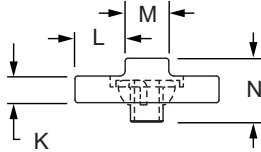
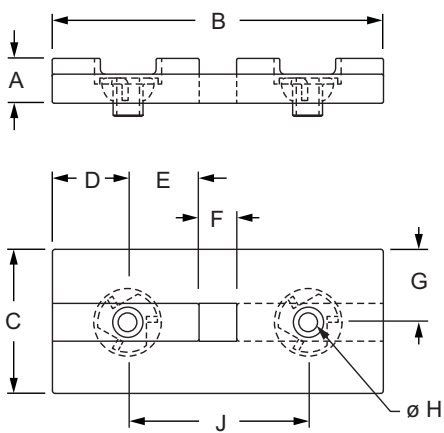

Part No.	Series	A	B	C	D	E	F	G	H	J	K	L	M	N	Weight
6595	15	.375"	2.770"	1.250"	.635"	.594"	.312"	.625"	10-32	1.500"	.243"	.469"	.312"	.484"	.033 lb
6596	15	.375"	2.770"	1.250"	.635"	.594"	.312"	.625"	10-32	1.500"	.243"	.469"	.312"	.484"	.032 lb
40-6595	40	9.53mm	74.12mm	31.75mm	17.06mm	16.04mm	7.92mm	15.88mm	10-32	40.00mm	6.17mm	11.91mm	7.92mm	12.29mm	.0159 kg
40-6596	40	9.53mm	74.12mm	31.75mm	17.06mm	16.04mm	7.92mm	15.88mm	10-32	40.00mm	6.17mm	11.91mm	7.92mm	12.29mm	.0158 kg

Material Specifications

Part No.	Material	Process	Finish	Color
6595	UHMW PE	Injection Mold	Smooth	White
6596				Black
40-6595		Extruded		Natural
40-6596				Black

Suggested Hardware (Mount Pad to Bearing Housing)

Part No.	Series	Qty.	Bolt
3022	15 40	2	10-32 x 1/2" FHSCS

T-Slot Insert Linear Bearing Pad

Part Description:

The T-slot insert linear bearing pad is commonly used with bearings to create linear motion and is made of easily machined, self-lubricating white UHMW. It has a low coefficient of friction and is designed with rounded corners on the molded pad, allowing simple installation and replacement. This pad is designed to slide into, and stabilize within, the T-slot. It comes with holes for mounting hardware and brake kits.

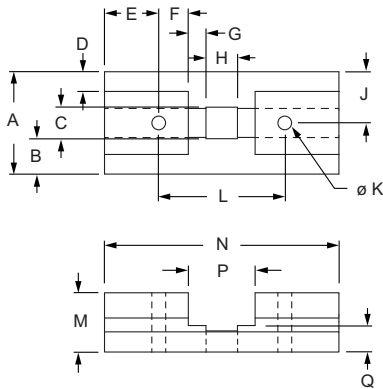

Part No.	Series	Color	A	B	C	D	E	F	G	H	J	K	
6797	10	Natural	.812"	—	—	.156"	.430"	—	—	—	.406"	.109"	
6798	10		.812"	.281"	.250"	.156"	.430"	.235"	.140"	.250"	.406"	.109"	
6897	15		1.250"	—	—	.365"	.656"	—	—	—	.625"	.125"	
6898	15		1.250"	.469"	.312"	.365"	.656"	.369"	.219"	.312"	.625"	.125"	
25-6797	25		20.62mm	—	—	6.35mm	10.85mm	—	—	—	10.31mm	2.77mm	
25-6798	25		20.62mm	7.14mm	6.35mm	6.35mm	10.85mm	5.77mm	3.56mm	6.35mm	10.31mm	2.77mm	
40-6897	40		31.75mm	—	—	9.27mm	17.30mm	—	—	—	15.88mm	3.18mm	
40-6898	40		31.75mm	11.91mm	7.92mm	9.27mm	17.30mm	10.49mm	5.55mm	7.92mm	15.88mm	3.18mm	
			L	M	N	P	Q	R	S	T	U	V	Weight
6797	10		1.000"	.470"	1.860"	—	.210"	.160"	.110"	.200"	50°	.230"	.013 lb
6798	10	1.000"	.470"	1.860"	.530"	.210"	.160"	.110"	.200"	50°	.230"	.012 lb	
6897	15	1.500"	.700"	2.800"	—	.360"	.240"	.195"	.300"	45°	.300"	.046 lb	
6898	15	1.500"	.700"	2.800"	.750"	.360"	.240"	.195"	.300"	45°	.300"	.040 lb	
25-6797	25	25.00mm	11.94mm	46.69mm	—	5.33mm	4.06mm	2.79mm	5.08mm	50°	5.84mm	.0058 kg	
25-6798	25	25.00mm	11.94mm	46.69mm	13.46mm	5.33mm	4.06mm	2.79mm	5.08mm	50°	5.84mm	.0063 kg	
40-6897	40	40.00mm	17.78mm	75.00mm	—	9.14mm	6.10mm	4.95mm	7.62mm	45°	7.62mm	.0222 kg	
40-6898	40	40.00mm	17.78mm	75.00mm	19.05mm	9.14mm	6.10mm	4.95mm	7.62mm	45°	7.62mm	.0195 kg	

Material Specifications

Material	Process	Finish
UHMW PE	Extruded	Smooth

Suggested Hardware (Mount Pad to Bearing Housing)

Part No.	Series	Qty.	Bolt
3625	10	2	#8 x 3/8" Bearing Pad Screw
3628	15	2	#10 x 5/8" Bearing Pad Screw
25-3625	25	2	#8 x 3/8" Bearing Pad Screw
40-3628	40	2	#10 x 5/8" Bearing Pad Screw

Part Description:

The single-keyed UniBearing™ pad is commonly used with a UniBearing™ to create custom bearings. It has a single key and mounts to the profile using stainless steel flathead socket cap screws that have Loctite®. It provides a flat bearing and quick change-out as well as being designed with rounded corners on the molded pad for easy installation. The pad includes holes for mounting the hardware or brake kits as well as all mounting hardware.

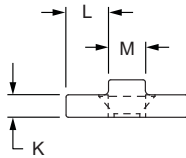
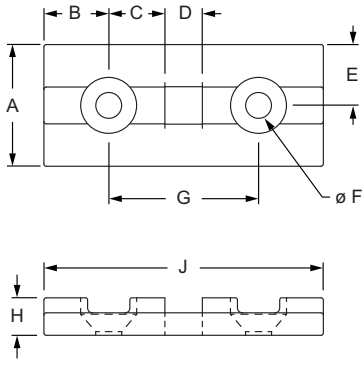

Part No.	Series	Color	A	B	C	D	E	F	G	H	J	K	L	M	Weight
6705	10	White	.812"	.433"	.375"	.246"	.406"	.172"	1.000"	.250"	1.865"	.150"	.283"	.246"	.012 lb
6706	10	Black	.812"	.433"	.375"	.246"	.406"	.172"	1.000"	.250"	1.865"	.150"	.283"	.246"	.012 lb
6814	15	White	1.250"	.635"	.594"	.312"	.625"	.193"	1.500"	.375"	2.770"	.243"	.469"	.312"	.035 lb
6817	15	Black	1.250"	.635"	.594"	.312"	.625"	.193"	1.500"	.375"	2.770"	.243"	.469"	.312"	.035 lb
25-6705	25	White	20.62mm	10.84mm	9.33mm	6.25mm	10.31mm	4.37mm	25.00mm	6.35mm	46.69mm	3.81mm	7.19mm	6.25mm	.0054 kg
25-6706	25	Black	20.62mm	10.84mm	9.33mm	6.25mm	10.31mm	4.37mm	25.00mm	6.35mm	46.69mm	3.81mm	7.19mm	6.25mm	.0054 kg
40-6814	40	Natural	31.75mm	17.06mm	16.04mm	7.92mm	15.88mm	4.90mm	40.00mm	9.53mm	74.12mm	6.17mm	11.91mm	7.92mm	.0172 kg
40-6817	40	Black	31.75mm	17.06mm	16.04mm	7.92mm	15.88mm	4.90mm	40.00mm	9.53mm	74.12mm	6.17mm	11.91mm	7.92mm	.0172 kg

Material Specifications

Part No.	Material	Process	Finish
6705	UHMW PE	Injection Mold	Smooth
6706			
6814			
6817			
25-6705			
25-6706			
40-6814	Extruded		
40-6817			

Included Hardware (Mount Pad to Bearing Housing)

Part No.	Series	Qty.	Bolt
3649*	10 25	2	SS 8-32 x 1/4" FHSCS
3650*	15 40	2	SS 10-24 x 3/8" FHSCS

*Stainless steel (SS) hardware included.

Double-Keyed UniBearing™ Pad

Part Description:

The double-keyed UniBearing™ pad is commonly used with a UniBearing™ to create custom bearings. It has a double key and mounts to a profile using stainless steel flathead socket cap screws. It provides a flat bearing and quick change-out as well as being designed with rounded corners on the molded pad for easy installation.

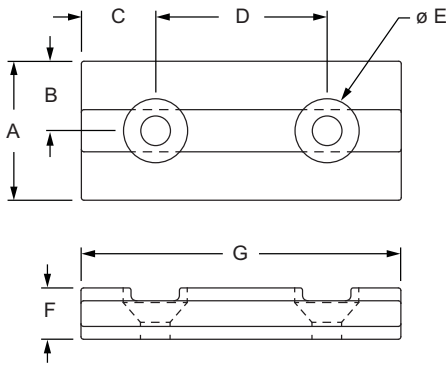

Part No.	Series	Color	A	B	C	D	E	F	G	H	J	K	L	Weight
6792	10	White	.812"	.406"	.433"	1.000"	.172"	.300"	1.865"	.150"	.283"	.246"	.075"	.028 lb
6793	10	Black	.812"	.406"	.433"	1.000"	.172"	.300"	1.865"	.150"	.283"	.246"	.075"	.029 lb
6892	15	White	1.250"	.625"	.635"	1.500"	.258"	.513"	2.770"	.243"	.469"	.312"	.135"	.112 lb
6893	15	Black	1.250"	.625"	.635"	1.500"	.258"	.513"	2.770"	.243"	.469"	.312"	.135"	.112 lb
25-6792	25	White	20.62mm	10.31mm	10.98mm	25.40mm	4.37mm	7.62mm	47.37mm	3.81mm	7.19mm	6.25mm	1.91mm	.0127 kg
25-6793	25	Black	20.62mm	10.31mm	10.98mm	25.40mm	4.37mm	7.62mm	47.37mm	3.81mm	7.19mm	6.25mm	1.91mm	.0127 kg
40-6892	40	Natural	31.75mm	15.88mm	17.06mm	40.00mm	6.55mm	13.03mm	74.12mm	6.17mm	11.91mm	7.92mm	3.43mm	.0326 kg
40-6893	40	Black	31.75mm	15.88mm	17.06mm	40.00mm	6.55mm	13.03mm	74.12mm	6.17mm	11.91mm	7.92mm	3.43mm	.0317 kg

Material Specifications

Part No.	Material	Process	Finish
6792	UHMW PE	Injection Mold	Smooth
6793			
6892			
6893			
25-6792		Extruded	
25-6793			
40-6892			
40-6893			

Included Hardware (Mount Pad to Profile)

Series	Qty.	Bolt	Qty.	T-Nut
10 25	2	673003*	1	3281
15	2	206701*	1	3263
40	2	206701*	1	3686*

*Stainless steel (SS) hardware included.



Part Description:

The single-keyed standard bearing pad profile comes in a stock length of 145" (3686mm) and can be cut to your desired length. It has a key on one side of the pad and is commonly used to create custom bearings for linear motion applications. It is made of easily machined, self-lubricating UHMW, and has a low coefficient of friction. This pad profile is available in black or natural.

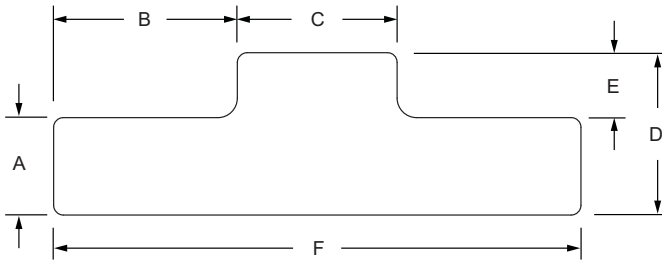

Part No.	Series	Color	A	B	C	D	E	F	Stock Length	Weight
6700	10	Natural	.150"	.283"	.246"	.250"	.100"	.812"	145"	.004 lb / ft
6701	10	Black	.150"	.283"	.246"	.250"	.100"	.812"	145"	.004 lb / ft
6810	15	Natural	.243"	.469"	.312"	.375"	.132"	1.250"	145"	.011 lb / ft
6811	15	Black	.243"	.469"	.312"	.375"	.132"	1.250"	145"	.011 lb / ft
25-6700	25	Natural	3.81mm	7.19mm	6.25mm	6.35mm	2.54mm	20.62mm	3.683 M	.0021 kg / m
25-6701	25	Black	3.81mm	7.19mm	6.25mm	6.35mm	2.54mm	20.62mm	3.683 M	.0021 kg / m
40-6810	40	Natural	6.17mm	11.91mm	7.92mm	9.53mm	3.35mm	31.75mm	3.683 M	.0051 kg / m
40-6811	40	Black	6.17mm	11.91mm	7.92mm	9.53mm	3.35mm	31.75mm	3.683 M	.0051 kg / m

Material Specifications

Material	Process	Finish
UHMW PE	Extruded	Smooth

Required Machining Services

Machining Type	Machined	Reference Page
Cut to Length	Bearing Pad Profile	852

Double-Keyed Standard Bearing Pad Profile

Part Description:

The double-keyed standard bearing pad profile comes in a stock length of 145" (3686mm) and can be cut to your desired length. It has a key on both sides of the pad and is commonly used to create custom bearings for linear motion applications. It is made of easily machined, self-lubricating UHMW, and has a low coefficient of friction. This pad profile is available in black or natural.

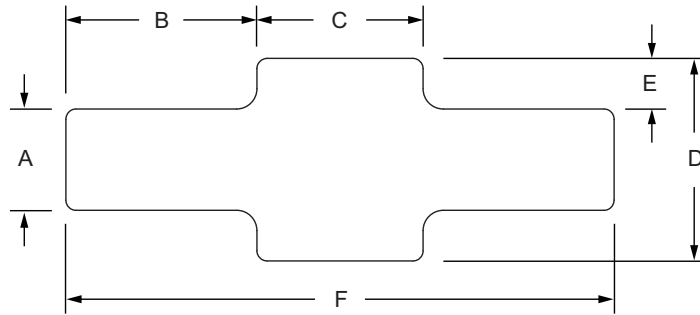

Part No.	Series	Color	A	B	C	D	E	F	Stock Length	Weight
6702	10	Natural	.150"	.283"	.246"	.300"	.075"	.812"	145"	.053 lb / ft
6703	10	Black	.150"	.283"	.246"	.300"	.075"	.812"	145"	.053 lb / ft
6812	15	Natural	.243"	.469"	.312"	.493"	.125"	1.250"	145"	.125 lb / ft
6813	15	Black	.243"	.469"	.312"	.493"	.125"	1.250"	145"	.125 lb / ft
25-6702	25	Natural	3.81mm	7.19mm	6.25mm	7.62mm	1.91mm	20.62mm	3.683 M	.0024 kg / m
25-6703	25	Black	3.81mm	7.19mm	6.25mm	7.62mm	1.91mm	20.62mm	3.683 M	.0024 kg / m
40-6812	40	Natural	6.17mm	11.91mm	7.92mm	12.52mm	3.18mm	31.75mm	3.683 M	.0056 kg / m
40-6813	40	Black	6.17mm	11.91mm	7.92mm	12.52mm	3.18mm	31.75mm	3.683 M	.0056 kg / m

Material Specifications

Material	Process	Finish
UHMW PE	Extruded	Smooth

Required Machining Services

Machining Type	Machined	Reference Page
Cut to Length	Bearing Pad Profile	852

Part Description:

Linear bearing shim stock is used to create a precise fit. Each shim is .005" (.127mm) thick and has a slotted design that enables easy installation without having to dismantle the bearing; simply loosen the bearing pad and slide the shim(s) between the pad and housing while the bearing is still in place. Shims are sold in packs of 10 and are compatible with all 80/20 bearings. See page 658 for more information on shims.

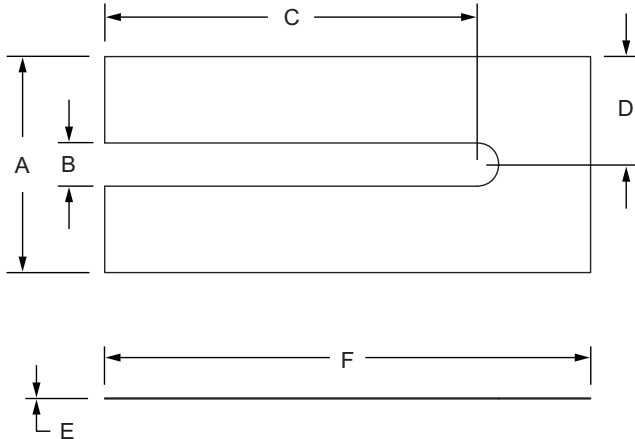

Part No.	Series	Material	Process	Color	A	B	C	D	E	F	Weight
6780	10	Mylar	Cut	Clear	.812"	.175"	1.500"	.406"	.005"	1.875"	.004 lb
6881	15				1.250"	.250"	2.156"	.625"	.005"	2.812"	.011 lb
25-6780	25				20.62mm	4.44mm	38.10mm	10.31mm	.13mm	47.63mm	.0020 kg
40-6881	40				31.75mm	6.35mm	54.76mm	15.88mm	.13mm	71.42mm	.0051kg

“L” Handle Linear Bearing Brake Kit

Part Description:

The “L” handle linear bearing brake kit adds an adjustable stop to any brake-ready bearing by securing it into a semi-permanent position. It also adds a grip to aid with adjustments and provides secure lockdown capability for safety. It's available in black, gray, blue, red, or safety yellow to match your application. All mounting hardware is included.

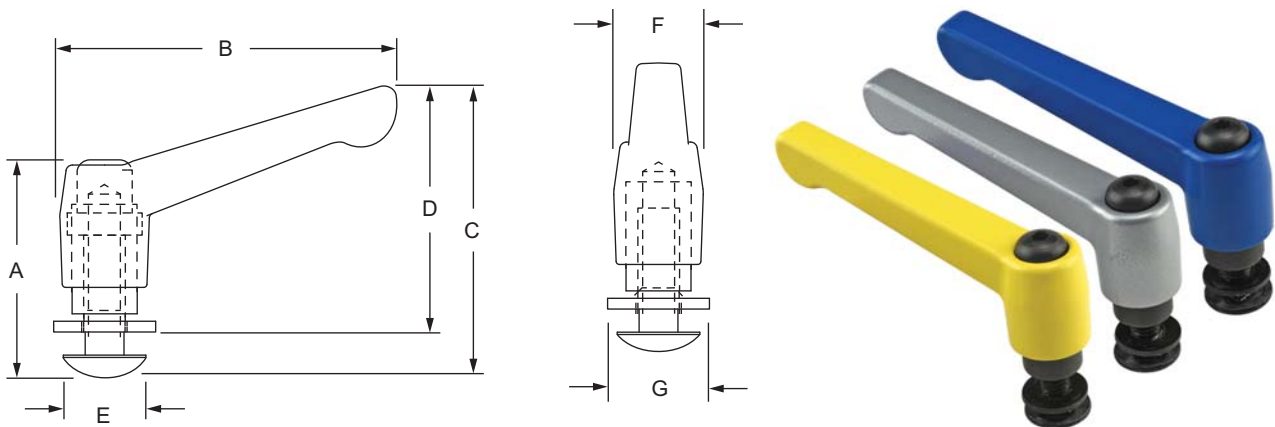

Part No.	Series	Material	Process	Finish	Color	A	B	C	D	E	F	G	Weight
6850	10	Nylon 66	Injection Mold	Matte	Black	1.325"	2.041"	1.745"	1.445"	.500"	.540"	.617"	.048 lb
6800	15	Zinc	Die Cast	Gloss	Gray	2.234"	3.505"	2.985"	2.235"	.703"	.871"	.688"	.336 lb
6805	15	Zinc	Die Cast	Gloss	Blue	2.234"	3.505"	2.985"	2.235"	.703"	.871"	.688"	.336 lb
6806	15	Zinc	Die Cast	Gloss	Red	2.234"	3.505"	2.985"	2.235"	.703"	.871"	.688"	.336 lb
6807	15	Zinc	Die Cast	Gloss	Yellow	2.234"	3.505"	2.985"	2.235"	.703"	.871"	.688"	.336 lb
25-6850	25	Nylon 66	Injection Mold	Matte	Black	33.66mm	51.84mm	44.32mm	36.70mm	12.70mm	13.72mm	15.67mm	.0277 kg
40-6800	40	Zinc	Die Cast	Gloss	Gray	56.74mm	89.03mm	75.82mm	56.77mm	17.86mm	22.12mm	17.48mm	.1524 kg
40-6805	40	Zinc	Die Cast	Gloss	Blue	56.74mm	89.03mm	75.82mm	56.77mm	17.86mm	22.12mm	17.48mm	.1524 kg
40-6806	40	Zinc	Die Cast	Gloss	Red	56.74mm	89.03mm	75.82mm	56.77mm	17.86mm	22.12mm	17.48mm	.1524 kg
40-6807	40	Zinc	Die Cast	Gloss	Yellow	56.74mm	89.03mm	75.82mm	56.77mm	17.86mm	22.12mm	17.48mm	.1524 kg

Part Description:

The "T" handle linear bearing brake kit adds an adjustable stop to any brake-ready bearing by securing it into a semi-permanent position. It also adds a grip to aid with adjustments and provides secure lockdown capability for safety. All mounting hardware is included.

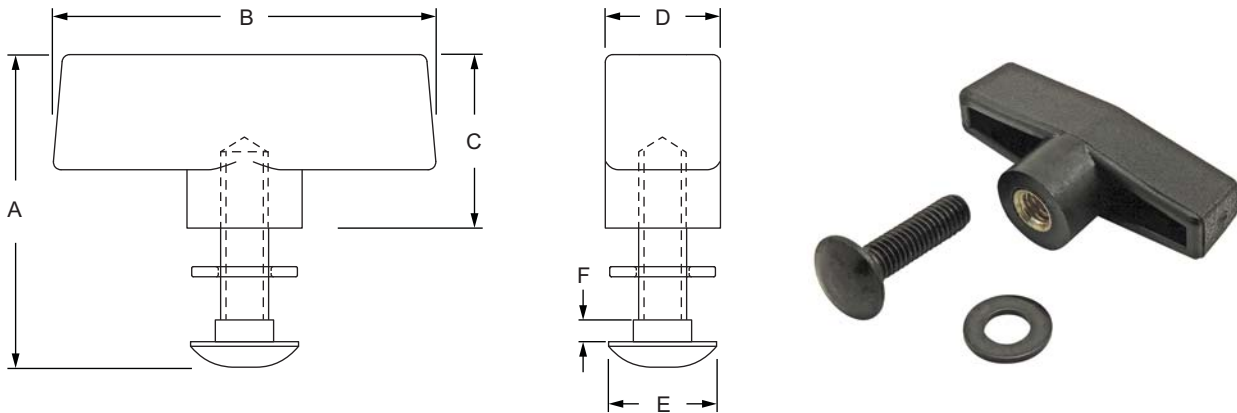

Part No.	Series	Material	Finish	Color	A	B	C	D	E	F	Weight
6801	15	Steel / Polypropylene	Zinc / Matte	Black	2.036"	2.491"	1.130"	.750"	.703"	.150"	.086 lb
40-6801	40				51.71mm	63.27mm	28.70mm	19.05mm	17.86mm	3.81mm	.0390 kg

Hex Nut Linear Bearing Brake Kit



Part Description:

The hex nut linear bearing brake kit adds an adjustable stop to any brake-ready bearing by securing it into a semi-permanent position. It provides secure lockdown capability for safety and is compact, taking up little space. All mounting hardware is included.

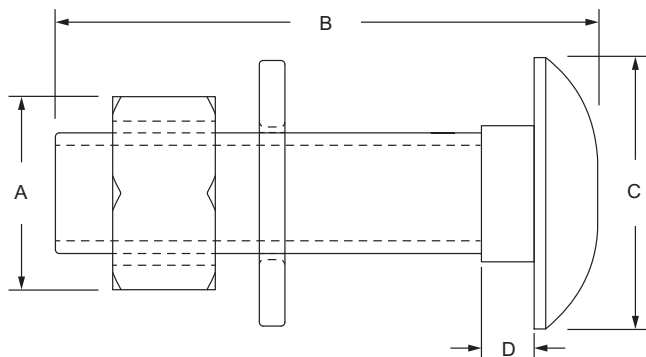

Part No.	Series	Material	Grade	Process	Finish	Color	A	B	C	D	Weight
6851	10	Steel	Grade 5	Formed	Zinc	Black	.438"	.865"	.500"	.150"	.023 lb
6803	15						.500"	1.406"	.703"	.150"	.048 lb
25-6851	25						11.11mm	21.97mm	12.70mm	3.81mm	.0104 kg
40-6803	40						12.70mm	35.71mm	17.86mm	3.81mm	.0217 kg

Part Description:

The wing nut linear bearing brake kit is bright zinc and adds an adjustable stop to any brake-ready bearing by securing it into a semi-permanent position. It provides secure lockdown capability for safety and is compact, taking up little space. All mounting hardware is included.

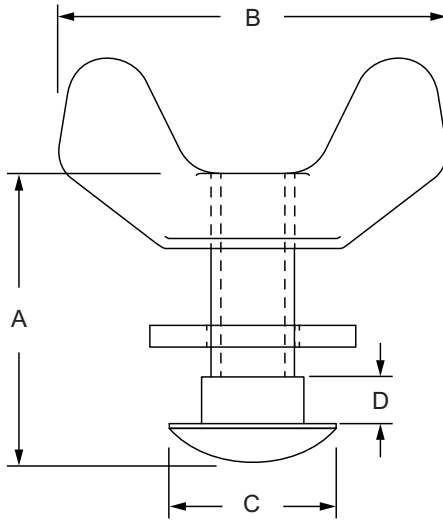

Part No.	Series	Material	Process	Finish	Color	A	B	C	D	Weight
6852	10	Steel	Cold Forged	Zinc	Bright / Black	.865"	1.158"	.500"	.150"	.028 lb
6804	15					1.416"	1.375"	.703"	.150"	.054 lb
25-6852	25					21.97mm	29.41mm	12.70mm	3.81mm	.0127 kg
40-6804	40					35.97mm	34.93mm	17.86mm	3.81mm	.0244 kg

Star Handle Linear Bearing Brake Kit

Part Description:

The star handle linear bearing brake kit adds an adjustable stop to any brake-ready bearing by securing it into a semi-permanent position. It also adds a grip to aid with adjustments and provides secure lockdown capability for safety. All mounting hardware is included.

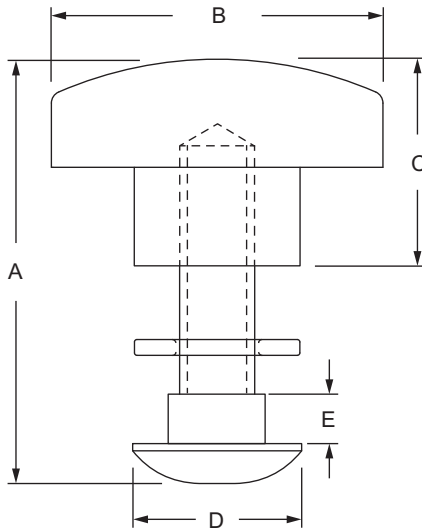

Part No.	Series	Material	Finish	Color	A	B	C	D	E	Weight
6802	15	Steel / Polypropylene	Zinc / Texture	Black	1.766"	1.380"	.860"	.703"	.150"	.069 lb
40-6802	40				44.86mm	35.05mm	21.84mm	17.86mm	3.81mm	.0312 kg

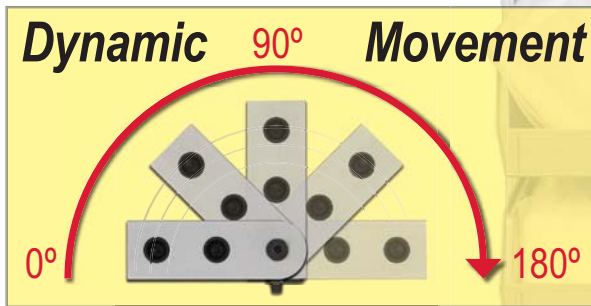

Axial Motion: 0° to 180°

Dynamic pivots are typically used to create axial motion ranging from 0-180 degrees. There are also assemblies available to limit the range of motion from 0-90 degrees. You'll commonly find dynamic pivots in tooling arms, displays and computer stands.



All dynamic arms and brackets come with permanently lubricated bronze bushings for long-lasting and repeated movement.

Dynamic Pivot Components

Dynamic pivot assemblies include a pivot nub and connect to the profile using either "L" arms, straight arms, or brackets. These arms have permanently lubricated bronze bushings that act as a high-strength pivot point and reduce maintenance time and cost.

Repositioning Your Pivot

If you will be repositioning your dynamic pivot frequently, consider adding a handle to help simplify and speed up the process. Dynamic pivots are long-lasting and there are a variety of assembly combinations available that allow you to fold or rotate the profiles to fit your specific needs.



0 Degree Dynamic Pivot Nub

Part Description:

The 0 degree dynamic pivot nub is commonly used as a connection hub for dynamic pivots to create full axial motion ranging from 0-180 degrees parallel to the mounting profile. The 0 degree dynamic pivot nub requires no machining services and can be easily assembled, lending itself to repositioning and reuse. The hardware to mount the nub to a profile is included while the suggested mounting hardware to attach the arm to the nub can be found below.

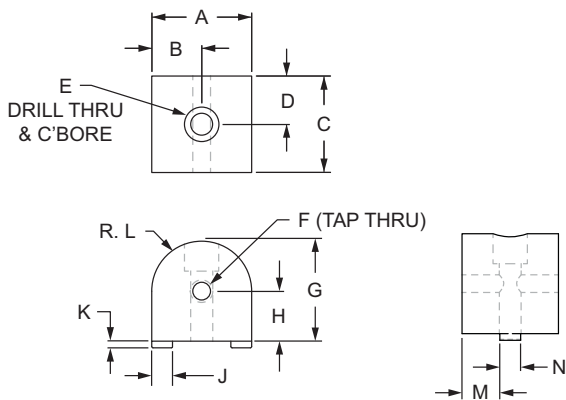

Part No.	Series	Color	A	B	C	D	E	F	G	H	J	K	L	M	N	Weight
4181	10	Clear	1.000"	.500"	.950"	.475"	1/4-20	1/4-20	1.000"	.500"	.245"	.060"	.500"	.353"	.245"	.096 lb
4181-Black	10	Black	1.000"	.500"	.950"	.475"	1/4-20	1/4-20	1.000"	.500"	.245"	.060"	.500"	.353"	.245"	.096 lb
4381	15	Clear	1.500"	.750"	1.448"	.724"	5/16-18	5/16-18	1.500"	.750"	.312"	.100"	.750"	.568"	.312"	.312 lb
4381-Black	15	Black	1.500"	.750"	1.448"	.724"	5/16-18	5/16-18	1.500"	.750"	.312"	.100"	.750"	.568"	.312"	.312 lb
25-4181	25	Clear	25.00mm	12.50mm	23.72mm	11.86mm	M6 x 1.0	M6 x 1.0	25.00mm	12.50mm	6.30mm	1.09mm	12.50mm	8.71mm	6.30mm	.0428 kg
25-4181-Black	25	Black	25.00mm	12.50mm	23.72mm	11.86mm	M6 x 1.0	M6 x 1.0	25.00mm	12.50mm	6.30mm	1.09mm	12.50mm	8.71mm	6.30mm	.0428 kg
40-4381	40	Clear	40.00mm	20.00mm	38.71mm	19.36mm	M8 x 1.25	M8 x 1.25	40.00mm	20.00mm	7.92mm	2.50mm	20.00mm	11.44mm	7.92mm	.1655 kg
40-4381-Black	40	Black	40.00mm	20.00mm	38.71mm	19.36mm	M8 x 1.25	M8 x 1.25	40.00mm	20.00mm	7.92mm	2.50mm	20.00mm	11.44mm	7.92mm	.1655 kg

Material Specifications

Material	Alloy*	Finish
Aluminum	6105-T5	Anodize

* Or comparable

Included Hardware (Mount Nub to T-Slot)

Part No.	Series	Qty.	Bolt	T-Nut
3306	10	1	1/4-20 x 1" SHCS	Economy
3613	15	1	5/16-18 x 1.5" SHCS	
75-3415	25	1	M6 x 25mm SHCS	
75-3479	40	1	M8 x 40mm SHCS	

Suggested Hardware (Mount Arm to Nub)

Part No.	Series	Qty.	Bolt Assembly
3501	10	1	5/16 x 1/4" Shoulder Bolt & Thrust Washer
3500	15	1	3/8 x 3/8" Shoulder Bolt & Thrust Washer
25-3501	25	1	6mm x 6mm Shoulder Bolt & Thrust Washer
40-3500	40	1	10mm x 10mm Shoulder Bolt & Thrust Washer

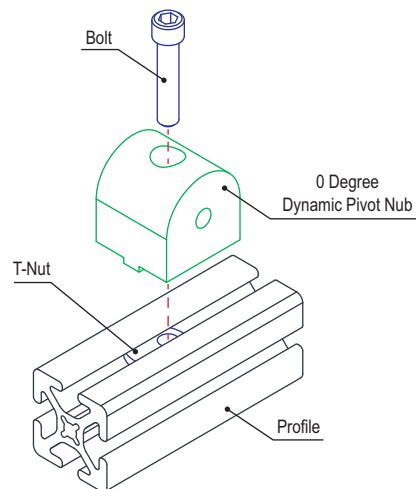

Part Description:

The 90 degree dynamic pivot nub is commonly used as a connection hub for dynamic pivots to create full axial motion ranging from 0-180 degrees perpendicular to the mounting profile. The 90 degree dynamic pivot nub requires no machining services and can be easily assembled, lending itself to repositioning and reuse. The hardware to mount the nub to a profile is included while the suggested mounting hardware to attach the arm to the nub can be found below.

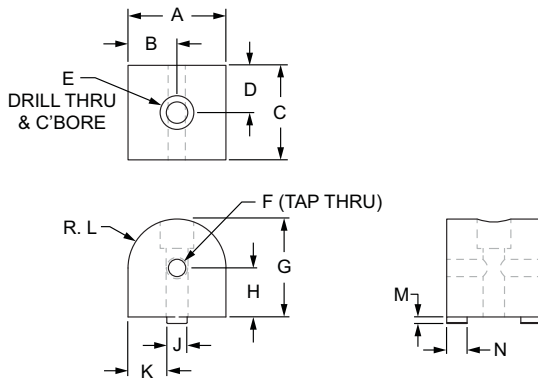

Part No.	Series	Color	A	B	C	D	E	F	G	H	J	K	L	M	N	Weight
4184	10	Clear	1.000"	.500"	.950"	.475"	1/4-20	1/4-20	1.000"	.500"	.245"	.377"	.500"	.060"	.211"	.095 lb
4184-Black	10	Black	1.000"	.500"	.950"	.475"	1/4-20	1/4-20	1.000"	.500"	.245"	.377"	.500"	.060"	.211"	.095 lb
4384	15	Clear	1.500"	.750"	1.448"	.724"	5/16-18	5/16-18	1.500"	.750"	.312"	0.594"	.750"	.100"	.312"	.311 lb
4384-Black	15	Black	1.500"	.750"	1.448"	.724"	5/16-18	5/16-18	1.500"	.750"	.312"	0.594"	.750"	.100"	.312"	.311 lb
25-4184	25	Clear	25.00mm	12.50mm	23.72mm	11.86mm	M6 x 1.0	M6 x 1.0	25.00mm	12.50mm	6.30mm	9.35mm	12.50mm	1.09mm	5.50mm	.0431 kg
25-4184-Black	25	Black	25.00mm	12.50mm	23.72mm	11.86mm	M6 x 1.0	M6 x 1.0	25.00mm	12.50mm	6.30mm	9.35mm	12.50mm	1.09mm	5.50mm	.0431 kg
40-4384	40	Clear	40.00mm	20.00mm	38.71mm	19.36mm	M8 x 1.25	M8 x 1.25	40.00mm	20.00mm	7.92mm	16.04mm	20.00mm	2.50mm	7.92mm	1.655 kg
40-4384-Black	40	Black	40.00mm	20.00mm	38.71mm	19.36mm	M8 x 1.25	M8 x 1.25	40.00mm	20.00mm	7.92mm	16.04mm	20.00mm	2.50mm	7.92mm	1.655 kg

Material Specifications

Material	Alloy*	Finish
Aluminum	6105-T5	Anodize

* Or comparable

Included Hardware (Mount Nub to T-Slot)

Part No.	Series	Qty.	Bolt	T-Nut
3306	10	1	1/4-20 x 1" SHCS	Economy
3613	15	1	5/16-18 x 1.5" SHCS	
75-3415	25	1	M6 x 25mm SHCS	
75-3479	40	1	M8 x 40mm SHCS	

Suggested Hardware (Mount Arm to Nub)

Part No.	Series	Qty.	Bolt Assembly
3501	10	1	5/16 x 1/4" Shoulder Bolt & Thrust Washer
3500	15	1	3/8 x 3/8" Shoulder Bolt & Thrust Washer
25-3501	25	1	6mm x 6mm Shoulder Bolt & Thrust Washer
40-3500	40	1	10mm x 10mm Shoulder Bolt & Thrust Washer

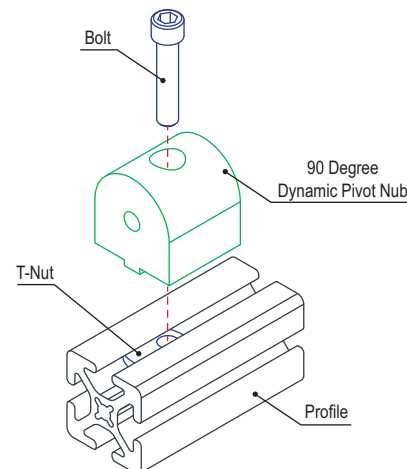

Universal Dynamic Pivot Nub

Part Description:

The universal dynamic pivot nub is commonly used to create either a perpendicular or parallel dynamic pivot with full axial motion ranging from 0-180 degrees. The universal pivot nub requires no machining and can be easily assembled, lending itself to repositioning and reuse. The hardware to mount the nub to a profile is included while the suggested mounting hardware to attach the arm to the nub can be found below.

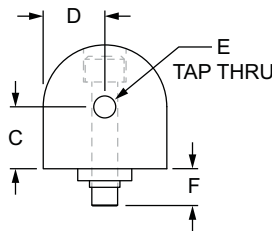
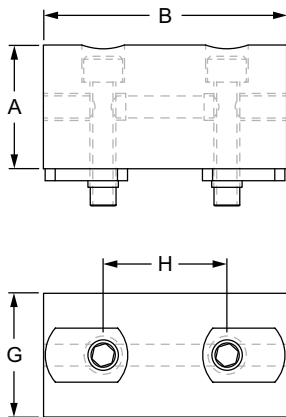

Part No.	Series	Color	A	B	C	D	E	F	G	H	Weight
4177	10	Clear	1.000"	1.950"	.500"	.500"	1/4-20	.275"	1.000"	1.000"	.200 lb
4177-Black	10	Black	1.000"	1.950"	.500"	.500"	1/4-20	.275"	1.000"	1.000"	.200 lb
4377	15	Clear	1.500"	2.948"	.750"	.750"	5/16-18	.450"	1.500"	1.500"	.635 lb
4377-Black	15	Black	1.500"	2.948"	.750"	.750"	5/16-18	.450"	1.500"	1.500"	.635 lb
25-4177	25	Clear	25.00mm	48.69mm	12.50mm	12.50mm	M6 x 1.0	6.88mm	25.00mm	25.00mm	.0871 kg
25-4177-Black	25	Black	25.00mm	48.69mm	12.50mm	12.50mm	M6 x 1.0	6.88mm	25.00mm	25.00mm	.0871 kg
40-4377	40	Clear	40.00mm	78.69mm	20.00mm	20.00mm	M8 x 1.25	11.43mm	40.00mm	40.00mm	.3344 kg
40-4377-Black	40	Black	40.00mm	78.69mm	20.00mm	20.00mm	M8 x 1.25	11.43mm	40.00mm	40.00mm	.3344 kg

Material Specifications

Material	Alloy*	Finish
Aluminum	6105-T5	Anodize

* Or comparable

Included Hardware (Mount Nub to T-Slot)

Part No.	Series	Qty.	Bolt	T-Nut
3306	10	2	1/4-20 x 1" SHCS	Economy
3613	15	2	5/16-18 x 1.5" SHCS	
75-3415	25	2	M6 x 25mm SHCS	
75-3480	40	2	M8 x 40mm SHCS	

Suggested Hardware (Mount Arm to Nub)

Part No.	Series	Qty.	Bolt Assembly
3501	10	1	5/16 x 1/4" Shoulder Bolt & Thrust Washer
3500	15	1	3/8 x 3/8" Shoulder Bolt & Thrust Washer
25-3501	25	1	6mm x 6mm Shoulder Bolt & Thrust Washer
40-3500	40	1	10mm x 10mm Shoulder Bolt & Thrust Washer

Part Description:

The 0 degree dynamic right angle pivot nub is commonly used as a connection hub for dynamic pivots to create axial motion ranging from 0-90 degrees parallel to the mounting profile. This pivot nub requires no machining services and can be easily assembled, lending itself to repositioning and reuse. The hardware to mount the nub to a profile is included while the suggested mounting hardware to attach the arm to the nub can be found below.

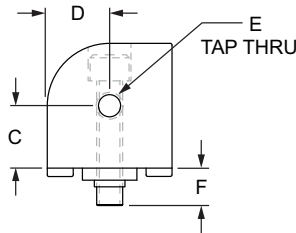
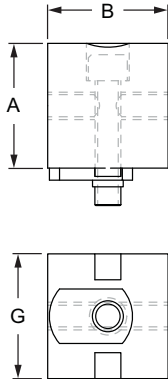

Part No.	Series	Color	A	B	C	D	E	F	G	Weight
4025	10	Clear	1.000"	.950"	.500"	.500"	1/4-20	.275"	1.000"	.102 lb
4025-Black	10	Black	1.000"	.950"	.500"	.500"	1/4-20	.275"	1.000"	.102 lb
4425	15	Clear	1.500"	1.448"	.750"	.750"	5/16-18	.450"	1.500"	.330 lb
4425-Black	15	Black	1.500"	1.448"	.750"	.750"	5/16-18	.450"	1.500"	.330 lb
25-4025	25	Clear	25.00mm	23.72mm	12.50mm	12.50mm	M6 x 1.0	6.88mm	25.00mm	.0450 kg
25-4025-Black	25	Black	25.00mm	23.72mm	12.50mm	12.50mm	M6 x 1.0	6.88mm	25.00mm	.0450 kg
40-4425	40	Clear	40.00mm	38.71mm	20.00mm	20.00mm	M8 x 1.25	11.43mm	40.00mm	.1736 kg
40-4425-Black	40	Black	40.00mm	38.71mm	20.00mm	20.00mm	M8 x 1.25	11.43mm	40.00mm	.1736 kg

Material Specifications

Material	Alloy*	Finish
Aluminum	6105-T5	Anodize

* Or comparable

Included Hardware (Mount Nub to T-Slot)

Part No.	Series	Qty.	Bolt	T-Nut
3306	10	1	1/4-20 x 1" SHCS	Economy
3613	15	1	5/16-18 x 1.5" SHCS	
75-3415	25	1	M6 x 25mm SHCS	
75-3479	40	1	M8 x 40mm SHCS	

Suggested Hardware (Mount Arm to Nub)

Part No.	Series	Qty.	Bolt Assembly
3501	10	1	5/16 x 1/4" Shoulder Bolt & Thrust Washer
3500	15	1	3/8 x 3/8" Shoulder Bolt & Thrust Washer
25-3501	25	1	6mm x 6mm Shoulder Bolt & Thrust Washer
40-3500	40	1	10mm x 10mm Shoulder Bolt & Thrust Washer

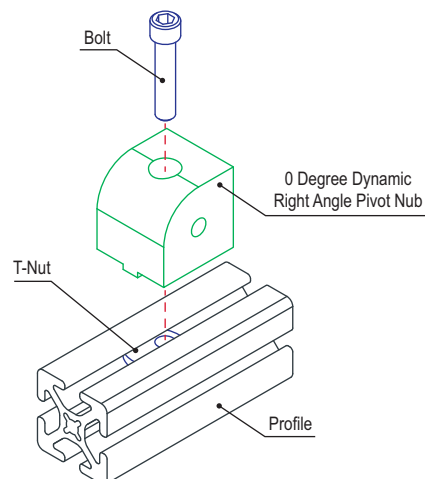

90 Degree Dynamic Right Angle Pivot Nub

Part Description:

The 90 degree dynamic right angle pivot nub is commonly used as a connection hub for dynamic pivots to create full axial motion ranging from 0-90 degrees perpendicular to the mounting profile. This pivot nub requires no machining services and can be easily assembled, lending itself to repositioning and reuse. The hardware to mount the nub to a profile is included while the suggested mounting hardware to attach the arm to the nub can be found below.

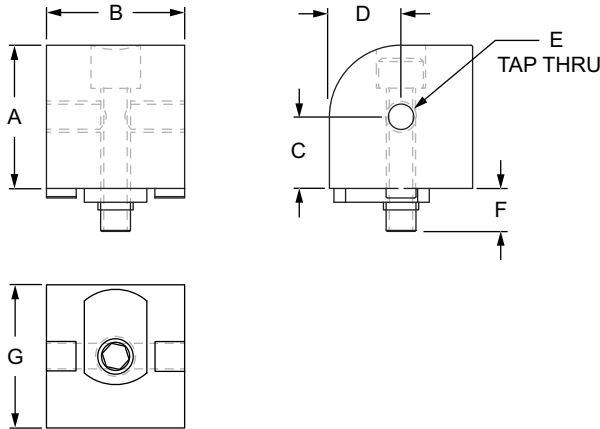

Part No.	Series	Color	A	B	C	D	E	F	G	Weight
4026	10	Clear	1.000"	.950"	.500"	.500"	1/4-20	.275"	1.000"	.102 lb
4026-Black	10	Black	1.000"	.950"	.500"	.500"	1/4-20	.275"	1.000"	.102 lb
4426	15	Clear	1.500"	1.448"	.750"	.750"	5/16-18	.450"	1.500"	.328 lb
4426-Black	15	Black	1.500"	1.448"	.750"	.750"	5/16-18	.450"	1.500"	.328 lb
25-4026	25	Clear	25.00mm	23.72mm	12.50mm	12.50mm	M6 x 1.0	6.88mm	25.00mm	.0450 kg
25-4026-Black	25	Black	25.00mm	23.72mm	12.50mm	12.50mm	M6 x 1.0	6.88mm	25.00mm	.0450 kg
40-4426	40	Clear	40.00mm	38.71mm	20.00mm	20.00mm	M8 x 1.25	11.43mm	40.00mm	.1742 kg
40-4426-Black	40	Black	40.00mm	38.71mm	20.00mm	20.00mm	M8 x 1.25	11.43mm	40.00mm	.1742 kg

Material Specifications

Material	Alloy*	Finish
Aluminum	6105-T5	Anodize

* Or comparable

Included Hardware (Mount Nub to T-Slot)

Part No.	Series	Qty.	Bolt	T-Nut
3306	10	1	1/4-20 x 1" SHCS	Economy
3613	15	1	5/16-18 x 1.5" SHCS	
75-3415	25	1	M6 x 25mm SHCS	
75-3479	40	1	M8 x 40mm SHCS	

Suggested Hardware (Mount Arm to Nub)

Part No.	Series	Qty.	Bolt Assembly
3501	10	1	5/16 x 1/4" Shoulder Bolt & Thrust Washer
3500	15	1	3/8 x 3/8" Shoulder Bolt & Thrust Washer
25-3501	25	1	6mm x 6mm Shoulder Bolt & Thrust Washer
40-3500	40	1	10mm x 10mm Shoulder Bolt & Thrust Washer

Part Description:

The universal dynamic right angle pivot nub is commonly used to create either a perpendicular or parallel dynamic pivot with full axial motion ranging from 0-90 degrees. The universal pivot nub requires no machining and can be easily assembled, lending itself to repositioning and reuse. The hardware to mount the nub to a profile is included while the suggested mounting hardware to attach the arm to the nub can be found below.

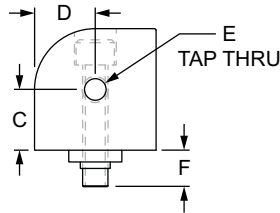
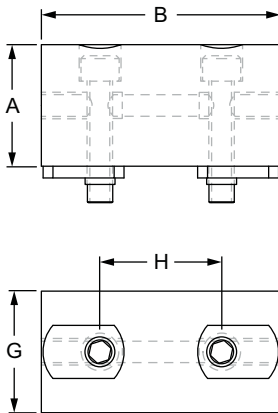

Part No.	Series	Color	A	B	C	D	E	F	G	H	Weight
4027	10	Clear	1.000"	1.950"	.500"	.500"	1/4-20	.275"	1.000"	1.000"	.20 lb
4027-Black	10	Black	1.000"	1.950"	.500"	.500"	1/4-20	.275"	1.000"	1.000"	.20 lb
4427	15	Clear	1.500"	2.948"	.750"	.750"	5/16-18	.450"	1.500"	1.500"	.672 lb
4427-Black	15	Black	1.500"	2.948"	.750"	.750"	5/16-18	.450"	1.500"	1.500"	.672 lb
25-4027	25	Clear	25.00mm	48.69mm	12.50mm	12.50mm	M6 x 1.0	6.88mm	25.00mm	25.00mm	.091 kg
25-4027-Black	25	Black	25.00mm	48.69mm	12.50mm	12.50mm	M6 x 1.0	6.88mm	25.00mm	25.00mm	.091 kg
40-4427	40	Clear	40.00mm	78.69mm	20.00mm	20.00mm	M8 x 1.25	11.43mm	40.00mm	40.00mm	.3503 kg
40-4427-Black	40	Black	40.00mm	78.69mm	20.00mm	20.00mm	M8 x 1.25	11.43mm	40.00mm	40.00mm	.3503 kg

Material Specifications

Material	Alloy*	Finish
Aluminum	6105-T5	Anodize

* Or comparable

Included Hardware (Mount Nub to T-Slot)

Part No.	Series	Qty.	Bolt	T-Nut
3306	10	2	1/4-20 x 1" SHCS	Economy
3613	15	2	5/16-18 x 1.5" SHCS	
75-3415	25	2	M6 x 25mm SHCS	
75-3480	40	2	M8 x 40mm SHCS	

Suggested Hardware (Mount Arm to Nub)

Part No.	Series	Qty.	Bolt Assembly
3501	10	1	5/16 x 1/4" Shoulder Bolt & Thrust Washer
3500	15	1	3/8 x 3/8" Shoulder Bolt & Thrust Washer
25-3501	25	1	6mm x 6mm Shoulder Bolt & Thrust Washer
40-3500	40	1	10mm x 10mm Shoulder Bolt & Thrust Washer

“L” Dynamic Pivot Arm

Part Description:

The “L” dynamic pivot arm is commonly used in assemblies to create a dynamic pivot; it provides a long-lasting connection and requires no machining services. The pivot arm can be easily assembled, lending itself to repositioning and reuse and has a permanently lubricated bronze bushing that acts as high-strength pivot point. The hardware to mount the pivot arm to the profile is included while the suggested hardware to connect the pivot arm to the nub can be found below. **Tip:** Pre-load your hardware prior to connecting profiles to simplify your assembly and save time.

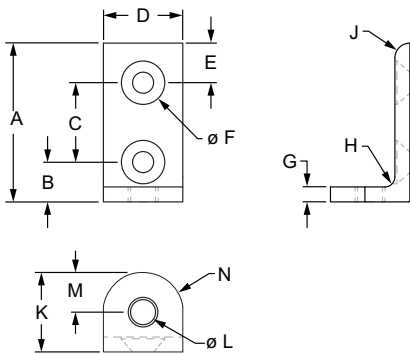

Part No.	Series	Color	A	B	C	D	E	F	G	H	J	K	L	M	N	Weight
4172	10	Clear	2.000"	.500"	1.000"	1.000"	.500"	.257"	.188"	.125"	.188"	1.000"	.312"	.500"	.505"	.079 lb
4172-Black	10	Black	2.000"	.500"	1.000"	1.000"	.500"	.257"	.188"	.125"	.188"	1.000"	.312"	.500"	.505"	.079 lb
4343	15	Clear	3.000"	.750"	1.500"	1.500"	.750"	.328"	.250"	.312"	.250"	1.500"	.375"	.750"	.755"	.215 lb
4343-Black	15	Black	3.000"	.750"	1.500"	1.500"	.750"	.328"	.250"	.312"	.250"	1.500"	.375"	.750"	.755"	.215 lb
25-4172	25	Clear	50.00mm	12.50mm	25.00mm	25.00mm	12.50mm	6.23mm	4.00mm	3.00mm	4.00mm	25.00mm	8.00mm	12.50mm	12.50mm	.0471 kg
25-4172-Black	25	Black	50.00mm	12.50mm	25.00mm	25.00mm	12.50mm	6.23mm	4.00mm	3.00mm	4.00mm	25.00mm	8.00mm	12.50mm	12.50mm	.0471 kg
40-4343	40	Clear	80.00mm	20.00mm	40.00mm	40.00mm	20.00mm	8.13mm	6.00mm	8.00mm	6.00mm	40.00mm	10.00mm	20.00mm	19.91mm	.1002 kg
40-4343-Black	40	Black	80.00mm	20.00mm	40.00mm	40.00mm	20.00mm	8.13mm	6.00mm	8.00mm	6.00mm	40.00mm	10.00mm	20.00mm	19.91mm	.1002 kg

Material Specifications

Material	Alloy*	Finish
Aluminum	6105-T5	Anodize

* Or comparable

Included Hardware (Mount Arm to T-Slot)

Part No.	Series	Qty.	Bolt	T-Nut
3414	10	2	1/4-20 x 1/2" FHSCS	Economy
3412	15	2	5/16-18 x 5/8" FHSCS	
75-3541	25	2	M6 x 10mm FHSCS	
75-3508	40	2	M8 x 16mm FHSCS	

Suggested Hardware (Mount Arm to Nub)

Part No.	Series	Qty.	Bolt Assembly
3501	10	1	5/16 x 1/4" Shoulder Bolt & Thrust Washer
3500	15	1	3/8 x 3/8" Shoulder Bolt & Thrust Washer
25-3501	25	1	6mm x 6mm Shoulder Bolt & Thrust Washer
40-3500	40	1	10mm x 10mm Shoulder Bolt & Thrust Washer

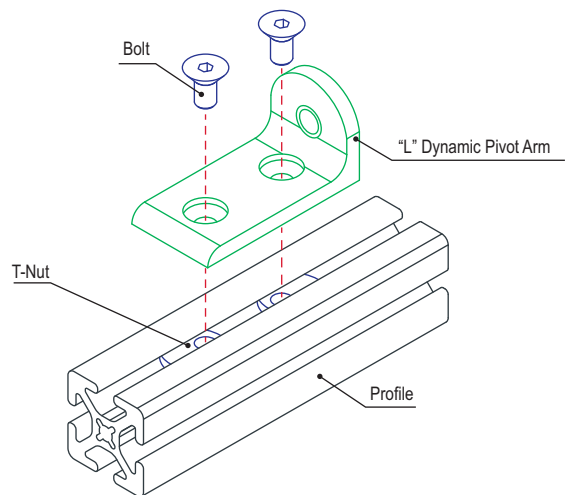

Part Description:

The standard straight dynamic pivot arm is typically used to create a dynamic pivot between profiles; it provides a long-lasting connection and requires no machining services. The pivot arm can be easily assembled, lending itself to repositioning and reuse and has a permanently lubricated bronze bushing that acts as a high-strength pivot point. The hardware to mount the pivot arm to the profile is included while the suggested hardware to connect the pivot arm to the nub can be found below. **Tip:** Pre-load your hardware prior to connecting profiles to simplify your assembly and save time.

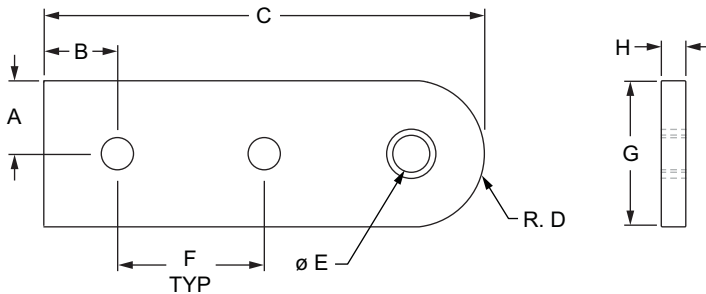

Part No.	Series	Color	A	B	C	D	E	F	G	H	Weight
4185	10	Clear	.500"	.500"	3.000"	.505"	.373"	1.000"	1.000"	.188"	.089 lb
4185-Black	10	Black	.500"	.500"	3.000"	.505"	.373"	1.000"	1.000"	.188"	.089 lb
4385	15	Clear	.745"	.750"	4.495"	.750"	.500"	1.500"	1.490"	.250"	.254 lb
4385-Black	15	Black	.745"	.750"	4.495"	.750"	.500"	1.500"	1.490"	.250"	.254 lb
25-4185	25	Clear	12.50mm	12.50mm	75.00mm	12.50mm	10.00mm	25.00mm	25.00mm	4.00mm	.0340 kg
25-4185-Black	25	Black	12.50mm	12.50mm	75.00mm	12.50mm	10.00mm	25.00mm	25.00mm	4.00mm	.0340 kg
40-4385	40	Clear	20.00mm	20.00mm	120.00mm	20.00mm	14.00mm	40.00mm	40.00mm	6.35mm	.1177 kg
40-4385-Black	40	Black	20.00mm	20.00mm	120.00mm	20.00mm	14.00mm	40.00mm	40.00mm	6.35mm	.1177 kg

Material Specifications

Material	Alloy*	Finish
Aluminum	6105-T5	Anodize

* Or comparable

Included Hardware (Mount Arm to T-Slot)

Part No.	Series	Qty.	Bolt	T-Nut
3356	10	2	1/4-20 x 1/2" FBHSCS	Double Economy
3355	15	2	5/16-18 x 11/16" SHCS	
75-3509	25	2	M6 x 10mm BHSCS	
75-3513	40	2	M8 x 16mm BHSCS	

Suggested Hardware (Mount Arm to Nub)

Part No.	Series	Qty.	Bolt Assembly
3501	10	1	5/16 x 1/4" Shoulder Bolt & Thrust Washer
3500	15	1	3/8 x 3/8" Shoulder Bolt & Thrust Washer
25-3501	25	1	6mm x 6mm Shoulder Bolt & Thrust Washer
40-3500	40	1	10mm x 10mm Shoulder Bolt & Thrust Washer

Standard 0 Degree Dynamic Pivot Assembly with Dual Straight Arms

Part Description:

The standard 0 degree dynamic pivot assembly with dual straight arms is typically used to create dynamic pivots that are parallel to the mounting profile and have full axial motion ranging from 0-180 degrees. The assembly includes one 0 degree dynamic pivot nub and two standard straight dynamic pivot arms. It has permanently lubricated bronze bushings that act as high-strength pivot points and nylon thrust washers that protect the pivot arms. This assembly offers a high load capacity while ensuring a long life cycle. A shim kit and the hardware to connect the nub to the profile, the nub to the arms, and the arms to the profile are all included.

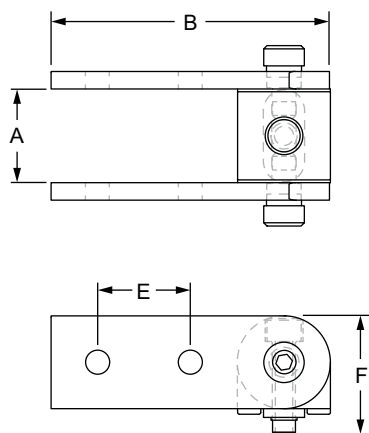

Part No.	Series	Nub (Qty.)	Arm (Qty.)	Color	A	B	C	D	E	F	Weight
4180	10	4181 (1)	4185 (2)	Clear	1.010"	3.010"	1.858"	1.000"	1.000"	1.275"	.315 lb
4180-Black	10	4181 (1)	4185 (2)	Black	1.010"	3.010"	1.858"	1.000"	1.000"	1.275"	.315 lb
4380	15	4381 (1)	4385 (2)	Clear	1.512"	4.500"	2.313"	1.500"	1.500"	1.950"	.883 lb
4380-Black	15	4381 (1)	4385 (2)	Black	1.512"	4.500"	2.313"	1.500"	1.500"	1.950"	.883 lb
25-4180	25	25-4181 (1)	25-4185 (2)	Clear	25.24mm	75.00mm	47.78mm	25.00mm	25.00mm	31.88mm	.1279 kg
25-4180-Black	25	25-4181 (1)	25-4185 (2)	Black	25.24mm	75.00mm	47.78mm	25.00mm	25.00mm	31.88mm	.1279 kg
40-4380	40	40-4381 (1)	40-4385 (2)	Clear	40.33mm	120.00mm	74.68mm	40.00mm	40.00mm	51.43mm	.4500 kg
40-4380-Black	40	40-4381 (1)	40-4385 (2)	Black	40.33mm	120.00mm	74.68mm	40.00mm	40.00mm	51.43mm	.4500 kg

Material Specifications

Material	Alloy*	Finish
Aluminum	6105-T5	Anodize

* Or comparable

Included Mounting Hardware

Series	Nub to Profile		Arms to Nub		Arms to Profile	
	Part No.	Qty.	Part No.	Qty.	Part No.	Qty.
10	3306	1	3501	1	3356	2
15	3613	1	3500	1	3355	2
25	75-3415	1	25-3501	1	75-3509	2
40	75-3479	1	40-3500	1	75-3513	2

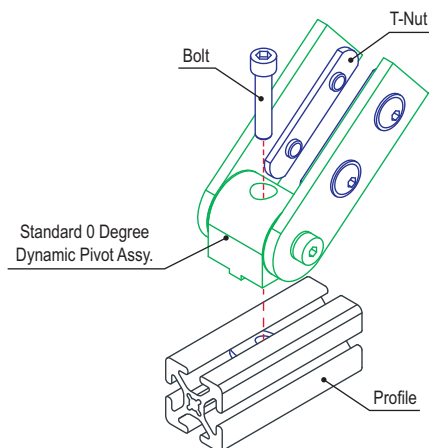

Standard 90 Degree Dynamic Pivot Assembly with Dual Straight Arms

Part Description:

The standard 90 degree dynamic pivot assembly with dual straight arms is typically used to create dynamic pivots that are perpendicular to the mounting profile and have full axial motion ranging from 0-180 degrees. The assembly includes one 90 degree dynamic pivot nub and two standard straight dynamic pivot arms. It has permanently lubricated bronze bushings that act as high-strength pivot points and nylon thrust washers that protect the arms. This assembly offers a high load capacity while ensuring a long life cycle. A shim kit and the hardware to connect the nub to the profile, the nub to the arms, and the arms to the profile are included.

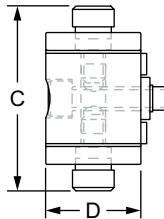
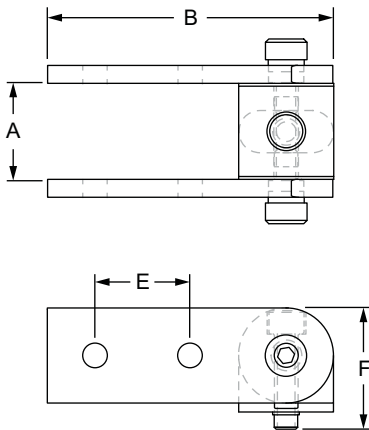

Part No.	Series	Nub (Qty.)	Arm (Qty.)	Color	A	B	C	D	E	F	Weight
4183	10	4184 (1)	4185 (2)	Clear	1.010"	3.010"	1.858"	1.000"	1.000"	1.275"	.314 lb
4183-Black	10	4184 (1)	4185 (2)	Black	1.010"	3.010"	1.858"	1.000"	1.000"	1.275"	.314 lb
4383	15	4381 (1)	4385 (2)	Clear	1.512"	4.500"	2.313"	1.500"	1.500"	1.950"	.889 lb
4383-Black	15	4381 (1)	4385 (2)	Black	1.512"	4.500"	2.313"	1.500"	1.500"	1.950"	.889 lb
25-4183	25	25-4184 (1)	25-4185 (2)	Clear	25.24mm	75.00mm	47.78mm	25.00mm	25.00mm	31.88mm	.1109 kg
25-4183-Black	25	25-4184 (1)	25-4185 (2)	Black	25.24mm	75.00mm	47.78mm	25.00mm	25.00mm	31.88mm	.1109 kg
40-4383	40	40-4381 (1)	40-4385 (2)	Clear	40.33mm	120.00mm	74.68mm	40.00mm	40.00mm	51.43mm	.4475 kg
40-4383-Black	40	40-4381 (1)	40-4385 (2)	Black	40.33mm	120.00mm	74.68mm	40.00mm	40.00mm	51.43mm	.4475 kg

Material Specifications

Material	Alloy*	Finish
Aluminum	6105-T5	Anodize

* Or comparable

Included Mounting Hardware

Series	Nub to Profile		Arms to Nub		Arms to Profile	
	Part No.	Qty.	Part No.	Qty.	Part No.	Qty.
10	3306	1	3501	1	3356	2
15	3613	1	3500	1	3355	2
25	75-3415	1	25-3501	1	75-3509	2
40	75-3479	1	40-3500	1	75-3513	2

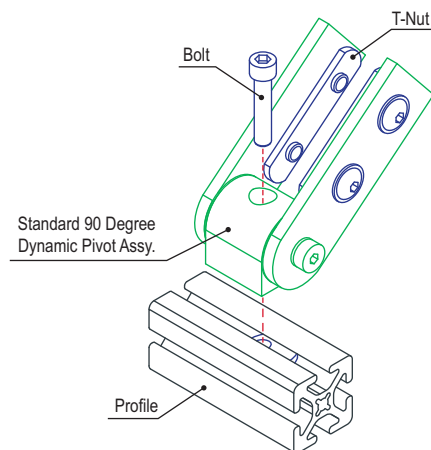

Standard Universal Dynamic Pivot Assembly with Dual Straight Arms

Part Description:

The standard universal dynamic pivot assembly with dual straight arms is typically used to create either a perpendicular or parallel dynamic pivot with full axial motion ranging from 0-180 degrees. The assembly includes one universal dynamic pivot nub and two standard straight dynamic pivot arms. It has permanently lubricated bronze bushings that act as high-strength pivot points and nylon thrust washers that protect the pivot arms. This assembly offers a high load capacity while ensuring a long life cycle. A shim kit and the hardware to connect the nub to the profile, the nub to the arms, and the arms to the profile are all included.

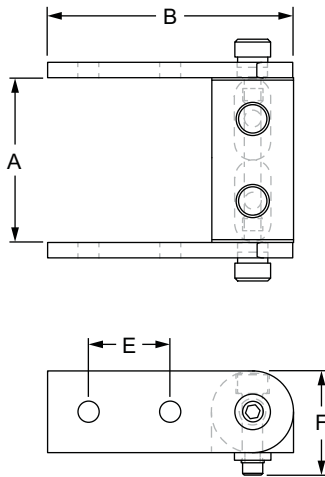

Part No.	Series	Nub (Qty.)	Arm (Qty.)	Color	A	B	C	D	E	F	Weight
4178	10	4177 (1)	4185 (2)	Clear	2.010"	3.010"	2.858"	1.000"	1.000"	1.275"	.409 lb
4178-Black	10	4177 (1)	4185 (2)	Black	2.010"	3.010"	2.858"	1.000"	1.000"	1.275"	.409 lb
4379	15	4377 (1)	4385 (2)	Clear	3.012"	4.500"	3.813"	1.500"	1.500"	1.950"	1.214 lb
4379-Black	15	4377 (1)	4385 (2)	Black	3.012"	4.500"	3.813"	1.500"	1.500"	1.950"	1.214 lb
25-4178	25	25-4177 (1)	25-4185 (2)	Clear	50.24mm	75.00mm	72.78mm	25.00mm	25.00mm	31.88mm	.1756 kg
25-4178-Black	25	25-4177 (1)	25-4185 (2)	Black	50.24mm	75.00mm	72.78mm	25.00mm	25.00mm	31.88mm	.1756 kg
40-4379	40	40-4377 (1)	40-4385 (2)	Clear	80.33mm	120.00mm	114.68mm	40.00mm	40.00mm	51.43mm	.6123 kg
40-4379-Black	40	40-4377 (1)	40-4385 (2)	Black	80.33mm	120.00mm	114.68mm	40.00mm	40.00mm	51.43mm	.6123 kg

Material Specifications

Material	Alloy*	Finish
Aluminum	6105-T5	Anodize

* Or comparable

Included Mounting Hardware

Series	Nub to Profile		Arms to Nub		Arms to Profile	
	Part No.	Qty.	Part No.	Qty.	Part No.	Qty.
10	3306	2	3501	1	3356	2
15	3613	2	3500	1	3355	2
25	75-3415	2	25-3501	1	75-3509	2
40	75-3479	2	40-3500	1	75-3513	2

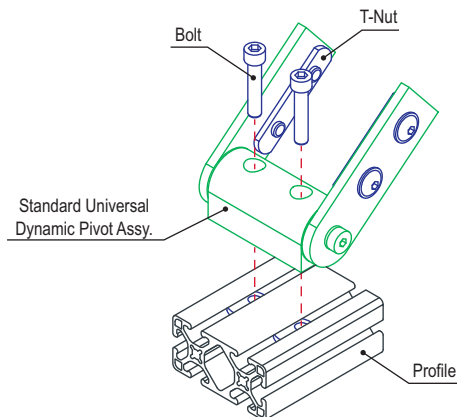

Standard 0 Degree Dynamic Pivot Assembly with Dual "L" Arms

Part Description:

The standard 0 degree dynamic pivot assembly with dual "L" arms is typically used to create dynamic pivots that are perpendicular to the mounting profile and have full axial motion ranging from 0-180 degrees. The assembly includes one 0 degree dynamic pivot nub and two "L" dynamic pivot arms. It has permanently lubricated bronze bushings that act as high-strength pivot points and nylon thrust washers that protect the pivot arms. This assembly offers a high load capacity while ensuring a long life cycle. The hardware to connect the nub to the profile, the nub to the arms, and the arms to the profile are all included.

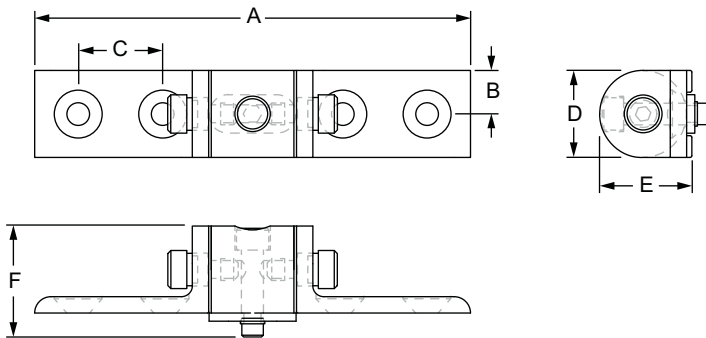

Part No.	Series	Nub (Qty.)	Arm (Qty.)	Color	A	B	C	D	E	F	Weight
4168	10	4181 (1)	4172 (2)	Clear	5.010"	.500"	1.000"	1.000"	1.060"	1.275"	.292 lb
4168-Black	10	4181 (1)	4172 (2)	Black	5.010"	.500"	1.000"	1.000"	1.060"	1.275"	.292 lb
4321	15	4381 (1)	4343 (2)	Clear	7.512"	.750"	1.500"	1.500"	1.600"	1.950"	.813 lb
4321-Black	15	4381 (1)	4343 (2)	Black	7.512"	.750"	1.500"	1.500"	1.600"	1.950"	.813 lb
25-4168	25	25-4181 (1)	25-4172 (2)	Clear	125.22mm	12.50mm	25.00mm	25.00mm	26.09mm	31.88mm	.1217 kg
25-4168-Black	25	25-4181 (1)	25-4172 (2)	Black	125.22mm	12.50mm	25.00mm	25.00mm	26.09mm	31.88mm	.1217 kg
40-4321	40	40-4381 (1)	40-4343 (2)	Clear	200.00mm	20.00mm	40.00mm	40.00mm	42.50mm	51.43mm	.4080 kg
40-4321-Black	40	40-4381 (1)	40-4343 (2)	Black	200.00mm	20.00mm	40.00mm	40.00mm	42.50mm	51.43mm	.4080 kg

Material Specifications

Material	Alloy*	Finish
Aluminum	6105-T5	Anodize

* Or comparable

Included Mounting Hardware

Series	Nub to Profile		Arms to Nub		Arms to Profile	
	Part No.	Qty.	Part No.	Qty.	Part No.	Qty.
10	3306	1	3501	1	3414	4
15	3613	1	3500	1	3412	4
25	75-3415	1	25-3501	1	75-3541	4
40	75-3479	1	40-3500	1	75-3508	4

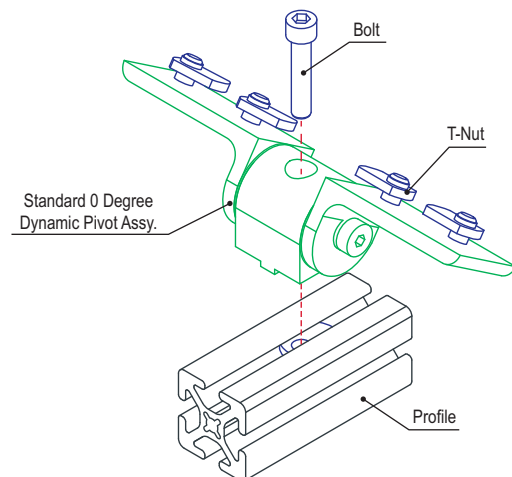

Standard 90 Degree Dynamic Pivot Assembly with Dual "L" Arms

Part Description:

The standard 90 degree dynamic pivot assembly with dual "L" arms is typically used to create dynamic pivots that are parallel to the mounting profile and have full axial motion ranging from 0-180 degrees. The assembly includes one 90 degree dynamic pivot nub and two "L" dynamic pivot arms. It has permanently lubricated bronze bushings that act as high-strength pivot points and nylon thrust washers that protect the pivot arms. This assembly offers a high load capacity while ensuring a long life cycle. The hardware to connect the nub to the profile, the nub to the arms, and the arms to the profile are all included.

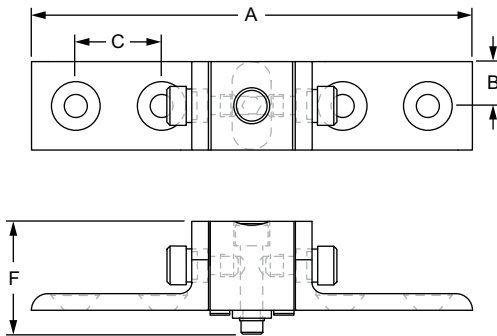

Part No.	Series	Nub (Qty.)	Arm (Qty.)	Color	A	B	C	D	E	F	Weight
4169	10	4184 (1)	4172 (2)	Clear	5.010"	.500"	1.000"	1.000"	1.000"	1.275"	.268 lb
4169-Black	10	4184 (1)	4172 (2)	Black	5.010"	.500"	1.000"	1.000"	1.000"	1.275"	.268 lb
4322	15	4384 (1)	4343 (2)	Clear	7.512"	.750"	1.500"	1.500"	1.500"	1.950"	.810 lb
4322-Black	15	4384 (1)	4343 (2)	Black	7.512"	.750"	1.500"	1.500"	1.500"	1.950"	.810 lb
25-4169	25	25-4184 (1)	25-4172 (2)	Clear	125.22mm	12.50mm	25.00mm	25.00mm	25.00mm	31.88mm	.1219 kg
25-4169-Black	25	25-4184 (1)	25-4172 (2)	Black	125.22mm	12.50mm	25.00mm	25.00mm	25.00mm	31.88mm	.1219 kg
40-4322	40	40-4384 (1)	40-4343 (2)	Clear	200.00mm	20.00mm	40.00mm	40.00mm	40.00mm	51.43mm	.4073 kg
40-4322-Black	40	40-4384 (1)	40-4343 (2)	Black	200.00mm	20.00mm	40.00mm	40.00mm	40.00mm	51.43mm	.4073 kg

Material Specifications

Material	Alloy*	Finish
Aluminum	6105-T5	Anodize

* Or comparable

Included Mounting Hardware

Series	Nub to Profile		Arms to Nub		Arms to Profile	
	Part No.	Qty.	Part No.	Qty.	Part No.	Qty.
10	3306	1	3501	1	3414	4
15	3613	1	3500	1	3412	4
25	75-3415	1	25-3501	1	75-3541	4
40	75-3479	1	40-3500	1	75-3508	4

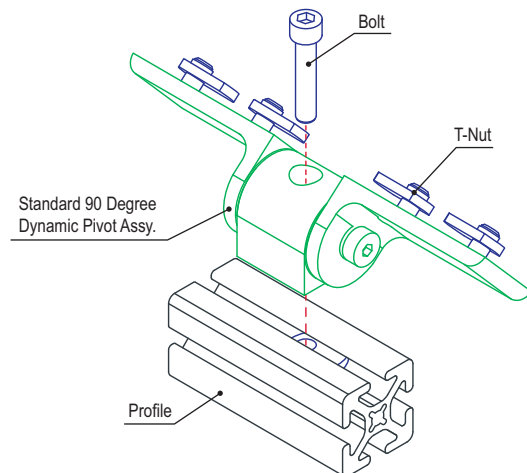

Standard Universal Dynamic Pivot Assembly with Dual "L" Arms

Part Description:

The standard universal dynamic pivot assembly with dual "L" arms is typically used to create either a perpendicular or parallel dynamic pivot with full axial motion ranging from 0-180 degrees. The assembly includes one universal dynamic pivot nub and two "L" dynamic pivot arms. It has permanently lubricated bronze bushings that act as high-strength pivot points and nylon thrust washers that protect the pivot arms. This assembly offers a high load capacity while ensuring a long life cycle. The hardware to connect the nub to the profile, the nub to the arms, and the arms to the profile are all included.

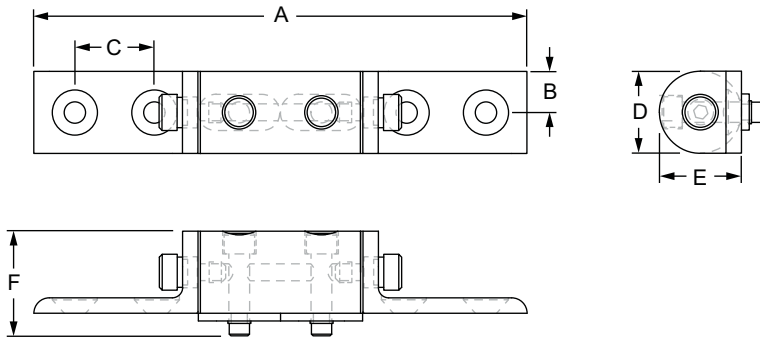

Part No.	Series	Nub (Qty.)	Arm (Qty.)	Color	A	B	C	D	E	F	Weight
4171	10	4177 (1)	4172 (2)	Clear	6.010"	.500"	1.000"	1.000"	1.000"	1.275"	.391 lb
4171-Black	10	4177 (1)	4172 (2)	Black	6.010"	.500"	1.000"	1.000"	1.000"	1.275"	.391 lb
4323	15	4377 (1)	4343 (2)	Clear	9.012"	.750"	1.500"	1.500"	1.500"	1.950"	1.275 lb
4323-Black	15	4377 (1)	4343 (2)	Black	9.012"	.750"	1.500"	1.500"	1.500"	1.950"	1.275 lb
25-4171	25	25-4177 (1)	25-4172 (2)	Clear	150.22mm	12.50mm	25.00mm	25.00mm	25.00mm	31.88mm	.1667 kg
25-4171-Black	25	25-4177 (1)	25-4172 (2)	Black	150.22mm	12.50mm	25.00mm	25.00mm	25.00mm	31.88mm	.1667 kg
40-4323	40	40-4377 (1)	40-4343 (2)	Clear	240.22mm	20.00mm	40.00mm	40.00mm	40.00mm	51.43mm	.5797 kg
40-4323-Black	40	40-4377 (1)	40-4343 (2)	Black	240.22mm	20.00mm	40.00mm	40.00mm	40.00mm	51.43mm	.5797 kg

Material Specifications

Material	Alloy*	Finish
Aluminum	6105-T5	Anodize

* Or comparable

Included Mounting Hardware

Series	Nub to Profile		Arms to Nub		Arms to Profile	
	Part No.	Qty.	Part No.	Qty.	Part No.	Qty.
10	3306	2	3501	1	3414	4
15	3613	2	3500	1	3412	4
25	75-3415	2	25-3501	1	75-3541	4
40	75-3479	2	40-3500	1	75-3508	4

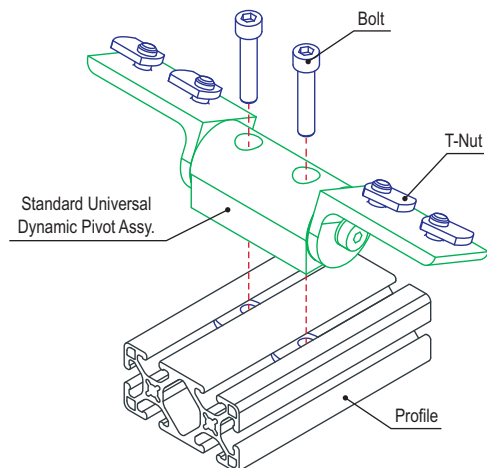

Standard 0 Degree Dynamic Pivot Assembly with Straight and "L" Arm

Part Description:

The standard 0 degree dynamic pivot assembly with straight and "L" arm is typically used to create dynamic pivots that are parallel to the mounting profile and have full axial motion ranging from 0-180 degrees. The assembly includes one 0 degree dynamic pivot nub, one standard straight dynamic pivot arm, and one "L" dynamic pivot arm. It has permanently lubricated bronze bushings that act as high-strength pivot points and nylon thrust washers that protect the pivot arms. This assembly offers a high load capacity while ensuring a long life cycle. The hardware to connect the nub to the profile, the nub to the arms, and the arms to the profile are all included.

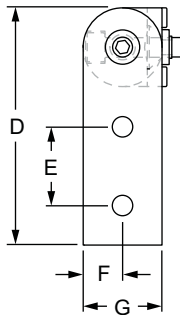
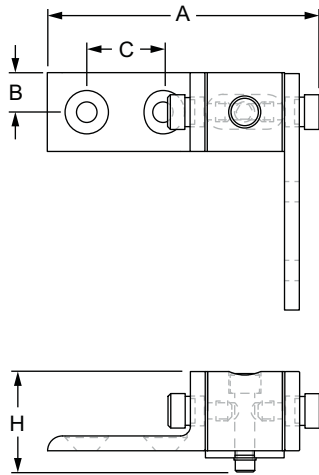

Part No.	Series	Nub (Qty.)	Arm (Qty.)	Color	A	B	C	D	E	F	G	H	Weight
4161	10	4181 (1)	4185 (1) 4172 (1)	Clear	3.448"	.500"	1.000"	3.010"	1.000"	.500"	1.000"	1.275"	.296 lb
4161-Black	10	4181 (1)	4185 (1) 4172 (1)	Black	3.448"	.500"	1.000"	3.010"	1.000"	.500"	1.000"	1.275"	.296 lb
4363	15	4381 (1)	4385 (1) 4343 (1)	Clear	5.074"	.750"	1.500"	4.500"	1.500"	.750"	1.500"	1.950"	.848 lb
4363-Black	15	4381 (1)	4385 (1) 4343 (1)	Black	5.074"	.750"	1.500"	4.500"	1.500"	.750"	1.500"	1.950"	.848 lb

Material Specifications

Material	Alloy*	Finish
Aluminum	6105-T5	Anodize

* Or comparable

Included Mounting Hardware

Series	Nub to Profile		Arms to Nub		Arms to Profile				
	Part No.	Qty.	Part No.	Qty.	Part No.	Qty.	AND	Part No.	Qty.
10	3306	1	3501	1	3356	1		3414	2
15	3613	1	3500	1	3355	1		3412	2

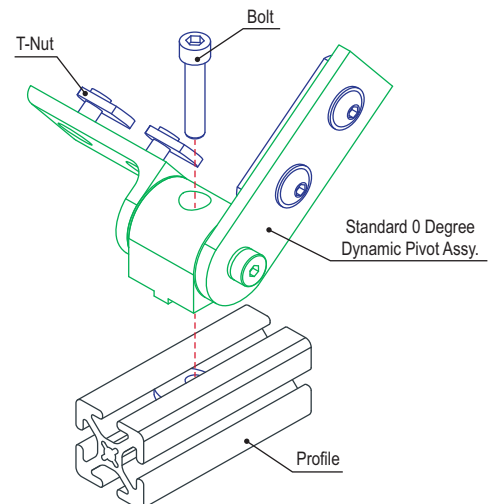

Standard 90 Degree Dynamic Pivot Assembly with Straight and "L" Arm

Part Description:

The standard 90 degree dynamic pivot assembly with straight and "L" arm is typically used to create dynamic pivots that are perpendicular to the mounting profile and have full axial motion ranging from 0-180 degrees. The assembly includes one 90 degree dynamic pivot nub, one standard straight dynamic pivot arm, and one "L" dynamic pivot arm. It has permanently lubricated bronze bushings that act as high-strength pivot points and nylon thrust washers that protect the pivot arms. This assembly offers a high load capacity while ensuring a long life cycle. The hardware to connect the nub to the profile, the nub to the arms, and the arms to the profile are all included.

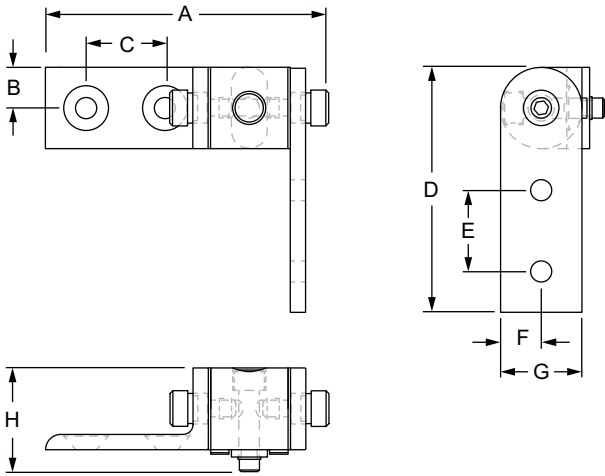

Part No.	Series	Nub (Qty.)	Arm (Qty.)	Color	A	B	C	D	E	F	G	H	Weight
4162	10	4184 (1)	4185 (1) 4172 (1)	Clear	3.448"	.500"	1.000"	3.010"	1.000"	.500"	1.000"	1.275"	.295 lb
4162-Black	10	4184 (1)	4185 (1) 4172 (1)	Black	3.448"	.500"	1.000"	3.010"	1.000"	.500"	1.000"	1.275"	.295 lb
4364	15	4384 (1)	4385 (1) 4343 (1)	Clear	5.074"	.750"	1.500"	4.500"	1.500"	.750"	1.500"	1.950"	.849 lb
4364-Black	15	4384 (1)	4385 (1) 4343 (1)	Black	5.074"	.750"	1.500"	4.500"	1.500"	.750"	1.500"	1.950"	.849 lb

Material Specifications

Material	Alloy*	Finish
Aluminum	6105-T5	Anodize

* Or comparable

Included Mounting Hardware

Series	Nub to Profile		Arms to Nub		Arms to Profile				
	Part No.	Qty.	Part No.	Qty.	Part No.	Qty.	AND	Part No.	Qty.
10	3306	1	3501	1	3356	1		3414	2
15	3613	1	3500	1	3355	1		3412	2

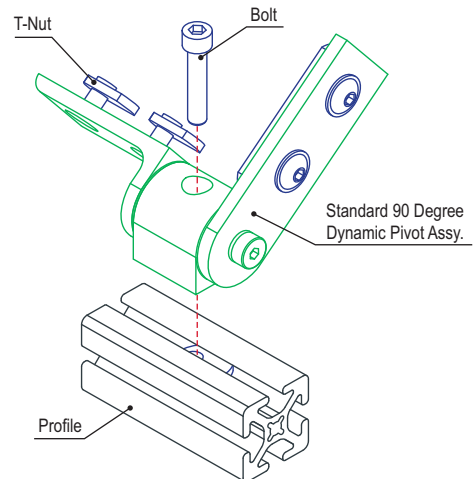

Standard Universal Dynamic Pivot Assembly with Straight and "L" Arm

Part Description:

The standard universal dynamic pivot assembly with straight and "L" arm is typically used to create either a perpendicular or parallel dynamic pivot with full axial motion ranging from 0-180 degrees. The assembly includes one universal dynamic pivot nub, one standard straight dynamic pivot arm, and one "L" dynamic pivot arm. It has permanently lubricated bronze bushings that act as high-strength pivot points and nylon thrust washers that protect the pivot arms. This assembly offers a high load capacity while ensuring a long life cycle. The hardware to connect the nub to the profile, the nub to the arms, and the arms to the profile are all included.

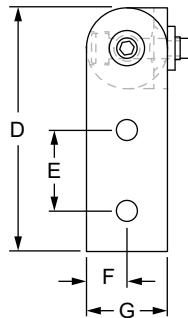
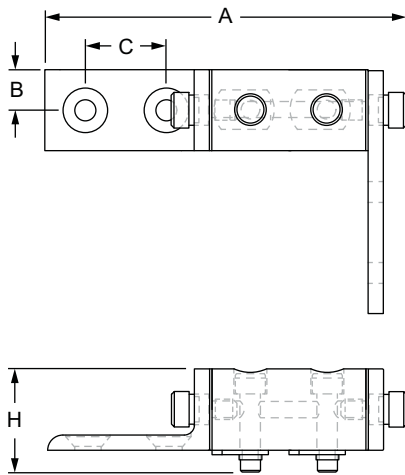

Part No.	Series	Nub (Qty.)	Arm (Qty.)	Color	A	B	C	D	E	F	G	H	Weight
4163	10	4177 (1)	4185 (1) 4172 (1)	Clear	4.448"	.500"	1.000"	3.010"	1.000"	.500"	1.000"	1.275"	.399 lb
4163-Black	10	4177 (1)	4185 (1) 4172 (1)	Black	4.448"	.500"	1.000"	3.010"	1.000"	.500"	1.000"	1.275"	.399 lb
4313	15	4377 (1)	4385 (1) 4343 (1)	Clear	6.574"	.750"	1.500"	4.500"	1.500"	.750"	1.500"	1.950"	1.178 lb
4313-Black	15	4377 (1)	4385 (1) 4343 (1)	Black	6.574"	.750"	1.500"	4.500"	1.500"	.750"	1.500"	1.950"	1.178 lb

Material Specifications

Material	Alloy*	Finish
Aluminum	6105-T5	Anodize

* Or comparable

Included Mounting Hardware

Series	Nub to Profile		Arms to Nub		Arms to Profile				
	Part No.	Qty.	Part No.	Qty.	Part No.	Qty.	AND	Part No.	Qty.
10	3306	2	3501	1	3356	1		3414	2
15	3613	2	3500	1	3355	1		3412	2

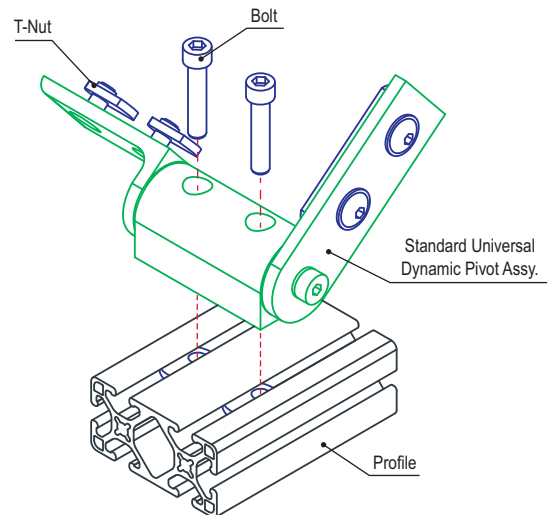

80/20®
Right Angle 0 Degree Dynamic Pivot Assembly with Dual Straight Arms

Part Description:

The right angle 0 degree dynamic pivot assembly with dual straight arms is typically used to create dynamic pivots that are parallel to the mounting profile and have full axial motion ranging from 0-90 degrees. The assembly includes one 0 degree dynamic right angle pivot nub and two standard straight dynamic pivot arms. It has permanently lubricated bronze bushings that act as high-strength pivot points and nylon thrust washers that protect the pivot arms. This assembly offers a high load capacity while ensuring a long life cycle. A shim kit and the hardware to connect the nub to the profile, the nub to the arms, and the arms to the profile are all included.

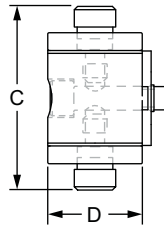
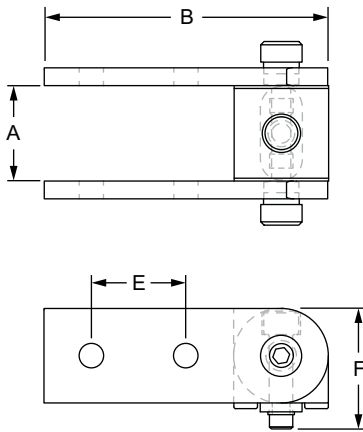

Part No.	Series	Nub (Qty.)	Arm (Qty.)	Color	A	B	C	D	E	F	Weight
4028	10	4025 (1)	4185 (2)	Clear	1.010"	3.010"	1.858"	1.000"	1.000"	1.275"	.312 lb
4028-Black	10	4025 (1)	4185 (2)	Black	1.010"	3.010"	1.858"	1.000"	1.000"	1.275"	.312 lb
4428	15	4425 (1)	4385 (2)	Clear	1.512"	4.500"	2.313"	1.500"	1.500"	1.950"	.903 lb
4428-Black	15	4425 (1)	4385 (2)	Black	1.512"	4.500"	2.313"	1.500"	1.500"	1.950"	.903 lb
25-4028	25	25-4025 (1)	25-4185 (2)	Clear	25.24mm	75.00mm	47.78mm	25.00mm	25.00mm	31.88mm	.1325 kg
25-4028-Black	25	25-4025 (1)	25-4185 (2)	Black	25.24mm	75.00mm	47.78mm	25.00mm	25.00mm	31.88mm	.1325 kg
40-4428	40	40-4425 (1)	40-4385 (2)	Clear	40.33mm	120.00mm	74.68mm	40.00mm	40.00mm	51.43mm	.4645 kg
40-4428-Black	40	40-4425 (1)	40-4385 (2)	Black	40.33mm	120.00mm	74.68mm	40.00mm	40.00mm	51.43mm	.4645 kg

Material Specifications

Material	Alloy*	Finish
Aluminum	6105-T5	Anodize

* Or comparable

Included Mounting Hardware

Series	Nub to Profile		Arms to Nub		Arms to Profile	
	Part No.	Qty.	Part No.	Qty.	Part No.	Qty.
10	3306	1	3501	1	3356	2
15	3613	1	3500	1	3355	2
25	75-3415	1	25-3501	1	75-3509	2
40	75-3479	1	40-3500	1	75-3513	2

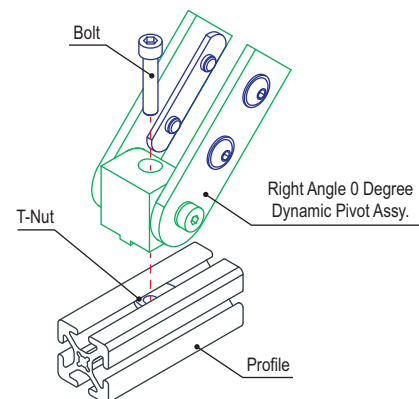

Right Angle 90 Degree Dynamic Pivot Assembly with Dual Straight Arms

Part Description:

The right angle 90 degree dynamic pivot assembly with dual straight arms is typically used to create dynamic pivots that are perpendicular to the mounting profile and have full axial motion ranging from 0-90 degrees. The assembly includes one 90 degree dynamic right angle pivot nub and two standard straight dynamic pivot arms. It has permanently lubricated bronze bushings that act as high-strength pivot points and nylon thrust washers that protect the arms. This assembly offers a high load capacity while ensuring a long life cycle. A shim kit and the hardware to connect the nub to the profile, the nub to the arms, and the arms to the profile are all included.

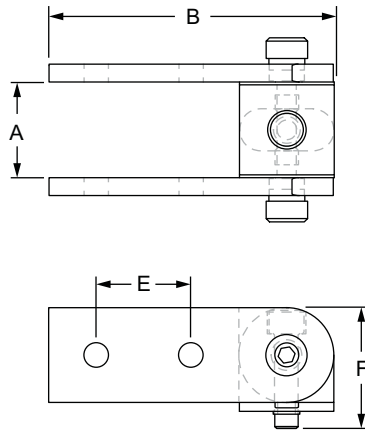

Part No.	Series	Nub (Qty.)	Arm (Qty.)	Color	A	B	C	D	E	F	Weight
4029	10	4026 (1)	4185 (2)	Clear	1.010"	3.010"	1.858"	1.000"	1.000"	1.275"	.311 lb
4029-Black	10	4026 (1)	4185 (2)	Black	1.010"	3.010"	1.858"	1.000"	1.000"	1.275"	.311 lb
4429	15	4426 (1)	4385 (2)	Clear	1.512"	4.500"	2.313"	1.500"	1.500"	1.950"	.903 lb
4429-Black	15	4426 (1)	4385 (2)	Black	1.512"	4.500"	2.313"	1.500"	1.500"	1.950"	.903 lb
25-4029	25	25-4026 (1)	25-4185 (2)	Clear	25.24mm	75.00mm	47.78mm	25.00mm	25.00mm	31.88mm	.1324 kg
25-4029-Black	25	25-4026 (1)	25-4185 (2)	Black	25.24mm	75.00mm	47.78mm	25.00mm	25.00mm	31.88mm	.1324 kg
40-4429	40	40-4426 (1)	40-4385 (2)	Clear	40.33mm	120.00mm	74.68mm	40.00mm	40.00mm	51.43mm	.4573 kg
40-4429-Black	40	40-4426 (1)	40-4385 (2)	Black	40.33mm	120.00mm	74.68mm	40.00mm	40.00mm	51.43mm	.4573 kg

Material Specifications

Material	Alloy*	Finish
Aluminum	6105-T5	Anodize

* Or comparable

Included Mounting Hardware

Series	Nub to Profile		Arms to Nub		Arms to Profile	
	Part No.	Qty.	Part No.	Qty.	Part No.	Qty.
10	3306	1	3501	1	3356	2
15	3613	1	3500	1	3355	2
25	75-3415	1	25-3501	1	75-3509	2
40	75-3479	1	40-3500	1	75-3513	2

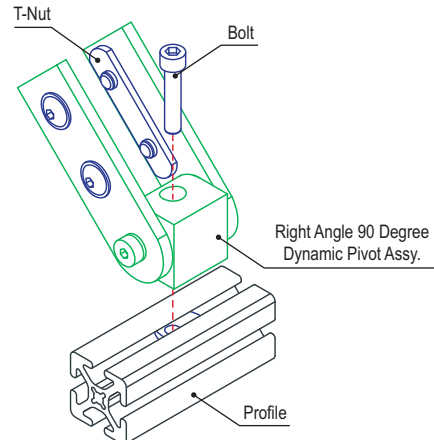

80/20®
Right Angle Universal Dynamic Pivot Assembly with Dual Straight Arms

Part Description:

The right angle universal dynamic pivot assembly with dual straight arms is typically used to create either a perpendicular or parallel dynamic pivot with full axial motion ranging from 0-90 degrees. The assembly includes one universal dynamic right angle pivot nub and two standard straight dynamic pivot arms. It has permanently lubricated bronze bushings that act as high-strength pivot points and nylon thrust washers that protect the pivot arms. This assembly offers a high load capacity while ensuring a long life cycle. A shim kit and the hardware to connect the nub to the profile, the nub to the arms, and the arms to the profile are all included.

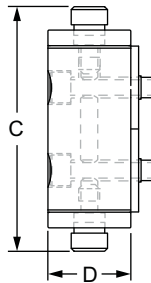
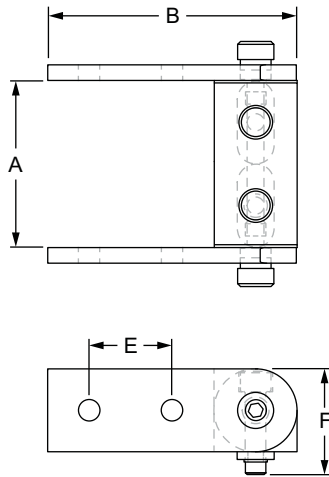

Part No.	Series	Nub (Qty.)	Arm (Qty.)	Color	A	B	C	D	E	F	Weight
4030	10	4027 (1)	4185 (2)	Clear	2.010"	3.010"	2.858"	1.000"	1.000"	1.275"	.417 lb
4030-Black	10	4027 (1)	4185 (2)	Black	2.010"	3.010"	2.858"	1.000"	1.000"	1.275"	.417 lb
4430	15	4427 (1)	4385 (2)	Clear	3.012"	4.500"	3.813"	1.500"	1.500"	1.950"	1.252 lb
4430-Black	15	4427 (1)	4385 (2)	Black	3.012"	4.500"	3.813"	1.500"	1.500"	1.950"	1.252 lb
25-4030	25	25-4027 (1)	25-4185 (2)	Clear	50.24mm	75.00mm	72.78mm	25.00mm	25.00mm	31.88mm	.1793 kg
25-4030-Black	25	25-4027 (1)	25-4185 (2)	Black	50.24mm	75.00mm	72.78mm	25.00mm	25.00mm	31.88mm	.1793 kg
40-4430	40	40-4427 (1)	40-4385 (2)	Clear	80.33mm	120.00mm	114.68mm	40.00mm	40.00mm	51.43mm	.6331 kg
40-4430-Black	40	40-4427 (1)	40-4385 (2)	Black	80.33mm	120.00mm	114.68mm	40.00mm	40.00mm	51.43mm	.6331 kg

Material Specifications

Material	Alloy*	Finish
Aluminum	6105-T5	Anodize

* Or comparable

Included Mounting Hardware

Series	Nub to Profile		Arms to Nub		Arms to Profile	
	Part No.	Qty.	Part No.	Qty.	Part No.	Qty.
10	3306	2	3501	1	3356	2
15	3613	2	3500	1	3355	2
25	75-3415	2	25-3501	1	75-3509	2
40	75-3479	2	40-3500	1	75-3513	2

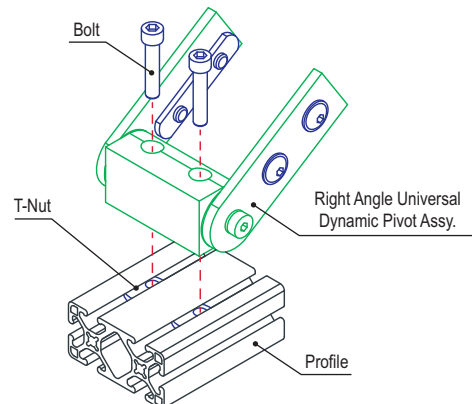

Right Angle 0 Degree Dynamic Pivot Assembly with Dual "L" Arms

Part Description:

The right angle 0 degree dynamic pivot assembly with dual "L" arms is typically used to create dynamic pivots that are perpendicular to the mounting profile and have full axial motion ranging from 0-90 degrees. The assembly includes one 0 degree dynamic right angle pivot nub and two "L" dynamic pivot arms. It has permanently lubricated bronze bushings that act as high-strength pivot points and nylon thrust washers that protect the pivot arms. This assembly offers a high load capacity while ensuring a long life cycle. The hardware to connect the nub to the profile, the nub to the arms, and the arms to the profile are all included.

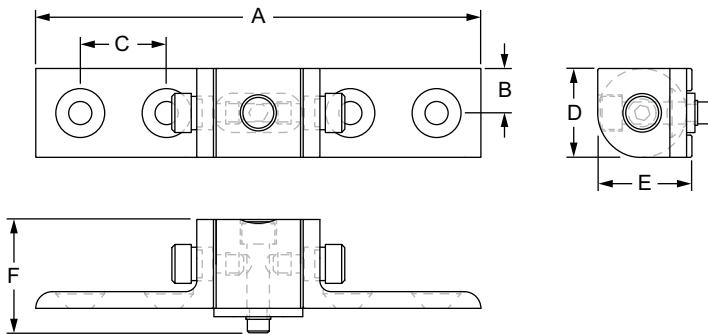

Part No.	Series	Nub (Qty.)	Arm (Qty.)	Color	A	B	C	D	E	F	Weight
4031	10	4025 (1)	4172 (2)	Clear	5.010"	.500"	1.000"	1.000"	1.060"	1.275"	.291 lb
4031-Black	10	4025 (1)	4172 (2)	Black	5.010"	.500"	1.000"	1.000"	1.060"	1.275"	.291 lb
4431	15	4425 (1)	4343 (2)	Clear	7.512"	.750"	1.500"	1.500"	1.600"	1.950"	.828 lb
4431-Black	15	4425 (1)	4343 (2)	Black	7.512"	.750"	1.500"	1.500"	1.600"	1.950"	.828 lb
25-4031	25	25-4025 (1)	25-4172 (2)	Clear	125.22mm	12.50mm	25.00mm	25.00mm	26.09mm	31.88mm	.1240 kg
25-4031-Black	25	25-4025 (1)	25-4172 (2)	Black	125.22mm	12.50mm	25.00mm	25.00mm	26.09mm	31.88mm	.1240 kg
40-4431	40	40-4425 (1)	40-4343 (2)	Clear	200.22mm	20.00mm	40.00mm	40.00mm	42.50mm	51.43mm	.4157 kg
40-4431-Black	40	40-4425 (1)	40-4343 (2)	Black	200.22mm	20.00mm	40.00mm	40.00mm	42.50mm	51.43mm	.4157 kg

Material Specifications

Material	Alloy*	Finish
Aluminum	6105-T5	Anodize

* Or comparable

Included Mounting Hardware

Series	Nub to Profile		Arms to Nub		Arms to Profile	
	Part No.	Qty.	Part No.	Qty.	Part No.	Qty.
10	3306	1	3501	1	3414	4
15	3613	1	3500	1	3412	4
25	75-3415	1	25-3501	1	75-3541	4
40	75-3479	1	40-3500	1	75-3508	4

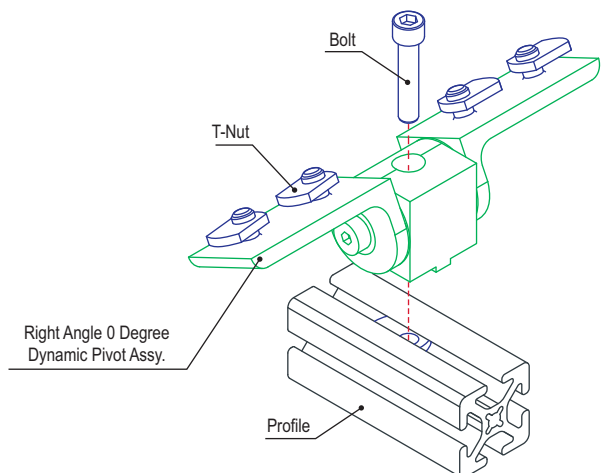

80/20® Right Angle 90 Degree Dynamic Pivot Assembly with Dual "L" Arms

Part Description:

The right angle 90 degree dynamic pivot assembly with dual "L" arms is typically used to create dynamic pivots that are parallel to the mounting profile and have full axial motion ranging from 0-90 degrees. The assembly includes one 90 degree dynamic right angle pivot nub and two "L" dynamic pivot arms. It has permanently lubricated bronze bushings that act as high-strength pivot points and nylon thrust washers that protect the pivot arms. This assembly offers a high load capacity while ensuring a long life cycle. The hardware to connect the nub to the profile, the nub to the arms, and the arms to the profile are all included.

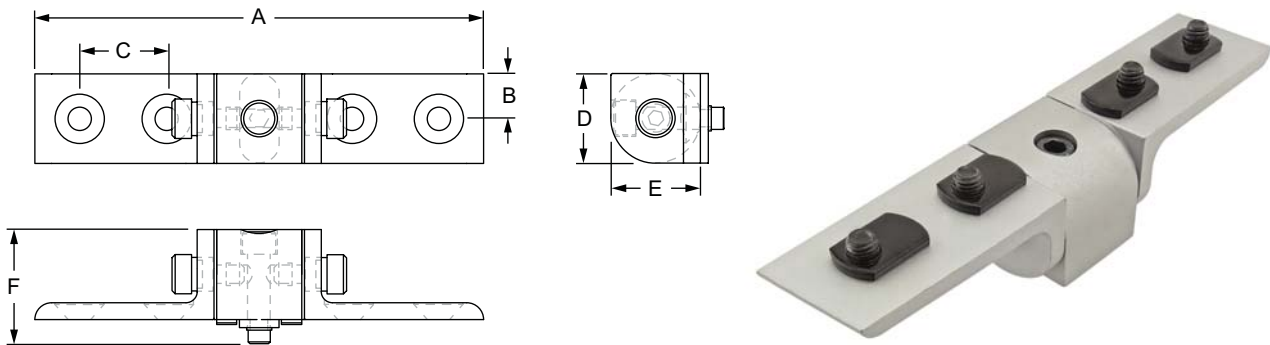

Part No.	Series	Nub (Qty.)	Arm (Qty.)	Color	A	B	C	D	E	F	Weight
4032	10	4026 (1)	4172 (2)	Clear	5.010"	.500"	1.000"	1.000"	1.000"	1.275"	.291 lb
4032-Black	10	4026 (1)	4172 (2)	Black	5.010"	.500"	1.000"	1.000"	1.000"	1.275"	.291 lb
4432	15	4426 (1)	4343 (2)	Clear	7.512"	.750"	1.500"	1.500"	1.500"	1.950"	.827 lb
4432-Black	15	4426 (1)	4343 (2)	Black	7.512"	.750"	1.500"	1.500"	1.500"	1.950"	.827 lb
25-4032	25	25-4026 (1)	25-4172 (2)	Clear	125.22mm	12.50mm	25.00mm	25.00mm	25.00mm	31.88mm	.1236 kg
25-4032-Black	25	25-4026 (1)	25-4172 (2)	Black	125.22mm	12.50mm	25.00mm	25.00mm	25.00mm	31.88mm	.1236 kg
40-4432	40	40-4426 (1)	40-4343 (2)	Clear	200.22mm	20.00mm	40.00mm	40.00mm	40.00mm	51.43mm	.4164 kg
40-4432-Black	40	40-4426 (1)	40-4343 (2)	Black	200.22mm	20.00mm	40.00mm	40.00mm	40.00mm	51.43mm	.4164 kg

Material Specifications

Material	Alloy*	Finish
Aluminum	6105-T5	Anodize

* Or comparable

Included Mounting Hardware

Series	Nub to Profile		Arms to Nub		Arms to Profile	
	Part No.	Qty.	Part No.	Qty.	Part No.	Qty.
10	3306	1	3501	1	3414	4
15	3613	1	3500	1	3412	4
25	75-3415	1	25-3501	1	75-3541	4
40	75-3479	1	40-3500	1	75-3508	4

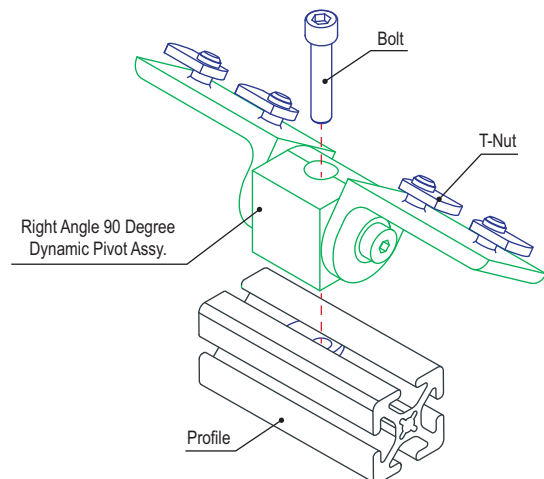

Right Angle Universal Dynamic Pivot Assembly with Dual "L" Arms

Part Description:

The right angle universal dynamic pivot assembly with dual "L" arms is typically used to create either a perpendicular or parallel dynamic pivot with full axial motion ranging from 0-90 degrees. The assembly includes one universal dynamic right angle pivot nub and two "L" dynamic pivot arms. It has permanently lubricated bronze bushings that act as high-strength pivot points and nylon thrust washers that protect the pivot arms. This assembly offers a high load capacity while ensuring a long life cycle. The hardware to connect the nub to the profile, the nub to the arms, and the arms to the profile are all included.

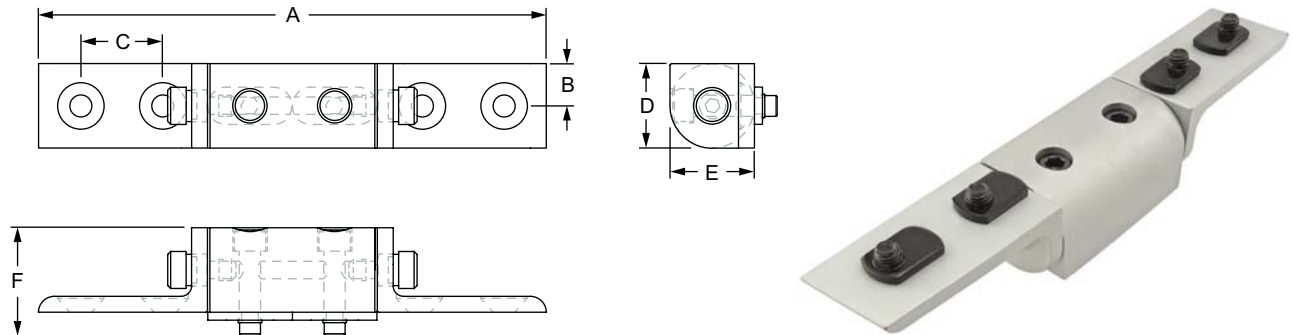

Part No.	Series	Nub (Qty.)	Arm (Qty.)	Color	A	B	C	D	E	F	Weight
4033	10	4027 (1)	4172 (2)	Clear	6.010"	.500"	1.000"	1.000"	1.000"	1.275"	.398 lb
4033-Black	10	4027 (1)	4172 (2)	Black	6.010"	.500"	1.000"	1.000"	1.000"	1.275"	.398 lb
4433	15	4427 (1)	4343 (2)	Clear	9.012"	.750"	1.500"	1.500"	1.500"	1.950"	1.201 lb
4433-Black	15	4427 (1)	4343 (2)	Black	9.012"	.750"	1.500"	1.500"	1.500"	1.950"	1.201 lb
25-4033	25	25-4027 (1)	25-4172 (2)	Clear	150.22mm	12.50mm	25.00mm	25.00mm	25.00mm	31.88mm	.1705 kg
25-4033-Black	25	25-4027 (1)	25-4172 (2)	Black	150.22mm	12.50mm	25.00mm	25.00mm	25.00mm	31.88mm	.1705 kg
40-4433	40	40-4427 (1)	40-4343 (2)	Clear	240.22mm	20.00mm	40.00mm	40.00mm	40.00mm	51.43mm	.5925 kg
40-4433-Black	40	40-4427 (1)	40-4343 (2)	Black	240.22mm	20.00mm	40.00mm	40.00mm	40.00mm	51.43mm	.5925 kg

Material Specifications

Material	Alloy*	Finish
Aluminum	6105-T5	Anodize

* Or comparable

Included Mounting Hardware

Series	Nub to Profile		Arms to Nub		Arms to Profile	
	Part No.	Qty.	Part No.	Qty.	Part No.	Qty.
10	3306	2	3501	1	3414	4
15	3613	2	3500	1	3412	4
25	75-3415	2	25-3501	1	75-3541	4
40	75-3479	2	40-3500	1	75-3508	4

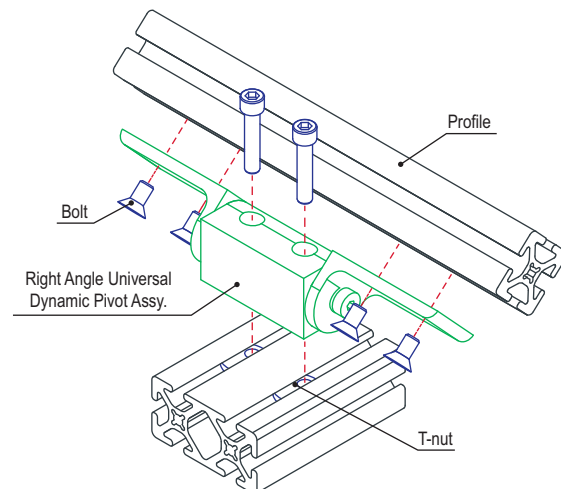



Part Description:

The 90 degree left hand pivot bracket plate is commonly used to add motion to certain elements of your project. The plate provides a full 90 degrees of axial motion and has a permanently lubricated bronze bushing that acts as high-strength pivot point. See below for the suggested hardware to mount the plate to a profile.

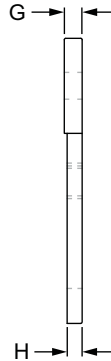
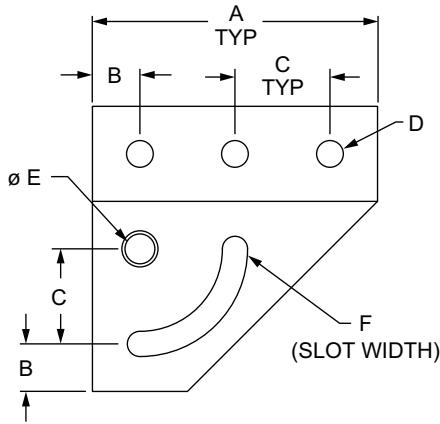

Part No.	Series	Color	A	B	C	D	E	F	G	H	Weight
4133	10	Clear	3.000"	.500"	1.000"	.281"	.312"	.265"	.188"	.158"	.100 lb
4133-Black	10	Black	3.000"	.500"	1.000"	.281"	.312"	.265"	.188"	.158"	.100 lb
4333	15	Clear	4.500"	.750"	1.500"	.328"	.375"	.328"	.250"	.220"	.335 lb
4333-Black	15	Black	4.500"	.750"	1.500"	.328"	.375"	.328"	.250"	.220"	.335 lb
25-4133	25	Clear	75.00mm	12.50mm	25.00mm	6.50mm	8.00mm	6.73mm	4.00mm	3.24mm	.0376 kg
25-4133-Black	25	Black	75.00mm	12.50mm	25.00mm	6.50mm	8.00mm	6.73mm	4.00mm	3.24mm	.0376kg
40-4333	40	Clear	120.00mm	20.00mm	40.00mm	8.33mm	10.00mm	8.33mm	6.00mm	5.19mm	.1550 kg
40-4333-Black	40	Black	120.00mm	20.00mm	40.00mm	8.33mm	10.00mm	8.33mm	6.00mm	5.19mm	.1550 kg

Material Specifications

Material	Alloy*	Finish
Aluminum	6105-T5	Anodize

* Or comparable

Suggested Hardware (Mount to T-Slot)

Part No.	Series	Qty.	Bolt	T-Nut
3321	10	3	1/4-20 x 1/2" FBHSCS	Economy
3320	15	3	5/16-18 x 5/8" FBHSCS	
75-3404	25	3	M6 x 10mm BHSCS	
75-3422	40	3	M8 x 16mm BHSCS	

90 Degree Right Hand Pivot Bracket Plate

Part Description:

The 90 degree right hand pivot bracket plate is commonly used to add motion to certain elements of your project. The plate provides a full 90 degrees of axial motion and has a permanently lubricated bronze bushing that acts as high-strength pivot point. See below for the suggested hardware to mount the plate to a profile.

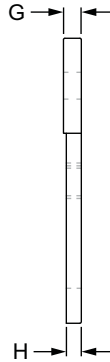
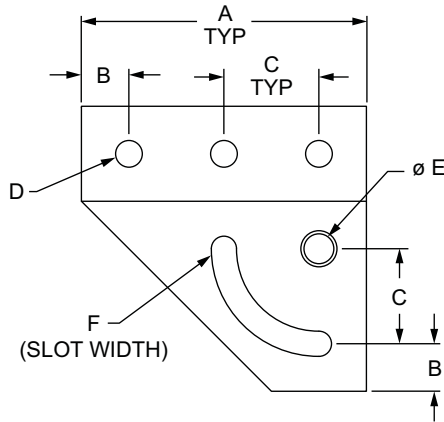

Part No.	Series	Color	A	B	C	D	E	F	G	H	Weight
4137	10	Clear	3.000"	.500"	1.000"	.281"	.312"	.265"	.188"	.158"	.102 lb
4137-Black	10	Black	3.000"	.500"	1.000"	.281"	.312"	.265"	.188"	.158"	.102 lb
4337	15	Clear	4.500"	.750"	1.500"	.328"	.375"	.328"	.250"	.220"	.334 lb
4337-Black	15	Black	4.500"	.750"	1.500"	.328"	.375"	.328"	.250"	.220"	.334 lb
25-4137	25	Clear	75.00mm	12.50mm	25.00mm	6.50mm	8.00mm	6.73mm	4.00mm	3.24mm	.0376 kg
25-4137-Black	25	Black	75.00mm	12.50mm	25.00mm	6.50mm	8.00mm	6.73mm	4.00mm	3.24mm	.0376 kg
40-4337	40	Clear	120.00mm	20.00mm	40.00mm	8.33mm	10.00mm	8.33mm	6.00mm	5.19mm	.1532 kg
40-4337-Black	40	Black	120.00mm	20.00mm	40.00mm	8.33mm	10.00mm	8.33mm	6.00mm	5.19mm	.1532 kg

Material Specifications

Material	Alloy*	Finish
Aluminum	6105-T5	Anodize

* Or comparable

Suggested Hardware (Mount to T-Slot)

Part No.	Series	Qty.	Bolt	T-Nut
3321	10	3	1/4-20 x 1/2" FBHSCS	Economy
3320	15	3	5/16-18 x 5/8" FBHSCS	
75-3404	25	3	M6 x 10mm BHSCS	
75-3422	40	3	M8 x 16mm BHSCS	



80/20® 90 Degree Left Hand Pivot Bracket Assembly with "L" Handle

Part Description:

The 90 degree left hand pivot bracket assembly with "L" handle is commonly used to add motion to certain elements of your project. It is comprised of one 90 degree left hand pivot bracket, one "L" handle, and one 0 degree structural pivot nub. The shoulder bolt and nylon thrust washers are also included. The bracket has a permanently lubricated bronze bushing that acts as high-strength pivot point. It offers a high load capacity while ensuring a long life cycle.

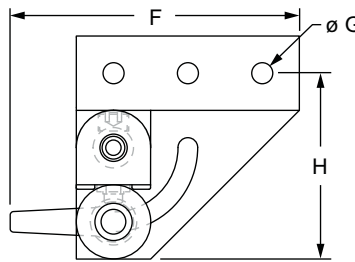
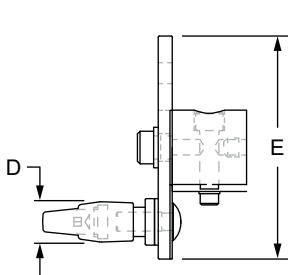
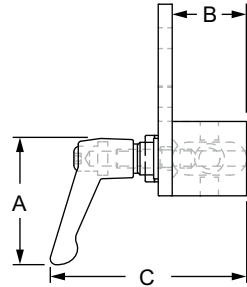

Part No.	Series	Plate (Qty.)	Nub (Qty.)	Handle (Qty.)	Color	A	B	C	D	E	F	G	H	Weight
4139	10	4133 (1)	4187 (1)	2796 (1)	Clear	2.041"	1.000"	2.754"	.541"	3.000"	4.270"	.281"	2.500"	.274 lb
4139-Black	10	4133 (1)	4187 (1)	2796 (1)	Black	2.041"	1.000"	2.754"	.541"	3.000"	4.270"	.281"	2.500"	.274 lb
4339	15	4333 (1)	4387 (1)	2797 (1)	Clear	3.505"	1.500"	4.015"	.871"	4.500"	6.820"	.328"	3.750"	1.029 lb
4339-Black	15	4333 (1)	4387 (1)	2797 (1)	Black	3.505"	1.500"	4.015"	.871"	4.500"	6.820"	.328"	3.750"	1.029 lb
25-4139	25	25-4133 (1)	25-4187 (1)	25-2796 (1)	Clear	51.84mm	25.00mm	69.24mm	13.77mm	75.00mm	107.46mm	6.50mm	62.50mm	.1144 kg
25-4139-Black	25	25-4133 (1)	25-4187 (1)	25-2796 (1)	Black	51.84mm	25.00mm	69.24mm	13.77mm	75.00mm	107.46mm	6.50mm	62.50mm	.1144 kg
40-4339	40	40-4333 (1)	40-4387 (1)	40-2797 (1)	Clear	89.03mm	40.00mm	103.53mm	22.12mm	120.00mm	177.98mm	8.48mm	100.00mm	.4944 kg
40-4339-Black	40	40-4333 (1)	40-4387 (1)	40-2797 (1)	Black	89.03mm	40.00mm	103.53mm	22.12mm	120.00mm	177.98mm	8.48mm	100.00mm	.4944 kg

Material Specifications

Material	Alloy*	Finish
Aluminum	6105-T5	Anodize

* Or comparable

Suggested Hardware (Mount to T-Slot)

Part No.	Series	Qty.	Bolt	T-Nut
3321	10	3	1/4-20 x 1/2" FBHSCS	Economy
3320	15	3	5/16-18 x 5/8" FBHSCS	
75-3404	25	3	M6 x 10mm BHSCS	
75-3422	40	3	M8 x 16mm BHSCS	

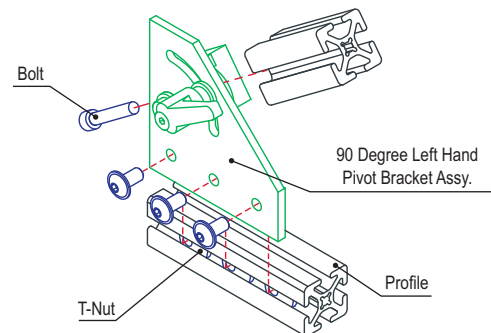

90 Degree Left Hand Pivot Bracket Assembly with "T" Handle

Part Description:

The 90 degree left hand pivot bracket assembly with "T" handle is commonly used to add motion to certain elements of your project. It is comprised of one 90 degree left hand pivot bracket, one "T" handle, and one 0 degree structural pivot nub. The shoulder bolt and nylon thrust washers are also included. The bracket has a permanently lubricated bronze bushing that acts as high-strength pivot point. It offers a high load capacity while ensuring a long life cycle.

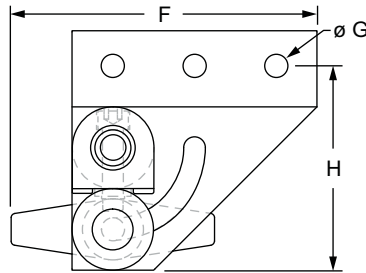
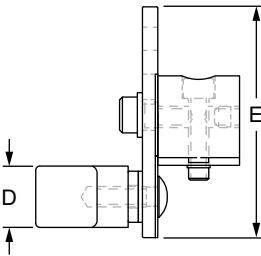
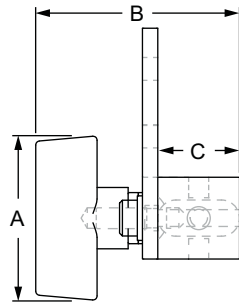

Part No.	Series	Plate (Qty.)	Nub (Qty.)	Handle (Qty.)	Color	A	B	C	D	E	F	G	H	Weight
4142	10	4133 (1)	4187 (1)	2798 (1)	Clear	2.490"	2.493"	1.000"	.750"	3.000"	3.745"	.281"	2.500"	.281 lb
4142-Black	10	4133 (1)	4187 (1)	2798 (1)	Black	2.490"	2.493"	1.000"	.750"	3.000"	3.745"	.281"	2.500"	.281 lb
4342	15	4333 (1)	4387 (1)	2799 (1)	Clear	2.490"	2.977"	1.500"	.750"	4.500"	5.245"	.328"	3.750"	.784 lb
4342-Black	15	4333 (1)	4387 (1)	2799 (1)	Black	2.490"	2.977"	1.500"	.750"	4.500"	5.245"	.328"	3.750"	.784 lb

Material Specifications

Material	Alloy*	Finish
Aluminum	6105-T5	Anodize

* Or comparable

Suggested Hardware (Mount to T-Slot)

Part No.	Series	Qty.	Bolt	T-Nut
3321	10	3	1/4-20 x 1/2" FBHSCS	Economy
3320	15	3	5/16-18 x 5/8" FBHSCS	

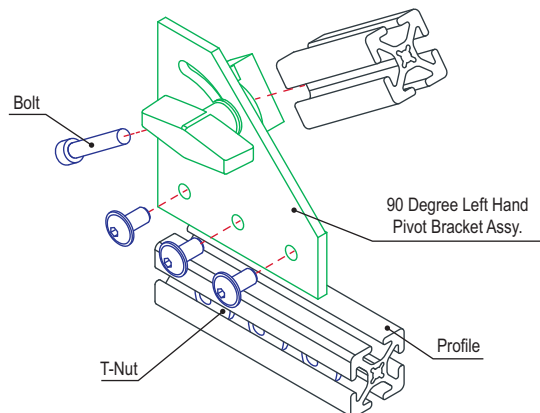



90 Degree Right Hand Pivot Bracket Assembly with "L" Handle

Part Description:

The 90 degree right hand pivot bracket assembly with "L" handle is commonly used to add motion to certain elements of your project. It is comprised of one 90 degree right hand pivot bracket, one "L" handle, and one 0 degree structural pivot nub. The shoulder bolt and nylon thrust washers are also included. The bracket has a permanently lubricated bronze bushing that acts as high-strength pivot point. It offers a high load capacity while ensuring a long life cycle.

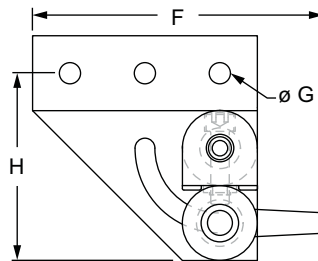
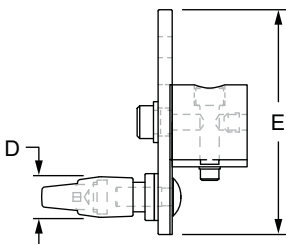
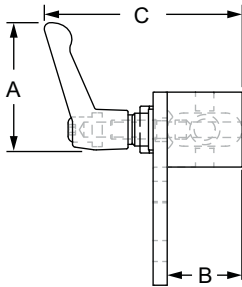

Part No.	Series	Plate (Qty.)	Nub (Qty.)	Handle (Qty.)	Color	A	B	C	D	E	F	G	H	Weight
4148	10	4137 (1)	4187 (1)	2796 (1)	Clear	2.041"	1.000"	2.754"	.541"	3.000"	4.270"	.281"	2.500"	.277 lb
4148-Black	10	4137 (1)	4187 (1)	2796 (1)	Black	2.041"	1.000"	2.754"	.541"	3.000"	4.270"	.281"	2.500"	.277 lb
4348	15	4337 (1)	4387 (1)	2797 (1)	Clear	3.505"	1.500"	4.015"	.871"	4.500"	6.820"	.328"	3.750"	1.018 lb
4348-Black	15	4337 (1)	4387 (1)	2797 (1)	Black	3.505"	1.500"	4.015"	.871"	4.500"	6.820"	.328"	3.750"	1.018 lb
25-4148	25	25-4137 (1)	25-4187 (1)	25-2796 (1)	Clear	51.84mm	25.00mm	69.24mm	13.77mm	75.00mm	107.46mm	6.50mm	62.50mm	.1146 kg
25-4148-Black	25	25-4137 (1)	25-4187 (1)	25-2796 (1)	Black	51.84mm	25.00mm	69.24mm	13.77mm	75.00mm	107.46mm	6.50mm	62.50mm	.1146 kg
40-4348	40	40-4337 (1)	40-4387 (1)	40-2797 (1)	Clear	89.03mm	40.00mm	103.53mm	22.12mm	120.00mm	177.98mm	8.48mm	100.00mm	.4927 kg
40-4348-Black	40	40-4337 (1)	40-4387 (1)	40-2797 (1)	Black	89.03mm	40.00mm	103.53mm	22.12mm	120.00mm	177.98mm	8.48mm	100.00mm	.4927 kg

Material Specifications

Material	Alloy*	Finish
Aluminum	6105-T5	Anodize

* Or comparable

Suggested Hardware (Mount to T-Slot)

Part No.	Series	Qty.	Bolt	T-Nut
3321	10	3	1/4-20 x 1/2" FBHSCS	Economy
3320	15	3	5/16-18 x 5/8" FBHSCS	
75-3404	25	3	M6 x 10mm BHSCS	
75-3422	40	3	M8 x 16mm BHSCS	

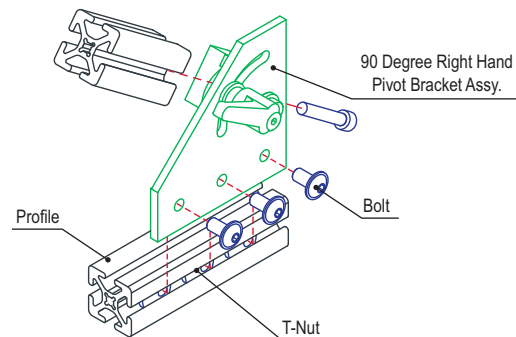

90 Degree Right Hand Pivot Bracket Assembly with "T" Handle

Part Description:

The 90 degree right hand pivot bracket assembly with "T" handle is commonly used to add motion to certain elements of your project. It is comprised of one 90 degree right hand pivot bracket, one "T" handle, and one 0 degree structural pivot nub. The shoulder bolt and nylon thrust washers are also included. The bracket has a permanently lubricated bronze bushing that acts as high-strength pivot point. It offers a high load capacity while ensuring a long life cycle.

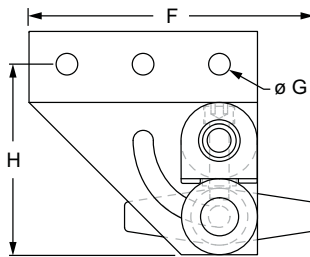
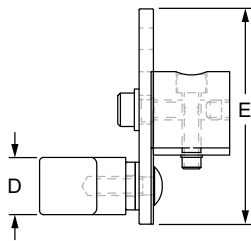
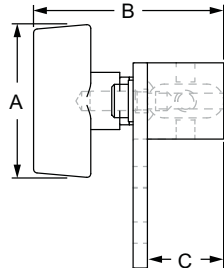

Part No.	Series	Plate (Qty.)	Nub (Qty.)	Handle (Qty.)	Color	A	B	C	D	E	F	G	H	Weight
4147	10	4137 (1)	4187 (1)	2798 (1)	Clear	2.490"	2.493"	1.000"	.750"	3.000"	3.745"	.281"	2.500"	.287 lb
4147-Black	10	4137 (1)	4187 (1)	2798 (1)	Black	2.490"	2.493"	1.000"	.750"	3.000"	3.745"	.281"	2.500"	.287 lb
4347	15	4337 (1)	4387 (1)	2799 (1)	Clear	2.490"	2.977"	1.500"	.750"	4.500"	5.245"	.328"	3.750"	.774 lb
4347-Black	15	4337 (1)	4387 (1)	2799 (1)	Black	2.490"	2.977"	1.500"	.750"	4.500"	5.245"	.328"	3.750"	.774 lb

Material Specifications

Material	Alloy*	Finish
Aluminum	6105-T5	Anodize

* Or comparable

Suggested Hardware (Mount to T-Slot)

Part No.	Series	Qty.	Bolt	T-Nut
3321	10	3	1/4-20 x 1/2" FBHSCS	Economy
3320	15	3	5/16-18 x 5/8" FBHSCS	

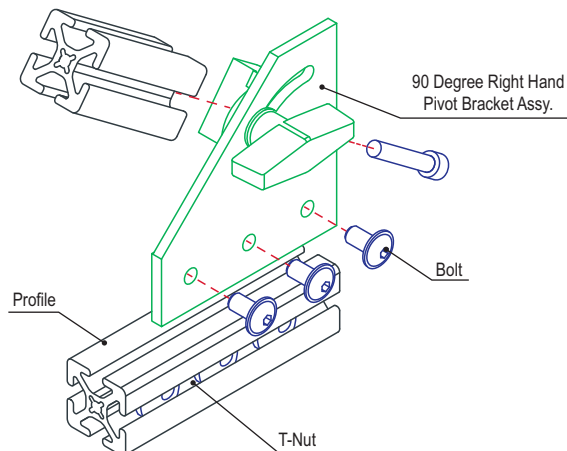



80/20® 90 Degree Double Pivot Bracket Assembly with "L" Handles

Part Description:

The 90 degree double pivot bracket assembly with "L" handles is commonly used to add motion to certain elements of your project. It is comprised of one 90 degree left hand pivot bracket, one 90 degree right hand pivot bracket, two "L" handles, and one 0 degree structural pivot nub. The shoulder bolt and nylon thrust washers are also included. The brackets have permanently lubricated bronze bushings that act as high-strength pivot points. It offers a high load capacity while ensuring a long life cycle.

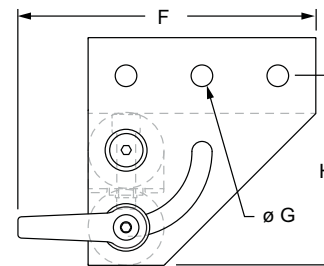
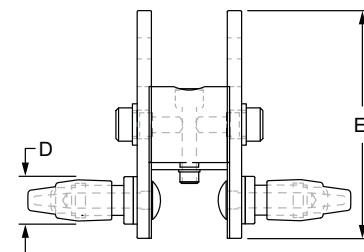
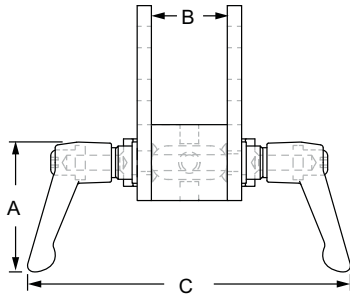

Part No.	Series	Plate (Qty.)	Nub (Qty.)	Handle (Qty.)	Color	A	B	C	D	E	F	G	H	Weight
4116	10	4133 (1) 4137 (1)	4187 (1)	2796 (2)	Clear	2.041"	1.000"	4.508"	.541"	3.000"	4.270"	.281"	2.500"	.452 lb
4116-Black	10	4133 (1) 4137 (1)	4187 (1)	2796 (2)	Black	2.041"	1.000"	4.508"	.541"	3.000"	4.270"	.281"	2.500"	.452 lb
4317	15	4333 (1) 4337 (1)	4387 (1)	2797 (2)	Clear	3.505"	1.500"	6.530"	.871"	4.500"	6.820"	.328"	3.750"	1.721 lb
4317-Black	15	4333 (1) 4337 (1)	4387 (1)	2797 (2)	Black	3.505"	1.500"	6.530"	.871"	4.500"	6.820"	.328"	3.750"	1.721 lb
25-4116	25	25-4133 (1) 25-4137 (1)	25-4187 (1)	25-2796 (2)	Clear	51.84mm	25.00mm	113.48mm	13.77mm	75.00mm	107.46mm	6.50mm	62.50mm	.1845 kg
25-4116-Black	25	25-4133 (1) 25-4137 (1)	25-4187 (1)	25-2796 (2)	Black	51.84mm	25.00mm	113.48mm	13.77mm	75.00mm	107.46mm	6.50mm	62.50mm	.1845 kg
40-4317	40	40-4333 (1) 40-4337 (1)	40-4387 (1)	40-2797 (2)	Clear	89.03mm	40.00mm	167.06mm	22.12mm	120.00mm	177.98mm	8.48mm	100.00mm	.8179 kg
40-4317-Black	40	40-4333 (1) 40-4337 (1)	40-4387 (1)	40-2797 (2)	Black	89.03mm	40.00mm	167.06mm	22.12mm	120.00mm	177.98mm	8.48mm	100.00mm	.8179 kg

Material Specifications

Material	Alloy*	Finish
Aluminum	6105-T5	Anodize

* Or comparable

Suggested Hardware (Mount to T-Slot)

Part No.	Series	Qty.	Bolt	T-Nut
3321	10	6	1/4-20 x 1/2" FBHSCS	Economy
3320	15	6	5/16-18 x 5/8" FBHSCS	
75-3404	25	6	M6 x 10mm BHSCS	
75-3422	40	6	M8 x 16mm BHSCS	

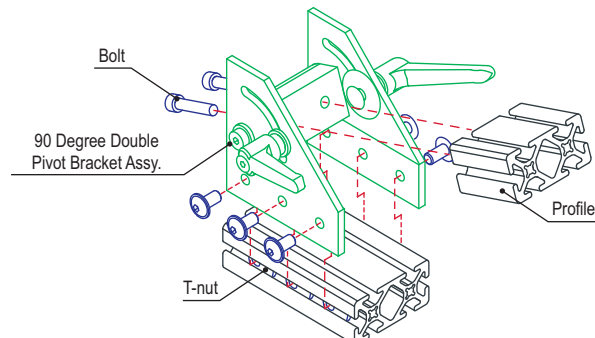

90 Degree Double Pivot Bracket Assembly with "T" Handles

Part Description:

The 90 degree double pivot bracket assembly with "T" handles is commonly used to add motion to certain elements of your project. It is comprised of one 90 degree left hand pivot bracket, one 90 degree right hand pivot bracket, two "T" handles, and one 0 degree structural pivot nub. The shoulder bolt and nylon thrust washers are also included. The brackets have permanently lubricated bronze bushings that act as high-strength pivot points. It offers a high load capacity while ensuring a long life cycle.

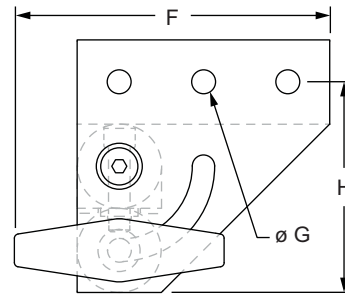
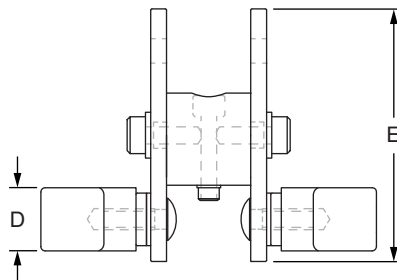
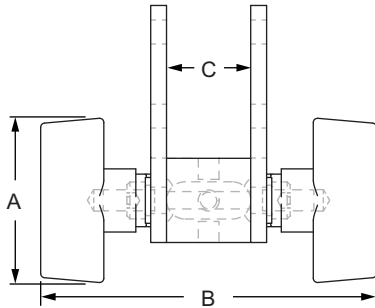

Part No.	Series	Plate (Qty.)	Nub (Qty.)	Handle (Qty.)	Color	A	B	C	D	E	F	G	H	Weight
4130	10	4133 (1) 4137 (1)	4187 (1)	2798 (2)	Clear	2.490"	3.986"	1.000"	.750"	3.000"	3.745"	.281"	2.500"	.464 lb
4130-Black	10	4133 (1) 4137 (1)	4187 (1)	2798 (2)	Black	2.490"	3.986"	1.000"	.750"	3.000"	3.745"	.281"	2.500"	.464 lb
4319	15	4333 (1) 4337 (1)	4387 (1)	2799 (2)	Clear	2.490"	4.454"	1.500"	.750"	4.500"	5.245"	.328"	3.750"	.954 lb
4319-Black	15	4333 (1) 4337 (1)	4387 (1)	2799 (2)	Black	2.490"	4.454"	1.500"	.750"	4.500"	5.245"	.328"	3.750"	.954 lb

Material Specifications

Material	Alloy*	Finish
Aluminum	6105-T5	Anodize

* Or comparable

Suggested Hardware (Mount to T-Slot)

Part No.	Series	Qty.	Bolt	T-Nut
3321	10	6	1/4-20 x 1/2" FBHSCS	Economy
3320	15	6	5/16-18 x 5/8" FBHSCS	

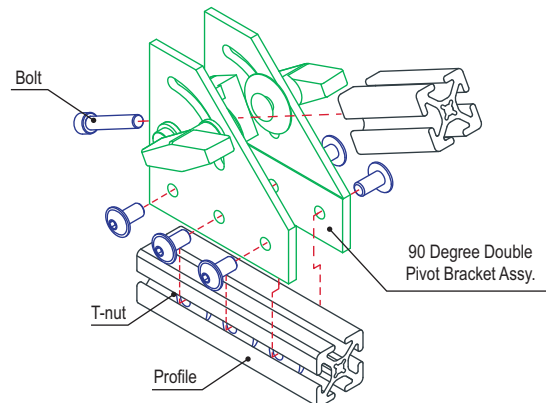



90 Degree Wide Double Pivot Bracket Assembly with "L" Handles

Part Description:

The 90 degree wide double pivot bracket assembly with "L" handles is commonly used to add motion to certain elements of your project. It is comprised of one 90 degree left hand pivot bracket, one 90 degree right hand pivot bracket, two "L" handles, and one universal structural pivot nub. The shoulder bolt and nylon thrust washers are also included. The brackets have permanently lubricated bronze bushings that act as high-strength pivot points. It offers a high load capacity while ensuring a long life cycle.

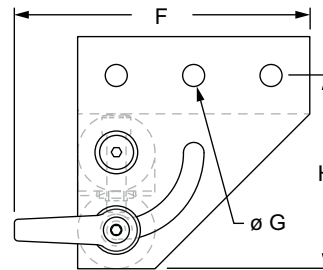
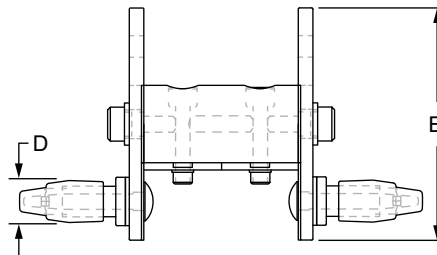
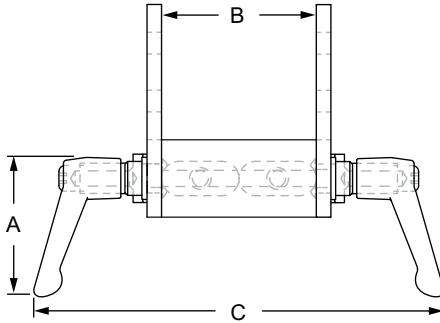

Part No.	Series	Plate (Qty.)	Nub (Qty.)	Handle (Qty.)	Color	A	B	C	D	E	F	G	H	Weight
4124	10	4133 (1) 4137 (1)	4186 (1)	2796 (2)	Clear	2.041"	2.000"	5.508"	.541"	3.000"	4.270"	.281"	2.500"	.550 lb
4124-Black	10	4133 (1) 4137 (1)	4186 (1)	2796 (2)	Black	2.041"	2.000"	5.508"	.541"	3.000"	4.270"	.281"	2.500"	.550 lb
4318	15	4333 (1) 4337 (1)	4386 (1)	2797 (2)	Clear	3.505"	3.000"	8.030"	.871"	4.500"	6.820"	.328"	3.750"	2.053 lb
4318-Black	15	4333 (1) 4337 (1)	4386 (1)	2797 (2)	Black	3.505"	3.000"	8.030"	.871"	4.500"	6.820"	.328"	3.750"	2.053 lb
25-4124	25	25-4133 (1) 25-4137 (1)	25-4186 (1)	25-2796 (2)	Clear	51.84mm	50.00mm	138.48mm	13.77mm	75.00mm	107.46mm	6.50mm	62.50mm	.2287 kg
25-4124-Black	25	25-4133 (1) 25-4137 (1)	25-4186 (1)	25-2796 (2)	Black	51.84mm	50.00mm	138.48mm	13.77mm	75.00mm	107.46mm	6.50mm	62.50mm	.2287 kg
40-4318	40	40-4333 (1) 40-4337 (1)	40-4386 (1)	40-2797 (2)	Clear	89.03mm	80.00mm	207.06mm	22.12mm	120.00mm	177.98mm	8.48mm	100.00mm	.9980 kg
40-4318-Black	40	40-4333 (1) 40-4337 (1)	40-4386 (1)	40-2797 (2)	Black	89.03mm	80.00mm	207.06mm	22.12mm	120.00mm	177.98mm	8.48mm	100.00mm	.9980 kg

Material Specifications

Material	Alloy*	Finish
Aluminum	6105-T5	Anodize

* Or comparable

Suggested Hardware (Mount to T-Slot)

Part No.	Series	Qty.	Bolt	T-Nut
3321	10	6	1/4-20 x 1/2" FBHSCS	Economy
3320	15	6	5/16-18 x 5/8" FBHSCS	
75-3404	25	6	M6 x 10mm BHSCS	
75-3422	40	6	M8 x 16mm BHSCS	

90 Degree Wide Double Pivot Bracket Assembly with "T" Handles

Part Description:

The 90 degree wide double pivot bracket assembly with "T" handles is commonly used to add motion to certain elements of your project. It is comprised of one 90 degree left hand pivot bracket, one 90 degree right hand pivot bracket, two "T" handles, and one universal structural pivot nub. The shoulder bolt and nylon thrust washers are also included. The brackets have permanently lubricated bronze bushings that act as high-strength pivot points. It offers a high load capacity while ensuring a long life cycle.

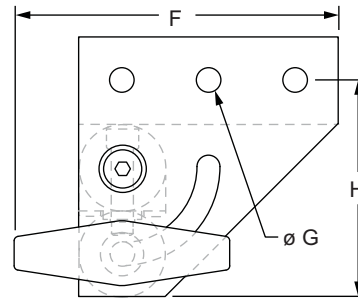
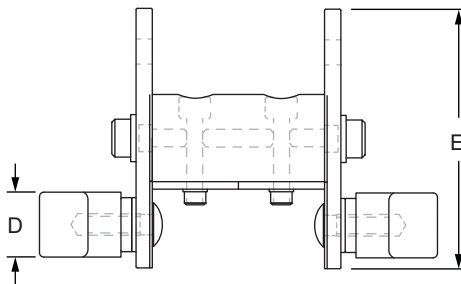
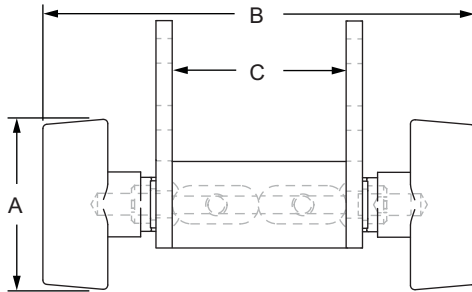

Part No.	Series	Plate (Qty.)	Nub (Qty.)	Handle (Qty.)	Color	A	B	C	D	E	F	G	H	Weight
4131	10	4133 (1) 4137 (1)	4186 (1)	2798 (2)	Clear	2.490"	4.986"	2.000"	.750"	3.000"	3.745"	.257"	2.500"	.254 lb
4131-Black	10	4133 (1) 4137 (1)	4186 (1)	2798 (2)	Black	2.490"	4.986"	2.000"	.750"	3.000"	3.745"	.257"	2.500"	.254 lb
4324	15	4333 (1) 4337 (1)	4386 (1)	2799 (2)	Clear	2.490"	5.954"	3.000"	.750"	4.500"	5.245"	.328"	3.750"	1.544 lb
4324-Black	15	4333 (1) 4337 (1)	4386 (1)	2799 (2)	Black	2.490"	5.954"	3.000"	.750"	4.500"	5.245"	.328"	3.750"	1.544 lb

Material Specifications

Material	Alloy*	Finish
Aluminum	6105-T5	Anodize

* Or comparable

Suggested Hardware (Mount to T-Slot)

Part No.	Series	Qty.	Bolt	T-Nut
3321	10	6	1/4-20 x 1/2" FBHSCS	Economy
3320	15	6	5/16-18 x 5/8" FBHSCS	

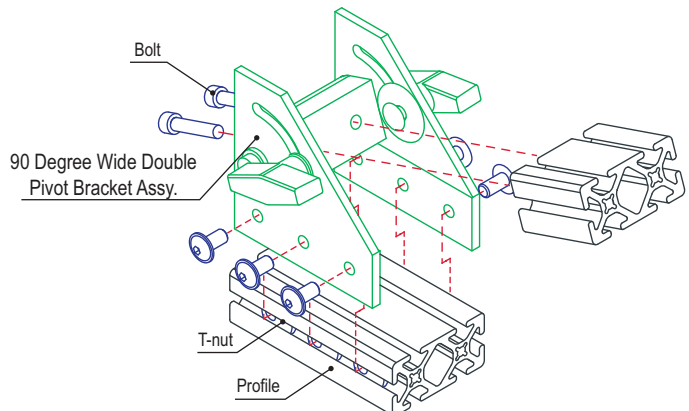



Part Description:

The 180 degree pivot bracket plate is commonly used to add motion to certain elements of your project. The plate provides a full 180 degrees of axial motion and has a permanently lubricated bronze bushing that acts as high-strength pivot point. See below for the suggested hardware to mount the plate to a profile.

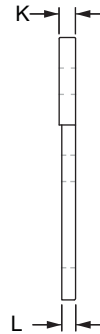
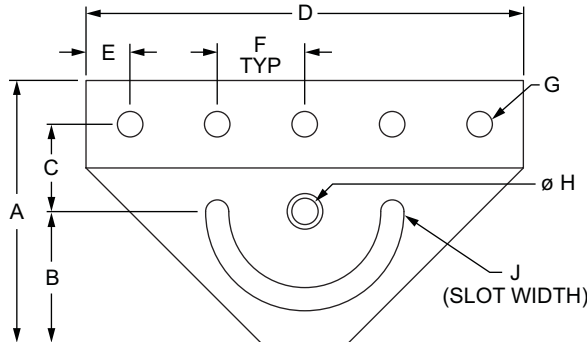

Part No.	Series	Color	A	B	C	D	E	F	G	H	J	K	L	Weight
4024	10	Clear	3.000"	1.500"	1.000"	5.000"	.500"	1.000"	.281"	.312"	.265"	.188"	.158"	.156 lb
4024-Black	10	Black	3.000"	1.500"	1.000"	5.000"	.500"	1.000"	.281"	.312"	.265"	.188"	.158"	.156 lb
4424	15	Clear	4.500"	2.250"	1.500"	7.500"	.750"	1.500"	.328"	.375"	.328"	.250"	.220"	.510 lb
4424-Black	15	Black	4.500"	2.250"	1.500"	7.500"	.750"	1.500"	.328"	.375"	.328"	.250"	.220"	.510 lb
25-4024	25	Clear	75.00mm	37.50mm	25.00mm	125.00mm	12.50mm	25.00mm	6.50mm	8.00mm	6.73mm	4.00mm	3.24mm	.0600 kg
25-4024-Black	25	Black	75.00mm	37.50mm	25.00mm	125.00mm	12.50mm	25.00mm	6.50mm	8.00mm	6.73mm	4.00mm	3.24mm	.0600 kg
40-4424	40	Clear	120.00mm	60.00mm	40.00mm	200.00mm	20.00mm	40.00mm	8.33mm	10.00mm	8.33mm	6.00mm	5.19mm	.2429 kg
40-4424-Black	40	Black	120.00mm	60.00mm	40.00mm	200.00mm	20.00mm	40.00mm	8.33mm	10.00mm	8.33mm	6.00mm	5.19mm	.2429 kg

Material Specifications

Material	Alloy*	Finish
Aluminum	6105-T5	Anodize

* Or comparable

Suggested Hardware (Mount to T-Slot)

Part No.	Series	Qty.	Bolt	T-Nut
3321	10	5	1/4-20 x 1/2" FBHSCS	Economy
3320	15	5	5/16-18 x 5/8" FBHSCS	
75-3404	25	5	M6 x 10mm BHSCS	
75-3422	40	5	M8 x 16mm BHSCS	

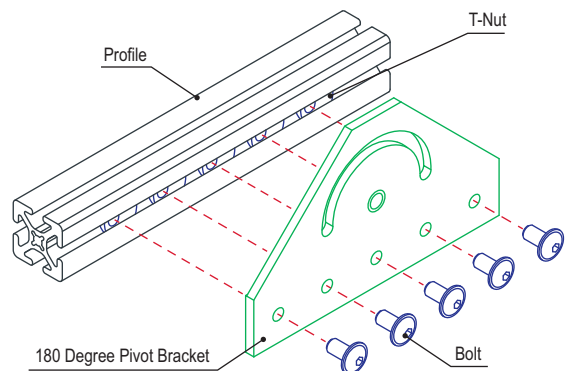

180 Degree Right Hand Pivot Bracket Assembly with "L" Handle

Part Description:

The 180 degree right hand pivot bracket assembly with "L" handle is commonly used to add motion to certain elements of your project. It is comprised of one 180 degree pivot bracket, one "L" handle, and one 0 degree structural pivot nub. The shoulder bolt and nylon thrust washers are also included. The bracket has a permanently lubricated bronze bushing that acts as high-strength pivot point. It offers a high load capacity while ensuring a long life cycle.

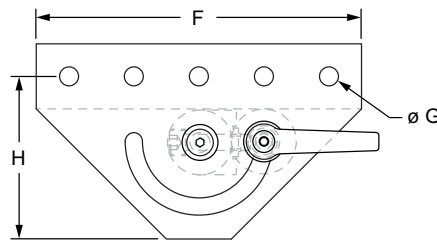
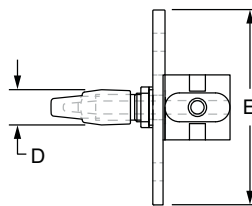
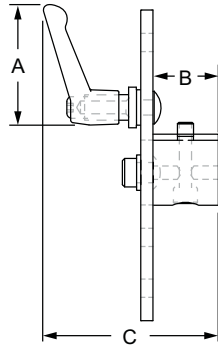

Part No.	Series	Plate (Qty.)	Nub (Qty.)	Handle (Qty.)	Color	A	B	C	D	E	F	G	H	Weight
4051	10	4024 (1)	4187 (1)	2796 (1)	Clear	2.041"	1.000"	2.755"	.541"	3.000"	5.000"	.281"	2.500"	.339 lb
4051-Black	10	4024 (1)	4187 (1)	2796 (1)	Black	2.041"	1.000"	2.755"	.541"	3.000"	5.000"	.281"	2.500"	.339 lb
4451	15	4424 (1)	4387 (1)	2797 (1)	Clear	3.505"	1.500"	4.015"	.871"	4.500"	7.500"	.328"	3.750"	1.199 lb
4451-Black	15	4424 (1)	4387 (1)	2797 (1)	Black	3.505"	1.500"	4.015"	.871"	4.500"	7.500"	.328"	3.750"	1.199 lb
25-4051	25	25-4024 (1)	25-4187 (1)	25-2796 (1)	Clear	51.84mm	25.00mm	69.24mm	13.77mm	75.00mm	125.00mm	6.50mm	62.50mm	.1375 kg
25-4051-Black	25	25-4024 (1)	25-4187 (1)	25-2796 (1)	Black	51.84mm	25.00mm	69.24mm	13.77mm	75.00mm	125.00mm	6.50mm	62.50mm	.1375 kg
40-4451	40	40-4424 (1)	40-4387 (1)	40-2797 (1)	Clear	89.03mm	40.00mm	103.53mm	22.12mm	120.00mm	200.00mm	8.48mm	100.00mm	.5824 kg
40-4451-Black	40	40-4424 (1)	40-4387 (1)	40-2797 (1)	Black	89.03mm	40.00mm	103.53mm	22.12mm	120.00mm	200.00mm	8.48mm	100.00mm	.5824 kg

Material Specifications

Material	Alloy*	Finish
Aluminum	6105-T5	Anodize

* Or comparable

Suggested Hardware (Mount to T-Slot)

Part No.	Series	Qty.	Bolt	T-Nut
3321	10	5	1/4-20 x 1/2" FBHSCS	Economy
3320	15	5	5/16-18 x 5/8" FBHSCS	
75-3404	25	5	M6 x 10mm BHSCS	
75-3422	40	5	M8 x 16mm BHSCS	

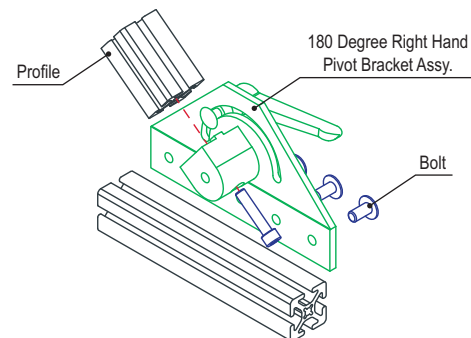



80/20® 180 Degree Double Pivot Bracket Assembly with "L" Handles

Part Description:

The 180 degree double pivot bracket assembly with "L" handles is commonly used to add motion to certain elements of your project. It is comprised of two 180 degree pivot brackets, two "L" handles, and one 0 degree structural pivot nub. The shoulder bolt and nylon thrust washers are also included. The brackets have permanently lubricated bronze bushings that act as high-strength pivot points. It offers a high load capacity while ensuring a long life cycle.

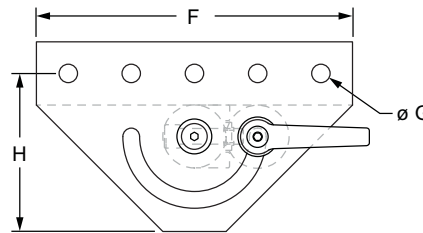
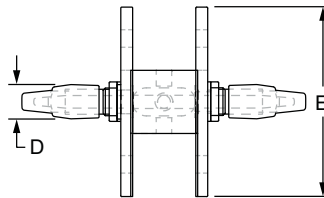
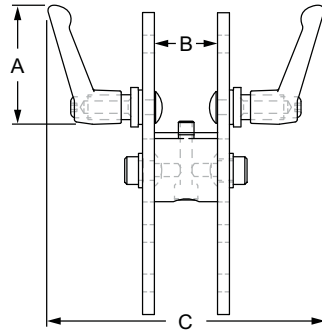

Part No.	Series	Plate (Qty.)	Nub (Qty.)	Handle (Qty.)	Color	A	B	C	D	E	F	G	H	Weight
4053	10	4024 (2)	4187 (1)	2796 (2)	Clear	2.041"	1.000"	4.510"	.541"	3.000"	5.000"	.281"	2.500"	.504 lb
4053-Black	10	4024 (2)	4187 (1)	2796 (2)	Black	2.041"	1.000"	4.510"	.541"	3.000"	5.000"	.281"	2.500"	.504 lb
4453	15	4424 (2)	4387 (1)	2797 (2)	Clear	3.505"	1.500"	6.530"	.871"	4.500"	7.500"	.328"	3.750"	2.074 lb
4453-Black	15	4424 (2)	4387 (1)	2797 (2)	Black	3.505"	1.500"	6.530"	.871"	4.500"	7.500"	.328"	3.750"	2.074 lb
25-4053	25	25-4024 (2)	25-4187 (1)	25-2796 (2)	Clear	51.84mm	25.00mm	113.48mm	13.77mm	75.00mm	125.00mm	6.50mm	62.50mm	.2304 kg
25-4053-Black	25	25-4024 (2)	25-4187 (1)	25-2796 (2)	Black	51.84mm	25.00mm	113.48mm	13.77mm	75.00mm	125.00mm	6.50mm	62.50mm	.2304 kg
40-4453	40	40-4424 (2)	40-4387 (1)	40-2797 (2)	Clear	89.03mm	40.00mm	167.06mm	22.12mm	120.00mm	200.00mm	8.48mm	100.00mm	.9970 kg
40-4453-Black	40	40-4424 (2)	40-4387 (1)	40-2797 (2)	Black	89.03mm	40.00mm	167.06mm	22.12mm	120.00mm	200.00mm	8.48mm	100.00mm	.9970 kg

Material Specifications

Material	Alloy*	Finish
Aluminum	6105-T5	Anodize

* Or comparable

Suggested Hardware (Mount to T-Slot)

Part No.	Series	Qty.	Bolt	T-Nut
3321	10	10	1/4-20 x 1/2" FBHSCS	Economy
3320	15	10	5/16-18 x 5/8" FBHSCS	
75-3404	25	10	M6 x 10mm BHSCS	
75-3422	40	10	M8 x 16mm BHSCS	

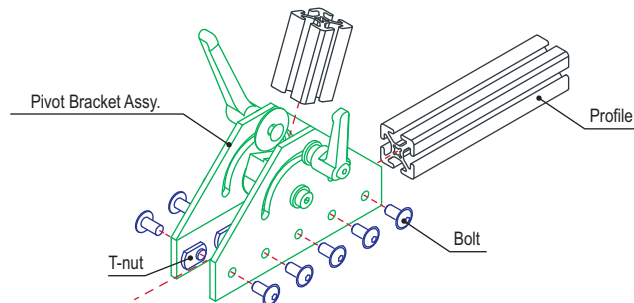

180 Degree Wide Double Pivot Bracket Assembly with "L" Handle

Part Description:

The 180 degree wide double pivot bracket assembly with "L" handle is commonly used to add motion to certain elements of your project. It is comprised of two 180 degree pivot brackets, two "L" handles, and one universal structural pivot nub. The shoulder bolt and nylon thrust washers are also included. The brackets have permanently lubricated bronze bushings that act as high-strength pivot points. It offers a high load capacity while ensuring a long life cycle.

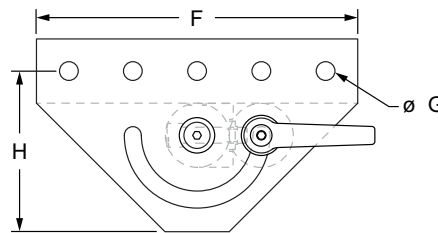
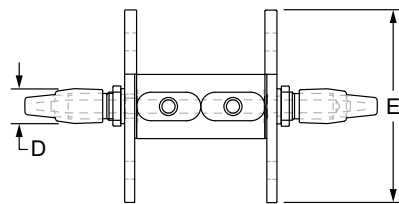
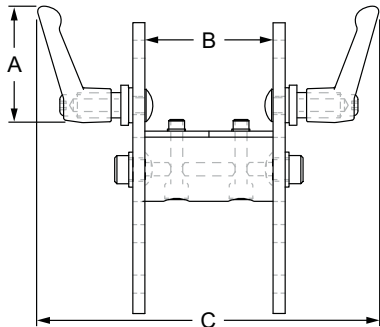

Part No.	Series	Plate (Qty.)	Nub (Qty.)	Handle (Qty.)	Color	A	B	C	D	E	F	G	H	Weight
4055	10	4024 (2)	4186 (1)	2796 (2)	Clear	2.041"	2.000"	5.510"	.541"	3.000"	5.000"	.281"	2.500"	.663 lb
4055-Black	10	4024 (2)	4186 (1)	2796 (2)	Black	2.041"	2.000"	5.510"	.541"	3.000"	5.000"	.281"	2.500"	.663 lb
4455	15	4424 (2)	4386 (1)	2797 (2)	Clear	3.505"	3.000"	8.030"	.871"	4.500"	7.500"	.328"	3.750"	2.396 lb
4455-Black	15	4424 (2)	4386 (1)	2797 (2)	Black	3.505"	3.000"	8.030"	.871"	4.500"	7.500"	.328"	3.750"	2.396 lb
25-4055	25	25-4024 (2)	25-4186 (1)	25-2796 (2)	Clear	51.84mm	50.00mm	138.48mm	13.77mm	75.00mm	125.00mm	6.50mm	62.50mm	.2744 kg
25-4055-Black	25	25-4024 (2)	25-4186 (1)	25-2796 (2)	Black	51.84mm	50.00mm	138.48mm	13.77mm	75.00mm	125.00mm	6.50mm	62.50mm	.2744 kg
40-4455	40	40-4424 (2)	40-4386 (1)	40-2797 (2)	Clear	89.03mm	80.00mm	207.06mm	22.12mm	120.00mm	200.00mm	8.48mm	100.00mm	1.1660 kg
40-4455-Black	40	40-4424 (2)	40-4386 (1)	40-2797 (2)	Black	89.03mm	80.00mm	207.06mm	22.12mm	120.00mm	200.00mm	8.48mm	100.00mm	1.1660 kg

Material Specifications

Material	Alloy*	Finish
Aluminum	6105-T5	Anodize

* Or comparable

Suggested Hardware (Mount to T-Slot)

Part No.	Series	Qty.	Bolt	T-Nut
3321	10	10	1/4-20 x 1/2" FBHSCS	Economy
3320	15	10	5/16-18 x 5/8" FBHSCS	
75-3404	25	10	M6 x 10mm BHSCS	
75-3422	40	10	M8 x 16mm BHSCS	

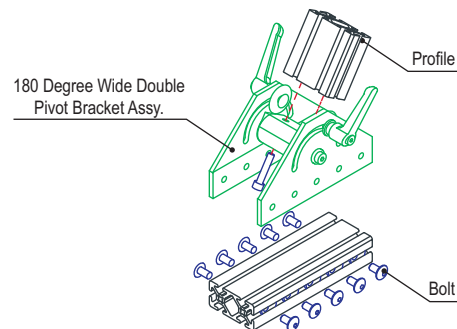

Part Description:

The "L" handle kit adds an adjustable stop to a dynamic pivot by securing it into a semi-permanent position and adds a grip to aid with adjustments. All mounting hardware is included.

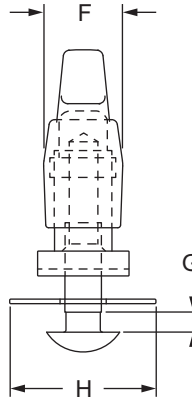
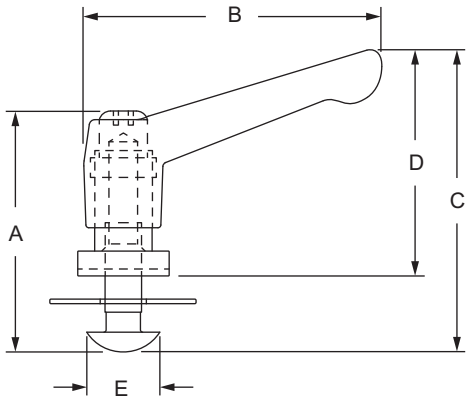

Part No.	Series	Material	Process	Finish	Color	A	B	C	D	E	F	G	H	Weight
2796	10	Nylon 66	Injection Mold	Matte	Black	1.650"	2.041"	2.070"	1.550"	.500"	.540"	.138"	1.000"	.069 lbs
2797	15	Zinc	Die Cast	Gloss	Gray	2.130"	3.505"	2.881"	2.265"	.704"	.871"	.140"	1.495"	.368 lbs
25-2796	25	Nylon 66	Injection Mold	Matte	Black	41.91mm	51.84mm	52.57mm	39.37mm	12.70mm	13.74mm	3.51mm	25.40mm	.0396 kg
40-2797	40	Zinc	Die Cast	Gloss	Gray	54.10mm	89.05mm	73.17mm	57.53mm	17.88mm	22.12mm	3.56mm	37.97mm	.1718 kg

“T” Handle Kit - Dynamic Pivot

Part Description:

The “T” handle kit adds an adjustable stop to a dynamic pivot by securing it into a semi-permanent position and adds a grip to aid with adjustments. All mounting hardware is included.

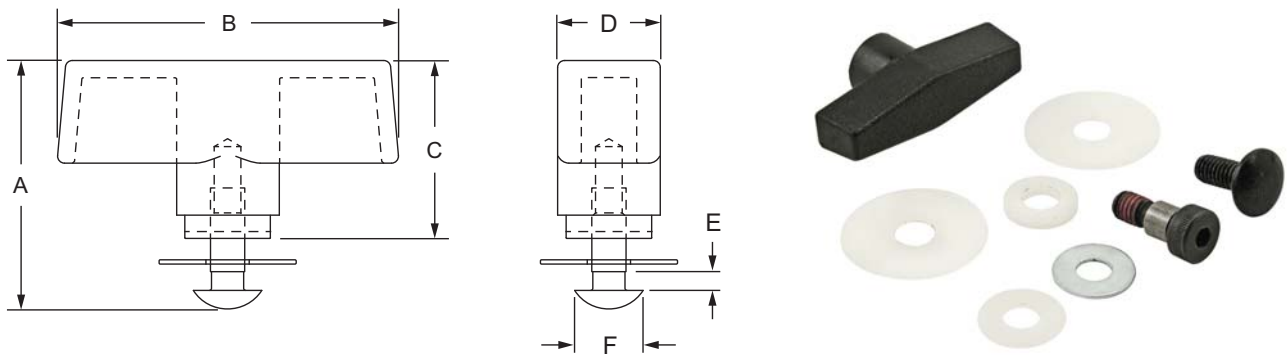

Part No.	Series	A	B	C	D	E	F	Weight
2798	10	1.815"	2.490"	1.300"	.750"	.138"	.500"	.078 lbs
2799	15	1.815"	2.490"	1.225"	.750"	.140"	.704"	.116 lbs
25-2798	25	46.10mm	63.26mm	33.02mm	19.05mm	3.51mm	12.70mm	.0445 kg
40-2799	40	46.76mm	63.26mm	31.12mm	19.05mm	3.56mm	17.88mm	.0505 kg

Material Specifications

Material	Finish	Color
Steel / Polypropylene	Zinc / Matte	Black

Introduction to Pressure Manifolds

Manifolds are used to add a pressurized substance, such as liquids or air, into the center cavity of a T-slot profile. You'll commonly find this in material handling processes, such as work and assembly stations, because the pressurized profile allows you to incorporate pneumatic tools directly into the work area.

There are a range of access, feed, and stopper plates available to fit your structure.

As an example, a manifold configuration could include an access plate attached to the supply line and feed plate mounted where the pressurized substance is released. The stopper plate secures to the profile end to form a tight seal.



DID YOU KNOW?

80/20 carries a wide range of structural shapes that allow you to design a customized manifold.

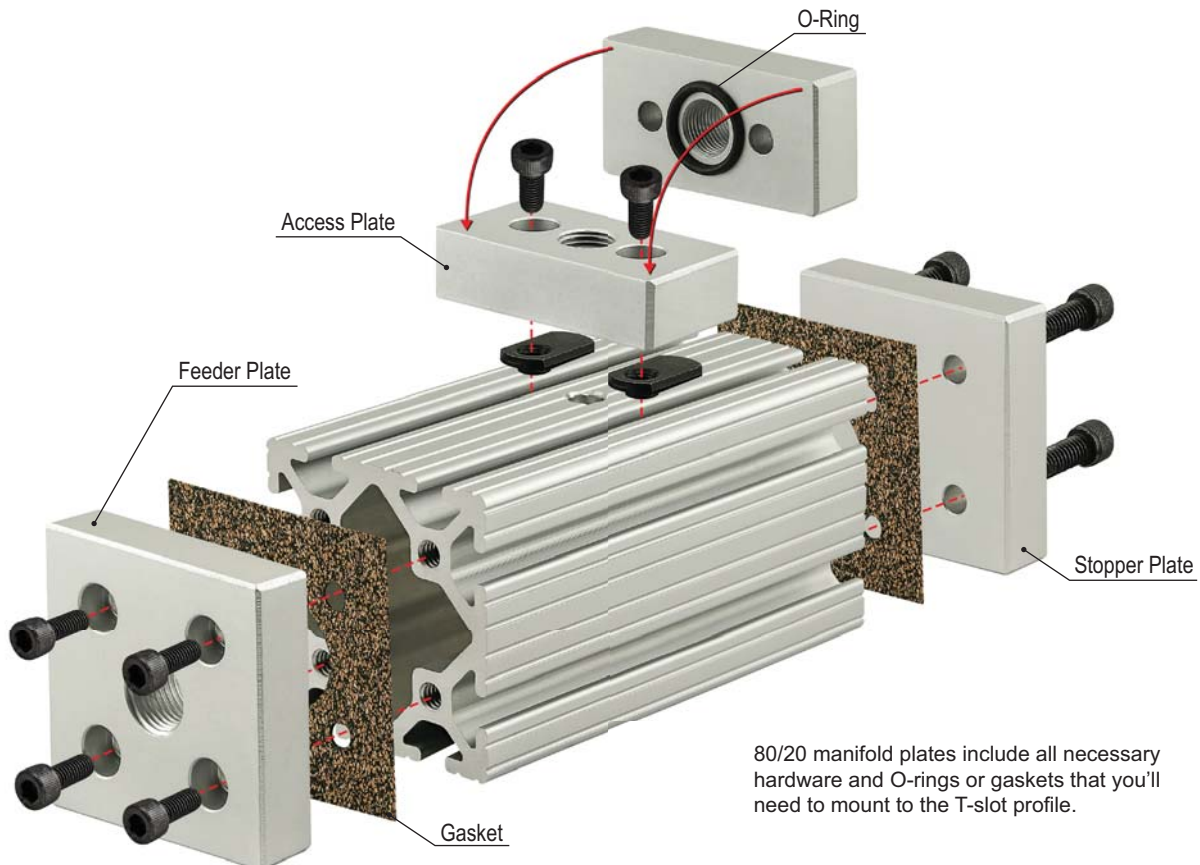

80/20 manifold plates include all necessary hardware and O-rings or gaskets that you'll need to mount to the T-slot profile.

Pressure Manifolds

3-Hole Pressure Manifold Feed Plate

The 3-hole pressure manifold feed plate is commonly used when adding a pressurized substance to a T-slot profile. It has a tapped hole and mounts on the profile end to seal the connection where the pressurized substance is released. The suggested mounting hardware and gasket are included. The maximum allowable pressure is 150 psi (1034.21 kPa).

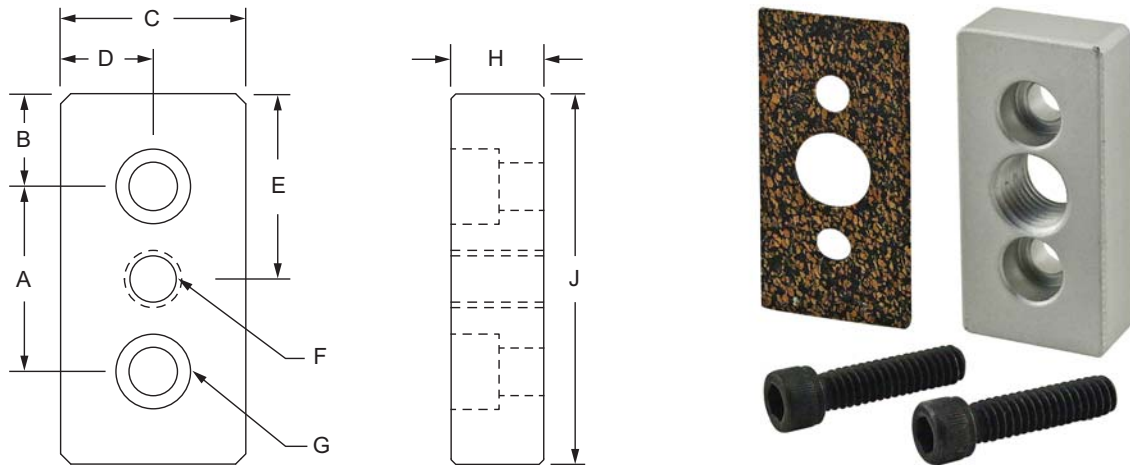

Part No.	Series	Color	A	B	C	D	E	F (Thread)	G (Bolt Size)	H	J	Weight
2151	10	Clear	1.000"	.500"	1.000"	.500"	1.000"	1/4" NPT	1/4 SHCS	.490"	2.000"	.112 lb
2151-Black	10	Black	1.000"	.500"	1.000"	.500"	1.000"	1/4" NPT	1/4 SHCS	.490"	2.000"	.112 lb
2150	15	Clear	1.500"	.750"	1.500"	.750"	1.500"	3/8" NPT	5/16 SHCS	.740"	3.000"	.339 lb
2150-Black	15	Black	1.500"	.750"	1.500"	.750"	1.500"	3/8" NPT	5/16 SHCS	.740"	3.000"	.339 lb
25-2151	25	Clear	25.00mm	12.50mm	25.00mm	12.50mm	25.00mm	1/4" NPT	M6 SHCS	11.75mm	50.00mm	.0462 kg
25-2151-Black	25	Black	25.00mm	12.50mm	25.00mm	12.50mm	25.00mm	1/4" NPT	M6 SHCS	11.75mm	50.00mm	.0462 kg
40-2150	40	Clear	40.00mm	20.00mm	40.00mm	20.00mm	40.00mm	3/8" NPT	M8 SHCS	18.75mm	80.00mm	.1697 kg
40-2150-Black	40	Black	40.00mm	20.00mm	40.00mm	20.00mm	40.00mm	3/8" NPT	M8 SHCS	18.75mm	80.00mm	.1697 kg

* Included mounting hardware and material specifications can be seen on page 751

3-Hole Gasket for Pressure Manifold

The 3-hole gasket for pressure manifold is made of a cork and synthetic rubber combination used to prevent leakage. It is used with manifold plates to completely seal a profile end or create a tight seal where a substance is released.

Part No.	Series	Color	Material	A	B	C	D	E	F	G	H	J	Weight
2152	10	Brown	velumoid	1.000"	.500"	1.000"	.500"	1.000"	.515"	.265"	.030"	2.000"	.001 lb
2153	15		CR-20	1.500"	.750"	1.500"	.750"	1.500"	.775"	.275"	.030"	3.000"	.003 lb
25-2152	25		velumoid	25.00mm	12.50mm	25.00mm	12.50mm	25.00mm	12.50mm	6.00mm	0.76mm	50.00mm	.0007 kg
40-2153	40		CR-20	40.00mm	20.00mm	40.00mm	20.00mm	40.00mm	20.00mm	7.00mm	0.76mm	80.00mm	.0018 kg

CONTINUE

2-Hole Pressure Manifold Stopper Plate

The 2-hole pressure manifold stopper plate is commonly used when adding a pressurized substance to a T-slot profile. It mounts on the profile end to form a secure seal. The suggested mounting hardware and gasket are included. The maximum allowable pressure is 150 psi (1034.21 kPa).

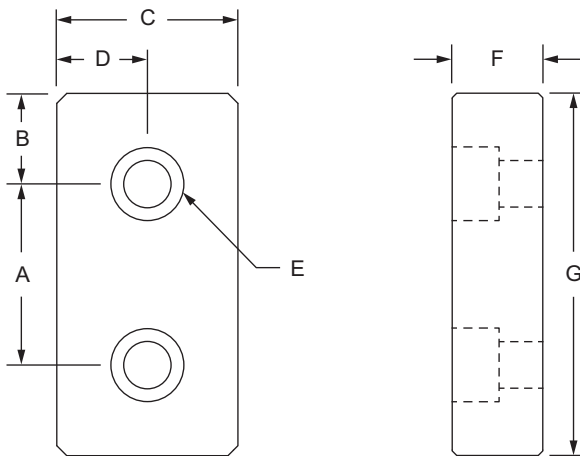

Part No.	Series	Color	A	B	C	D	E (Bolt Size)	F	G	Weight
2341	10	Clear	1.000"	.500"	1.000"	.500"	1/4 SHCS	.490"	2.000"	.120 lb
2341-Black	10	Black	1.000"	.500"	1.000"	.500"	1/4 SHCS	.490"	2.000"	.120 lb
2340	15	Clear	1.500"	.750"	1.500"	.750"	5/16 SHCS	.740"	3.000"	.362 lb
2340-Black	15	Black	1.500"	.750"	1.500"	.750"	5/16 SHCS	.740"	3.000"	.362 lb
25-2341	25	Clear	25.00mm	12.50mm	25.00mm	12.50mm	M6 SHCS	11.75mm	50.00mm	.0499 kg
25-2341-Black	25	Black	25.00mm	12.50mm	25.00mm	12.50mm	M6 SHCS	11.75mm	50.00mm	.0499 kg
40-2340	40	Clear	40.00mm	20.00mm	40.00mm	20.00mm	M8 SHCS	18.75mm	80.00mm	.1787 kg
40-2340-Black	40	Black	40.00mm	20.00mm	40.00mm	20.00mm	M8 SHCS	18.75mm	80.00mm	.1787 kg

Plate Material Specifications

Material	Alloy*	Finish	Process
Aluminum	6105-T5	Anodize	Milled

* Or comparable

Required Machining Services

Machining Type	Machined	Reference Page
Tap Profile End	Mounting Profile	853

Included Hardware (Mount to T-Slot)

Part No.	Series	Qty.	Bolt
3071	10	2	1/4-20 x 1" SHCS
3119	15	2	5/16-18 x 7/8" SHCS
13-6525	25	2	M6 x 25mm SHCS
13-8522	40	2	M8 x 22mm SHCS

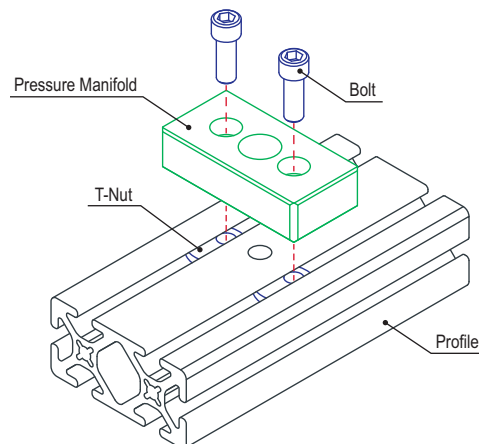

CONTINUE

Pressure Manifolds (Continued)

5-Hole Square Pressure Manifold Feed Plate

The 5-hole square pressure manifold feed plate is commonly used when adding a pressurized substance to a T-slot profile. It has a tapped hole and mounts on the profile end to seal the connection where the pressurized substance is released. The suggested mounting hardware and gasket are included. The maximum allowable pressure is 150 psi (1034.21 kPa).

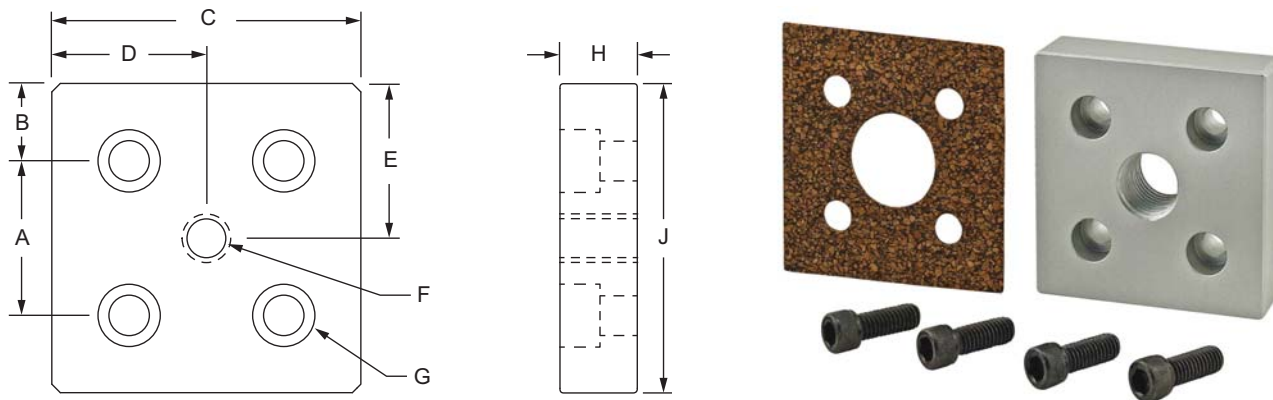

Part No.	Series	Color	A	B	C	D	E	F (Thread)	G (Bolt Size)	H	J	Weight
2159	10	Clear	1.000"	.500"	2.000"	1.000"	1.000"	3/8" NPT	1/4 SHCS	.490"	2.000"	.176 lb
2159-Black	10	Black	1.000"	.500"	2.000"	1.000"	1.000"	3/8" NPT	1/4 SHCS	.490"	2.000"	.176 lb
2160	15	Clear	1.500"	.750"	3.000"	.750"	1.500"	1/2" NPT	5/16 SHCS	.740"	3.000"	.685 lb
2160-Black	15	Black	1.500"	.750"	3.000"	.750"	1.500"	1/2" NPT	5/16 SHCS	.740"	3.000"	.685 lb
25-2159	25	Clear	25.00mm	12.50mm	50.00mm	12.50mm	25.00mm	3/8" NPT	M6 SHCS	11.75mm	50.00mm	.0938 kg
25-2159-Black	25	Black	25.00mm	12.50mm	50.00mm	12.50mm	25.00mm	3/8" NPT	M6 SHCS	11.75mm	50.00mm	.0938 kg
40-2160	40	Clear	40.00mm	20.00mm	80.00mm	20.00mm	40.00mm	1/2" NPT	M8 SHCS	18.75mm	80.00mm	.3424kg
40-2160-Black	40	Black	40.00mm	20.00mm	80.00mm	20.00mm	40.00mm	1/2" NPT	M8 SHCS	18.75mm	80.00mm	.3424 kg

* Included mounting hardware and material specifications can be seen on page 753

5-Hole Square Gasket for Pressure Manifold

The 5-hole square gasket for pressure manifold is made of a cork and synthetic rubber combination used to prevent leakage. It is used with manifold plates to completely seal a profile end or create a tight seal where a substance is released.

Part No.	Series	Color	Material	A	B	C	D	E	F	G	H	J	Weight
2154	10	Brown	CR-20	1.000"	.500"	2.000"	1.000"	1.000"	.750"	.265"	.030"	2.000"	.003 lb
2155	15			1.500"	.750"	3.000"	.750"	1.500"	1.250"	.285"	.030"	3.000"	.007 lb
25-2154	25			25.00mm	12.50mm	50.00mm	12.50mm	25.00mm	12.50mm	6.00mm	.76mm	50.00mm	.0013 kg
40-2155	40			40.00mm	20.00mm	80.00mm	20.00mm	40.00mm	33.00mm	7.00mm	.76mm	80.00mm	.0032 kg

CONTINUE

4-Hole Pressure Manifold Stopper Plate

The 4-hole pressure manifold stopper plate is commonly used when adding a pressurized substance to a T-slot profile. It mounts on the profile end to form a secure seal. The suggested mounting hardware and gasket are included. The maximum allowable pressure is 150 psi (1034.21 kPa).

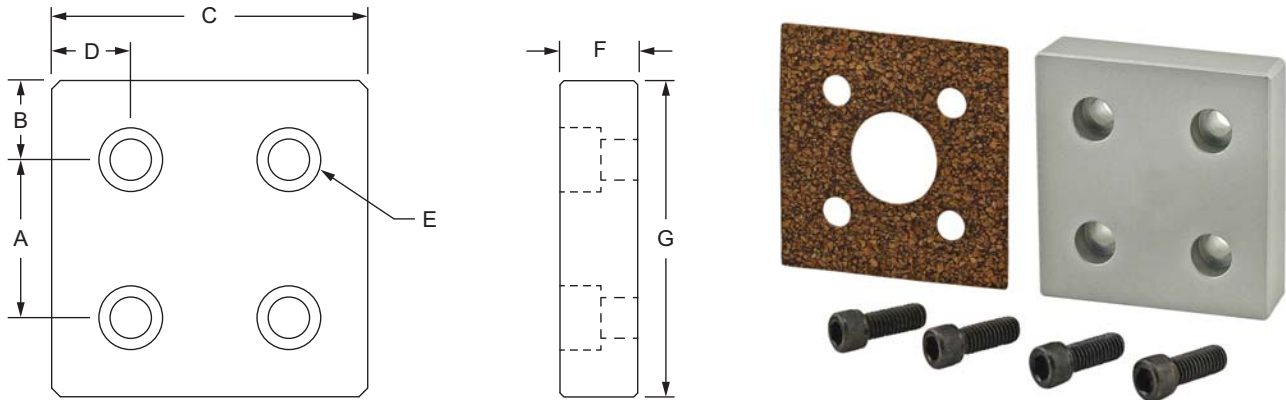

Part No.	Series	Color	A	B	C	D	E (Bolt Size)	F	G	Weight
2349	10	Clear	1.000"	.500"	2.000"	.500"	1/4 SHCS	.490"	2.000"	.238 lb
2349-Black	10	Black	1.000"	.500"	2.000"	.500"	1/4 SHCS	.490"	2.000"	.238 lb
2350	15	Clear	1.500"	.750"	3.000"	.750"	5/16 SHCS	.740"	3.000"	.721 lb
2350-Black	15	Black	1.500"	.750"	3.000"	.750"	5/16 SHCS	.740"	3.000"	.721 lb
25-2349	25	Clear	25.00mm	12.50mm	50.00mm	12.50mm	M6 SHCS	11.75mm	50.00mm	.0999 kg
25-2349-Black	25	Black	25.00mm	12.50mm	50.00mm	12.50mm	M6 SHCS	11.75mm	50.00mm	.0999 kg
40-2350	40	Clear	40.00mm	20.00mm	80.00mm	20.00mm	M8 SHCS	18.75mm	80.00mm	.3621 kg
40-2350-Black	40	Black	40.00mm	20.00mm	80.00mm	20.00mm	M8 SHCS	18.75mm	80.00mm	.3621 kg

Plate Material Specifications

Material	Alloy*	Finish	Process
Aluminum	6105-T5	Anodize	Milled

* Or comparable

Required Machining Services

Machining Type	Machined	Reference Page
Tap Profile End	Mounting Profile	853

Included Hardware (Mount to T-Slot)

Part No.	Series	Qty.	Bolt
3071	10	4	1/4-20 x 1" SHCS
3119	15	4	5/16-18 x 7/8" SHCS
13-6525	25	4	M6 x 25mm SHCS
13-8522	40	4	M8 x 22mm SHCS

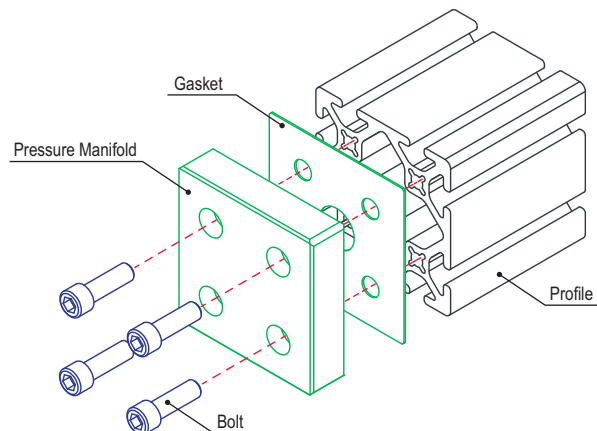

CONTINUE

Pressure Manifolds (Continued)

5-Hole Rectangular Pressure Manifold Feed Plate

The 5-hole rectangular pressure manifold feed plate is commonly used when adding a pressurized substance to a T-slot profile. It has a tapped hole and mounts on the profile end to seal the connection where the pressurized substance is released. The suggested mounting hardware and gasket are included. The maximum allowable pressure is 150 psi (1034.21 kPa).

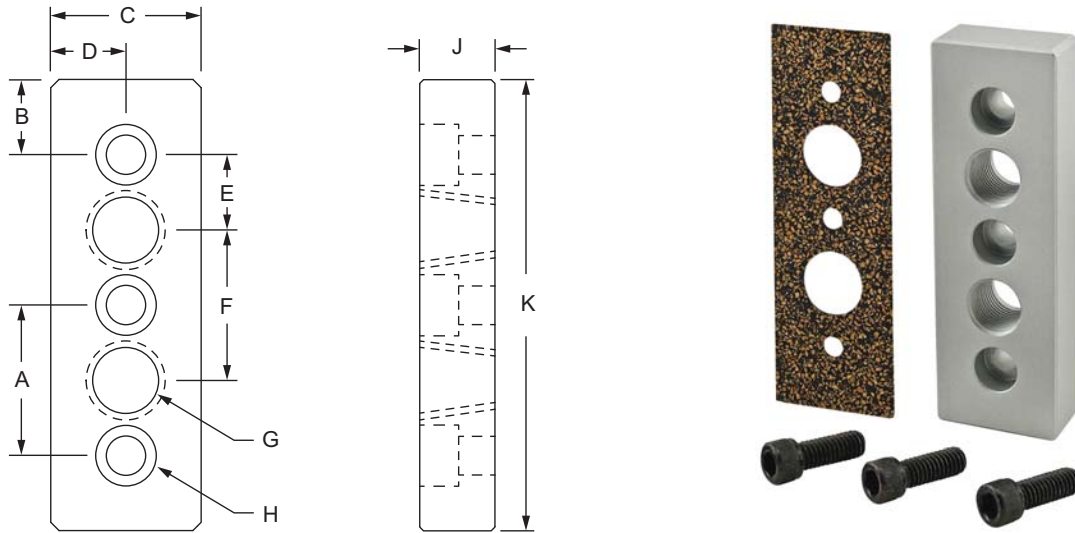

Part No.	Series	Color	A	B	C	D	E	F	G (Thread)	H (Bolt Size)	J	K	Weight
2447	10	Clear	1.000"	.500"	1.000"	.500"	.500"	1.000"	1/4" NPT	1/4 SHCS	.490"	3.000"	.161 lb
2447-Black	10	Black	1.000"	.500"	1.000"	.500"	.500"	1.000"	1/4" NPT	1/4 SHCS	.490"	3.000"	.161 lb
2162	15	Clear	1.500"	.750"	1.500"	.750"	.750"	1.500"	3/8" NPT	5/16 SHCS	.740"	4.500"	.495 lb
2162-Black	15	Black	1.500"	.750"	1.500"	.750"	.750"	1.500"	3/8" NPT	5/16 SHCS	.740"	4.500"	.495 lb

* Included mounting hardware and material specifications can be seen on page 755

5-Hole Rectangular Gasket for Pressure Manifold

The 5-hole rectangular gasket for pressure manifold is made of a cork and synthetic rubber combination used to prevent leakage. It is used with manifold plates to completely seal a profile end or create a tight seal where a substance is released.

Part No.	Series	Color	Material	A	B	C	D	E	F	G	H	J	K	Weight
2172	10	Brown	CR-20	1.000"	.500"	1.000"	.500"	.500"	1.000"	.515"	.265"	.030"	2.000"	.002 lb
2133	15			1.500"	.750"	1.500"	.750"	.750"	1.500"	.750"	.265"	.030"	4.500"	.006 lb

CONTINUE

3-Hole Pressure Manifold Stopper Plate

The 3-hole pressure manifold stopper plate is commonly used when adding a pressurized substance to a T-slot profile. It mounts on the profile end to form a secure seal. The suggested mounting hardware and gasket are included. The maximum allowable pressure is 150 psi (1034.21 kPa).

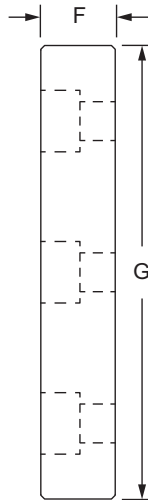
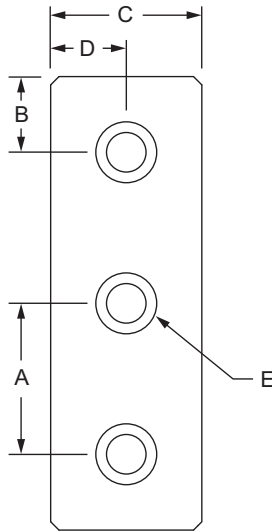

Part No.	Series	Color	A	B	C	D	E (Bolt Size)	F	G	Weight
2446	10	Clear	1.000"	.500"	1.000"	.500"	1/4 SHCS	.490"	3.000"	.178 lb
2446-Black	10	Black	1.000"	.500"	1.000"	.500"	1/4 SHCS	.490"	3.000"	.178 lb
2161	15	Clear	1.500"	.750"	1.500"	.750"	5/16 SHCS	.740"	4.500"	.540 lb
2161-Black	15	Black	1.500"	.750"	1.500"	.750"	5/16 SHCS	.740"	4.500"	.540 lb

Plate Material Specifications

Material	Alloy*	Finish	Process
Aluminum	6105-T5	Anodize	Milled

* Or comparable

Required Machining Services

Machining Type	Machined	Reference Page
Tap Profile End	Mounting Profile	853

Included Hardware (Mount to T-Slot)

Part No.	Series	Qty.	Bolt
3071	10	3	1/4-20 x 1" SHCS
3119	15	3	5/16-18 x 7/8" SHCS

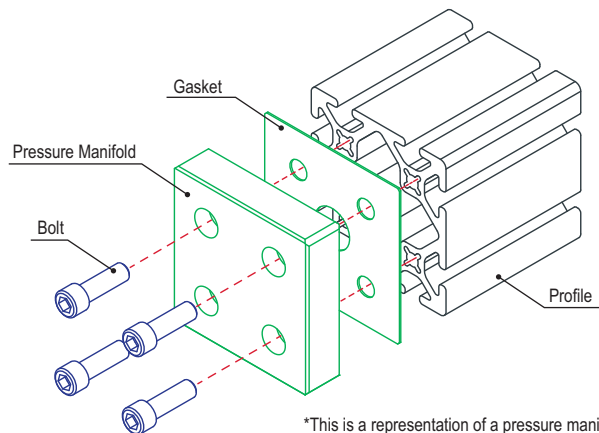

*This is a representation of a pressure manifold.

CONTINUE

Pressure Manifolds (Continued)

12-Hole Pressure Manifold Feed Plate

The 12-hole pressure manifold feed plate is commonly used when adding a pressurized substance to a T-slot profile. It has a tapped hole and mounts on the profile end to seal the connection where the pressurized substance is released. The suggested mounting hardware and gasket are included. The maximum allowable pressure is 150 psi (1034.21 kPa).

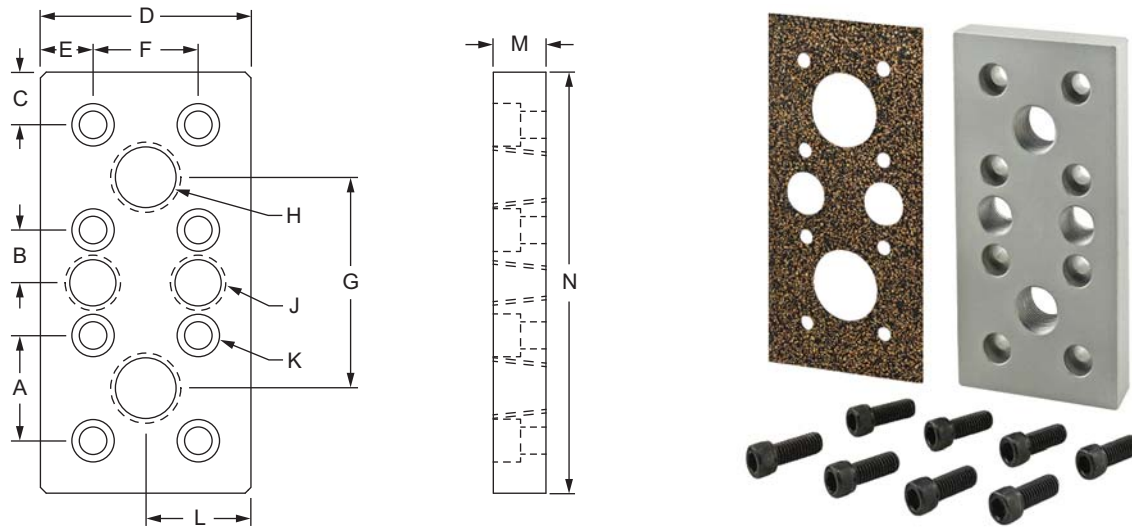

Part No.	Series	Color	A	B	C	D	E	F	G	H (Thread)	J (Thread)	K (Thread)	L	M	N	Weight
2449	10	Clear	1.000"	.500"	.500"	2.000"	.500"	1.000"	2.000"	3/8" NPT	1/4" NPT	1/4 SHCS	1.000"	.490"	4.000"	.320 lb
2449-Black	10	Black	1.000"	.500"	.500"	2.000"	.500"	1.000"	2.000"	3/8" NPT	1/4" NPT	1/4 SHCS	1.000"	.490"	4.000"	.320lb
2164	15	Clear	1.500"	.750"	.750"	3.000"	.750"	1.500"	3.000"	1/2" NPT	3/8" NPT	5/16 SHCS	1.500"	.740"	6.000"	1.328 lb
2164-Black	15	Black	1.500"	.750"	.750"	3.000"	.750"	1.500"	3.000"	1/2" NPT	3/8" NPT	5/16 SHCS	1.500"	.740"	6.000"	1.328 lb

* Included mounting hardware and material specifications can be seen on page 757

12-Hole Gasket for Pressure Manifold

The 12-hole gasket for pressure manifold is made of a cork and synthetic rubber combination used to prevent leakage. It is commonly used with manifold plates to completely seal a profile end or create a tight seal where a substance is released.

Part No.	Series	Color	Material	A	B	C	D	E	F	G	H	J	K	L	M	N	Weight
2173	10	Brown	Velumoid	1.000"	.500"	.500"	2.000"	.500"	1.000"	2.000"	.750"	.530"	.265"	1.000"	.030"	4.000"	.006 lb
2144	15	Brown	Velumoid	1.500"	.750"	.750"	3.000"	.750"	1.500"	3.000"	1.250"	.750"	.275"	1.500"	.030"	6.000"	.012 lb

CONTINUE

8-Hole Pressure Manifold Stopper Plate

The 8-hole pressure manifold stopper plate is commonly used when adding a pressurized substance to a T-slot profile. It mounts on the profile end to form a secure seal. The suggested mounting hardware and a gasket are included. The maximum allowable pressure is 150 psi (1034.21 kPa).

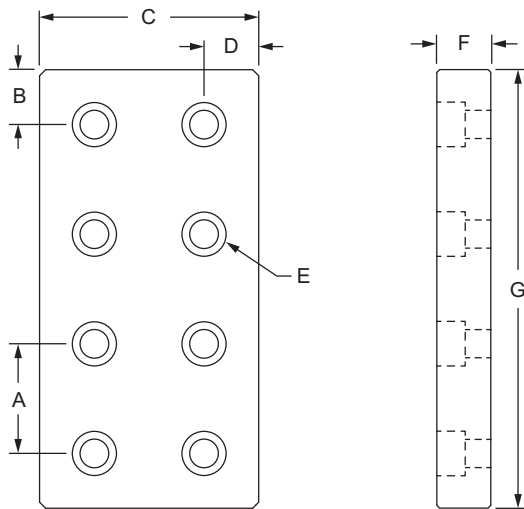

Part No.	Series	Color	A	B	C	D	E (Bolt Size)	F	G	Weight
2448	10	Clear	1.000"	.500"	2.000"	.500"	1/4 SHCS	.490"	4.000"	.472 lb
2448-Black	10	Black	1.000"	.500"	2.000"	.500"	1/4 SHCS	.490"	4.000"	.472 lb
2163	15	Clear	1.500"	.750"	3.000"	.750"	5/16 SHCS	.740"	6.000"	1.483 lb
2163-Black	15	Black	1.500"	.750"	3.000"	.750"	5/16 SHCS	.740"	6.000"	1.483 lb

Plate Material Specifications

Material	Alloy*	Finish	Process
Aluminum	6105-T5	Anodize	Milled

* Or comparable

Required Machining Services

Machining Type	Machined	Reference Page
Tap Profile End	Mounting Profile	853

Included Hardware (Mount to T-Slot)

Part No.	Series	Qty.	Bolt
3071	10	8	1/4-20 x 1" SHCS
3119	15	8	5/16-18 x 7/8" SHCS

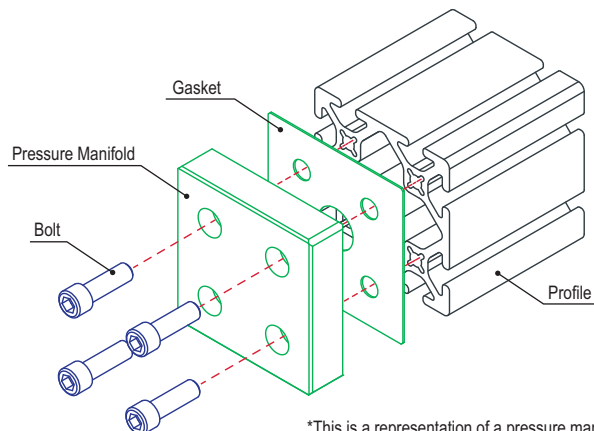

*This is a representation of a pressure manifold.

CONTINUE

Pressure Manifolds (Continued)

Pressure Manifold Access Plate

The pressure manifold access plate is commonly used when adding a pressurized substance to a T-slot profile. It has a tapped hole, mounts to the profile side, and includes an attached O-ring to provide a tight seal where the pressurized substance is released. The maximum allowable pressure is 150 psi (1034.21 kPa). The suggested mounting hardware is included.

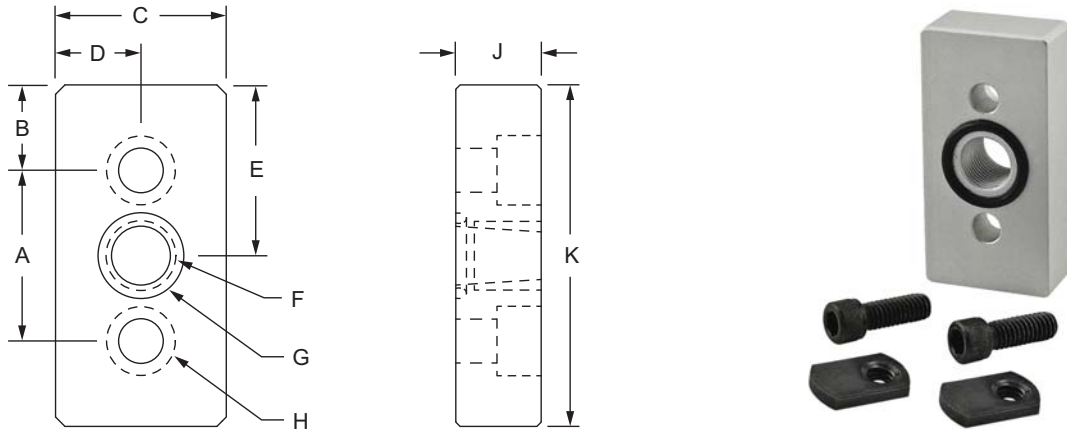

Part No.	Series	Color	A	B	C	D	E	F (Thread)	G (O-Ring Size)	H (Bolt Size)	J	K	Weight
2439	10	Clear	1.000"	.500"	1.000"	.500"	1.000"	1/8" NPT	1/2" OD	1/4 SHCS	.500"	2.000"	.126 lb
2439-Black	10	Black	1.000"	.500"	1.000"	.500"	1.000"	1/8" NPT	1/2" OD	1/4 SHCS	.500"	2.000"	.125 lb
2440	15	Clear	1.500"	.750"	1.500"	.750"	1.500"	1/4" NPT	1" OD	5/16 SHCS	.750"	3.000"	.387 lb
2440-Black	15	Black	1.500"	.750"	1.500"	.750"	1.500"	1/4" NPT	1" OD	5/16 SHCS	.750"	3.000"	.387 lb
2441	15	Clear	1.500"	.750"	1.500"	.750"	1.500"	3/8" NPT	1" OD	5/16 SHCS	.750"	3.000"	.376 lb
2441-Black	15	Black	1.500"	.750"	1.500"	.750"	1.500"	3/8" NPT	1" OD	5/16 SHCS	.750"	3.000"	.376 lb
25-2439	25	Clear	25.00mm	12.50mm	25.00mm	12.50mm	25.00mm	1/8" NPT	1/2" OD	M6 SHCS	12.00mm	50.00mm	.0524 kg
25-2439-Black	25	Black	25.00mm	12.50mm	25.00mm	12.50mm	25.00mm	1/8" NPT	1/2" OD	M6 SHCS	12.00mm	50.00mm	.0524 kg
40-2440	40	Clear	40.00mm	20.00mm	40.00mm	20.00mm	40.00mm	1/4" NPT	1" OD	M8 SHCS	19.00mm	80.00mm	.1907 kg
40-2440-Black	40	Black	40.00mm	20.00mm	40.00mm	20.00mm	40.00mm	1/4" NPT	1" OD	M8 SHCS	19.00mm	80.00mm	.1907 kg
40-2441	40	Clear	40.00mm	20.00mm	40.00mm	20.00mm	40.00mm	3/8" NPT	1" OD	M8 SHCS	19.00mm	80.00mm	.1870 kg
40-2441-Black	40	Black	40.00mm	20.00mm	40.00mm	20.00mm	40.00mm	3/8" NPT	1" OD	M8 SHCS	19.00mm	80.00mm	.1870 kg

* Included mounting hardware and material specifications can be seen on page 759

O-Ring for Pressure Manifold

The O-ring for pressure manifold is commonly used with manifold plates to completely seal a profile side or create a tight seal where a substance is released. It is used to prevent leakage.

Part No.	Series	Material	Grade	Color	A	B	Weight
2157	10	Nitrile	70 duro	Black	.500"	.062"	.0002 lb
2156	15				1.000"	.100"	.0010 lb
25-2157	25				12.70mm	1.59mm	.0001 kg
40-2156	40				25.40mm	2.54mm	.0005 kg

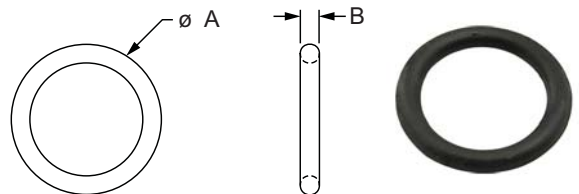

CONTINUE

Pressure Manifold Tap Ready Access Plate

The pressure manifold tap ready access plate is commonly used when adding a pressurized substance to a T-slot profile. It has a tap-ready access point, mounts to the profile side, and includes an attached O-ring to form a tight seal. The maximum allowable pressure is 150 psi (1034.21 kPa). The suggested mounting hardware is included.

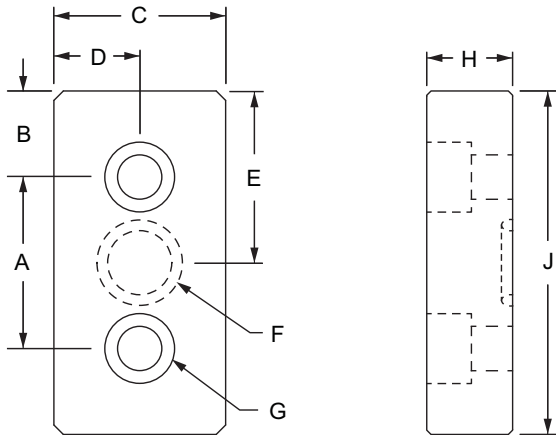

Part No.	Series	Color	A	B	C	D	E	F (O-Ring Size)	G (Bolt Size)	H	J	Weight
2451		Clear	1.000"	.500"	1.000"	.500"	1.000"	1/2" OD	1/4 SHCS	.500"	2.000"	.127 lb
2451-Black		Black	1.000"	.500"	1.000"	.500"	1.000"	1/2" OD	1/4 SHCS	.500"	2.000"	.127 lb
2450		Clear	1.500"	.750"	1.500"	.750"	1.500"	1" OD	5/16 SHCS	.750"	3.000"	.397 lb
2450-Black		Black	1.500"	.750"	1.500"	.750"	1.500"	1" OD	5/16 SHCS	.750"	3.000"	.397 lb
25-2451		Clear	25.00mm	12.50mm	25.00mm	12.50mm	25.00mm	1/2" OD	M6 SHCS	12.00mm	50.00mm	.0544 kg
25-2451-Black		Black	25.00mm	12.50mm	25.00mm	12.50mm	25.00mm	1/2" OD	M6 SHCS	12.00mm	50.00mm	.0544 kg
40-2450		Clear	40.00mm	20.00mm	40.00mm	20.00mm	40.00mm	1" OD	M8 SHCS	19.00mm	80.00mm	.1962 kg
40-2450-Black		Black	40.00mm	20.00mm	40.00mm	20.00mm	40.00mm	1" OD	M8 SHCS	19.00mm	80.00mm	.1962 kg

Plate Material Specifications

Material	Alloy*	Finish	Process
Aluminum	6105-T5	Anodize	Milled

* Or comparable

Required Machining Services

Machining Type	Machined	Reference Page
Manifold Access Profile Milling	Mounting Profile	871

Included Hardware (Mount to T-Slot)

Series	Part No.	Qty.	Bolt	Part No.	Qty.	T-Nut
	3062	2	1/4-20 x 1/2" SHCS	3382	2	Economy
	3119	2	5-16/18 x 7/8" SHCS	3278	2	Economy
	13-6512	2	M6 x 12mm SHCS	3859	2	Economy
	13-8522	2	M8 x 22mm SHCS	3838	2	Economy

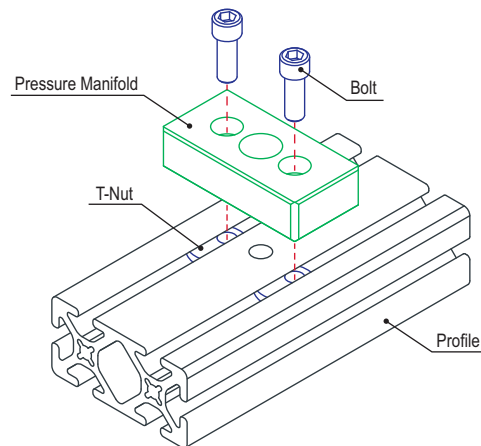

*This is a representation of a pressure manifold.

Gravity Roller

Part Description:

The gravity roller is typically used with Ready Tube™ profiles or gravity roller mounting blocks (page 761) and T-slot profiles to build custom material handling and conveyor applications. The roller has spring-loaded pins that snap easily into the holes of a Ready Tube profile. The roller is aluminum with plastic inserts, making it a strong and durable option. There are lengths available to accommodate frame openings from 15-27 inches (381-685.8mm) wide.

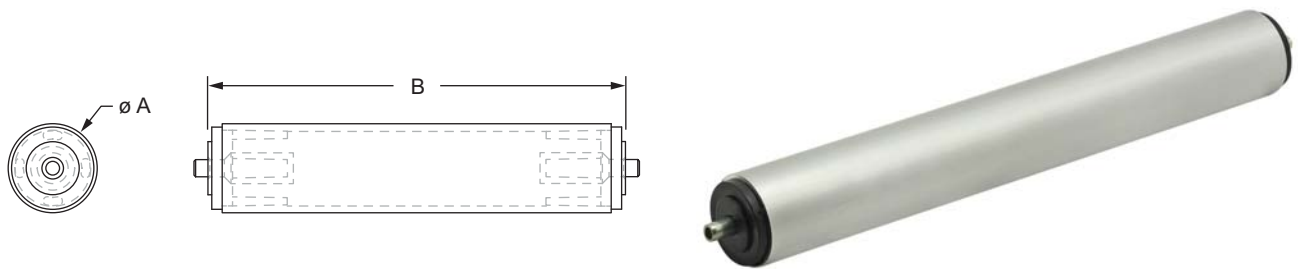

Part No.	Series	Material	Process	Finish	A	B	Weight
9840	15 40 45 RT	Aluminum / Plastic	Assembled	Clear Anodize	1.625"	11.815"	1.065 lb
9841	15 40 45 RT					13.315"	1.153 lb
9842	15 40 45 RT					14.815"	1.241 lb
9843	15 40 45 RT					16.315"	1.330 lb
9844	15 40 45 RT					17.815"	1.418 lb
9845	15 40 45 RT					19.315"	1.506 lb
9846	15 40 45 RT					20.815"	1.595 lb
9847	15 40 45 RT					23.315"	1.683 lb
9848	15 40 45 RT					23.815"	1.772 lb

Part No.	Description
9740*	Gravity Roller Tube
7010	Machining Cut Charge for 9740
7165	Two Gravity Roller Ends Assembled on Custom Length Tube

* Specify length when ordering

Part Description:

The gravity roller mounting block is made of fiberglass reinforced black nylon and is commonly used with gravity rollers (page 760) in material handling applications. The block secures in the T-slot (see suggested mounting hardware below) and the roller pin snaps in and out of the block.

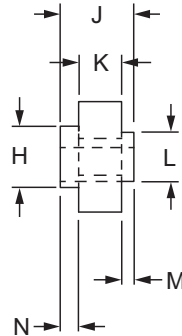
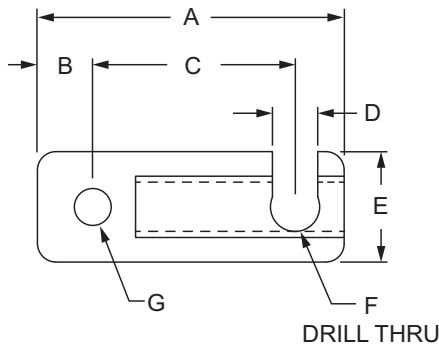

Part No.	Series	A	B	C	D	E	F	G	H	J	K	L	M	N	Weight
12167	15 40 45	1.969"	.354"	1.299"	.291"	.709"	.314"	.236"	.394"	.472"	.276"	.315"	.079"	.118"	.019 lb

Material Specifications

Material	Grade	Process	Finish
Glass Filled Nylon	PA6 GF30	Molded	Matte Black

Suggested Hardware (Mount to T-Slot)

Part No.	Series	Qty.	Bolt	T-Nut
75-3601	15 40	1	M6 x 14mm BHSCS	Drop-In
75-3482	45	1	M6 x 18mm BHSCS	Drop-In

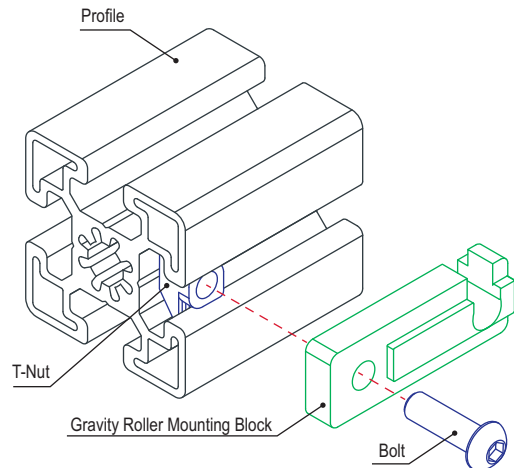
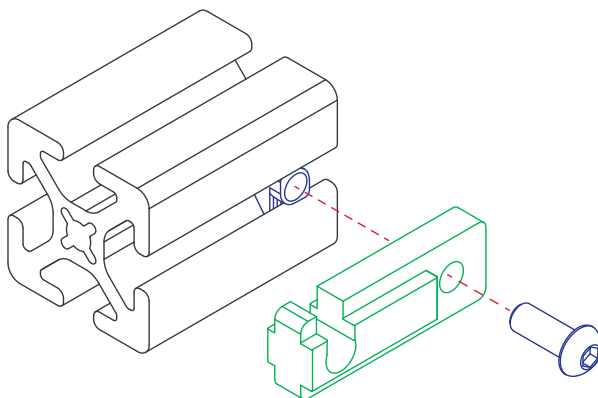

Connector Rod / Connector Rod Profile

Part Description:

The connector rod is commonly used with Ready Tube™ profiles in material handling or conveyor applications for connecting side rails on gravity roller sections. The connector rod comes in predetermined lengths or in a stock profile of 145" (3683mm). The stock profile can be cut to your desired length and tapped.

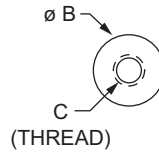
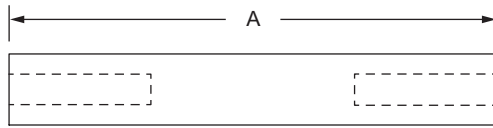

Part No.	Series	Material	Alloy*	Process	Finish	A	B	C	Weight
9821	RT	Aluminum	6105-T5	Machined	Clear Anodize	11.875"	.750"	5/16-18	0.407 lb
9822	RT					13.375"	.750"	5/16-18	0.494 lb
9823	RT					14.875"	.750"	5/16-18	0.550 lb
9824	RT					16.375"	.750"	5/16-18	0.605 lb
9825	RT					17.875"	.750"	5/16-18	0.661 lb
9826	RT					19.375"	.750"	5/16-18	0.716 lb
9827	RT					20.875"	.750"	5/16-18	0.772 lb
9828	RT					22.375"	.750"	5/16-18	0.827 lb
9829	RT					23.875"	.750"	5/16-18	0.883 lb
9830	RT					25.375"	.750"	5/16-18	0.938 lb
9831	RT					26.875"	.750"	5/16-18	0.994 lb

* Or comparable

Suggested Hardware (Mount to RT Profile)

Part No.	Series	Qty.	Bolt
3754	F	2	5/16-18 x 2.25" Flanged Hex Head Bolt

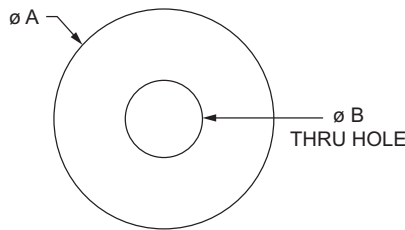

Part No.	Series	Material	Alloy*	Process	Finish	A	B	Stock Length	Weight
9820	RT	Aluminum	6105-T5	Extruded	Clear Anodize	.750"	.262"	145"	.037 lb / in.
9820-Black	RT				Black Anodize				

* Or comparable

Required Machining Services

Machining Type	Machined	Reference Page
Connector Rod End Tap	Connector Rod Profile	875

Suggested Hardware (Mount to RT Profile)

Part No.	Series	Qty.	Bolt
3754	F	2	5/16-18 x 2.25" Flanged Hex Head Bolt
13-3947	M	2	M8 x 60mm BHSCS

Part Description:

The P-tube stopper is commonly used as a material end stop on Ready Tube™ gravity rack assemblies.

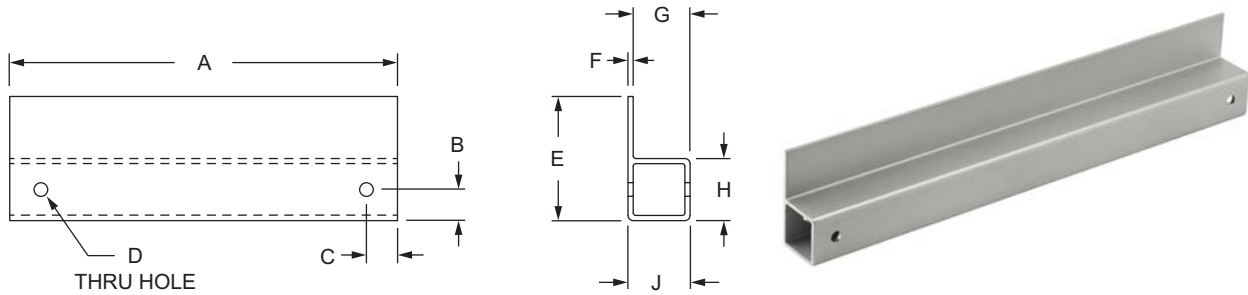

Part No.	Series	A	B	C	D	E	F	G	H	J	Weight
9860	RT	14.875"	.750"	.750"	.328"	3.000"	.125"	1.375"	1.500"	1.500"	1.197 lb
9861	RT	16.375"									1.317 lb
9862	RT	17.875"									1.436 lb
9863	RT	19.375"									1.556 lb
9864	RT	20.875"									1.676 lb
9865	RT	22.375"									1.795 lb
9866	RT	23.875"									1.915 lb
9867	RT	25.375"									2.035 lb
9868	RT	26.875"	2.155 lb								

Material Specifications

Material	Alloy*	Process	Finish
Aluminum	6105-T5	Machined	Clear Anodize

* Or comparable

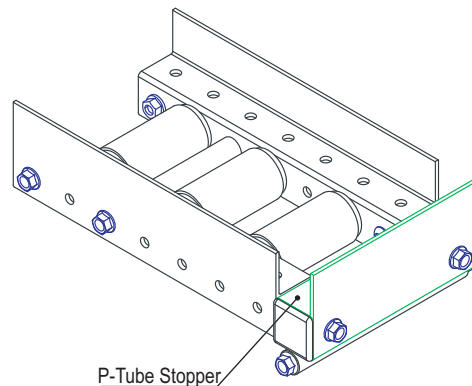

Building with Gravity Roller Components

Use the chart below starting with "A" to determine your part numbers for building a gravity roller component.

Opening "A"	Between Guide Rail Reference "B"	Connector "C" Part No.	Roller "G" Part No.	Stopper "P" Part No.	Support "S" Part No.
15.0"	11.875"	9821	9840	9860	9823
16.5"	13.375"	9822	9841	9861	9824
18.0"	14.875"	9823	9842	9862	9825
19.5"	16.375"	9824	9843	9863	9826
21.0"	17.875"	9825	9844	9864	9827
22.5"	19.375"	9826	9845	9865	9828
24.0"	20.875"	9827	9846	9866	9829
25.5"	22.375"	9828	9847	9867	9830
27.0"	23.875"	9829	9848	9868	9831

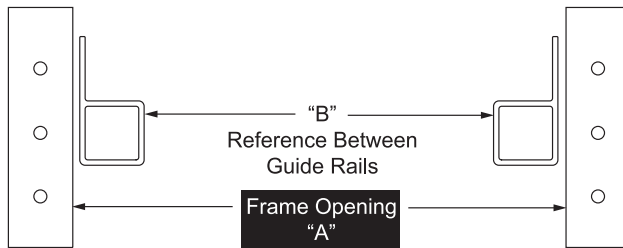

Example: If "A" = 18.00"

Part No.	Description
9823	"C" 14.875" Connector Rod
9842	"G" 14.815" Gravity Roller
9862	"P" 17.875" P-Tube Stopper
9825	"S" 17.875" Support Connector Rod

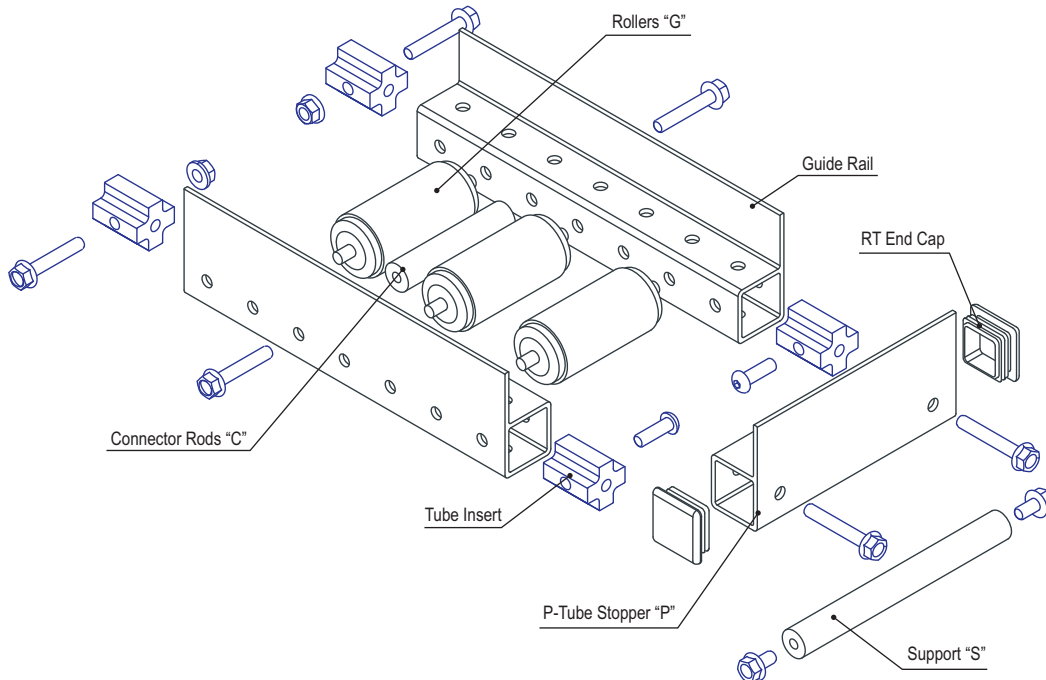

Introduction to Stanchions

Stanchions are typically used with 80/20 aluminum tubes to create an additional axis. Stanchions are a more permanent, precise, and stable base than alternatives, such as clamps.

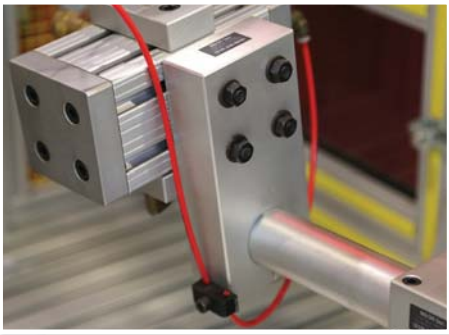
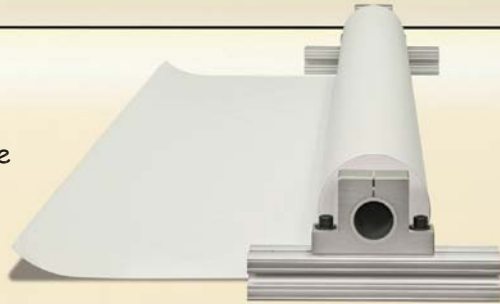

Variety of Bases

There are different bases to choose from that allow you to add vertical or horizontal axes or a combination of the two. You also have options that support two axes using just one base or even the ability to create an off-set axis.

Incorporate Tubes, Wires & Cables

You will also want to consider adding a handle to your stanchion block; they enable flexibility in positioning and easy repositioning if you will be moving the tube frequently.



Need to Know



If your project will incorporate tubes, wires or cables there are bases available with clearance holes to accommodate.



Single Shaft Stanchion Base

Part Description:

The single shaft stanchion base is commonly used with the aluminum tube profile (page 827) to create an additional axis. The tube connects parallel to the mounted base, and there is a clearance channel for running wires or cables. The base is aluminum, making it a strong and durable option. Clamp screws are included while the suggested hardware to mount the base to a T-slot can be found below.

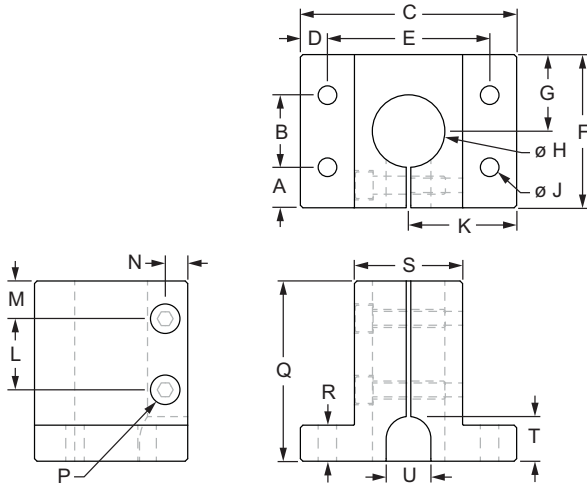

Part No.	Series	Color	Material	Alloy*	Finish	Process	A	B	C	D	E	F	G	H
5050	10	Clear	Aluminum	6105-T5	Anodize	Milled	.563"	1.000"	3.000"	.375"	2.250"	2.125"	1.063"	1.004"
5050-Black	10	Black					.563"	1.000"	3.000"	.375"	2.250"	2.125"	1.063"	1.004"
5100	15	Clear					.312"	1.500"	3.000"	.375"	2.250"	2.125"	1.063"	1.004"
5100-Black	15	Black					.312"	1.500"	3.000"	.375"	2.250"	2.125"	1.063"	1.004"
5200	15	Clear					.500"	1.500"	3.874"	.437"	3.000"	2.500"	1.250"	1.505"
5200-Black	15	Black					.500"	1.500"	3.874"	.437"	3.000"	2.500"	1.250"	1.505"
5300	15	Clear					.875"	1.500"	4.750"	.500"	3.750"	3.250"	1.625"	2.005"
5300-Black	15	Black					.875"	1.500"	4.750"	.500"	3.750"	3.250"	1.625"	2.005"
		J	K	L	M	N	P	Q	R	S	T	U	Weight	
5050	10	.257"	1.500"	.990"	.520"	.312"	1/4-20 SHCS	2.500"	.500"	1.500"	.620"	.620"	.714 lb	
5050-Black	10	.257"	1.500"	.990"	.520"	.312"	1/4-20 SHCS	2.500"	.500"	1.500"	.620"	.620"	.714 lb	
5100	15	.328"	1.500"	.990"	.520"	.312"	1/4-20 SHCS	2.500"	.500"	1.500"	.620"	.620"	.705 lb	
5100-Black	15	.328"	1.500"	.990"	.520"	.312"	1/4-20 SHCS	2.500"	.500"	1.500"	.620"	.620"	.705 lb	
5200	15	.328"	1.937"	1.110"	.580"	.302"	1/4-20 SHCS	2.500"	.750"	2.250"	.875"	.880"	1.369 lb	
5200-Black	15	.328"	1.937"	1.110"	.580"	.302"	1/4-20 SHCS	2.500"	.750"	2.250"	.875"	.880"	1.369 lb	
5300	15	.328"	2.375"	1.220"	.630"	.328"	1/4-20 SHCS	3.250"	.750"	2.750"	.750"	1.250"	2.251 lb	
5300-Black	15	.328"	2.375"	1.220"	.630"	.328"	1/4-20 SHCS	3.250"	.750"	2.750"	.750"	1.250"	2.251 lb	

* Or comparable

Suggested Hardware (Mount Stanchion to T-Slot)

Part No.	Bolt Assy.	Qty.	Bolt	T-Nut	Washer
5050	3471	4	1/4-20 x 7/8" SHCS	Economy	Yes
5100	3470	4	5/16-18 x 1" SHCS		
5200	3421	4	5/16-18 x 1.25" SHCS		
5300	3421	4	5/16-18 x 1.25" SHCS		

Part Description:

The double shaft stanchion base is commonly used with the aluminum tube profile (page 827) to create two additional axes. Tubes connect parallel to the mounted base, and there are clearance channels for running wire or cables. The stanchion is aluminum, making it a strong and durable option. Clamp screws are included while the suggested hardware to mount the base to a T-slot can be found below.

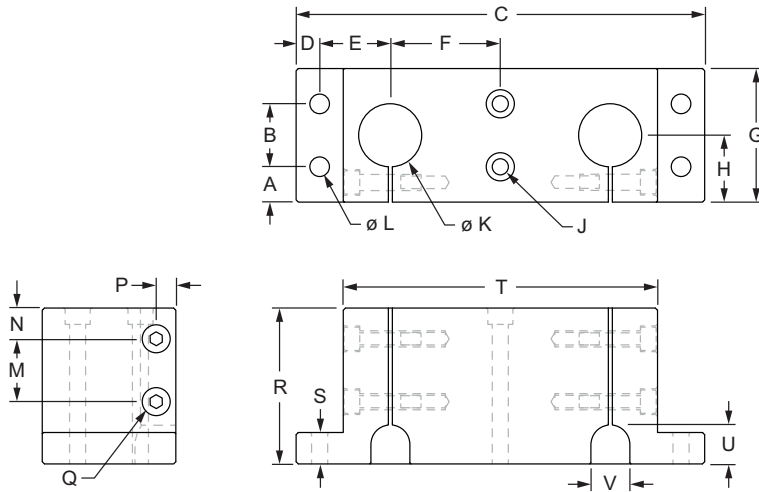

Part No.	Series	Color	Material	Alloy*	Finish	Process	A	B	C	D	E	F	G	H
5125	10	Clear	Aluminum	6105-T5	Anodize	Milled	.563"	1.000"	6.500"	.375"	1.125"	1.750"	2.125"	1.063"
5125-Black	10	Black					.563"	1.000"	6.500"	.375"	1.125"	1.750"	2.125"	1.063"
5150	15	Clear					.312"	1.500"	6.500"	.375"	1.125"	1.750"	2.125"	1.063"
5150-Black	15	Black					.312"	1.500"	6.500"	.375"	1.125"	1.750"	2.125"	1.063"
5250	15	Clear					.500"	1.500"	7.750"	.437"	1.500"	1.938"	2.500"	1.250"
5250-Black	15	Black					.500"	1.500"	7.750"	.437"	1.500"	1.938"	2.500"	1.250"
5350	15	Clear					.875"	1.500"	9.500"	.500"	1.875"	2.375"	3.250"	1.625"
5350-Black	15	Black					.875"	1.500"	9.500"	.500"	1.875"	2.375"	3.250"	1.625"
		J	K	L	M	N	P	Q	R	S	T	U	V	Weight
5125	10	1/4-20 SHCS	1.004"	.257"	1.000"	.490"	.312"	1/4-20 SHCS	2.480"	.500"	5.000"	.620"	.620"	1.878 lb
5125-Black	10	1/4-20 SHCS	1.004"	.257"	1.000"	.490"	.312"	1/4-20 SHCS	2.480"	.500"	5.000"	.620"	.620"	1.878 lb
5150	15	5/16-18 SHCS	1.004"	.328"	1.000"	.490"	.312"	1/4-20 SHCS	2.480"	.500"	5.000"	.620"	.620"	1.874 lb
5150-Black	15	5/16-18 SHCS	1.004"	.328"	1.000"	.490"	.312"	1/4-20 SHCS	2.480"	.500"	5.000"	.620"	.620"	1.874 lb
5250	15	5/16-18 SHCS	1.505"	.328"	1.110"	.560"	.302"	5/16-18 SHCS	2.980"	.750"	6.125"	.820"	.880"	3.650 lb
5250-Black	15	5/16-18 SHCS	1.505"	.328"	1.110"	.560"	.302"	5/16-18 SHCS	2.980"	.750"	6.125"	.820"	.880"	3.650 lb
5350	15	5/16-18 SHCS	2.005"	.328"	1.250"	.630"	.328"	5/16-18 SHCS	3.250"	.750"	7.500"	.750"	1.250"	6.090 lb
5350-Black	15	5/16-18 SHCS	2.005"	.328"	1.250"	.630"	.328"	5/16-18 SHCS	3.250"	.750"	7.500"	.750"	1.250"	6.090 lb

* Or comparable

Suggested Hardware (Mount Stanchion to T-Slot)

Part No.	Bolt Assy.	Qty.	Bolt	T-Nut	Washer	AND / OR	Bolt Assy.	Qty.	Bolt	T-Nut	Washer
5125	3471	4	1/4-20 x 7/8" SHCS	Economy	Yes		3434	2	1/4-20 x 2.5" SHCS	Economy	No
5150	3470	4	5/16-18 x 1" SHCS				3429	2	5/16-18 x 2.5" SHCS		
5250	3421	4	5/16-18 x 1.25" SHCS				3430	2	5/16-18 x 3" SHCS		
5350	3421	4	5/16-18 x 1.25" SHCS			3431	2	5/16-18 x 3.25" SHCS			

Single Shaft Blank Stanchion Mounting Plate

Part Description:

The single shaft blank stanchion mounting plate is commonly used with the aluminum tube profile (page 827) to create a custom offset axis. The tube connects perpendicular to the mounted base to form the stanchion. The plate is aluminum, making it a strong and durable option. Clamp screws are included.

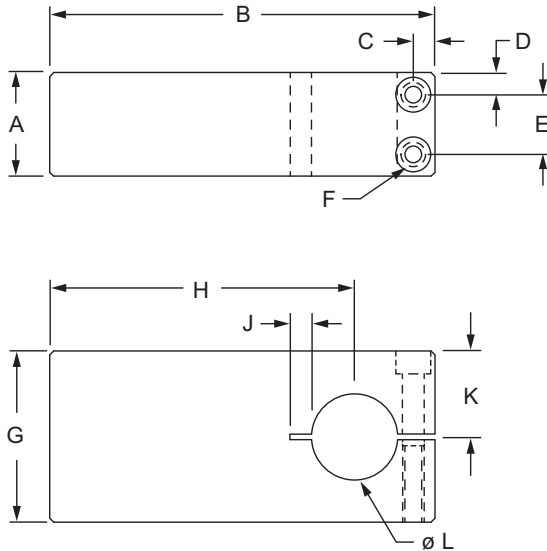

Part No.	Series	Color	Material	Alloy*	Finish	Process	A	B	C	D				
5400	10	Clear	Aluminum	6105-T5	Anodize	Milled	1.200"	4.500"	.250"	.250"				
5400-Black	10	Black					1.200"	4.500"	.250"	.250"				
5450	15	Clear					1.450"	6.500"	.325"	.350"				
5450-Black	15	Black					1.450"	6.500"	.325"	.350"				
5500	15	Clear					1.950"	7.750"	.375"	.350"				
5500-Black	15	Black					1.950"	7.750"	.375"	.350"				
							E	F	G	H	J	K	L	Weight
5400	10	.700"	1/4-20 SHCS	2.000"	3.560"	.250"	1.000"	1.004"	.964 lb					
5400-Black	10	.700"	1/4-20 SHCS	2.000"	3.560"	.250"	1.000"	1.004"	.964 lb					
5450	15	.750"	1/4-20 SHCS	3.000"	5.125"	-	1.500"	1.505"	2.501 lb					
5450-Black	15	.750"	1/4-20 SHCS	3.000"	5.125"		1.500"	1.505"	2.501 lb					
5500	15	1.250"	5/16-18 SHCS	4.000"	6.120"		2.000"	2.005"	5.310 lb					
5500-Black	15	1.250"	5/16-18 SHCS	4.000"	6.120"		2.000"	2.005"	5.310 lb					

* Or comparable

80/20[®] Inc. Single Shaft Pre-Drilled Stanchion Mounting Plate

Part Description:

The single shaft pre-drilled stanchion mounting plate is commonly used with the aluminum tube profile (page 827) to create an offset axis. The tube connects perpendicular to the mounted base to form the stanchion. The plate is aluminum, making it a strong and durable option. Clamp screws are included while the suggested hardware to mount the base to a T-slot can be found below.

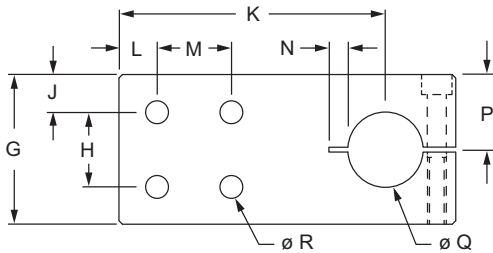
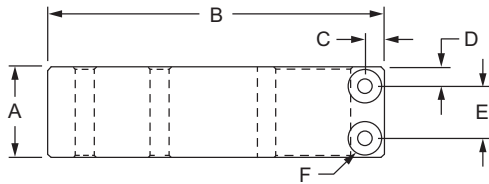

5415, 5425, 5475



5525

Part No.	Series	Color	Material	Alloy*	Finish	Process	A	B	C	D	E	F
5415	10	Clear	Aluminum	6105-T5	Anodize	Milled	1.200"	4.500"	.250"	.250"	.700"	1/4-20 SHCS
5415-Black	10	Black					1.200"	4.500"	.250"	.250"	.700"	1/4-20 SHCS
5425	15	Clear					1.200"	4.500"	.250"	.250"	.700"	1/4-20 SHCS
5425-Black	15	Black					1.200"	4.500"	.250"	.250"	.700"	1/4-20 SHCS
5475	15	Clear					1.450"	6.500"	.328"	.350"	.750"	1/4-20 SHCS
5475-Black	15	Black					1.450"	6.500"	.328"	.350"	.750"	1/4-20 SHCS
5525	15	Clear					1.950"	7.750"	.375"	.350"	1.250"	5/16-18 SHCS
5525-Black	15	Black					1.950"	7.750"	.375"	.350"	1.250"	5/16-18 SHCS
		G	H	J	K	L	M	N	P	Q	R	Weight
5415	10	2.000"	1.000"	.500"	3.560"	.500"	1.000"	.250"	1.000"	1.004"	.257"	.946 lb
5415-Black	10	2.000"	1.000"	.500"	3.560"	.500"	1.000"	.250"	1.000"	1.004"	.257"	.946 lb
5425	15	2.000"	1.500"	.250"	3.560"	.500"	1.500"	.250"	1.000"	1.004"	.328"	.936 lb
5425-Black	15	2.000"	1.500"	.250"	3.560"	.500"	1.500"	.250"	1.000"	1.004"	.328"	.936 lb
5475	15	3.000"	1.500"	.750"	5.125"	.750"	1.500"	-	1.500"	1.505"	.328"	2.494 lb
5475-Black	15	3.000"	1.500"	.750"	5.125"	.750"	1.500"		1.500"	1.505"	.328"	2.494 lb
5525	15	4.000"	1.500"	1.250"	6.120"	.750"	1.500"	-	2.000"	2.005"	.328"	5.220 lb
5525-Black	15	4.000"	1.500"	1.250"	6.120"	.750"	1.500"		2.000"	2.005"	.328"	5.220 lb

* Or comparable

Suggested Hardware (Mount Stanchion to T-Slot)

Part No.	Bolt Assy.	Qty.	Bolt	T-Nut	Washer
5415	3432	4	1/4-20 x 1.5" SHCS	Economy	Yes
5425	3423	4	5/16-18 x 1.75" SHCS		
5475	3424	4	5/16-18 x 2" SHCS		
5525	3428	6	5/16-18 x 2.5" SHCS		

Double Shaft Blank Stanchion Mounting Plate

Part Description:

The double shaft blank stanchion mounting plate is commonly used with the aluminum tube profile (page 827) to create custom double offset axes. Tubes connect perpendicular to the mounted base to form the stanchions. The plate is aluminum, making it a strong and durable option. Clamp screws are included.

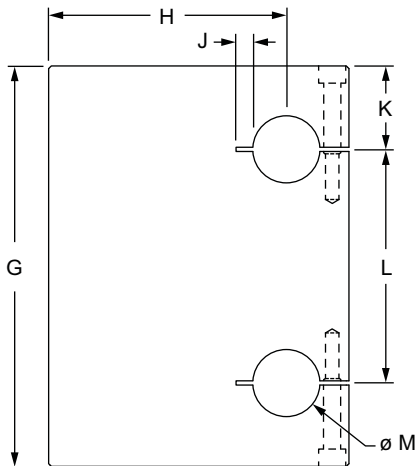
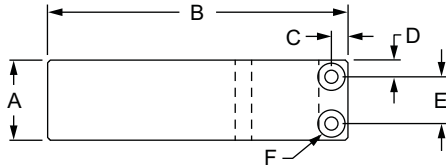

Part No.	Series	Color	Material	Alloy*	Finish	Process	A	B	C	D
5700	15	Clear	Aluminum	6105-T5	Anodize	Milled	1.200"	4.500"	.250"	.250"
5700-Black	15	Black					1.200"	4.500"	.250"	.250"
5750	15	Clear					1.450"	5.500"	.328"	.350"
5750-Black	15	Black					1.450"	5.500"	.328"	.350"
		E	F	G	H	J	K	L	M	Weight
5700	15	.700"	1/4-20 SHCS	6.000"	3.560"	.250"	1.250"	3.500"	1.004"	3.034 lb
5700-Black	15	.700"	1/4-20 SHCS	6.000"	3.560"	.250"	1.250"	3.500"	1.004"	3.034 lb
5750	15	.750"	1/4-20 SHCS	6.000"	4.125"	—	1.062"	3.875"	1.505"	4.180 lb
5750-Black	15	.750"	1/4-20 SHCS	6.000"	4.125"	—	1.062"	3.875"	1.505"	4.180 lb

* Or comparable

80/20[®] Inc. Double Shaft Pre-Drilled Stanchion Mounting Plate

Part Description:

The double shaft pre-drilled stanchion mounting plate is commonly used with the aluminum tube profile (page 827) to create double offset axes. Tubes connect perpendicular to the mounted base to form the stanchions. The plate is aluminum, making it a strong and durable option. Clamp screws are included while the suggested hardware to mount the base to a T-slot can be found below.

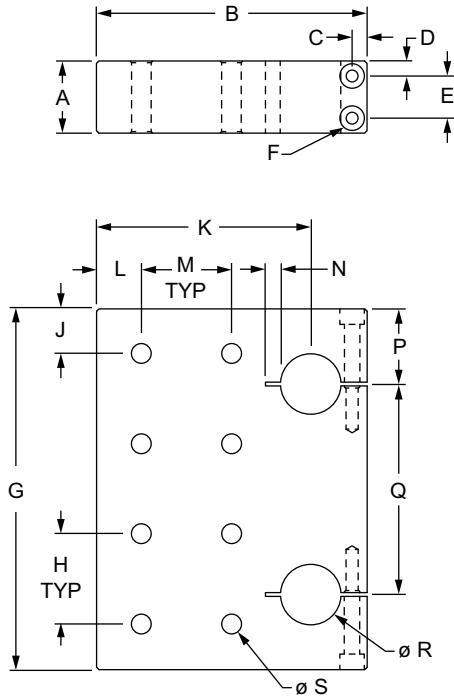

Part No.	Series	Color	Material	Alloy*	Finish	Process	A	B	C	D	E	F	G
5725	15	Clear	Aluminum	6105-T5	Anodize	Milled	1.200"	4.500"	.250"	.250"	.700"	1/4-20 SHCS	6.000"
5725-Black	15	Black					1.200"	4.500"	.250"	.250"	.700"	1/4-20 SHCS	6.000"
5775	15	Clear					1.450"	5.500"	.328"	.350"	.750"	1/4-20 SHCS	6.000"
5775-Black	15	Black					1.450"	5.500"	.328"	.350"	.750"	1/4-20 SHCS	6.000"
		H	J	K	L	M	N	P	Q	R	S	Weight	
5725	15	1.500"	.750"	3.560"	.750"	1.500"	.250"	1.250"	3.500"	1.004"	.328"	2.955 lb	
5725-Black	15	1.500"	.750"	3.560"	.750"	1.500"	.250"	1.250"	3.500"	1.004"	.328"	2.955 lb	
5775	15	1.500"	.750"	4.125"	.750"	1.500"	—	1.062"	3.875"	1.505"	.328"	4.100 lb	
5775-Black	15	1.500"	.750"	4.125"	.750"	1.500"	—	1.062"	3.875"	1.505"	.328"	4.100 lb	

* Or comparable

Suggested Hardware (Mount Stanchion to T-Slot)

Part No.	Bolt Assy.	Qty.	Bolt	T-Nut	Washer
5725	3423	8	5/16-18 x 1.75" SHCS	Economy	Yes
5775	3424	8	5/16-18 x 2" SHCS		

Stanchion Cross Clamp

Part Description:

The stanchion cross clamp is commonly used with the aluminum tube profile (page 827) to create two axes that are perpendicular to each other. The cross clamp is aluminum, making it a strong and durable option. Clamp screws are included.

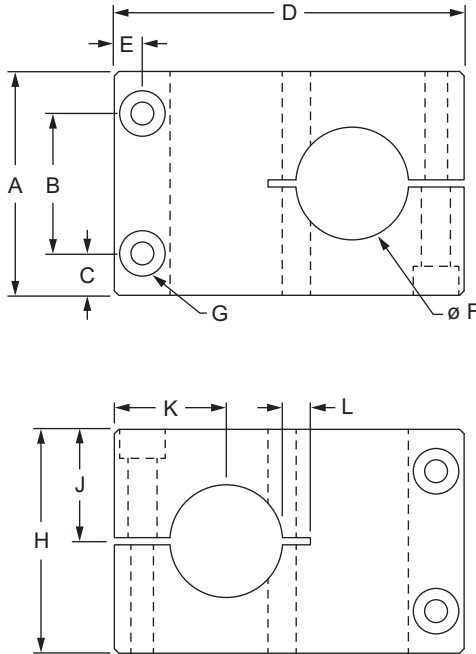

Part No.	Series	Color	Material	Alloy*	Finish	Process	A	B	C	D
5575	15	Clear	Aluminum	6105-T5	Anodize	Milled	2.000"	1.250"	.375"	3.125"
5575-Black	15	Black					2.000"	1.250"	.375"	3.125"
5625	15	Clear					2.500"	1.750"	.375"	4.125"
5625-Black	15	Black					2.500"	1.750"	.375"	4.125"
5675	15	Clear					3.250"	2.500"	.375"	5.500"
5675-Black	15	Black					3.250"	2.500"	.375"	5.500"
		E	F	G	H	J	K	L	Weight	
5575	15	.250"	1.004"	1/4-20 SHCS	2.000"	1.000"	1.000"	.250"	.937 lb	
5575-Black	15	.250"	1.004"	1/4-20 SHCS	2.000"	1.000"	1.000"	.250"	.937 lb	
5625	15	.328"	1.505"	1/4-20 SHCS	2.500"	1.250"	1.250"	-	1.669 lb	
5625-Black	15	.328"	1.505"	1/4-20 SHCS	2.500"	1.250"	1.250"		1.669 lb	
5675	15	.312"	2.005"	5/16-18 SHCS	3.250"	1.625"	1.625"		3.689 lb	
5675-Black	15	.312"	2.005"	5/16-18 SHCS	3.250"	1.625"	1.625"		3.689 lb	

* Or comparable

Part Description:

The single shaft stanchion mounting block is commonly used with the aluminum tube profile (page 827), for connecting additional profiles or accessories. There are several pre-drilled holes to accommodate both positioning and a wide range of products. The block is aluminum, making it strong and durable. Stanchion clamp screws are included.

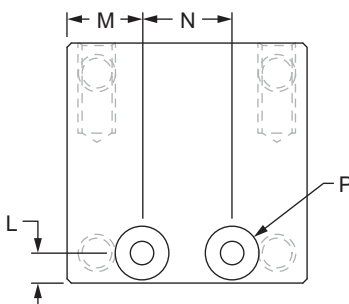
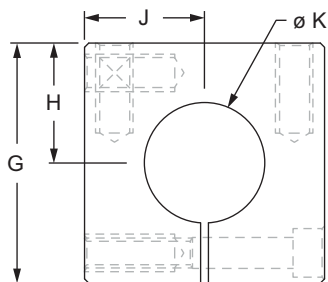
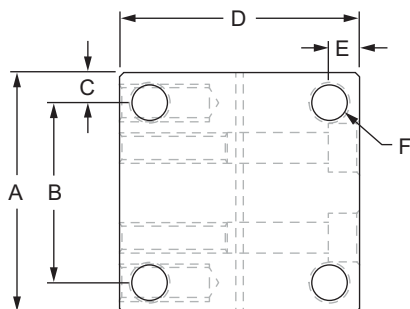

Part No.	Series	Color	Material	Alloy*	Finish	Process	A	B	C	D	E
5550	15	Clear	Aluminum	6105-T5	Anodize	Milled	2.000"	1.500"	.250"	2.000"	.250"
5550-Black	15	Black					2.000"	1.500"	.250"	2.000"	.250"
5600	15	Clear					2.500"	1.500"	.500"	2.500"	.500"
5600-Black	15	Black					2.500"	1.500"	.500"	2.500"	.500"
		F	G	H	J	K	L	M	N	P	Weight
5550	15	5/16-18	2.000"	1.000"	1.000"	1.004"	.250"	.625"	.750"	1/4-20 SHCS	.592 lb
5550-Black	15	5/16-18	2.000"	1.000"	1.000"	1.004"	.250"	.625"	.750"	1/4-20 SHCS	.592 lb
5600	15	5/16-18	2.500"	1.250"	1.250"	1.505"	.328"	.810"	.880"	1/4-20 SHCS	1.060 lb
5600-Black	15	5/16-18	2.500"	1.250"	1.250"	1.505"	.328"	.810"	.880"	1/4-20 SHCS	1.060 lb

* Or comparable

CONTINUE

Add-On Components

F
 Fractional

15
 15 Series

Single Shaft Stanchion Mounting Block (Continued)

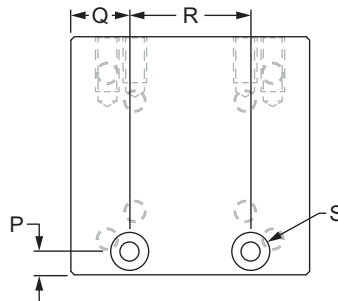
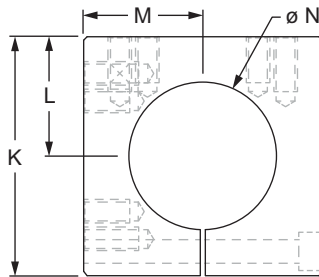
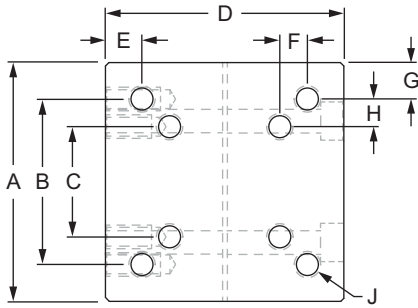

Part No.	Series	Color	Material	Alloy*	Finish	Process	A	B	C	D	E	F	G
5650	15	Clear	Aluminum	6105-T5	Anodize	Milled	3.250"	2.250"	1.500"	3.250"	.500"	.375"	.500"
5650-Black	15	Black					3.250"	2.250"	1.500"	3.250"	.500"	.375"	.500"
		H	J	K	L	M	N	P	Q	R	S	Weight	
5650	15	.375"	5/16-18	3.250"	1.625"	1.625"	2.005"	.328"	.800"	1.650"	5/16-18 SHCS	2.300 lb	
5650-Black	15	.375"	5/16-18	3.250"	1.625"	1.625"	2.005"	.328"	.800"	1.650"	5/16-18 SHCS	2.300 lb	

* Or comparable

Part Description:

The double shaft stanchion mounting block is commonly used with the aluminum tube profile (page 827) to create two additional axes. Tubes connect parallel to the mounted base to form the stanchions. The block is aluminum, making it a strong and durable option. Clamp screws are included. Suggested hardware to mount the base to a T-slot can be found below.

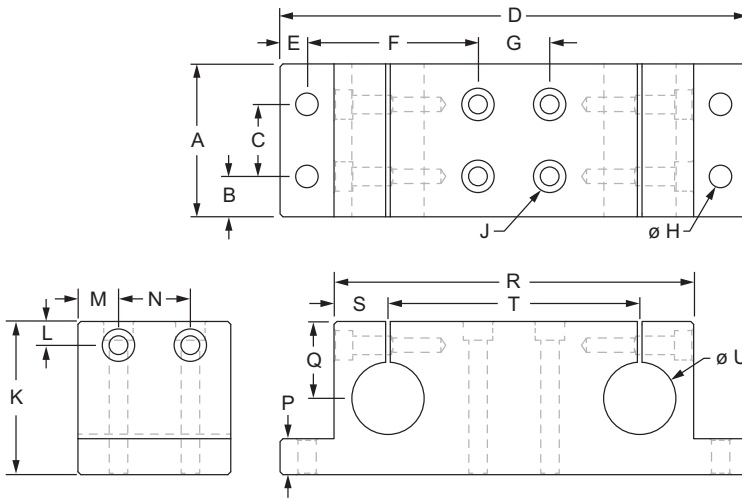

Part No.	Series	Color	Material	Alloy*	Finish	Process	A	B	C	D	E	F	G	H
5845	10	Clear	Aluminum	6105-T5	Anodize	Milled	2.125"	.563"	1.000"	6.500"	.375"	2.375"	1.000"	.257"
5845-Black	10	Black					2.125"	.563"	1.000"	6.500"	.375"	2.375"	1.000"	.257"
5850	15	Clear					2.125"	.312"	1.500"	6.500"	.375"	2.125"	1.500"	.328"
5850-Black	15	Black					2.125"	.312"	1.500"	6.500"	.375"	2.125"	1.500"	.328"
5900	15	Clear					2.500"	.500"	1.500"	7.750"	.375"	2.750"	1.500"	.328"
5900-Black	15	Black					2.500"	.500"	1.500"	7.750"	.375"	2.750"	1.500"	.328"
5950	15	Clear					3.250"	.875"	1.500"	9.500"	.500"	3.500"	1.500"	.328"
5950-Black	15	Black					3.250"	.875"	1.500"	9.500"	.500"	3.500"	1.500"	.328"
		J	K	L	M	N	P	Q	R	S	T	U	Weight	
5845	10	1/4-20 SHCS	2.130"	.330"	.563"	1.000"	.500"	1.068"	5.000"	.750"	3.500"	1.004"	1.861 lb	
5845-Black	10	1/4-20 SHCS	2.130"	.330"	.563"	1.000"	.500"	1.068"	5.000"	.750"	3.500"	1.004"	1.861 lb	
5850	15	5/16-18 SHCS	2.130"	.330"	.560"	1.000"	.500"	1.068"	5.000"	.750"	3.500"	1.004"	1.857 lb	
5850-Black	15	5/16-18 SHCS	2.130"	.330"	.560"	1.000"	.500"	1.068"	5.000"	.750"	3.500"	1.004"	1.857 lb	
5900	15	5/16-18 SHCS	2.500"	.325"	.500"	1.500"	.750"	1.125"	6.130"	1.128"	3.875"	1.505"	3.857 lb	
5900-Black	15	5/16-18 SHCS	2.500"	.325"	.500"	1.500"	.750"	1.125"	6.130"	1.128"	3.875"	1.505"	3.061 lb	
5950	15	5/16-18 SHCS	3.250"	.320"	.875"	1.500"	1.000"	1.625"	7.500"	1.375"	4.750"	2.005"	6.061 lb	
5950-Black	15	5/16-18 SHCS	3.250"	.320"	.875"	1.500"	1.000"	1.625"	7.500"	1.375"	4.750"	2.005"	6.220 lb	

* Or comparable

Suggested Hardware (Mount Stanchion to T-Slot)

Part No.	Bolt Assy.	Qty.	Bolt	T-Nut	Washer	AND / OR	Bolt Assy.	Qty.	Bolt	T-Nut	Washer	
5845	3471	4	1/4-20 x 7/8" SHCS	Economy	Yes			3433	4	1/4-20 x 2.125" SHCS	Economy	No
5850	3470	4	5/16-18 x 1" SHCS					3427	4	5/16-18 x 2.25" SHCS		
5900	3421	4	5/16-18 x 1.25" SHCS					3429	4	5/16-18 x 2.5" SHCS		
5950	3422	4	5/16-18 x 1.5" SHCS			3431		4	5/16-18 x 3.25" SHCS			

Narrow Horizontal Stanchion Base

Part Description:

The narrow horizontal stanchion base is commonly used with the aluminum tube profile (page 827) to create an additional axis. The tube extends parallel from both sides of the mounted base. The base is aluminum, making it a strong and durable option. Clamp screws are included while the suggested hardware to mount the base to a T-slot can be found below.

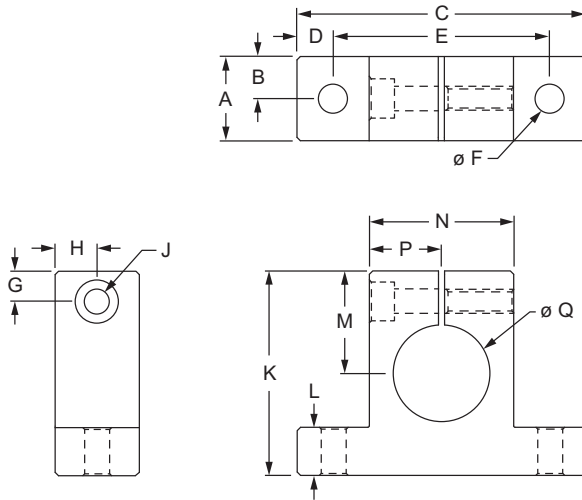

Part No.	Series	Color	Material	Alloy*	Finish	Process	A	B	C	D	E	F
5860	10	Clear	Aluminum	6105-T5	Anodize	Milled	.875"	.438"	3.000"	.375"	2.250"	.257"
5860-Black	10	Black					.875"	.438"	3.000"	.375"	2.250"	.257"
5870	15	Clear					.875"	.438"	3.000"	.375"	2.250"	.328"
5870-Black	15	Black					.875"	.438"	3.000"	.375"	2.250"	.328"
5880	15	Clear					1.125"	.560"	3.875"	.437"	3.000"	.328"
5880-Black	15	Black					1.125"	.560"	3.875"	.437"	3.000"	.328"
5890	15	Clear					1.437"	.718"	4.750"	.500"	3.750"	.328"
5890-Black	15	Black					1.437"	.718"	4.750"	.500"	3.750"	.328"
		G	H	J	K	L	M	N	P	Q	Weight	
5860	10	.313"	.438"	1/4-20 SHCS	2.125"	.500"	1.062"	1.500"	.750"	1.004"	.264 lb	
5860-Black	10	.313"	.438"	1/4-20 SHCS	2.125"	.500"	1.062"	1.500"	.750"	1.004"	.264 lb	
5870	15	.313"	.438"	1/4-20 SHCS	2.125"	.500"	1.062"	1.500"	.750"	1.004"	.262 lb	
5870-Black	15	.313"	.438"	1/4-20 SHCS	2.125"	.500"	1.062"	1.500"	.750"	1.004"	.262 lb	
5880	15	.313"	.560"	1/4-20 SHCS	2.500"	.750"	1.125"	2.253"	1.127"	1.505"	.547 lb	
5880-Black	15	.313"	.560"	1/4-20 SHCS	2.500"	.750"	1.125"	2.253"	1.127"	1.505"	.547 lb	
5890	15	.313"	.718"	5/16-18 SHCS	3.250"	1.000"	1.625"	2.750"	1.375"	2.005"	1.080 lb	
5890-Black	15	.313"	.718"	5/16-18 SHCS	3.250"	1.000"	1.625"	2.750"	1.375"	2.005"	1.080 lb	

* Or comparable

Suggested Hardware (Mount Stanchion to T-Slot)

Part No.	Bolt Assy.	Qty.	Bolt	T-Nut	Washer
5860	3471	2	1/4-20 x 7/8" SHCS	Economy	Yes
5870	3470	2	5/16-18 x 1" SHCS		
5880	3421	2	5/16-18 x 1.25" SHCS		
5890	3422	2	5/16-18 x 1.5" SHCS		

Part Description:

The wide horizontal stanchion base is commonly used with the aluminum tube profile (page 827) to create an additional axis. The tube extends parallel from both sides of the mounted base. It is a wider option, making it sturdy and durable. Clamp screws are included while the suggested hardware to mount the base to a T-slot can be found below.

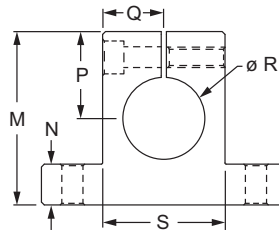
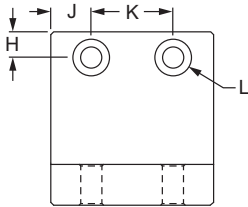
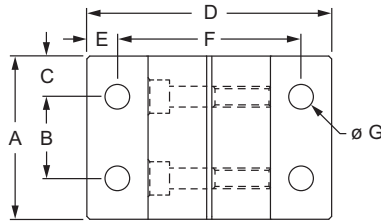

Part No.	Series	Color	Material	Alloy*	Finish	Process	A	B	C	D	E	F	G
5910	10	Clear	Aluminum	6105-T5	Anodize	Milled	2.000"	1.000"	.500"	3.000"	.375"	2.250"	.257"
5910-Black	10	Black					2.000"	1.000"	.500"	3.000"	.375"	2.250"	.257"
5920	15	Clear					2.000"	1.500"	.250"	3.000"	.375"	2.250"	.328"
5920-Black	15	Black					2.000"	1.500"	.250"	3.000"	.375"	2.250"	.328"
5930	15	Clear					2.500"	1.500"	.500"	3.875"	.438"	3.000"	.328"
5930-Black	15	Black					2.500"	1.500"	.500"	3.875"	.438"	3.000"	.328"
5940	15	Clear					3.250"	1.500"	.875"	4.750"	.500"	3.750"	.328"
5940-Black	15	Black					3.250"	1.500"	.875"	4.750"	.500"	3.750"	.328"
		H	J	K	L	M	N	P	Q	R	S	Weight	
5910	10	.313"	.500"	1.000"	1/4-20 SHCS	2.125"	.500"	1.063"	.750"	1.004"	1.500"	.604 lb	
5910-Black	10	.313"	.500"	1.000"	1/4-20 SHCS	2.125"	.500"	1.063"	.750"	1.004"	1.500"	.604 lb	
5920	15	.313"	.500"	1.000"	1/4-20 SHCS	2.125"	.500"	1.063"	.750"	1.004"	1.500"	.596 lb	
5920-Black	15	.313"	.500"	1.000"	1/4-20 SHCS	2.125"	.500"	1.063"	.750"	1.004"	1.500"	.596 lb	
5930	15	.313"	.500"	1.500"	1/4-20 SHCS	2.500"	.750"	1.375"	1.128"	1.505"	2.255"	1.222 lb	
5930-Black	15	.313"	.500"	1.500"	1/4-20 SHCS	2.500"	.750"	1.375"	1.128"	1.505"	2.255"	1.222 lb	
5940	15	.313"	.875"	1.500"	5/16-18 SHCS	3.250"	1.000"	1.625"	1.375"	2.005"	2.750"	2.470 lb	
5940-Black	15	.313"	.875"	1.500"	5/16-18 SHCS	3.250"	1.000"	1.625"	1.375"	2.005"	2.750"	2.470 lb	

* Or comparable

Suggested Hardware (Mount Stanchion to T-Slot)

Part No.	Bolt Assy.	Qty.	Bolt	T-Nut	Washer
5910	3471	4	1/4-20 x 7/8" SHCS	Economy	Yes
5920	3470	4	5/16-18 x 1" SHCS		
5930	3421	4	5/16-18 x 1.25" SHCS		
5940	3422	4	5/16-18 x 1.5" SHCS		

Horizontal Stanchion Quick Clamp

Part Description:

The horizontal stanchion quick clamp is commonly used with the aluminum tube profile (page 827) to create an additional axis. The tube extends parallel from both sides of the mounted base. The clamp includes a black nylon ratcheting handle (page 780) that enables easy positioning and repositioning.

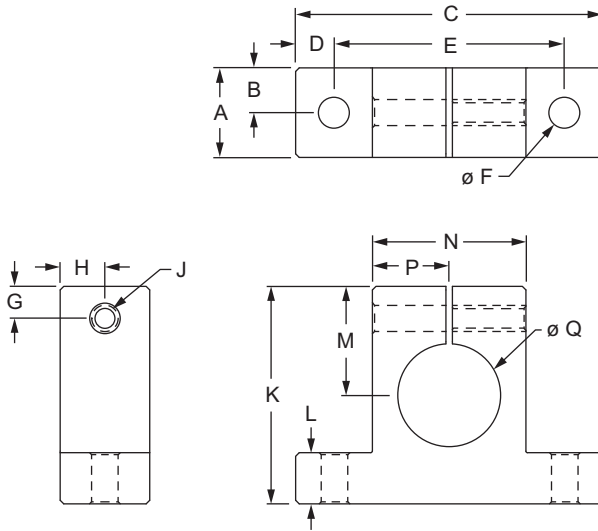

Part No.	Series	Color	Material	Alloy*	Finish	Process	A	B	C	D	E	F
5360	10	Clear	Aluminum	6105-T5	Anodize	Milled	.875"	.438"	3.000"	.375"	2.250"	.257"
5360-Black	10	Black					.875"	.438"	3.000"	.375"	2.250"	.257"
5370	15	Clear					.875"	.438"	3.000"	.375"	2.250"	.328"
5370-Black	15	Black					.875"	.438"	3.000"	.375"	2.250"	.328"
		G	H	J	K	L	M	N	P	Q	Weight	
5360	10	.313"	.438"	1/4-20	2.125"	.500"	1.062"	1.500"	.750"	1.004"	.304 lb	
5360-Black	10	.313"	.438"	1/4-20	2.125"	.500"	1.062"	1.500"	.750"	1.004"	.304 lb	
5370	15	.313"	.438"	1/4-20	2.125"	.500"	1.062"	1.500"	.750"	1.004"	.299 lb	
5370-Black	15	.313"	.438"	1/4-20	2.125"	.500"	1.062"	1.500"	.750"	1.004"	.299 lb	

* Or comparable

Suggested Hardware (Mount Stanchion to T-Slot)

Part No.	Bolt Assy.	Qty.	Bolt	T-Nut	Washer
5360	3471	2	1/4-20 x 7/8" SHCS	Economy	Yes
5370	3470	2	5/16-18 x 1" SHCS		

Part Description:

The quick stanchion cross clamp is commonly used with the aluminum tube profile (page 827) to create two custom axes that are perpendicular to each other. It includes two black nylon ratcheting handles (page 780) that enable easy positioning and repositioning. The stanchion cross clamp is aluminum, making it a strong and durable option.

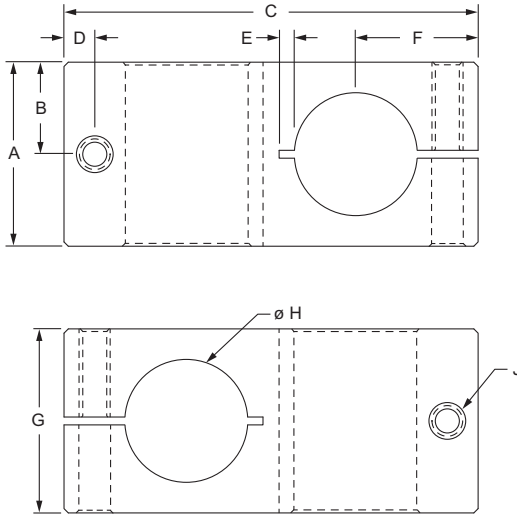

Part No.	Series	Color	Material	Alloy*	Finish	Process	A	B	C	D	E	F	G	H	J	Weight
5340	F	Clear	Aluminum	6105-T5	Anodize	Milled	1.500"	.750"	3.375"	.250"	.125"	1.000"	1.500"	1.004"	1/4-20	.577 lb
5340-Black	F	Black					1.500"	.750"	3.375"	.250"	.125"	1.000"	1.500"	1.004"	1/4-20	.577 lb

* Or comparable

Stanchion Clamp Handle

Part Description:

The stanchion clamp handle is ratcheting, made of black nylon and is commonly used with a clamp to enable easy positioning and repositioning of a stanchion.

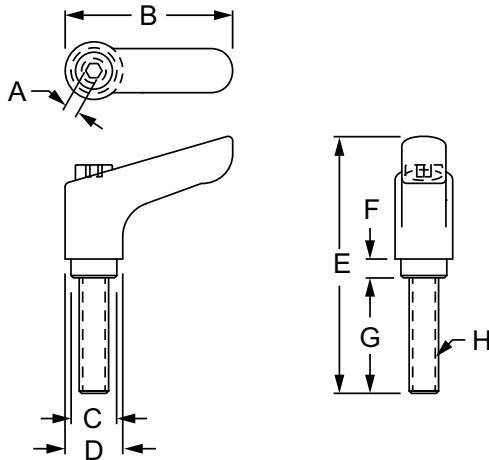

Part No.	Series	Material	Grade	Color	A	B	C	D	E	F	G	H	Weight
6847	F	Plastic	Nylon	Black	.120"	1.425"	.390"	.490"	2.463"	.160"	1.260"	1/4-20	.047 lb

Pictorial Table Of Contents



Finishing Touches



Page 783

Protection Options



Page 783

Wire & Cable Management

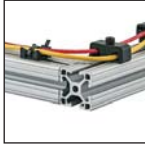

Page 784

Storage & Organization



Page 784

Accessories

End Cap with Push-In Fastener



Page 785

Push-In Fastener



Page 785

Self Tapping End Cap Screw



Page 786

End Cap with Molded Push-In Stem



Page 787

Screw-On End Cap



Page 788

3 Way - Corner Bracket Cover Cap



Page 789

Ready Tube End Cap



Page 790

Quick Frame End Cap



Page 790

Aluminum T-Slot Cover



Page 791

Standard T-Slot Cover



Page 792

Economy T-Slot Cover



Page 793

Reduction T-Slot Cover



Page 794

Rubber T-Slot Cover



Page 795

Tread Strip



Page 796

Wiring Duct



Page 797

Cable Tie

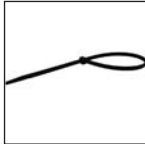

Page 798

Cable Tie Mounting Pad



Page 799

Drop-In Cable & Tube Clip



Page 801

Cable & Tube Clip



Page 802

Cable Tie Mounting Block



Page 803

Single Cable & Tube Clamp



Page 804

Double Cable & Tube Clamp



Page 805

Wiremold[®] Power Strip



Page 806

Anodize Breaker



Page 807

Grounding Terminal



Page 808

Storage Bin



Page 809

Storage Bin Hanger



Page 810

Adjustable Monitor Mount



Page 811

CONTINUE



Pictorial Table Of Contents

Slide-In
Tool Hanger



Page 812

Tool Hanger
Spring Hook



Page 813

Tool Holder -
Open Bottom



Page 814

Cup Holder -
Closed Bottom



Page 815

Light-Duty
Adhesive Clamp



Page 816

Label Holder



Page 817

Rubber Bumper



Page 818



Finishing Touches

80/20 accessories pull together your project and give it the finishing touches to make it fit your exact specifications. There are a wide variety of options; from storage and organization to wire and tube management, you'll find what you need to enhance and personalize your project.

When adding accessories, it's helpful to consider a few overall categories:

- Protection
- Wire & Cable Management
- Storage and Organization



Keep in Mind

Some products can be used in multiple categories. For instance, T-slot covers provide protection from debris buildup and can also be used to manage wires and cables recessed within the T-slot.

Protection

Accessories in this category are used for a range of purposes from protecting people and equipment from sharp edges and damage to keeping dust out of T-slots. Some of the products, such as T-slot covers and end caps, also add a finishing look to your project.

- End caps
- T-slot covers
- Tread strip
- Anodize breaker
- Grounding terminal
- Rubber bumper



Tip: Try aluminum T-slot covers to blend in with your profile or use colors to stand out and denote caution or warning.

Wire and Cable Management

Wire and cable management products improve safety by keeping your application clean, protected and organized. These products decrease the possibility of damage to wires, cables and tubes and can be quickly and easily installed into any project. The variety of options available provides flexibility in design and implementation.

- Wiring duct
- Cable tie mounting pad
- Cable and tube clip
- Cable tie mounting block
- Single and double tube clamps



Tip: Wiring duct has interlocking ends so you can make the duct any customized length.

Storage and Organization

Storage and organization accessories come in a range of colors and sizes to accommodate your processes. Keep clutter at bay and streamline operations by incorporating these products into your application.

- Storage bins
- Slide-in tool hanger
- Tool hanger spring hook
- Light-duty adhesive clamp
- Label holder

Important Note: Storage bins are mounted to a T-slot profile using storage bin hangers (see page 810).

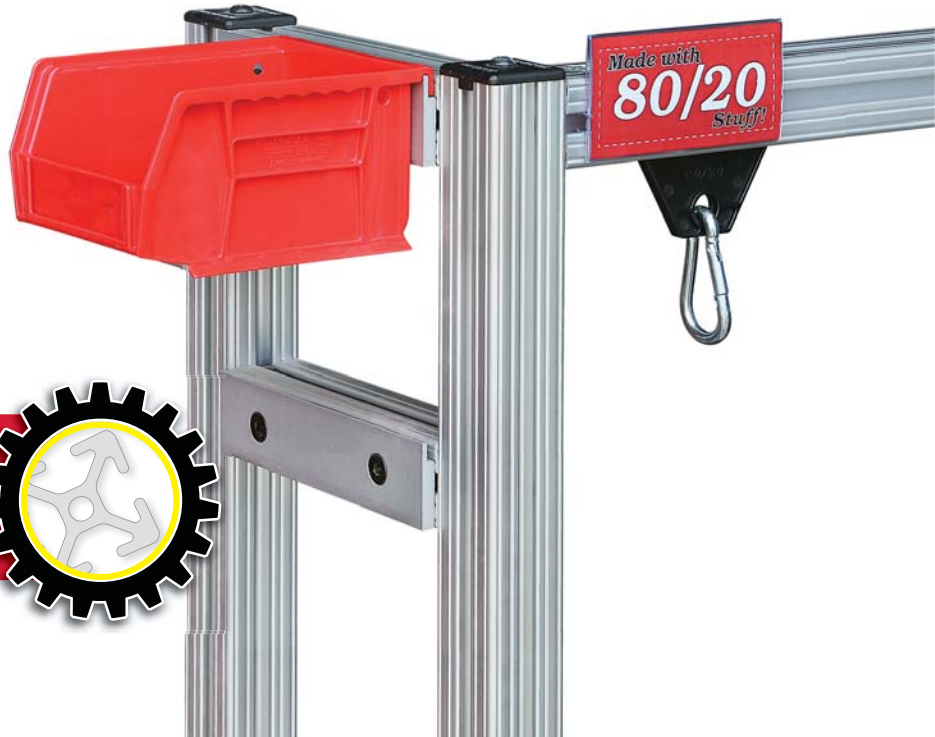

That's Not All

Be sure to browse through all of the products to find everything you need to finish your project.

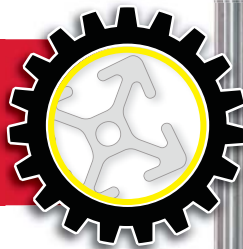

Part Description:

The end cap with push-in fastener adds a finishing touch to your project and closes off profile ends to limit dust and debris buildup. It can be installed with a push-in fastener, self-tapping screw (page 786) or into a tapped hole using a button head socket cap screw. Choose from black, red, blue, yellow or gray to color-coordinate with your application. The black end cap is available with or without the 80/20 logo, while the colored caps include the logo.

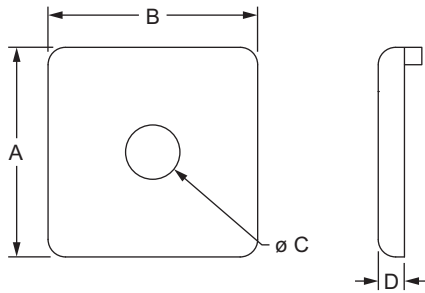

80/20 Black Cap	Red Cap	Blue Cap	Yellow Cap	Gray Cap	Black Cap	Series	A	B	C	D	Weight
2015	2015RED	2015BLU	2015YEL	2015GRA	2015-Plain	10	1.000"	1.000"	.257"	.125"	.008 lb
2025	2025RED	2025BLU	2025YEL	2025GRA	2025-Plain	10	1.000"	2.000"	.257"	.125"	.009 lb
2026	2026RED	2026BLU	2026YEL	2026GRA	2026-Plain	10	1.000"	3.000"	.257"	.125"	.013 lb
2028	2028RED	2028BLU	2028YEL	2028GRA	2028-Plain	10	2.000"	2.000"	.257"	.125"	.017 lb
2030	2030RED	2030BLU	2030YEL	2030GRA	2030-Plain	15	1.500"	1.500"	.328"	.188"	.013 lb
2045	2045RED	2045BLU	2045YEL	2045GRA	2045-Plain	15	1.500"	3.000"	.328"	.188"	.031 lb
2046	2046RED	2046BLU	2046YEL	2046GRA	2046-Plain	15	1.500"	4.500"	.328"	.188"	.049 lb
2050	2050RED	2050BLU	2050YEL	2050GRA	2050-Plain	15	3.000"	3.000"	.328"	.188"	.064 lb

80/20 Black Cap	Black Cap	Series	Material	Finish	Process	A	B	C	D	Weight
25-2015	25-2015-Plain	25	ABS	Matte	Molded	25.00mm	25.00mm	6.80mm	3.00mm	.0044 kg
25-2025	25-2025-Plain	25				25.00mm	50.00mm	6.80mm	3.00mm	.0068 kg
25-2028	25-2028-Plain	25				50.00mm	50.00mm	6.80mm	3.00mm	.0034 kg
40-2030	40-2030-Plain	40				40.00mm	40.00mm	8.40mm	4.50mm	.0068 kg
40-2045	40-2045-Plain	40				40.00mm	80.00mm	8.50mm	4.50mm	.0132 kg
40-2050	40-2050-Plain	40				80.00mm	80.00mm	8.50mm	4.50mm	.0282 kg

Push-In Fastener

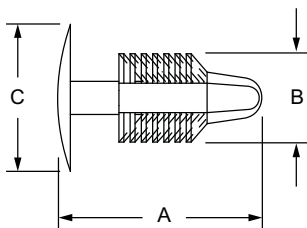

3272, 25-3272



3274, 40-3274

Black Cap	Red Cap	Blue Cap	Yellow Cap	Gray Cap	Series	Material	A	B	C	Weight
3272	3272RED	3272BLU	3272YEL	3272GRA	10	Plastic	.555"	.240"	.400"	.0004 lb
3274	3274RED	3274BLU	3274YEL	3274GRA	15		.643"	.300"	.700"	.0010 lb
25-3272	—	—	—	—	25		14.10mm	6.10mm	10.16mm	.0002 kg
40-3274	—	—	—	—	40		16.33mm	7.62mm	17.88mm	.0006 kg

Finishing Your Frame

F Fractional **10** 10 Series **15** 15 Series **M** Metric **25** 25 Series **40** 40 Series

End Cap with Push-In Fastener / Self Tapping End Cap Screw

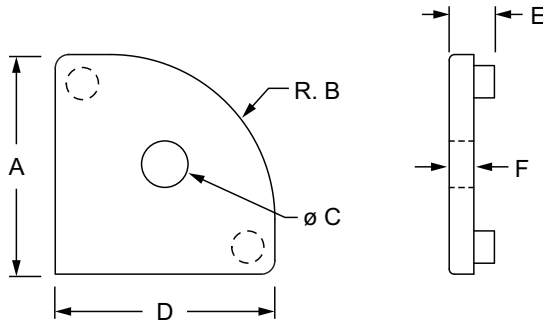

80/20 Black Cap	Red Cap	Blue Cap	Yellow Cap	Gray Cap	Black Cap	Series	A	B	C	D	E	F	Weight
2022	2022RED	2022BLU	2022YEL	2022GRA	2022-Plain	10	1.000"	.727"	.257"	1.000"	.213"	.125"	.004 lb
2035	2035RED	2035BLU	2035YEL	2035GRA	2035-Plain	15	1.500"	1.125"	.328"	1.500"	.283"	.188"	.016 lb
40-2033	—	—	—	—	—	40	40.00mm	30.00mm	8.45mm	40.00mm	8.25mm	4.50mm	.0073 kg

Material Specifications

Material	Finish	Process
ABS	Matte	Molded

Self Tapping End Cap Screw (STECs)

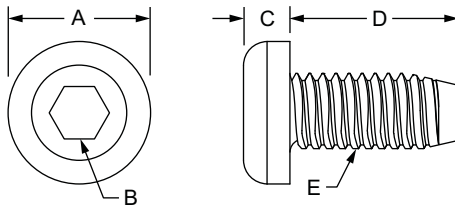

Black Zinc

Bright Zinc



Part No.	Series	Material	Finish	A	B	C	D (Length)	E (Thread)	Weight
3766	10	Steel	Bright Zinc	.428"	.157"	.127"	.360"	12-24	.005 lb
3266	10		Black Zinc	.428"	.157"	.127"	.360"	12-24	.005 lb
3767	15		Bright Zinc	.428"	.157"	.127"	.360"	M7 x 1.0	.008 lb
3267	15		Black Zinc	.428"	.157"	.127"	.360"	M7 x 1.0	.008 lb
25-3766	25		Bright Zinc	10.90mm	4.00mm	3.23mm	9.12mm	12-24	.0025 kg
25-3266	25		Black Zinc	10.90mm	4.00mm	3.23mm	9.12mm	12-24	.0025 kg
40-3767	40		Bright Zinc	10.90mm	4.00mm	3.23mm	9.14mm	M7 x 1.0	.0037 kg
40-3267	40		Black Zinc	10.90mm	4.00mm	3.23mm	9.14mm	M7 x 1.0	.0037 kg

Part Description:

The end cap with molded push-in stem adds a finishing touch to your project and closes off profile ends to limit dust and debris buildup. It comes in black with molded push-in stems for easy installation.

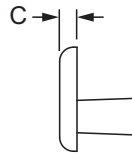
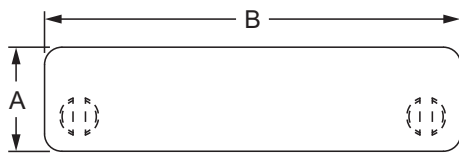

80/20 Black Cap	Plain Black Cap	Series	Color	Material	Finish	Process	A	B	C	Weight
2036	—	15	Black	ABS	Matte	Molded	.750"	1.500"	.125"	.006 lb
2037	—	15					.750"	3.000"	.125"	.010 lb
—	12305	20					20.00mm	20.00mm	2.50mm	.0009 kg
—	12306	20					20.00mm	40.00mm	2.50mm	.0021 kg
—	12307	20					40.00mm	40.00mm	2.50mm	.0041 kg
—	12271	30					30.00mm	30.00mm	4.00mm	.0038 kg
—	12302	30					30.00mm	60.00mm	4.00mm	.0034 kg
—	12303	30					60.00mm	60.00mm	4.00mm	.0154 kg
40-2035	40-2035-Plain	40					40.00mm	40.00mm	4.50mm	.0054 kg
—	12258	40					40.00mm	40.00mm	4.00mm	.0054 kg
—	12260	40					40.00mm	40.00mm	4.00mm	.0068 kg
—	12261	40					40.00mm	80.00mm	4.00mm	.0136 kg
—	12290	40					40.00mm	120.00mm	4.00mm	.0218 kg
—	12298	40					80.00mm	160.00mm	4.00mm	.0619 kg
—	12262	45					45.00mm	45.00mm	4.00mm	.0082 kg
—	12259	45					45.00mm	90.00mm	4.00mm	.0200 kg
—	12269	45					90.00mm	90.00mm	4.00mm	.0448 kg

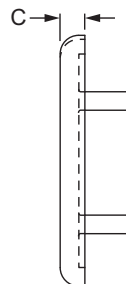
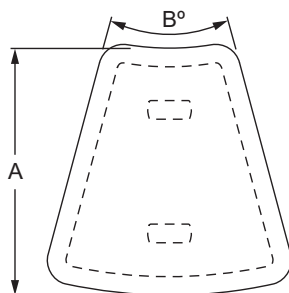

Black Cap	Series	Color	Material	Grade	Finish	Process	A	B	C	Weight
40-2037	40	Black	Nylon	PA6 GF30	Matte	Molded	40.00mm	30°	4.00mm	.0057 kg
40-2039	40						40.00mm	45°	4.00mm	.0084 kg
40-2043	40						40.00mm	60°	4.00mm	.0104 kg

Screw-On End Cap

Part Description:

The screw-on end cap includes a flat head socket cap screw that spreads the pin to secure the end cap and does not require a profile end tap. It adds a finishing touch to your project and closes off profile ends to limit dust and debris buildup.

FINISH YOUR FRAME

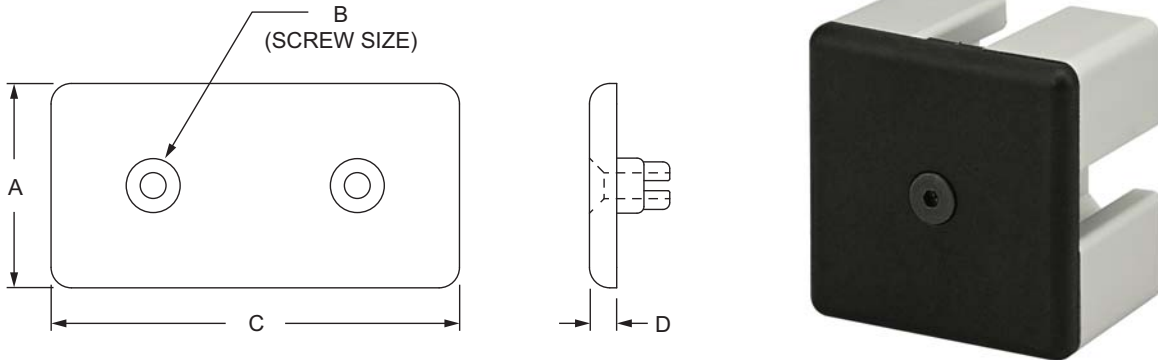

Black Cap	Series	A	B	C	D	Weight
12279	30	30.00mm	M4 FHSCS	60.00mm	4.00mm	.0073 kg
12283	45	45.00mm	M4 FHSCS	45.00mm	4.00mm	.0088 kg
12286	45	45.00mm	M4 FHSCS	90.00mm	4.00mm	.0174 kg
12287	45	90.00mm	M4 FHSCS	90.00mm	4.00mm	.0345 kg

Material Specifications

Material	Grade	Finish	Process
Nylon	PA6 GF30	Matte	Molded

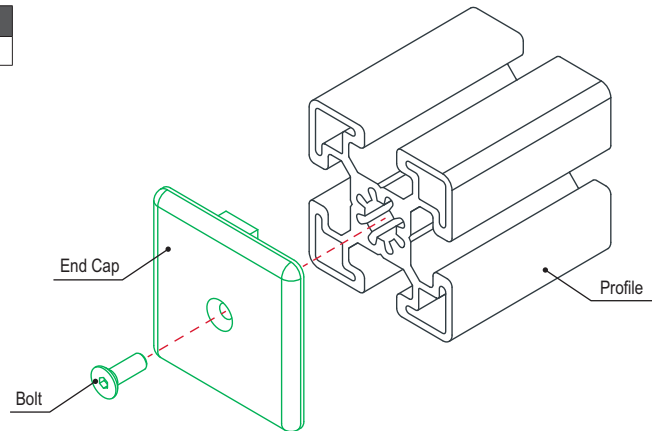

Part Description:

The 3 way – corner bracket cover cap is made of black nylon and used with the 3 way – triangular corner bracket (page 317) and the 3 way – rounded corner bracket (page 318) to add a layer of protection and an aesthetic appearance.

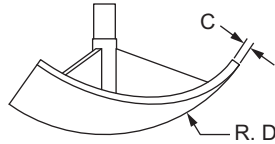
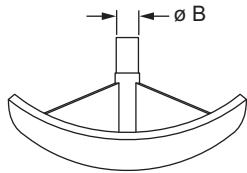
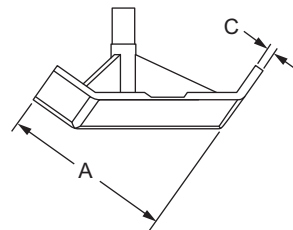
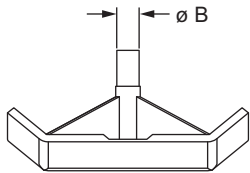
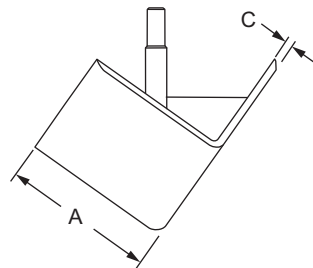
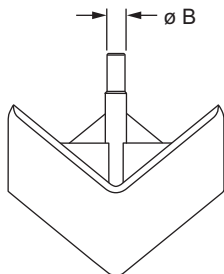
**12043****12044, 12047****12041, 12045**

Black Cap	Series	Material	Color	Connector	Profile	A	B	C	D	Weight
12043	15	Nylon	Black	14113	1517-LS, 1517	—	.197"	.079"	28.6°	.021 lb
12044	15			14113	1547	1.490"	.197"	.079"	—	.030 lb
12041	30			14112	30-3030	30.00mm	4.20mm	2.00mm	—	.0086 kg
12047	40			14114	40-4045-Lite	40.00mm	5.00mm	2.00mm	—	.0077 kg
12045	40			14114	40mm X 40mm Profiles	40.00mm	5.00mm	2.00mm	—	.0154 kg

Ready Tube End Cap

The Ready Tube™ end cap adds a finishing touch to your project and closes off profile ends to limit dust and debris buildup. It has a molded push-in stem for easy installation.

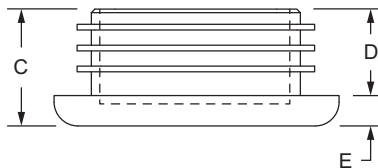
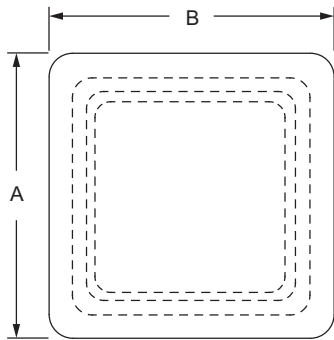

80/20 Black Cap	Black Cap	Series	Material	Grade	Process	A	B	C	D	E	Weight
9755	9755-Plain	RT	Plastic	Nylon	Injection Molded	1.500"	1.500"	.615"	.455"	.160"	.015 lb

Quick Frame End Cap

The Quick Frame™ end cap adds a finishing touch to your project and closes off profile ends to limit dust and debris buildup. It is available in black or gray and pushes into Quick Frame profiles for easy installation.

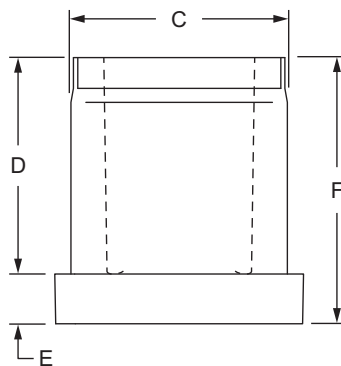
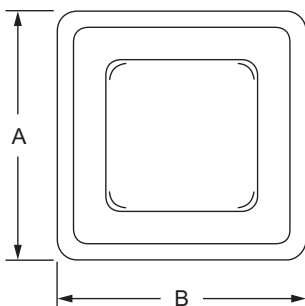

Part No.	Series	Material	Grade	Process	Color	A	B	C	D	E	F	Weight
9110	QF	Plastic	Nylon	Injection Molded	Gray	1.000"	1.000"	.850"	.870"	.200"	1.070"	.020 lb
9210	QF				Black	1.000"	1.000"	.850"	.870"	.200"	1.070"	.020 lb

Part Description:

The aluminum T-slot cover is available in black or clear anodize for 15 and 40-series profiles. It prevents dust and debris build up, covers wires and tubes in the T-slot channel, and adds a great finishing touch that blends into projects for a polished look.

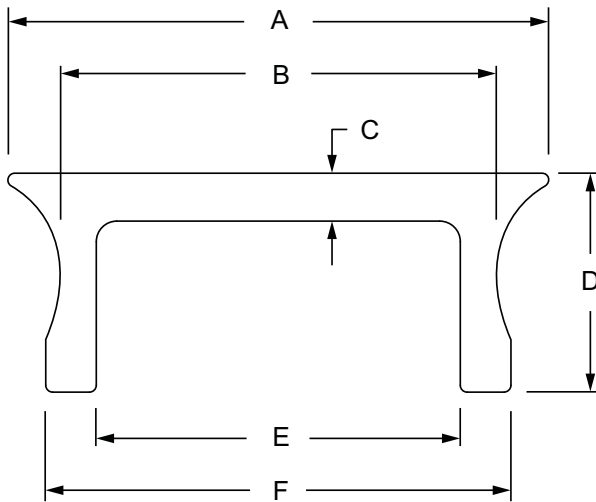

Part No.	Series	Color	A	B	C	D	E	F	Stock Length	Weight
2119	15	Clear	.395"	.319"	.035"	.160"	.266"	.340"	72.500"	.002 lb / in.
2119-Black	15	Black	.395"	.319"	.035"	.160"	.266"	.340"		.002 lb / in.
40-2119	40	Clear	10.02mm	8.11mm	.89mm	4.06mm	6.76mm	8.64mm	1841.50mm	.06758 kg / mm
40-2119-Black	40	Black	10.02mm	8.11mm	.89mm	4.06mm	6.76mm	8.64mm		.06758 kg / mm

Material Specifications

Material	Alloy*	Finish	Process
Aluminum	6105-T5	Anodize	Extruded

* Or comparable

Required Machining Services

Machining Type	Part Machined	Reference Page
Cut to Length	T-slot Cover	852

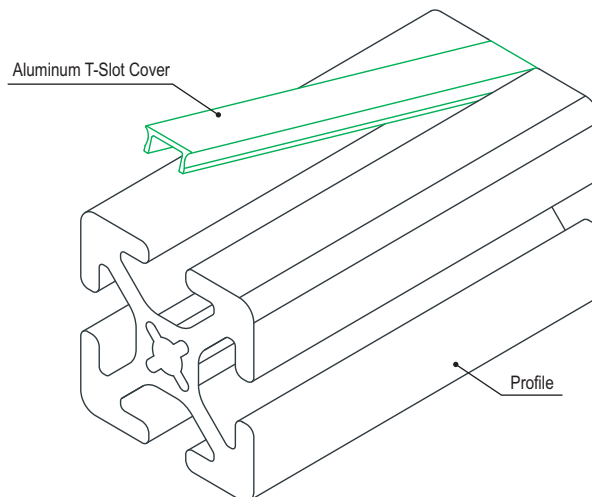

Standard T-Slot Cover

Part Description:

The standard T-slot cover is more rigid for heavy use applications. It adds a finishing touch and polished look to an application. It prevents dust and debris build up and covers wires and tubes in the T-slot channel. There are options available in black, gray, or safety yellow. **Tip:** Use a soft faced mallet (page 906) to tap the cover into the T-slot.

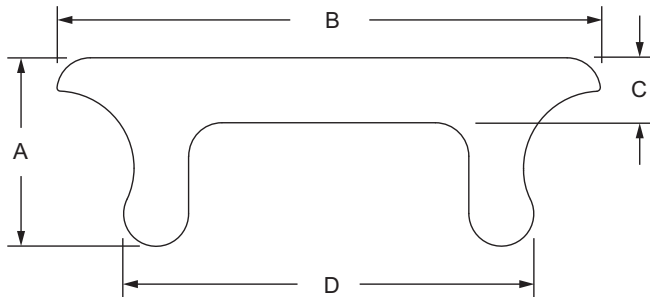

Part No.	Series	Color	Material	Finish	Process	A	B	C	D	Stock Length	Weight
2112	10	Yellow	PVC	Matte	Extruded	.102"	.338"	.035"	.266"	72.500"	.059 lb
2113	10	Black				.102"	.338"	.035"	.266"		.059 lb
2114	10	Gray				.102"	.338"	.035"	.266"		.059 lb
2109	15	Yellow	Polypropylene			.222"	.484"	.060"	.350"		.099 lb
2110	15	Black				.222"	.484"	.060"	.350"		.111 lb
2111	15	Gray				.222"	.484"	.060"	.350"		.106 lb
25-2112	25	Yellow	PVC			2.59mm	8.59mm	.89mm	6.76mm	1841.50mm	.0268 kg
25-2113	25	Black				2.59mm	8.59mm	.89mm	6.76mm		.0245 kg
25-2114	25	Gray				2.59mm	8.59mm	.89mm	6.76mm		.0268 kg
40-2109	40	Yellow	Polypropylene			5.64mm	12.29mm	1.52mm	8.89mm		.0481 kg
40-2110	40	Black				5.64mm	12.29mm	1.52mm	8.89mm		.0490 kg
40-2111	40	Gray				5.64mm	12.29mm	1.52mm	8.89mm		.0485 kg

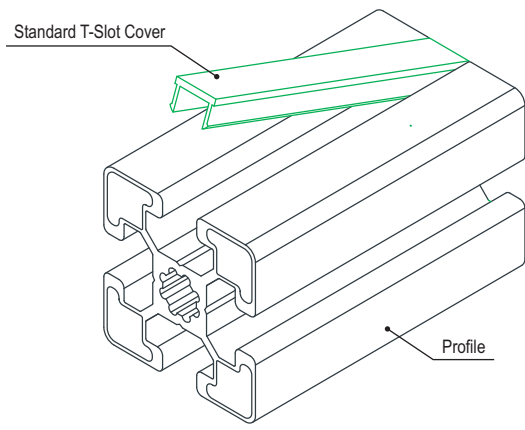

Part Description:

The economy T-slot cover is a cost-effective way to add a finishing touch and polished look to an application. It prevents dust and debris build up and covers wires and tubes in the T-slot channel. There are options available in black, gray, red, blue, orange, or safety yellow. **Tip:** Use a soft faced mallet (page 906) to tap the cover into the T-slot.

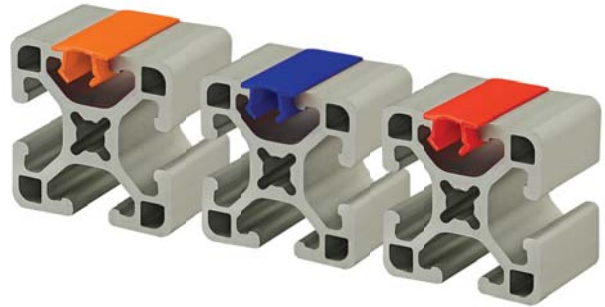
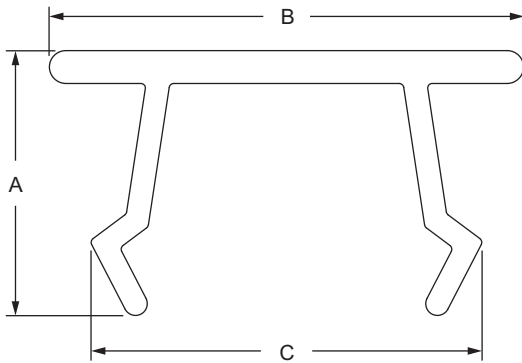

Part No.	Series	Color	Material	Finish	Process	A	B	C	Stock Length	Weight			
2819	10	Yellow	PVC	Matte	Extruded	.211"	.430"	.313"	72.500"	.080 lb			
2820	10	Black				.211"	.430"	.313"		.083 lb			
2821	10	Gray				.211"	.430"	.313"		.076 lb			
2818	10	Red				.211"	.430"	.313"		.098 lb			
2817	10	Blue				.211"	.430"	.313"		.080 lb			
2816	10	Orange				.211"	.430"	.313"		.091 lb			
2822	15	Yellow				.282"	.505"	.416"	.131 lb				
2823	15	Black				.282"	.505"	.416"	.133 lb				
2824	15	Gray				.282"	.505"	.416"	.126 lb				
2825	15	Red				.282"	.505"	.416"	.124 lb				
2826	15	Blue				.282"	.505"	.416"	.126 lb				
2827	15	Orange				.282"	.505"	.416"	.127 lb				
25-2819	25	Yellow				Polypropylene	Matte	Extruded	5.36mm	10.92mm	7.95mm	1841.50mm	.0354 kg
25-2820	25	Black							5.36mm	10.92mm	7.95mm		.0363 kg
25-2821	25	Gray							5.36mm	10.92mm	7.95mm		.0360 kg
25-2818	25	Red	5.36mm	10.92mm	7.95mm				.0443 kg				
25-2817	25	Blue	5.36mm	10.92mm	7.95mm				.0386 kg				
25-2816	25	Orange	5.36mm	10.92mm	7.95mm				.0411 kg				
40-2822	40	Yellow	7.16mm	12.83mm	10.57mm				.0549 kg				
40-2823	40	Black	7.16mm	12.83mm	10.57mm				.0467 kg				
40-2824	40	Gray	7.16mm	12.83mm	10.57mm				.0521 kg				
40-2825	40	Red	7.16mm	12.83mm	10.57mm				.0544 kg				
40-2826	40	Blue	7.16mm	12.83mm	10.57mm	.0579 kg							
40-2827	40	Orange	7.16mm	12.83mm	10.57mm	.0602 kg							
14108	45	Yellow	Polypropylene	Matte	Extruded	7.37mm	11.61mm	11.58mm	2000.00mm	.0514 kg			
14107	45	Black				7.37mm	11.61mm	11.58mm		.0514 kg			
14110	45	Gray				7.37mm	11.61mm	11.58mm		.0514 kg			
14123	45	Red				7.37mm	11.61mm	11.58mm		.0514 kg			
14121	45	Blue				7.37mm	11.61mm	11.58mm		.0514 kg			

Reduction T-Slot Cover

Part Description:

The reduction T-slot cover slopes inward to create a flat surface and adds a finishing look while preventing dust and debris build up. It covers wires and tubes in the T-slot channel. It can also be used as panel gasket .

Tip: Use a soft faced mallet (page 906) to tap the cover into the T-slot.

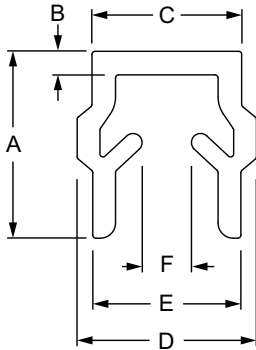

12004

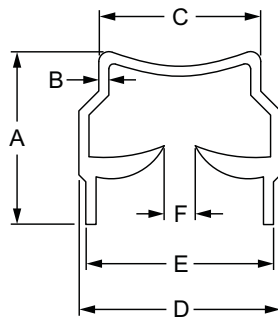

14193

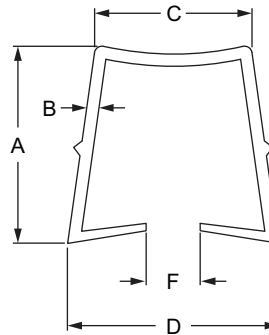

12013



Part No.	Series	Color	A	B	C	D	E	F	Stock Length	Gasket Panel Thickness	Weight
12004	20	Black	6.25mm	.79mm	5.00mm	6.00mm	4.95mm	1.65mm	2M	1 - 4mm	.0163 kg
14193	30		8.76mm	.51mm	8.20mm	10.21mm	9.50mm	1.57mm		4 - 6mm	.0358 kg
12013	45		12.80mm	.79mm	10.21mm	13.69mm	—	3.51mm		2 - 6mm	.0548 kg

Material Specifications

Material	Finish	Process
Polypropylene	Matte	Extruded

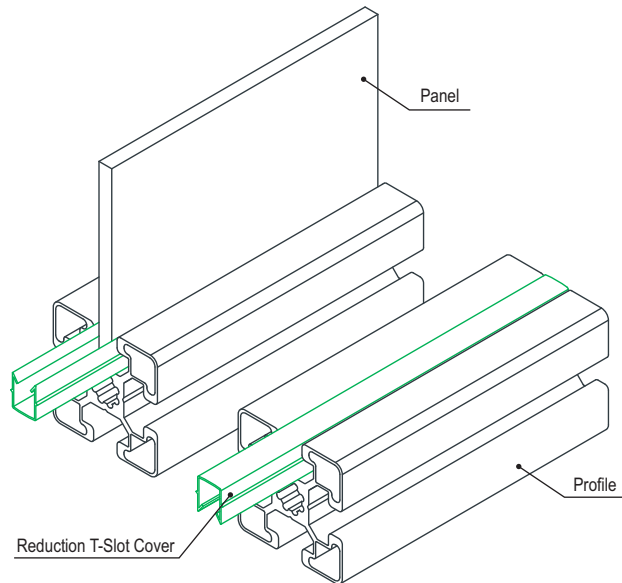

Part Description:

The rubber T-slot cover prevents dust and debris buildup, covers wires in the T-slot channel, and adds an extra layer of protection to applications. It rolls into the T-slot, making it easy to assemble.

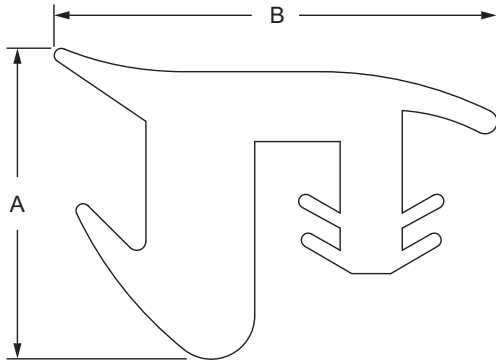

Part No.	Series	Material	Color	A	B	Length	Weight
2876	15	Rubber	Black	.400"	.570"	per foot	.042 lb / ft
2877	15			.400"	.570"	per 150 foot roll	6.315 lb
40-2876	40			10.16mm	14.48mm	per meter	.0637 kg / m
40-2877	40			10.16mm	14.48mm	per 45.7 meter roll	2.8654 kg

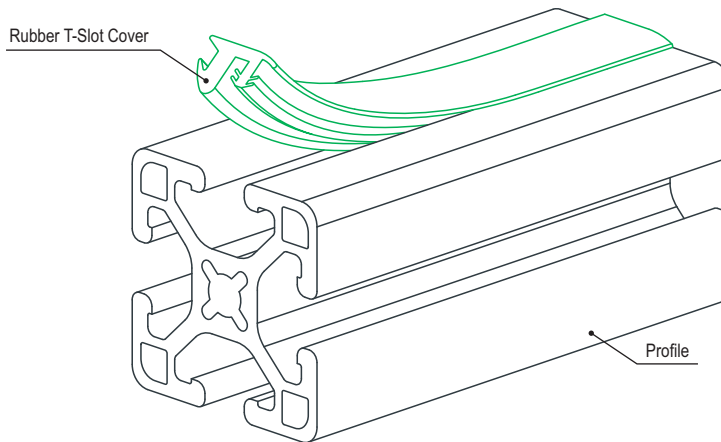

Tread Strip

Part Description:

The tread strip fits into a T-slot channel and provides an anti-slip ribbed surface. It has a key pad that presses into a T-slot and is commonly used for adding traction on steps or as padding for doors. Tread strip is sold by the foot or meter.

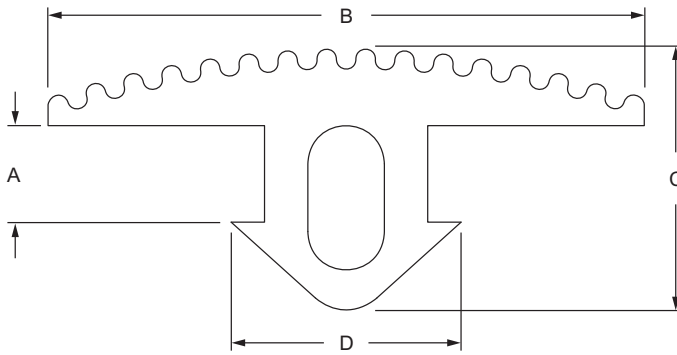

	Part No.	Series	Material	Color	A	B	C	D	Max Length	Weight
NEW	2828	10	TPV	Black	.110"	.875"	.398"	.375"	150 Feet	.055 lb / ft
NEW	25-2828	25			2.79mm	22.23mm	10.11mm	9.53mm	45 Meters	.0819 kg / m
	12006	15 40			5.03mm	31.09mm	13.59mm	11.99mm	20 Meters	.1255 kg / m

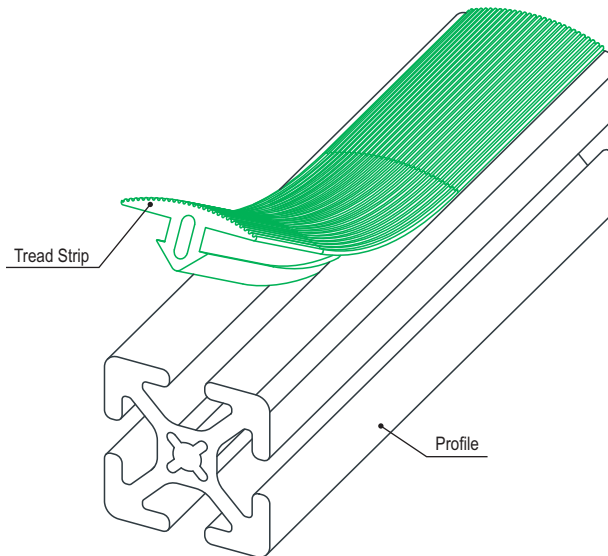

Part Description:

Wiring duct is commonly used to organize wires, cables, and tubes. It is reusable and easy to integrate into new or existing applications. The strips include overlapping fingers with no sharp edges that interlock for end-to-end attachment to enable easy access to wires with no need for a separate cover.

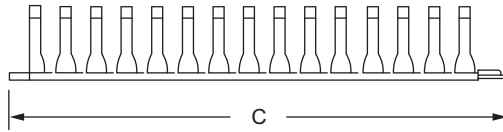
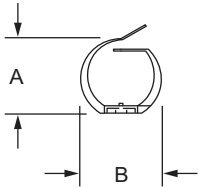

Part No.	Series	Material	Finish	Process	Color	A	B	C	Weight
2899	10 15	Plastic	Matte	Molded	Medium Gray	1.370"	1.320"	20.500"	.136 lb
65-2899	25 30 40 45					34.80mm	33.53mm	520.70mm	.0615 kg

Suggested Hardware (Mount to T-Slot)

Part No.	Series	Qty.	Bolt	T-Nut
3426	10	4	10-32 x .375" BHSCS	Slide-In
3487	15	4	10-32 x .500" BHSCS	Slide-In
11-5310	25	4	M5 x 10mm BHSCS	—
25-1954		4	—	Slide-In
11-5312	30	4	M5 x 12mm BHSCS	—
13115		4	—	Drop-In
75-3539	40	4	M5 x 12mm BHSCS	Slide-In
11-5316	45	4	M5 x 16mm BHSCS	—
13127		4	—	Drop-In

Cable Tie

Part Description:

The cable tie is used to organize wires, cables, and tubes. It has a high tensile strength. Cable ties are sold in packages of 100.

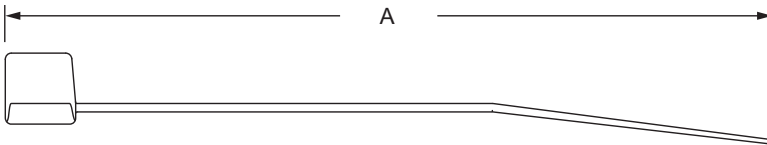
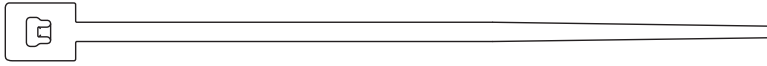

Part No.	Series	Material	Finish	Process	Color	A	Weight
2890	F M	Nylon	Matte	Molded	Black	6.000"	.001 lb
2891	F M					8.000"	.001 lb
2892	F M					11.000"	.004 lb

Part Description:

The cable tie mounting pad is used to mount cable ties (page 798) for wire and cable management and organization. All cable tie mounting pads are sold in packs of 100.

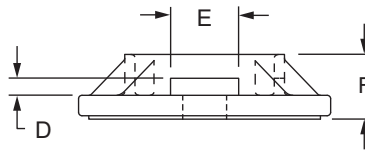
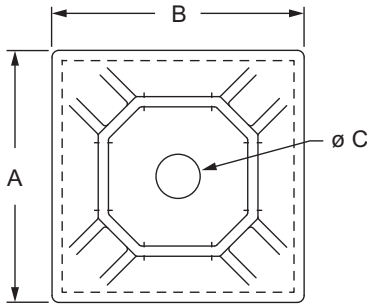

Part No.	Series	Material	Finish	Process	Color	A	B	C	D	E	F	Weight
2893	10 15 25 30 40 45	Nylon	Matte	Molded	Black	.740"	.740"	.130"	.050"	.200"	.190"	.002 lb
2894	10 15 25 30 40 45					.990"	.990"	.215"	.060"	.200"	.200"	.003 lb

* Includes a self-adhesive backing.

Suggested Hardware (Mount to T-Slot)

Series	Part No.	Qty.	Bolt	Part No.	Qty.	T-Nut
10 25	3059	1	1/4-20 x 3/8" BHSCS	3382	1	Slide-In Economy
15	3061	1	1/4-20 x 1/2" BHSCS	3382	1	Slide-In Economy
30	11-6310	1	M6 x 10mm BHSCS	13117	1	M6 Drop-In
40	11-6310	1	M6 x 10mm BHSCS	13119	1	M6 Drop-In
45	11-6314	1	M6 x 14mm BHSCS	13129	1	M6 Drop-In

CONTINUE 

Finishing Your Frame

F
Fractional

10
10 Series

15
15 Series

M
Metric

25
25 Series

30
30 Series

40
40 Series

45
45 Series

Cable Tie Mounting Pad (Continued)

80/20[®] Inc.

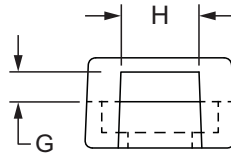
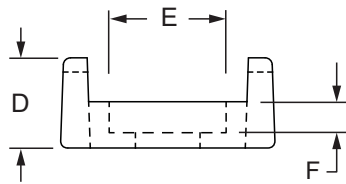
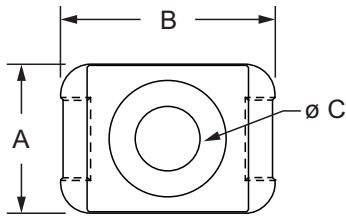

FINISH YOUR FRAME

Part No.	Series	Material	Finish	Process	Color	A	B	C	D	E	F	G	H	Weight
2895	10 15 25 30 40 45	Nylon	Matte	Molded	Black	.628"	.898"	.270"	.380"	.490"	.130"	.125"	.328"	.003 lb

Suggested Hardware (Mount to T-Slot)

Series	Part No.	Qty.	Bolt	Part No.	Qty.	T-Nut
10 25	3059	1	1/4-20 x 3/8" BHSCS	3382	1	Slide-In Economy
15	3061	1	1/4-20 x 1/2" BHSCS	3382	1	Slide-In Economy
30	11-6310	1	M6 x 10mm BHSCS	13117	1	M6 Drop-In
40	11-6310	1	M6 x 10mm BHSCS	13119	1	M6 Drop-In
45	11-6314	1	M6 x 14mm BHSCS	13129	1	M6 Drop-In

Part Description:

The drop-in cable and tube clip is used to organize cables, wires, and tubes without the need for cable ties. It is a reusable option that has a snap cover which adds an extra layer of protection and can be opened and closed repeatedly. The pad key allows it to easily drop into a T-slot channel even when ends are closed off. The drop-in cable and tube clip twists into the T-slot to lock in place.

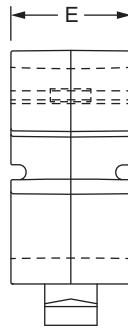
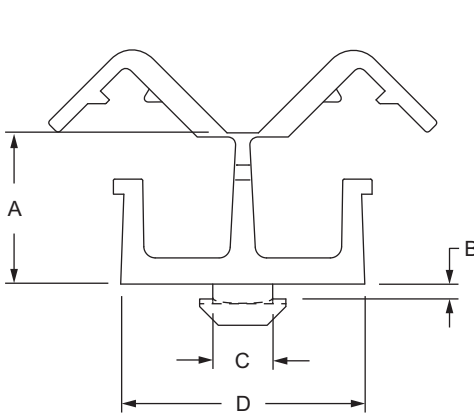

Part No.	Series	A	B	C	D	E	Weight
12321	30	20.20mm	2.00mm	8.00mm	32.33mm	16.00mm	.0066 kg
12319	15 40	20.20mm	4.50mm	8.00mm	32.33mm	16.00mm	.0077 kg
12320	45	20.20mm	8.00mm	10.00mm	32.33mm	16.00mm	.0064 kg

Material Specifications

Material	Grade	Finish	Process	Color
Nylon	PA6 GF30	Matte	Molded	Black

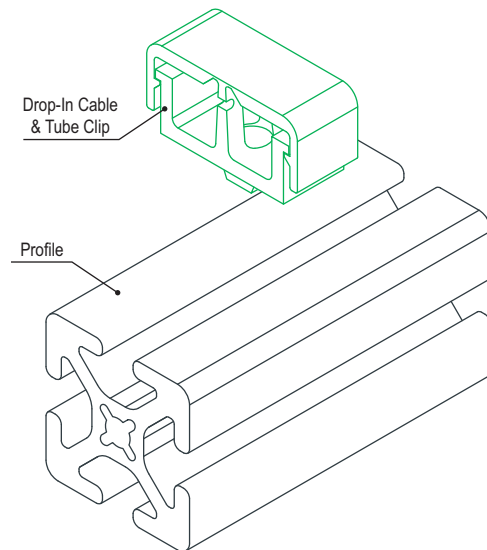

Cable & Tube Clip

Part Description:

The cable and tube clip is used to organize cables, wires, and tubes without the need for cable ties. It is a reusable option that has a snap cover which adds an extra layer of protection and can be opened and closed repeatedly. The cable clip mounts to a T-slot profile; see the suggested hardware below.

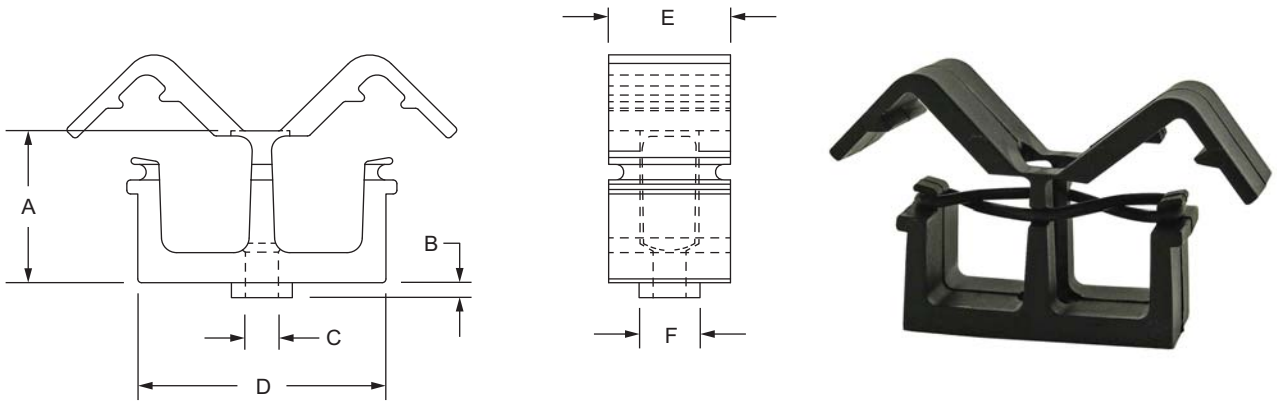

Part No.	Series	A	B	C	D	E	F	Weight
12026	15 30 40	20.20mm	2.00mm	4.30mm	32.60mm	16.00mm	8.00mm	.0100 kg
12027	45	20.20mm	2.00mm	4.30mm	32.60mm	16.00mm	10.00mm	.0077 kg

Material Specifications

Material	Grade	Finish	Process	Color
Nylon	PA6 GF30	Matte	Molded	Black

Suggested Hardware (Mount to T-Slot)

Part No.	Series	Qty.	Bolt	T-Nut
11-4512*	15 30 40	1	M4 x 12mm SHCS	—
13113*		1	—	Drop-In
75-3563	45	1	M4 x 12mm SHCS	Drop-In

*15, 30, and 40 series suggested hardware includes both part number 11-4512 & 13113.

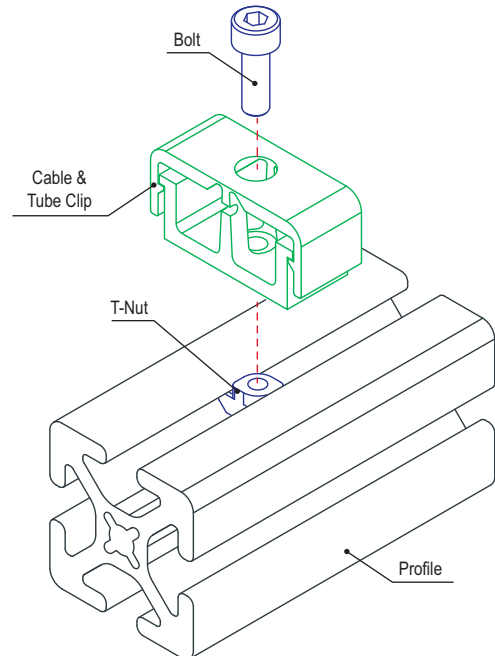

Part Description:

The cable tie mounting block is used to organize cables, wires, and tubes. It is a reusable option that allows cable ties to be attached in two directions. The pad key allows it to easily drop into a T-slot channel even when ends are closed off. The cable tie mounting block twists into the T-slot to lock in place.

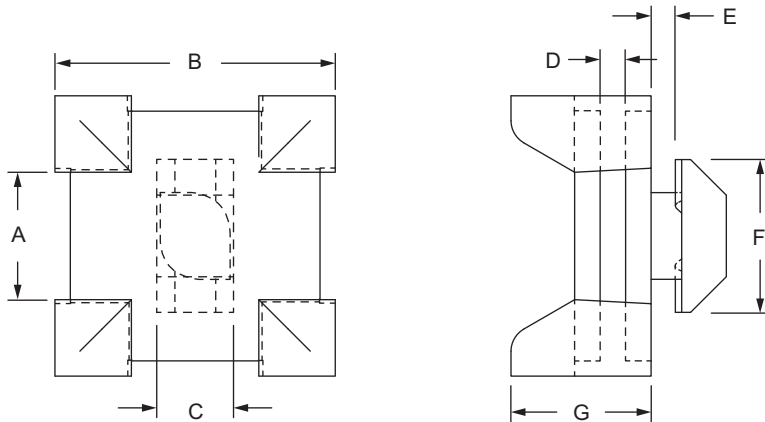

Part No.	Series	A	B	C	D	E	F	G	Weight
12314	10 25	10.00mm	22.00mm	6.00mm	2.00mm	1.90mm	12.00mm	11.00mm	.0036 kg
12317	30	10.00mm	22.00mm	7.00mm	2.00mm	2.54mm	14.00mm	11.00mm	.0036 kg
12316	15 40	10.00mm	22.00mm	8.00mm	2.00mm	4.29mm	16.00mm	11.00mm	.0045 kg
12315	45	10.00mm	22.00mm	10.00mm	2.00mm	5.80mm	18.00mm	11.00mm	.0044 kg

Material Specifications

Material	Grade	Finish	Process	Color
Nylon	PA6 GF30	Matte	Molded	Black

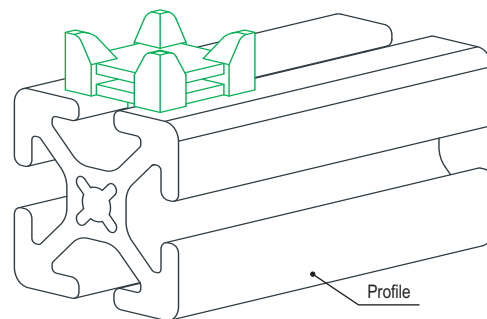
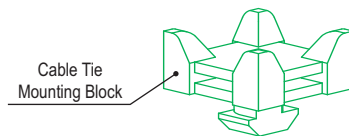

Single Cable & Tube Clamp

Part Description:

The single cable and tube clamp has one clamp channel to organize a tube, wire, or cable and attaches easily to a T-slot profile. It is made of black polypropylene which is durable, long-lasting, and resists oil, chemicals, and acids, making it ideal in industrial settings. The stackable design provides a space-saving method to organize multiple wires.

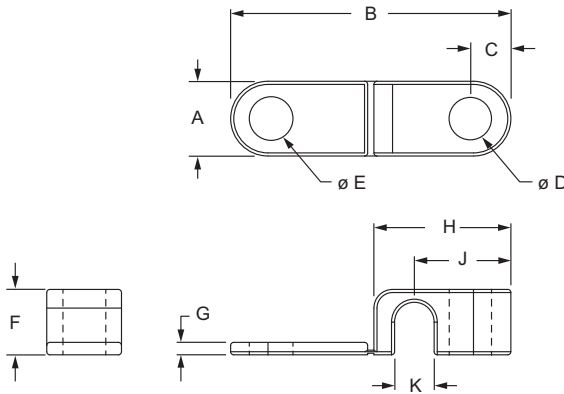

Part No.	Series	Material	Finish	Process	A	B	C	D	E	F	G	H	J	K	Weight
2500	10 15	Polypropylene	Black Matte	Molded	.472"	1.772"	.256"	.268"	.276"	.413"	.079"	.866"	.610"	.126"	.004 lb
2501	10 15				.472"	1.772"	.256"	.268"	.276"	.413"	.079"	.866"	.610"	.250"	.003 lb
2502	10 15				.630"	2.165"	.276"	.268"	.276"	.591"	.079"	1.063"	.709"	.374"	.007 lb
2503	10 15				.787"	2.717"	.276"	.268"	.276"	.886"	.079"	1.339"	.866"	.500"	.015 lb
2504	10 15				.787"	3.346"	.276"	.268"	.276"	1.181"	.079"	1.654"	1.024"	.748"	.022 lb
2505	10 15				.787"	3.346"	.276"	.268"	.276"	1.181"	.079"	1.654"	1.024"	1.000"	.021 lb
65-2500	25 40				12.00mm	45.00mm	6.50mm	6.80mm	7.00mm	10.50mm	2.00mm	22.00mm	15.50mm	3.20mm	.0017 kg
65-2501	25 40				12.00mm	45.00mm	6.50mm	6.80mm	7.00mm	10.50mm	2.00mm	22.00mm	15.50mm	6.35mm	.0015 kg
65-2502	25 40				16.00mm	55.00mm	7.00mm	6.80mm	7.00mm	15.00mm	2.00mm	27.00mm	18.00mm	9.50mm	.0033 kg
65-2503	25 40				20.00mm	69.00mm	7.00mm	6.80mm	7.00mm	22.50mm	2.00mm	34.00mm	22.00mm	12.70mm	.0068 kg
65-2504	25 40	20.00mm	85.00mm	7.00mm	6.80mm	7.00mm	30.00mm	2.00mm	42.00mm	26.00mm	19.00mm	.0099 kg			
65-2505	25 40	20.00mm	85.00mm	7.00mm	6.80mm	7.00mm	30.00mm	2.00mm	42.00mm	26.00mm	25.40mm	.0091 kg			

Suggested Hardware (Mount to T-Slot)

Part No.	Bolt Assy.	Qty.	Bolt	T-Nut
2500	3304	1	1/4-20 x 3/4" SHCS	Economy
2501	3304	1	1/4-20 x 3/4" SHCS	
2502	3306	1	1/4-20 x 1.0" SHCS	
2503	3307	1	1/4-20 x 1.25" SHCS	
2504	3308	1	1/4-20 x 1.50" SHCS	
2505	3308	1	1/4-20 x 1.50" SHCS	
65-2500	75-3414	1	M6 x 20mm SHCS	
65-2501	75-3415	1	M6 x 25mm SHCS	
65-2502	75-3415	1	M6 x 25mm SHCS	
65-2503	75-3416	1	M6 x 30mm SHCS	
65-2504	75-3418	1	M6 x 40mm SHCS	
65-2505	75-3418	1	M6 x 40mm SHCS	

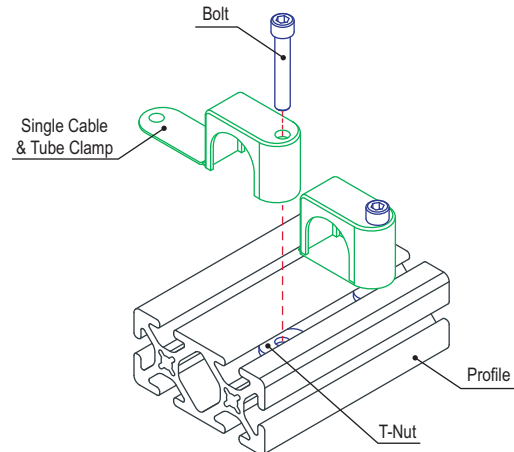

Part Description:

The double cable and tube clamp has two clamp channels to organize tubes, wires, and cables and attaches easily to a T-slot profile. It is made of black polypropylene which is durable, long-lasting, and resists oil, chemicals, and acids, making it ideal in industrial settings. The stackable design provides a space-saving method to organize multiple wires.

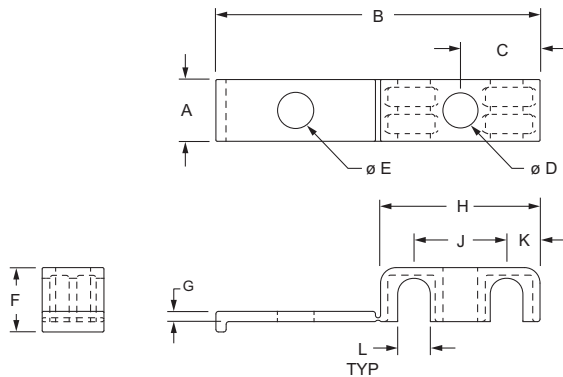

Part No.	Series	Material	Finish	Process	A	B	C	D	E	F	G	H	J	K	L	Weight
2506	10 15	Polypropylene	Black Matte	Molded	.472"	2.480"	.610"	.268"	.276"	.413"	.079"	1.220"	.709"	.256"	.126"	.005 lb
2507	10 15				.472"	2.480"	.610"	.268"	.276"	.413"	.079"	1.220"	.709"	.256"	.250"	.005 lb
2508	10 15				.630"	3.110"	.768"	.268"	.276"	.591"	.079"	1.535"	.866"	.335"	.374"	.009 lb
2509	10 15				.787"	4.213"	1.043"	.268"	.276"	.886"	.079"	2.087"	1.181"	.453"	.500"	.022 lb
2510	10 15				.787"	5.551"	1.378"	.268"	.276"	1.181"	.079"	2.756"	1.496"	.630"	.748"	.034 lb
2511	10 15				.787"	5.551"	1.378"	.268"	.276"	1.181"	.079"	2.756"	1.496"	.630"	1.000"	.026 lb
65-2506	25 40				12.00mm	63.00mm	15.50mm	6.80mm	7.00mm	10.50mm	2.00mm	31.00mm	18.00mm	6.50mm	3.20mm	.0024 kg
65-2507	25 40				12.00mm	63.00mm	15.50mm	6.80mm	7.00mm	10.50mm	2.00mm	31.00mm	18.00mm	6.50mm	6.35mm	.0023 kg
65-2508	25 40				16.00mm	79.00mm	19.50mm	6.80mm	7.00mm	15.00mm	2.00mm	39.00mm	22.00mm	8.50mm	9.50mm	.0043 kg
65-2509	25 40				20.00mm	107.00mm	26.50mm	6.80mm	7.00mm	22.50mm	2.00mm	53.00mm	30.00mm	11.50mm	12.70mm	.0099 kg
65-2510	25 40				20.00mm	141.00mm	35.00mm	6.80mm	7.00mm	30.00mm	2.00mm	70.00mm	38.00mm	16.00mm	19.00mm	.0154 kg
65-2511	25 40	20.00mm	141.00mm	35.00mm	6.80mm	7.00mm	30.00mm	2.00mm	70.00mm	38.00mm	16.00mm	25.40mm	.0117 kg			

Suggested Hardware (Mount to T-Slot)

Part No.	Bolt Assy.	Qty.	Bolt	T-Nut
2506	3304	1	1/4-20 x 3/4" SHCS	Economy
2507	3305	1	1/4-20 x 7/8" SHCS	
2508	3306	1	1/4-20 x 1.0" SHCS	
2509	3307	1	1/4-20 x 1.25" SHCS	
2510	3308	1	1/4-20 x 1.50" SHCS	
2511	3308	1	1/4-20 x 1.50" SHCS	
65-2506	75-3414	1	M6 x 20mm SHCS	
65-2507	75-3414	1	M6 x 20mm SHCS	
65-2508	75-3415	1	M6 x 25mm SHCS	
65-2509	75-3416	1	M6 x 30mm SHCS	
65-2510	75-3418	1	M6 x 40mm SHCS	
65-2511	75-3418	1	M6 x 40mm SHCS	

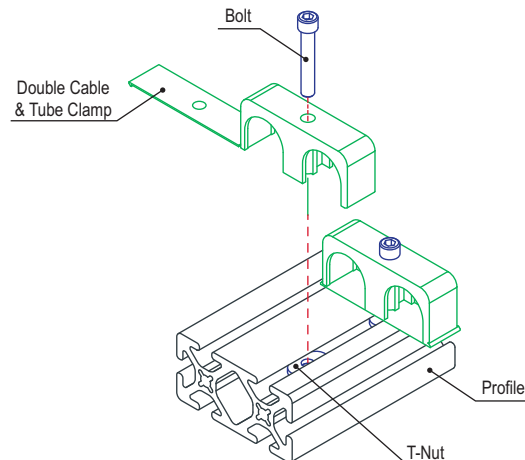

Wiremold[®] Power Strip

Part Description:

The Wiremold[®] power strip is ideal for applications that require power to many devices and is commonly used in laboratory and factory environments, offices, rack-mount applications, workbenches, and industrial solutions. It is housed in a durable, mountable encasement that allows for both vertical and horizontal installation. There are options available with 15 or 20-amps as well as a selection with a built-in circuit breaker that prevents dangerous overloads. The mounting clips and hardware to mount to a T-slot profile are included and there is no machining required.

FINISH YOUR FRAME

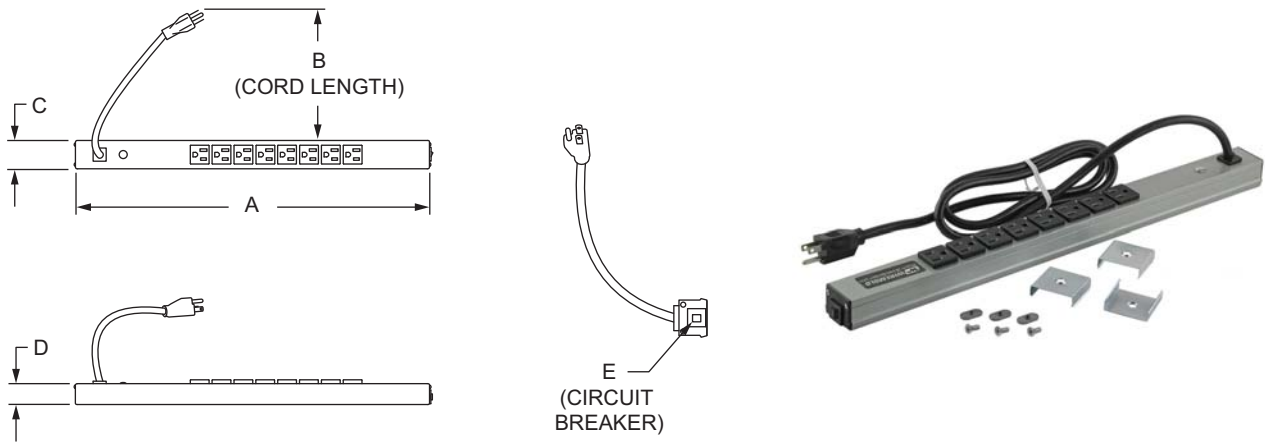

Part No.	Series	A	B	C	D	E	Surge Protection	Weight
2676	10 15 25 30 40	20.000"	6 ft	1.500"	1.190"	15 amp	NO	1.751 lb
2670	10 15 25 30 40	13.000"	6 ft	1.500"	1.190"	20 amp	NO	1.761 lb
2674	10 15 25 30 40	20.000"	6 ft	1.500"	1.190"	20 amp	YES	2.178 lb
2673	10 15 25 30 40	20.000"	15 ft	1.500"	1.190"	20 amp	NO	3.329 lb
2675	10 15 25 30 40	20.000"	15 ft	1.500"	1.190"	20 amp	YES	3.905 lb

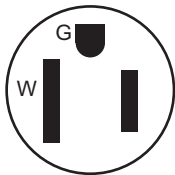

**15 Amp
Straight Blade**

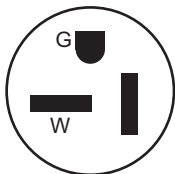

**20 Amp
Straight Blade**

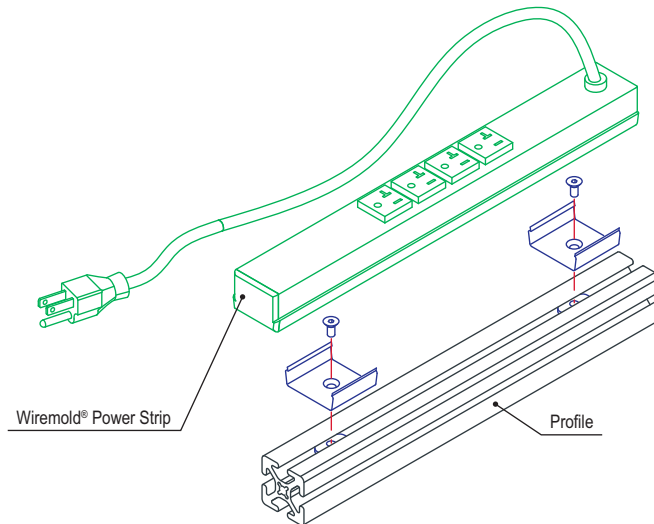

Part Description:

The anodize breaker is made of zinc-plated steel which penetrates anodize to provide a grounded application. It twists into a T-slot then tilts at a 45 degree angle. The set screw connects to the seam of the mating profile. The anodize breaker is available for 15 and 40 series profiles. **Additional Information:** This requires a 3.00mm ball end wrench; see the Tool section beginning on page 899 for options.

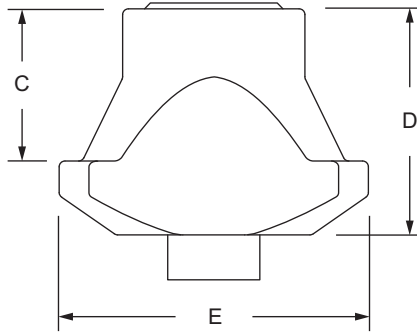
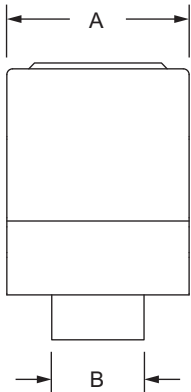

Part No.	Series	Material	Grade	Finish	A	B	C	D	E	Weight
12328	15 40	Steel	C35	Bright Zinc	.311"	.157"	.260"	.386"	.528"	.009 lb

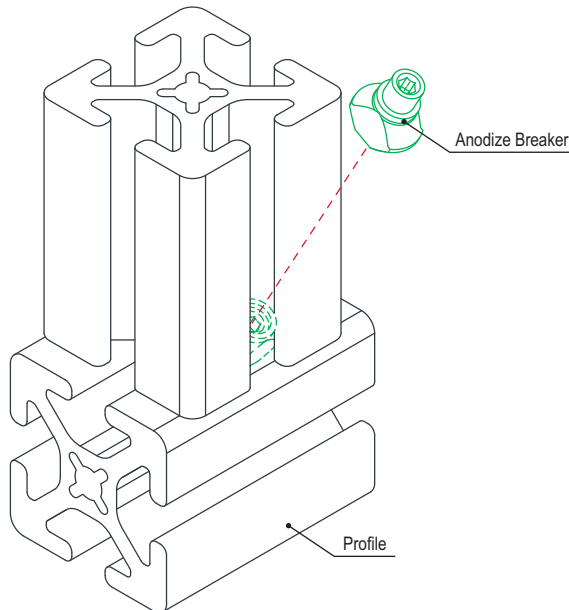

Grounding Terminal

Part Description:

The grounding terminal is made of zinc-plated steel and creates a conductive electrical connection to T-slotted profiles. It is frequently used in applications such as electronics assembly where electrostatic charges must be avoided. All hardware is included. **Additional Information:** The thread rod is an M6 thread and can be adjusted using a 3.00mm ball end wrench. See the Tool section beginning on page 899 for options.

FINISH YOUR FRAME

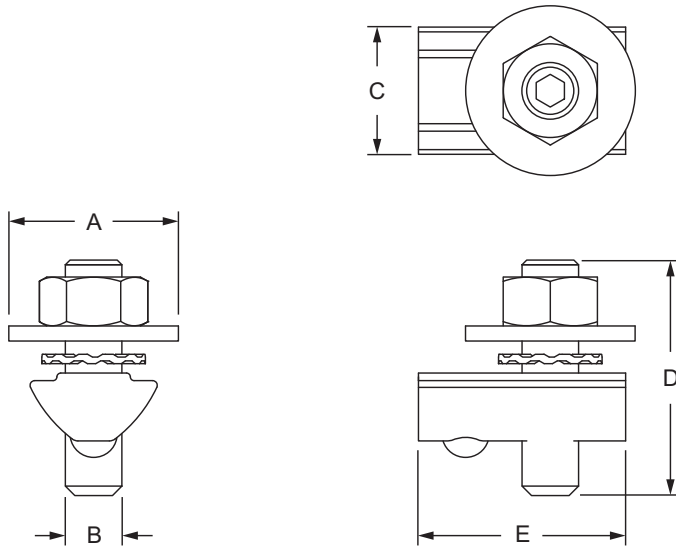

Part No.	Series	Material	Finish	Process	A	B	C	D	E	Weight
12300	15 40	Steel / Brass	Bright Zinc	Assembled	.709"	.236"	.531"	.984"	.866"	.041 lb

Part Description:

The storage bin is made of polypropylene plastic that is durable yet lightweight, perfect for customized storage systems. There are options available in red, blue, or yellow to assist with organization and there are six sizes to choose from. Bins hang from an aluminum container hanger that mounts to the T-slot profile. The storage bin hanger is sold separately (page 810).

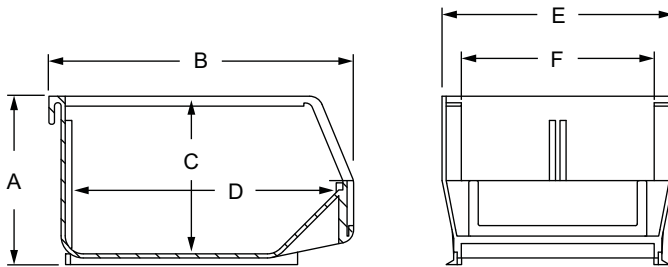

Red Bin	Blue Bin	Yellow Bin	Series	A	B	C	D	E	F	Weight
2230-RED	2230-BLU	2230-YEL	10 15	3.000"	5.375"	2.813"	4.750"	4.125"	3.438"	.156 lb
2240-RED	2240-BLU	2240-YEL	10 15	3.000"	7.375"	2.813"	6.711"	4.125"	3.438"	.232 lb
2250-RED	2250-BLU	2250-YEL	10 15	5.000"	10.875"	4.750"	10.250"	5.500"	4.375"	.644 lb
2270-RED	2270-BLU	2270-YEL	10 15	5.000"	10.875"	4.750"	10.250"	11.000"	10.000"	.984 lb
2271-RED	2271-BLU	2271-YEL	10 15	7.000"	10.750"	6.750"	10.000"	8.250"	6.563"	1.115 lb
2272-RED	2272-BLU	2272-YEL	10 15	7.000"	14.750"	6.750"	14.000"	8.250"	6.563"	1.338 lb
65-2230-RED	65-2230-BLU	65-2230-YEL	25 40	76.20mm	136.53mm	71.45mm	120.65mm	104.78mm	87.33mm	.0708 kg
65-2240-RED	65-2240-BLU	65-2240-YEL	25 40	76.20mm	187.33mm	71.45mm	170.45mm	104.78mm	87.33mm	.1030 kg
65-2250-RED	65-2250-BLU	65-2250-YEL	25 40	127.00mm	276.23mm	120.65mm	260.35mm	139.70mm	111.13mm	.2083 kg
65-2270-RED	65-2270-BLU	65-2270-YEL	25 40	127.00mm	276.23mm	120.65mm	260.35mm	279.40mm	254.00mm	.4327 kg
65-2271-RED	65-2271-BLU	65-2271-YEL	25 40	177.80mm	273.05mm	171.45mm	254.00mm	209.55mm	166.70mm	.4917 kg
65-2272-RED	65-2272-BLU	65-2272-YEL	25 40	177.80mm	374.65mm	171.45mm	355.60mm	209.55mm	166.70mm	.6069 kg

Material Specifications

Material	Finish	Process
Plastic	Gloss	Molded

Storage Bin Hanger

Part Description:

The storage bin hanger is made from aluminum and is used to mount a storage bin to an application. All mounting hardware is included. **Additional Information:** For a custom length hanger, see the storage bin hanger profile on page 846.

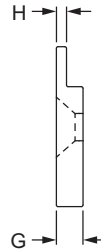
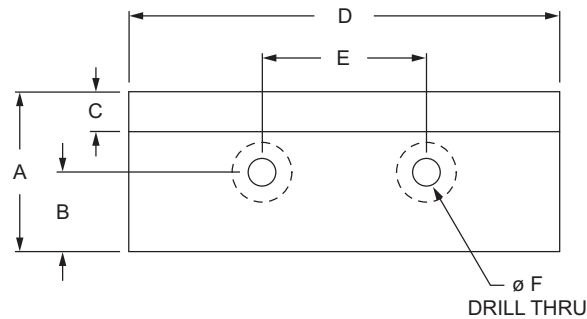

Part No.	Series	Color	A	B	C	D	E	F	G	H	Weight
2264	10 15	Clear	1.500"	.745"	.375"	6.000"	3.500"	1/4-20	.250"	.100"	.236 lb
2264-Black	10 15	Black	1.500"	.745"	.375"	6.000"	3.500"	1/4-20	.250"	.100"	.236 lb
2265	10 15	Clear	1.500"	.745"	.375"	12.000"	4.000"	1/4-20	.250"	.100"	.444 lb
2265-Black	10 15	Black	1.500"	.745"	.375"	12.000"	4.000"	1/4-20	.250"	.100"	.444 lb
65-2264	25 30 40 45	Clear	38.10mm	18.92mm	9.53mm	152.40mm	88.90mm	1/4-20	6.35mm	2.54mm	.1081 kg
65-2264-Black	25 30 40 45	Black	38.10mm	18.92mm	9.53mm	152.40mm	88.90mm	1/4-20	6.35mm	2.54mm	.1081 kg
65-2265	25 30 40 45	Clear	38.10mm	18.92mm	9.53mm	304.80mm	101.60mm	1/4-20	6.35mm	2.54mm	.2083 kg
65-2265-Black	25 30 40 45	Black	38.10mm	18.92mm	9.53mm	304.80mm	101.60mm	1/4-20	6.35mm	2.54mm	.2083 kg

Material Specifications

Material	Alloy*	Finish	Process
Aluminum	6105-T5	Anodize	Machined

* Or comparable

Included Hardware (Mount to T-Slot)

Part No.	Bolt	Qty.	Bolt	Qty.	T-Nut	Qty.
2264	3400	2	3405	2	3382	2
2264-Black	3400	2	3405	2	3382	2
65-2264	13-6712	2	13-6716	2	3859	2
65-2264-Black	13-6712	2	13-6716	2	3859	2

For parts 2265, 2265-Black, 65-2265, and 65-2265-Black the included quantity is 3.

Part Description:

The adjustable monitor mount aids ergonomic initiatives and keeps the monitor off of the work surface. It is compatible with the Video Electronics Standards Association (VESA) mounting patterns of 75x75 and 100x100, which includes most 10 to 24-inch displays. The mount supports adjustments in four dimensions; it can be swiveled ± 90 degrees, tilted ranging from 45 degrees upward to 45 degrees downward, and rotated 90 degrees. Additionally, it can be extended from the mounting surface a minimum distance of 3.1 inches (78.74mm) to a maximum of 11.0 inches (279.4mm). The mount can safely hold up to 30 pounds (13.61kg), including the weight of the mount itself.

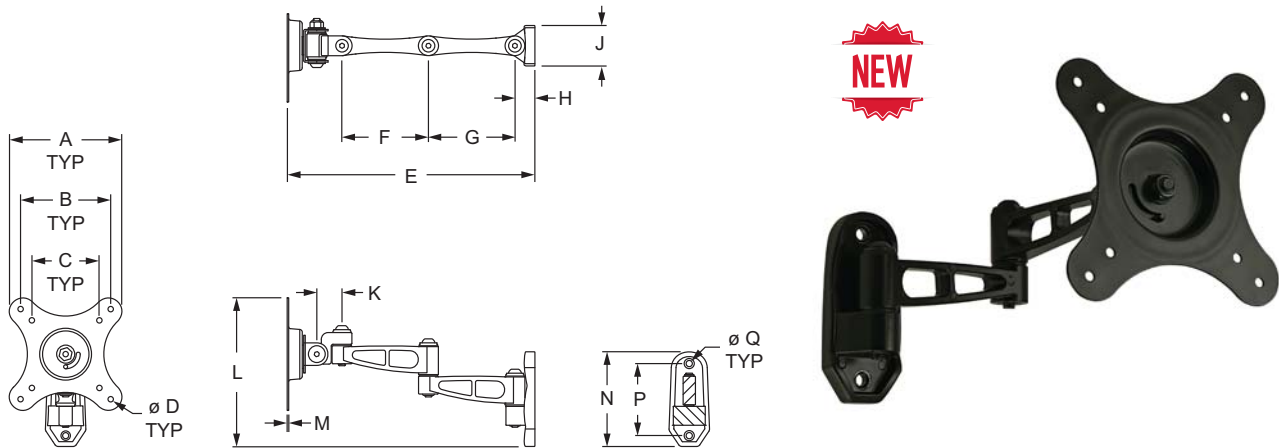

Part No.	Series	Material	Color	A	B	C	D	E	F	G
2339	15 30 40 45	Die Cast Aluminum	Black	4.921"	3.937"	2.953"	.197"	10.827"	3.780"	3.780"
		H	J	K	L	M	N	P	Q	Weight
2339	15 30 40 45	.874"	1.768"	1.102"	6.494"	.065"	4.134"	3.150"	.267"	1.310 lb

Suggested Hardware (Mount to T-Slot)

Part No.	Series	Qty.	Bolt	T-Nut
3408	15 30	2	1/4-20 x .500" BHSCS	Drop-in
75-3600	40	2	M6 x 12mm BHSCS	Drop-in
75-3602	45	2	M6 x 14mm BHSCS	Drop-in

Slide-In Tool Hanger

Part Description:

The slide-in tool hanger is made of high-strength black nylon and is ideal for hanging air tools, cable reels, and heavy door panels. It slides into a T-slot end and moves easily within the channel with no lubrication necessary. There is a hole in the hanger for a spring hook (page 813). The tool hanger has a 100 pound (68 kg.) capacity.

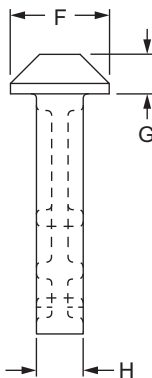
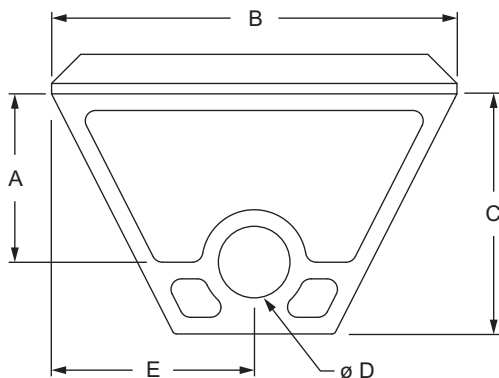

Part No.	Series	A	B	C	D	E	F	G	H	Weight
2099	10	.810"	1.950"	1.156"	.344"	.975"	.475"	.190"	.225"	.013 lb
2100	15	1.250"	2.900"	1.670"	.500"	1.450"	.625"	.250"	.250"	.030 lb
25-2099	25	20.57mm	49.53mm	29.36mm	8.74mm	24.77mm	12.07mm	4.83mm	5.72mm	.0060 kg
12016	30	21.80mm	60.00mm	33.00mm	10.50mm	30.00mm	14.00mm	4.20mm	7.50mm	.0086 kg
12015	45	21.80mm	60.00mm	33.00mm	10.50mm	30.00mm	18.00mm	4.20mm	7.50mm	.0109 kg
40-2100	40	31.75mm	73.66mm	42.42mm	12.70mm	36.83mm	15.88mm	6.35mm	6.35mm	.0138 kg

Material Specifications

Part No.	Material	Grade	Finish	Process
2099	Nylon	—	Matte	Molded
2100	Nylon	—		
25-2099	Nylon	—		
12016	Glass Filled Nylon	PA6 GF30		
12015	Glass Filled Nylon	PA6 GF30		
40-2100	Nylon	—		

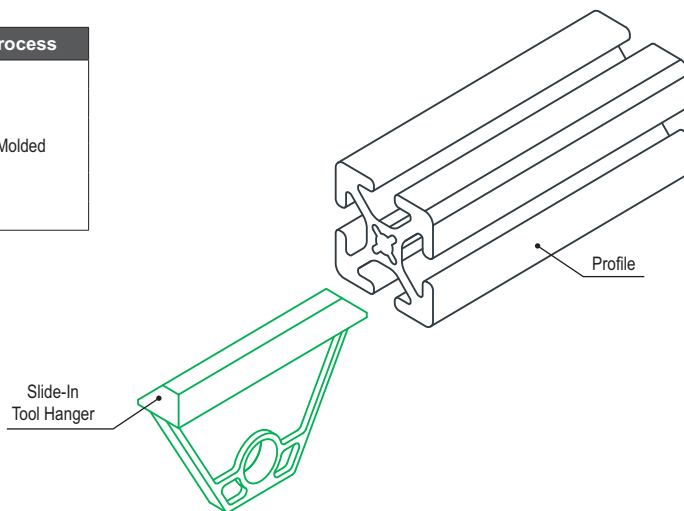

Part Description:

The tool hanger spring hook is commonly used with the slide-in tool hanger to hang cables, air tools, and reels. It makes it easy and quick to change devices and is comprised of electro-galvanized mild steel creating a strong and durable option with a 550 pound (374 kg.) breaking capacity.

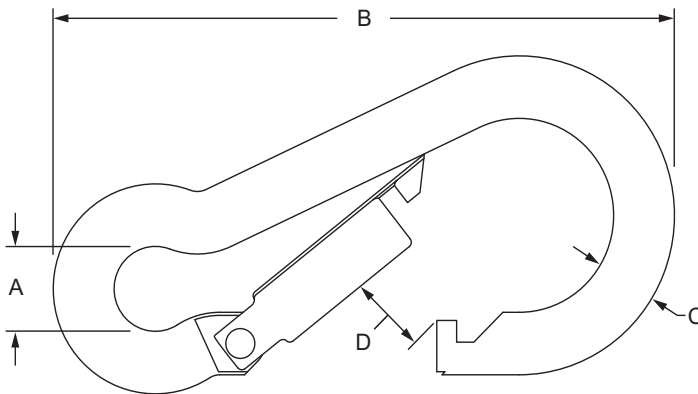

Part No.	Series	Material	Grade	Finish	Process	A	B	C	D	Weight
2108	10 15	Steel	Mild	Galvanized	Formed	.313"	2.375"	.230"	.313"	.059 lb
65-2108	25 40					7.95mm	60.33mm	5.84mm	7.95mm	.0268 kg

Tool Holder - Open Bottom

Part Description:

The tool holder – open bottom easily mounts to a T-slot profile and holds tools, such as drills and drivers, larger bottles and cups. This item is commonly used in workstations, assembly cells, and carts.

FINISH YOUR FRAME

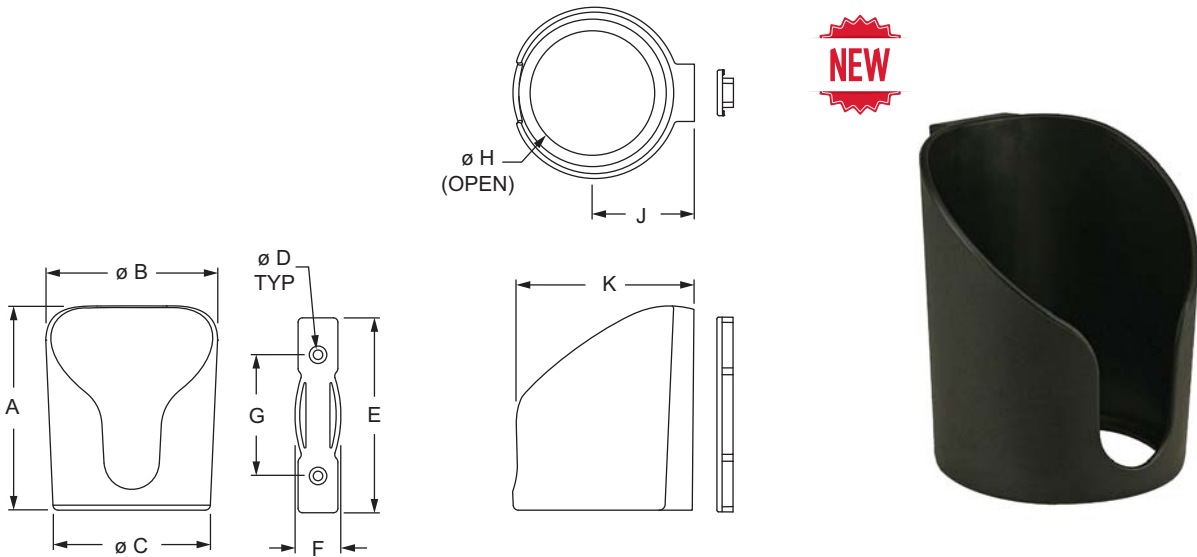

Part No.	Series	A	B	C	D	E	F	G	H	J	K	Weight
2286	10 15 25 30 40	4.606"	3.874"	3.594"	.228"	4.449"	1.023"	2.756"	2.913"	2.303"	4.045"	.321 lb

Material Specifications

Material	Process	Color
Nylon	Molded	Black

Suggested Hardware (Mount to T-Slot)

Series	Part No.	Qty.	Bolt	Part No.	Qty.	T-Nut
10	11-5716	2	M5 x 16mm FHSCS	3875	2	Roll-in
15	11-5716	2	M5 x 16mm FHSCS	3844	2	Roll-in
25	11-5716	2	M5 x 16mm FHSCS	25-1956	2	Roll-in
30	11-5716	2	M5 x 16mm FHSCS	13115	2	Drop-in
40	11-5716	2	M5 x 16mm FHSCS	40-3913	2	Roll-in

Part Description:

The cup holder – closed bottom easily mounts to a T-slot profile and holds bottles and cups. This item is commonly used in workstations, assembly cells, and carts.

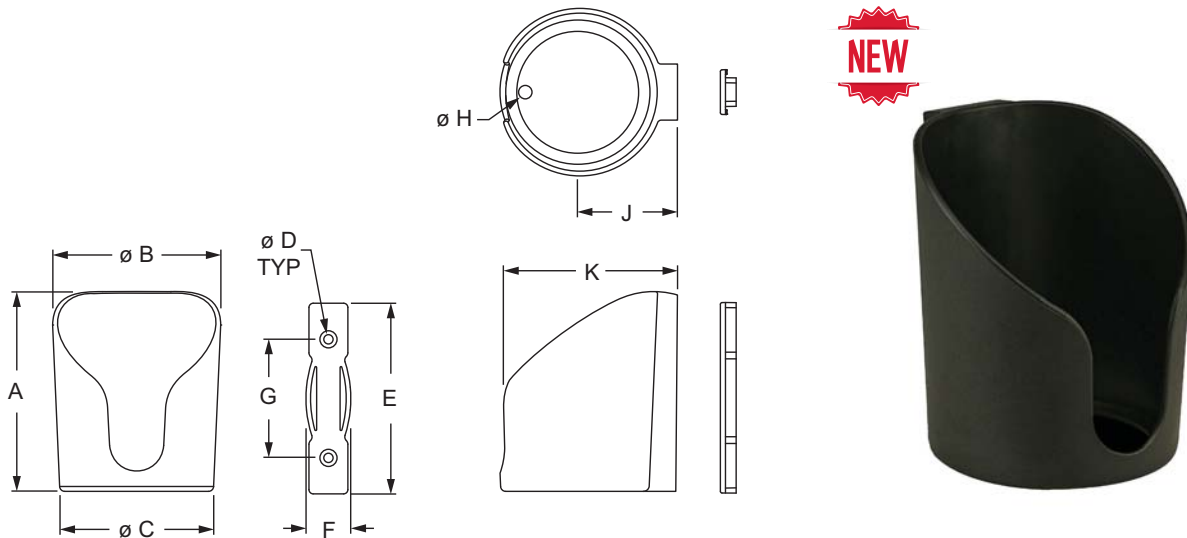

Part No.	Series	A	B	C	D	E	F	G	H	J	K	Weight
2287	10 15 25 30 40	4.606"	3.874"	3.594"	.228"	4.449"	1.023"	2.756"	.315"	2.303"	4.045"	.346 lb

Material Specifications

Material	Process	Color
Nylon	Molded	Black

Suggested Hardware (Mount to T-Slot)

Series	Part No.	Qty.	Bolt	Part No.	Qty.	T-Nut
10	11-5716	2	M5 x 16mm FHSCS	3875	2	Roll-in
15	11-5716	2	M5 x 16mm FHSCS	3844	2	Roll-in
25	11-5716	2	M5 x 16mm FHSCS	25-1956	2	Roll-in
30	11-5716	2	M5 x 16mm FHSCS	13115	2	Drop-in
40	11-5716	2	M5 x 16mm FHSCS	40-3913	2	Roll-in

Light-Duty Adhesive Clamp

Part Description:

The light-duty adhesive clamp is a black plastic holder that snaps shut to secure documents, paper, vinyl and fabric up to .040" (1.016mm) thick. It mounts with an adhesive peel and stick backing and adheres to most materials.

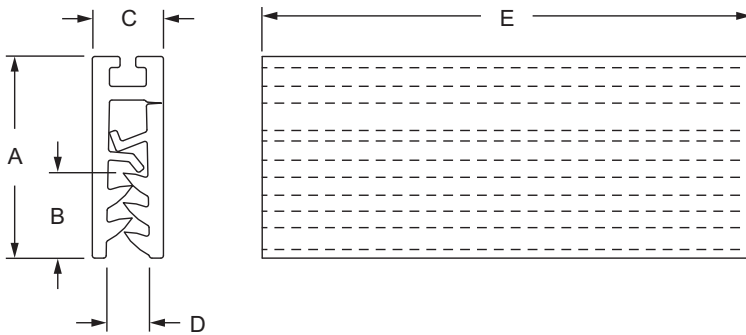

Part No.	Series	Material	Finish	Process	Color	A	B	C	D	E	Weight
2851	F M	PVC	Matte	Molded	Black	.800"	.337"	.282"	.172"	3.000"	.017 lb
2852	F M					.800"	.337"	.282"	.172"	22.000"	.140 lb
65-2851	F M					20.32mm	8.56mm	7.16mm	4.37mm	76.20mm	.0076 kg
65-2852	F M					20.32mm	8.56mm	7.16mm	4.37mm	558.80mm	.0630 kg

FINISH YOUR FRAME

Part Description:

The label holder is made of heavy-duty clear plastic with an anti-glare finish. It snaps into a T-slot to securely hold labels and is commonly used for displaying instructions or safety information. **Additional Information:** Please note that label holders are sold in packs of 25.

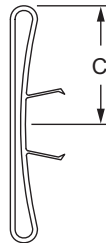
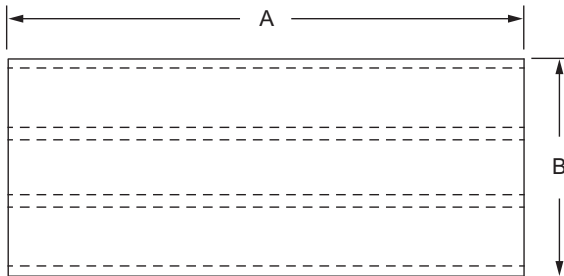

Part No.	Series	Material	Process	Color	A	B	C	Weight
2843	10	Plastic	Extruded	Clear	3.000"	1.000"	.500"	.247 lb
2844	10				6.000"	1.000"	.500"	.483 lb
2845	15				4.000"	2.000"	.630"	.699 lb
2846	15				6.000"	2.000"	.630"	1.072 lb
25-2843	25				76.20mm	25.40mm	12.70mm	.1122 kg
25-2844	25				152.40mm	25.40mm	12.70mm	.2194 kg
40-2845	40				101.60mm	50.80mm	15.90mm	.3171 kg
40-2846	40				152.40mm	50.80mm	15.90mm	.4865 kg



Rubber Bumper

Part Description:

The rubber bumper is commonly used to dampen vibrations or as a door stop or shock mount. The hardware to mount the bumper to a T-slot is included.

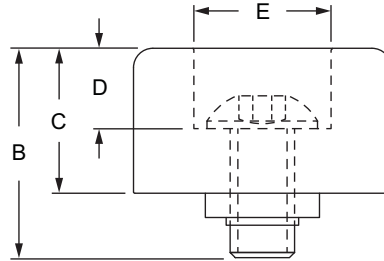
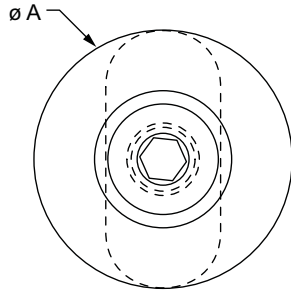



























Part No.	Series	Material	Color	A	B	C	D	E	Weight
2850	10	Rubber	Black	1.000"	.813"	.563"	.313"	.531"	.035 lb
2849	15			1.500"	1.031"	.625"	.344"	.750"	.089 lb
25-2850	25 30			25.40mm	21.95mm	14.30mm	7.95mm	13.49mm	.0186 kg
40-2849	40 45			38.10mm	26.74mm	15.88mm	8.74mm	19.05mm	.0376 kg

Included Hardware (Mount to T-Slot)

Series	Part No.	Qty.	Bolt	Part No.	Qty.	T-Nut
10	3061	1	1/4-20 x 1/2" BHSCS	3382	1	Economy
15	3330	1	5/16-18 x 11/16" FBHSCS	3278	1	Economy
25 30	11-6314	1	M6 x 14mm BHSCS	3859	1	Economy
40 45	11-8318	1	M8 x 18mm BHSCS	3838	1	Economy

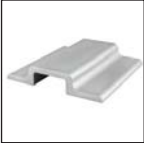
Pictorial Table Of Contents



<p>Flat Stock Profile</p>  <p>Page 821</p>	<p>Block Profile</p>  <p>Page 823</p>	<p>Square/Rectangular Tube Profile</p>  <p>Page 824</p>	<p>Inside Corner Connector Profile</p>  <p>Page 825</p>	<p>Stanchion Profile</p>  <p>Page 826</p>	<p>Aluminum Tube Profile</p>  <p>Page 827</p>	<p>Steel Tube</p>  <p>Page 828</p>
<p>Steel Solid Round</p>  <p>Page 829</p>	<p>Angle Profile</p>  <p>Page 830</p>	<p>45 Degree Gusset Profile</p>  <p>Page 832</p>	<p>Deadbolt Latch Profile</p>  <p>Page 833</p>	<p>Standard Nub Profile</p>  <p>Page 834</p>	<p>Right Angle Nub Profile</p>  <p>Page 835</p>	<p>Hinge Profile</p>  <p>Page 836</p>
<p>Roll-in Panel Mount Bracket Profile</p>  <p>Page 837</p>	<p>Panel Mount Block Profile</p>  <p>Page 838</p>	<p>Clamp Block Profile</p>  <p>Page 839</p>	<p>Single Flange Bearing Profile</p>  <p>Page 840</p>	<p>Double Flange Bearing Profile</p>  <p>Page 841</p>	<p>Single Flange UniBearing™ Profile</p>  <p>Page 842</p>	<p>Double Flange UniBearing™ Profile</p>  <p>Page 843</p>
<p>Single Retainer Profile</p>  <p>Page 844</p>	<p>Double Retainer Profile</p>  <p>Page 845</p>	<p>Storage Bin Hanger Profile</p>  <p>Page 846</p>	<p>Panel Stiffener Profile</p>  <p>Page 847</p>	<p>Tube Insert Profile</p>  <p>Page 848</p>		

Structural Shapes for Custom Solutions

Structural shapes are commonly used for custom projects; if there's a unique flat plate, manifold, bearing, or bracket you need, we have the material in stock to make it for you.

From solid aluminum plates, deadbolt latches, angle profiles, or panel mount blocks, this wide selection of in-house shapes provides a quick turn time for your design.

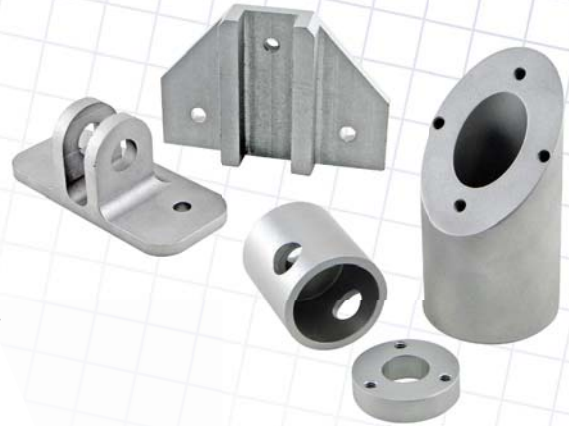

In-House Machining Capabilities

80/20 also provides an in-house Custom Machining service to modify any of our structural shapes to fit your requirements. This gives you access to a high-precision, large capacity machine shop to customize your parts quickly and accurately.

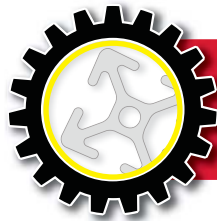

For More Info

Talk to a design technician today at 260-248-8030 to see how we can help create your custom part.

Selection of Finishes

All of the structural shapes are available with either a mill or anodize finish. We also offer black anodize to create an aesthetic look.

Mill Finish



Clear Anodize



Black Anodize



Part Description:

The flat stock profile can be cut to your desired length. It is perfect for unique custom parts such as flat plates, manifolds, and floor mounts. There are options available in a mill or anodize finish. See page 852 for the cut-to-length machining service.

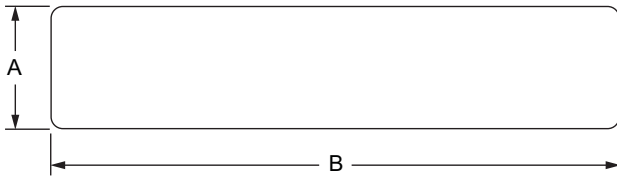

Part No.			Full Length	Series	Material	Alloy**	Process	A	B	Weight
Clear Anodize*	Natural Mill	Black Anodize*								
8303	8304	8304-Black	145"	F	Aluminum	6105-T5	Extruded	.188"	.875"	.016 lb / in.
8317	8318	8318-Black	145"	F		6105-T5		.250"	.875"	.017 lb / in.
8307	8308	8308-Black	145"	F		6105-T5		.188"	1.000"	.018 lb / in.
8310	8311	8311-Black	145"	F		6105-T5		.250"	1.000"	.025 lb / in.
8315	8316	8316-Black	144"	F		6105-T5		.500"	1.000"	.049 lb / in.
8320	8321	8321-Black	145"	F		6105-T5		.250"	1.490"	.037 lb / in.
8322	8323	8323-Black	144"	F		6105-T5		.500"	1.500"	.073 lb / in.
8325	8326	8326-Black	145"	F		6105-T5		.750"	1.500"	.108 lb / in.
8330	8331	8331-Black	145"	F		6105-T5		.188"	2.000"	.037 lb / in.
8327	8328	8328-Black	144"	F		6105-T5		.500"	2.000"	.098 lb / in.
8337	8338	8338-Black	144"	F		6105-T5		.500"	2.500"	.122 lb / in.
8335	8336	8336-Black	145"	F		6105-T5		.188"	3.000"	.055 lb / in.
8340	8341	8341-Black	145"	F		6105-T5		.250"	3.000"	.074 lb / in.
8342	8343	8343-Black	145"	F		6061-T6		.500"	3.000"	.147 lb / in.
8345	8346	8346-Black	145"	F		6105-T5		.750"	3.000"	.221 lb / in.
8360	8361	8361-Black	145"	F		6105-T5		.188"	4.000"	.075 lb / in.
8365	8366	8366-Black	144"	F		6105-T5		.250"	4.000"	.095 lb / in.
8370	8371	8371-Black	145"	F		6105-T5		.750"	4.000"	.300 lb / in.
8375	8376	8376-Black	145"	F		6105-T5		.250"	4.500"	.114 lb / in.
8385	8386	8386-Black	145"	F		6105-T5		.250"	6.000"	.146 lb / in.
8390	8391	8391-Black	145"	F	6105-T5	.375"	6.000"	.221 lb / in.		

* Longer lead times apply

** Or comparable

CONTINUE

Flat Stock Profile (Continued)

Part No.			Full Length	Series	Material	Alloy**	Process	A	B	Weight
Clear Anodize*	Natural Mill	Black Anodize*								
25-8307	25-8308	25-8308-Black	4M	M	Aluminum	6105-T5	Extruded	4.00mm	25.00mm	.0003 kg / mm
25-8310	25-8311	25-8311-Black	4M	M				6.00mm	25.00mm	.0004 kg / mm
25-8330	25-8331	25-8331-Black	4M	M				4.00mm	50.00mm	.0005 kg / mm
25-8327	25-8328	25-8328-Black	4M	M				12.00mm	50.00mm	.0016 kg / mm
25-8337	25-8338	25-8338-Black	4M	M				12.00mm	62.50mm	.0020 kg / mm
25-8335	25-8336	25-8336-Black	4M	M				4.00mm	75.00mm	.0013 kg / mm
25-8360	25-8361	25-8361-Black	4M	M				4.00mm	100.00mm	.0011 kg / mm
25-8370	25-8371	25-8371-Black	4M	M				19.00mm	100.00mm	.0051 kg / mm
40-8320	40-8321	40-8321-Black	4M	M				6.00mm	39.80mm	.0006 kg / mm
40-8322	40-8323	40-8323-Black	4M	M				12.00mm	40.00mm	.0013 kg / mm
40-8325	40-8326	40-8326-Black	4M	M				19.00mm	40.00mm	.0020 kg / mm
40-8340	40-8341	40-8341-Black	4M	M				6.00mm	80.00mm	.0013 kg / mm
40-8345	40-8346	40-8346-Black	4M	M				19.00mm	80.00mm	.0040 kg / mm
40-8375	40-8376	40-8376-Black	4M	M				6.00mm	120.00mm	.0019 kg / mm
40-8385	40-8386	40-8386-Black	4M	M				6.00mm	160.00mm	.0026 kg / mm
40-8390	40-8391	40-8391-Black	4M	M				9.00mm	160.00mm	.0025 kg / mm
NEW 45-8320	45-8321	45-8321-Black	4M	M				6.00mm	44.50mm	.0015 kg / mm
NEW 45-8340	45-8341	45-8341-Black	4M	M				6.00mm	90.00mm	.0032 kg / mm

* Longer lead times apply

** Or comparable

STRUCTURAL SHAPES

Part Description:

The block profile can be cut to your desired length. It is perfect for custom base plates and mounting blocks. There are options available in a mill or anodize finish. See page 852 for the cut-to-length machining service.

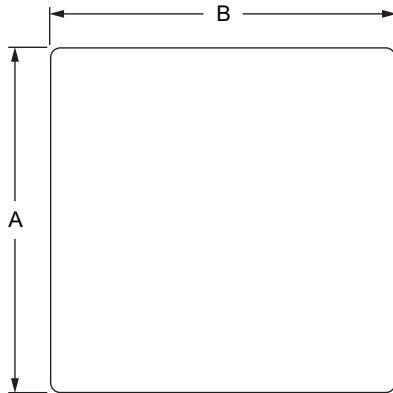

Part No.			Full Length	Series	Material	Alloy**	Process	A	B	Weight
Clear Anodize*	Natural Mill	Black Anodize*								
8313	8314	8314-Black	145"	F	Aluminum	6105-T5	Extruded	1.125"	1.125"	.124 lb / in.
8305	8306	8306-Black	145"	F		6105-T5		1.625	1.625	.259 lb / in.
8419	8319	8319-Black	144"	F		6061-T6		1.750"	1.750"	.259 lb / in.
8703	8704	8704-Black	72"	F		6105-T5		2.060"	2.060"	.424 lb / in.
8394	8395	8395-Black	144"	F		6061-T6		2.250"	2.250"	.496 lb / in.
8400	8401	8401-Black	72"	F		6105-T5		2.560"	2.560"	.651 lb / in.
8720	8721	8721-Black	72"	F		6105-T5		2.750"	2.750"	.741 lb / in.
8725	8724	8724-Black	72"	F		6061-T6		3.250"	3.250"	1.200 lb / in.
8722	8723	8723-Black	72"	F		6061-T6		3.500"	3.500"	1.200 lb / in.
8710	8711	8711-Black	145"	F		6105-T5		1.260"	2.060"	.259 lb / in.
8713	8714	8714-Black	145"	F		6105-T5		1.510"	3.060"	.462 lb / in.
8420	8392	8392-Black	72"	F		6061-T6		2.500"	3.000"	.735 lb / in.
8408	8407	8407-Black	144"	F		6061-T6		1.500"	3.500"	.784 lb / in.
8405	8406	8406-Black	72"	F		6061-T6		2.000"	4.000"	.784 lb / in.
8422	8397	8397-Black	144"	F		6061-T6		1.250"	4.500"	.551 lb / in.
8424	8399	8399-Black	72"	F		6061-T6		1.500"	6.000"	.882 lb / in.
8403	8402	8402-Black	72"	F		6061-T6		2.000"	7.000"	1.370 lb / in.

* Longer lead times apply

** Or comparable

Square/Rectangular Tube Profile

Part Description:

The square and rectangular tube profiles can be cut to your desired length. It is perfect for medium-duty projects that need an open center cavity or that don't require a T-slot channel. There are options available in a mill or anodize finish. See page 852 for the cut-to-length machining service.

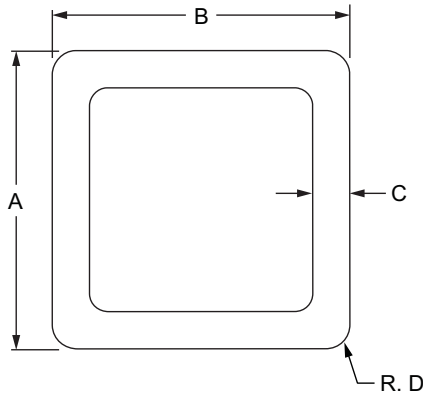

STRUCTURAL SHAPES

Part No.			Full Length	Series	Material	Alloy**	Process	A	B	C	D	Weight
Clear Anodize*	Natural Mill	Black Anodize*										
8110	8111	8111-Black	145"	F	Aluminum	6105-T5	Extruded	1.000"	1.000"	.125"	.083"	.043 lb / in.
8115	8116	8116-Black	145"	F				1.500"	1.500"	.125"	.125"	.066 lb / in.
8120	8121	8121-Black	145"	F				1.500"	3.000"	.125"	.125"	.099 lb / in.
8125	8126	8126-Black	145"	F				3.000"	3.000"	.125"	.125"	.136 lb / in.

* Longer lead times apply

** Or comparable

Part Description:

The inside corner connector profile can be cut to your desired length. There are options available in a mill or anodize finish. It is typically used to create an inside corner connector which is a strong method for forming a 90 degree connection between profiles. See page 852 for the cut-to-length machining service.

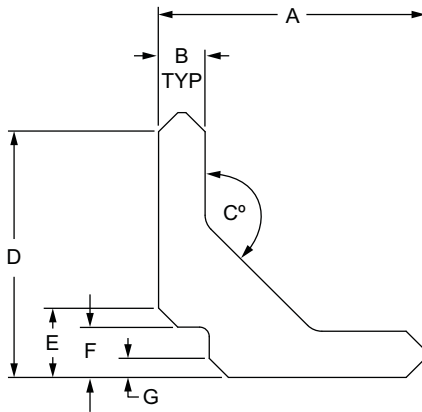

Part No.			Full Length	Series	A	B	C	D	E	F	G	Weight
Clear*	Natural	Black*										
8413	8414	8414-Black	145"	F	2.500"	.436"	135°	2.320"	.655"	.475"	.180"	.212 lb / in.

* Longer lead times apply

Material Specifications

Part No.	Material	Alloy*	Finish	Process
8413	Aluminum	6105-T5	Anodize	Extruded
8414			Mill	
8414-Black			Anodize	

* Or comparable

Stanchion Profile

Part Description:

The stanchion profile can be cut to your desired length. It is commonly used to create customized stanchions which provide multi-access positioning. There are options available in a mill or anodize finish. See page 852 for the cut-to-length machining service.

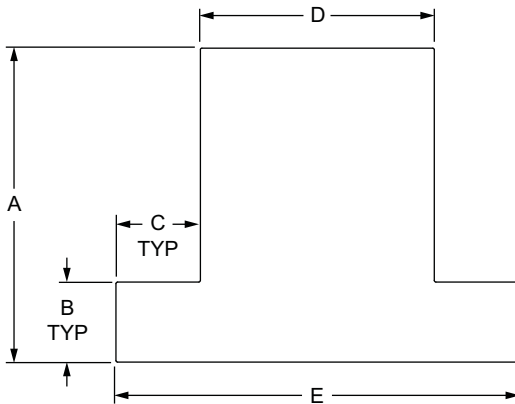

Part No.			Full Length	Series	A	B	C	D	E	Weight
Clear*	Natural	Black*								
8600	8601	8601-Black	72"	F	2.520"	.520"	.750"	1.500"	3.000"	.456 lb / in.
8605	8606	8606-Black	72"	F	3.020"	.770"	.812"	2.250"	3.874"	.804 lb / in.

* Longer lead times apply

Material Specifications

Part No.	Material	Alloy*	Finish	Process
8600	Aluminum	6105-T5	Anodize	Extruded
8601			Mill	
8601-Black			Anodize	
8605			Anodize	
8606			Mill	
8606-Black			Anodize	

* Or comparable

Part Description:

The aluminum tube profile can be cut to your desired length. It is made of 6061-T6 aluminum which provides a high strength-to-weight ratio and is commonly used with stanchions to create custom axes. It can be used for projects that need an open center cavity or that don't require a T-slot channel. There are options available in a mill or anodize finish. See page 852 for the cut-to-length machining service.

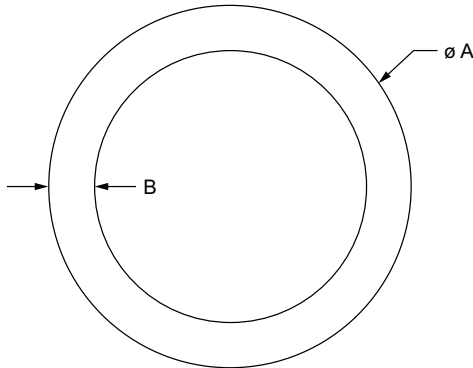

Part No.			Full Length	Series	Material	Alloy**	A	B	Weight
Clear Anodize	Natural Mill	Black Anodize*							
5035	5036	5036-Black	144"	F	Aluminum	6061-T6	1.000"	.125"	.034 lb / in.
5040	5041	5041-Black	144"	F			1.500"	.125"	.069 lb / in.
5045	5046	5046-Black	144"	F			2.000"	.125"	.100 lb / in.

* Longer lead times apply

** Or comparable

Steel Tube

Part Description:

The steel tube can be cut to your desired length. It is ground, polished, and unfinished, meaning it does not have any plating or oxide. Steel tube is commonly used with stanchions to create custom axes. See page 852 for the cut-to-length machining service.

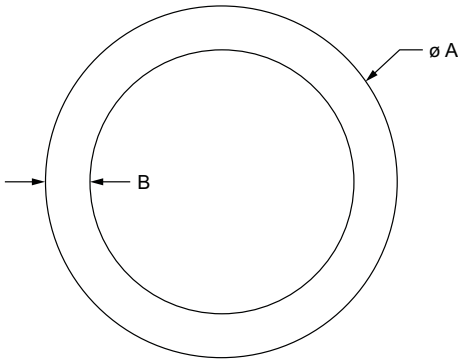

Part No.	Full Length	Series	Material	Grade	Finish	Process	Color	A	B	Weight
5005	145"	F	Carbon Steel	1020	Non-Plated	Drawn, Ground, and Polished	Unfinished	1.000"	.125"	.102 lb / in.
5015	145"	F						1.500"	.125"	.131 lb / in.
5025	145"	F						2.000"	.125"	.273 lb / in.

Part Description:

The steel solid round can be cut to your desired length. It is ground, polished, and unfinished, meaning it does not have any plating or oxide. See page 852 for the cut-to-length machining service.

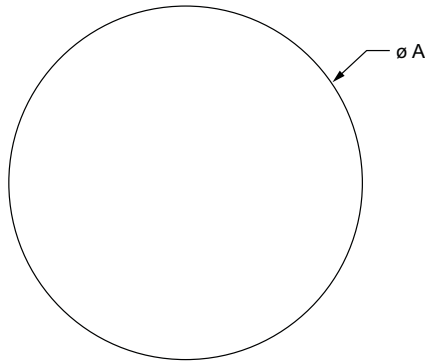

Part No.	Full Length	Series	Material	Grade	Finish	Process	Color	A	Weight
5010	145"	F	Carbon Steel	1045	Non-Plated	Drawn, Ground, and Polished	Unfinished	1.000"	.230 lb / in.
5020	145"	F						1.500"	.500 lb / in.
5030	145"	F						2.000"	.890 lb / in.

Angle Profile

Part Description:

The angle profile can be cut to your desired length. There are options available in a mill or anodize finish. The angle profile is commonly used for custom corner brackets, part bin supports, and tool hangers. See page 852 for the cut-to-length machining service.

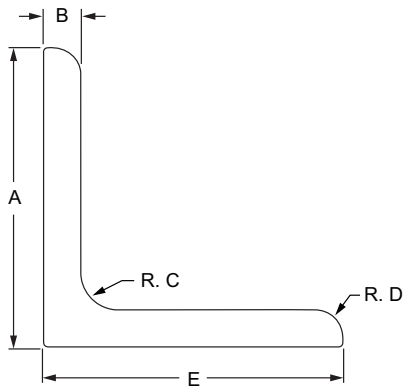

STRUCTURAL SHAPES

Part No.			Full Length	Series	Material	Alloy**	Process	A	B	C	D	E	Weight	
Clear Anodize*	Natural Mill	Black Anodize*												
	8210	8211	8211-Black	144"	F	Aluminum	6105-T5	Extruded	1.000"	.125"	.125"	.093"	1.000"	.023 lb / in.
	8217	8218	8218-Black	145"	F				1.000"	.188"	.125"	.188"	1.000"	.033 lb / in.
	8212	8213	8213-Black	145"	F				2.000"	.188"	.125"	.188"	1.000"	.053 lb / in.
	8215	8216	8216-Black	144"	F				1.500"	.188"	.125"	.188"	1.500"	.052 lb / in.
	8220	8221	8221-Black	145"	F				1.500"	.250"	.312"	.250"	1.500"	.067 lb / in.
	8230	8231	8231-Black	145"	F				3.000"	.250"	.312"	.250"	1.500"	.114 lb / in.
	8222	8223	8223-Black	145"	F				2.000"	.188"	.125"	.188"	2.000"	.070 lb / in.
	8225	8226	8226-Black	144"	F				2.500"	.188"	.125"	.188"	2.500"	.090 lb / in.
	8232	8233	8233-Black	145"	F				3.000"	.188"	.125"	.188"	3.000"	.106 lb / in.
	8235	8236	8236-Black	145"	F				3.000"	.250"	.312"	.250"	3.000"	.140 lb / in.
	8240	8241	8241-Black	145"	F				4.500"	.250"	.312"	.250"	4.500"	.218 lb / in.
NEW	20-8210	20-8211	20-8211-Black	4M	M				20.00mm	3.00mm	2.00mm	2.00mm	20.00mm	.0007 kg / mm
NEW	20-8212	20-8213	20-8213-Black	4M	M				40.00mm	3.00mm	2.00mm	2.00mm	20.00mm	.0013 kg / mm
	25-8210	25-8211	25-8211-Black	4M	M				25.00mm	3.00mm	3.00mm	3.00mm	25.00mm	.0004 kg / mm
	25-8217	25-8218	25-8218-Black	4M	M				25.00mm	4.00mm	3.00mm	4.00mm	25.00mm	.0005 kg / mm
	25-8212	25-8213	25-8213-Black	4M	M				50.00mm	4.00mm	3.00mm	4.00mm	25.00mm	.0007 kg / mm
	25-8222	25-8223	25-8223-Black	4M	M	50.00mm	4.00mm	3.00mm	4.00mm	50.00mm	.0010 kg / mm			
NEW	30-8220	30-8221	30-8221-Black	4M	M	30.00mm	4.00mm	3.50mm	3.50mm	30.00mm	.0013 kg / mm			
NEW	30-8230	30-8231	30-8231-Black	4M	M	60.00mm	4.00mm	3.50mm	3.50mm	30.00mm	.0020 kg / mm			
	40-8220	40-8221	40-8221-Black	4M	M	40.00mm	6.00mm	8.00mm	6.00mm	40.00mm	.0012 kg / mm			
	40-8230	40-8231	40-8231-Black	4M	M	80.00mm	6.00mm	8.00mm	6.00mm	40.00mm	.0018 kg / mm			
	40-8235	40-8236	40-8236-Black	4M	M	80.00mm	6.00mm	8.00mm	6.00mm	80.00mm	.0025 kg / mm			
NEW	45-8220	45-8221	45-8221-Black	4M	M	45.00mm	6.00mm	6.00mm	6.00mm	45.00mm	.0030 kg / mm			
NEW	45-8230	45-8231	45-8231-Black	4M	M	90.00mm	6.00mm	6.00mm	6.00mm	45.00mm	.0047 kg / mm			
NEW	45-8235	45-8236	45-8236-Black	4M	M	90.00mm	6.00mm	6.00mm	6.00mm	90.00mm	.0063 kg / mm			

* Longer lead times apply

** Or comparable

CONTINUE

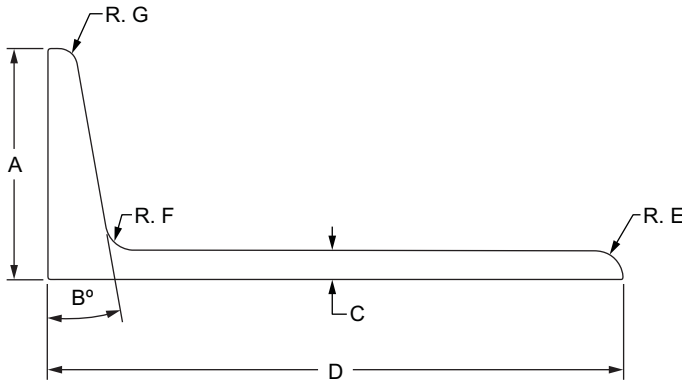

Part No.												
Clear*	Natural	Black*	Full Length	Series	A	B	C	D	E	F	G	Weight
8415	8416	8416-Black	145"	F	2.000"	10°	.250"	5.000"	.250"	.250"	.156"	.0083 lb / in.
65-8415	65-8416	65-8416-Black	4M	M	56.00mm	10°	6.00mm	140.00mm	6.00mm	6.00mm	4.00mm	.0038 kg / mm

* Longer lead times apply

Material Specifications

Part No.	Material	Alloy*	Finish	Process
8415	Aluminum	6105-T5	Anodize	Extruded
8416			Mill	
8416-Black			Anodize	
65-8415			Anodize	
65-8416			Mill	
65-8416-Black			Anodize	

* Or comparable

45 Degree Gusset Profile

Part Description:

The 45 degree gusset profile can be cut to your desired length. There are options available in a mill or anodize finish. It is commonly used for custom 90 degree connections as well as floor mounts and supports. See page 852 for the cut-to-length machining service.

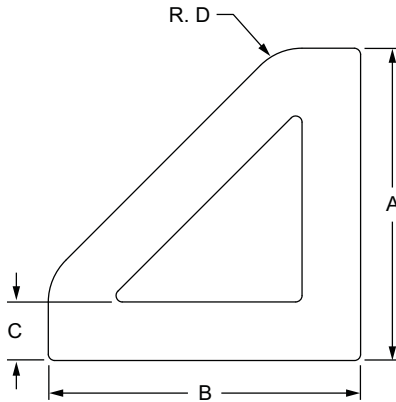

STRUCTURAL SHAPES

Part No.		Clear Anodize*	Natural Mill	Black Anodize*	Full Length	Series	Material	Alloy**	Process	A	B	C	D	Weight
	8620	8621	8621-Black	145"	F	Aluminum	6105-T5	Extruded	1.000"	1.000"	.188"	.188"	.052 lb / in.	
	8630	8631	8631-Black	145"	F				1.500"	1.500"	.250"	.250"	.106 lb / in.	
	8625	8626	8626-Black	145"	F				2.000"	2.000"	.188"	.188"	.116 lb / in.	
	8635	8636	8636-Black	145"	F				3.000"	3.000"	.250"	.250"	.234 lb / in.	
	25-8620	25-8621	25-8621-Black	4M	M				25.00mm	25.00mm	4.00mm	4.00mm	.0008 kg / mm	
	25-8625	25-8626	25-8626-Black	4M	M				50.00mm	50.00mm	4.00mm	4.00mm	.0017 kg / mm	
NEW	30-8630	30-8631	30-8631-Black	4M	M				30.00mm	30.00mm	4.00mm	4.00mm	.0021 kg / mm	
NEW	30-8635	30-8636	30-8636-Black	4M	M				60.00mm	60.00mm	4.00mm	4.00mm	.0046 kg / mm	
	40-8630	40-8631	40-8631-Black	4M	M				40.00mm	40.00mm	6.00mm	6.00mm	.0019 kg / mm	
	40-8635	40-8636	40-8636-Black	4M	M				80.00mm	80.00mm	6.00mm	6.00mm	.0040 kg / mm	
NEW	45-8630	45-8631	45-8631-Black	4M	M				45.00mm	45.00mm	6.00mm	6.00mm	.0047 kg / mm	
NEW	45-8635	45-8636	45-8636-Black	4M	M				90.00mm	90.00mm	6.00mm	6.00mm	.0102 kg / mm	

* Longer lead times apply

** Or comparable

Part Description:

The deadbolt latch profile can be cut to your desired length. It is strong and corrosion-resistant, ideal for a deadbolt latch in guarding and enclosure applications. There are options available in a mill or anodize finish. See page 852 for the cut-to-length machining service.

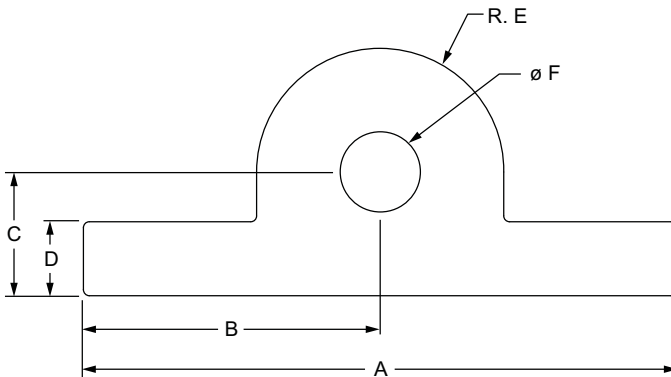

Part No.			Full Length	Series	A	B	C	D	E	F	Weight
Clear*	Natural	Black*									
8560	8561	8561-Black	145"	F	1.500"	.750"	.313"	.187"	.312"	.201"	.048 lb / in.

* Longer lead times apply

Material Specifications

Part No.	Material	Alloy*	Finish	Process
8560	Aluminum	6105-T5	Anodize	Extruded
8561			Mill	
8561-Black			Anodize	

* Or comparable

Standard Nub Profile

Part Description:

The standard nub profile can be cut to your desired length. There are options available in a mill or anodize finish. It is commonly used for custom pivot nubs and assemblies. See page 852 for the cut-to-length machining service.

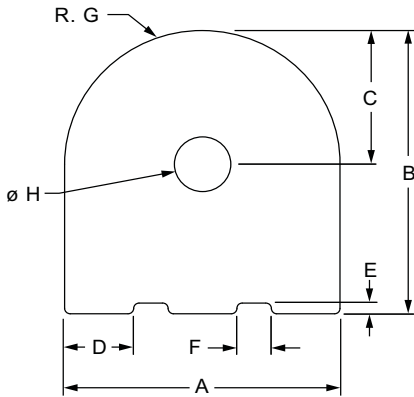

Part No.		Clear*	Natural	Black*	Full Length	Series	A	B	C	D	E	F	G	H	Weight
8547	8548	8548-Black	145"	F	1.000"	1.060"	.500"	.250"	.040"	.125"	.500"	.205"	.091 lb / in.		
8545	8546	8546-Black	145"	F	1.500"	1.600"	.750"	.314"	.080"	.279"	.750"	.265"	.205 lb / in.		
25-8547	25-8548	25-8548-Black	4M	M	25.00mm	27.00mm	12.50mm	6.40mm	2.00mm	2.90mm	12.50mm	5.00mm	.0016 kg / mm		
40-8545	40-8546	40-8546-Black	4M	M	40.00mm	42.50mm	20.00mm	8.00mm	2.13mm	8.00mm	20.00mm	6.60mm	.0039 kg / mm		

* Longer lead times apply

Material Specifications

Part No.	Material	Alloy*	Finish	Process
8547	Aluminum	6105-T5	Anodize	Extruded
8548			Mill	
8548-Black			Anodize	
8545			Anodize	
8546			Mill	
8546-Black			Anodize	
25-8547			Anodize	
25-8548			Mill	
25-8548-Black			Anodize	
40-8545			Anodize	
40-8546			Mill	
40-8546-Black			Anodize	

* Or comparable



Part Description:

The right angle nub profile can be cut to your desired length. There are options available in a mill or anodize finish. It is commonly used for custom pivot nubs and assemblies. See page 852 for the cut-to-length machining service.

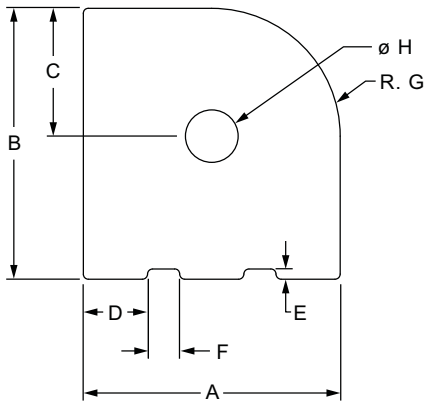

Part No.			Full Length	Series	A	B	C	D	E	F	G	H	Weight
Clear*	Natural	Black*											
8445	8446	8446-Black	145"	F	1.000"	1.060"	.500"	.250"	.040"	.125"	.500"	.205"	.096 lb / in.
8448	8449	8449-Black	145"	F	1.500"	1.600"	.750"	.314"	.080"	.279"	.750"	.265"	.218 lb / in.
25-8445	25-8446	25-8446-Black	4M	M	25.00mm	27.00mm	12.50mm	6.40mm	1.10mm	2.90mm	12.50mm	5.00mm	.0017 kg / mm
40-8448	40-8449	40-8449-Black	4M	M	40.00mm	42.50mm	20.00mm	8.00mm	2.13mm	8.00mm	20.00mm	6.80mm	.0041 kg / mm

* Longer lead times apply

Material Specifications

Part No.	Material	Alloy*	Finish	Process
8445	Aluminum	6105-T5	Anodize	Extruded
8446			Mill	
8446-Black			Anodize	
8448			Anodize	
8449			Mill	
8449-Black			Anodize	
25-8445			Anodize	
25-8446			Mill	
25-8446-Black			Anodize	
40-8448			Anodize	
40-8449			Mill	
40-8449-Black			Anodize	

* Or comparable

Hinge Profile

Part Description:

The hinge profile can be cut to your desired length. There are options available in a mill or anodize finish. It is commonly used to create custom hinge mounts for heavier-duty applications. It is also corrosion-resistant, making it useful for outdoor applications. See page 852 for the cut-to-length machining service.

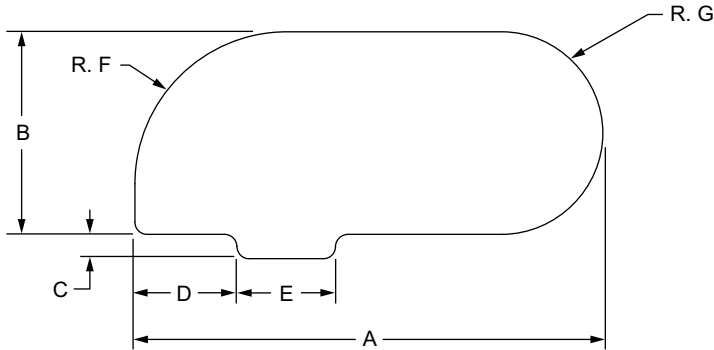

Part No.			Full Length	Series	A	B	C	D	E	F	G	Weight
Clear*	Natural	Black*										
8550	8551	8551-Black	145"	F	1.156"	.500"	.060"	.252"	.244"	.375"	.250"	.048 lb / in.
8555	8556	8556-Black	145"	F	1.655"	.500"	.100"	.469"	.309"	.375"	.250"	.075 lb / in.
25-8550	25-8551	25-8551-Black	4M	M	29.00mm	13.00mm	1.50mm	6.35mm	6.20mm	9.35mm	6.50mm	.0009 kg / mm
40-8555	40-8556	40-8556-Black	4M	M	43.94mm	13.00mm	2.60mm	12.90mm	7.85mm	9.50mm	6.50mm	.0014 kg / mm

* Longer lead times apply

Material Specifications

Part No.	Material	Alloy*	Finish	Process
8550	Aluminum	6105-T5	Anodize	Extruded
8551			Mill	
8551-Black			Anodize	
8555			Anodize	
8556			Mill	
8556-Black			Anodize	
25-8550			Anodize	
25-8551			Mill	
25-8551-Black			Anodize	
40-8555			Anodize	
40-8556			Mill	
40-8556-Black			Anodize	

* Or comparable



Part Description:

The roll-in panel mount bracket profile can be cut to your desired length. There are options available in a mill or anodize finish. It is commonly used to create custom panel mounts and is designed to be used even when profiles are captivated. See page 852 for the cut-to-length machining service.

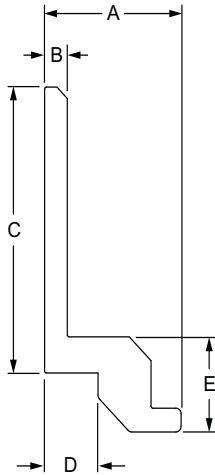

Part No.			Full Length	Series	A	B	C	D	E	Weight
Clear*	Natural	Black*								
8592	8591	8591-Black	145"	F M	.573"	.130"	1.000"	.217"	.335"	.022 lb / in.
8594	8593	8593-Black	145"	F M	.782"	.130"	1.500"	.306"	.500"	.050 lb / in.

* Longer lead times apply

Material Specifications

Part No.	Material	Alloy*	Finish	Process
8592	Aluminum	6105-T5	Anodize	Extruded
8591			Mill	
8591-Black			Anodize	
8594			Anodize	
8593			Mill	
8593-Black			Anodize	

* Or comparable

Panel Mount Block Profile

Part Description:

The panel mount block profile can be cut to your desired length. There are options available in a mill or anodize finish. It is commonly used to mount a panel flush with a profile edge or on the profile surface. There is a slot tab on the block that acts to align the mount in the T-slot. When used in this capacity, the panel mount block increases stability of the mounted panel while also reducing vibration. See page 852 for the cut-to-length machining service.

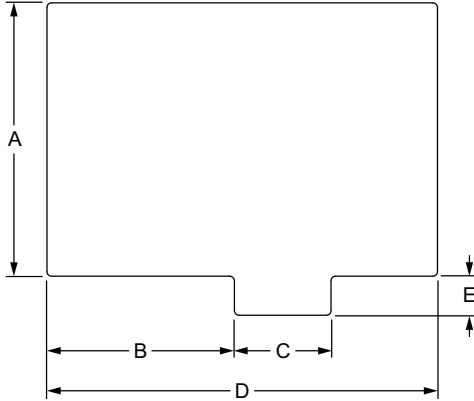

Part No.			Full Length	Series	A	B	C	D	E	Weight
Clear*	Natural	Black*								
8567	8568	8568-Black	145"	F	.700"	.370"	.250"	.812"	.050"	.058 lb / in.
8565	8566	8566-Black	145"	F	.875"	.600"	.309"	1.250"	.125"	.113 lb / in.
25-8567	25-8568	25-8568-Black	4M	M	19.00mm	9.30mm	6.30mm	20.32mm	1.30mm	.0011 kg / mm
40-8565	40-8566	40-8566-Black	4M	M	23.20mm	16.21mm	7.87mm	34.28mm	3.30mm	.0022 kg / mm

* Longer lead times apply

Material Specifications

Part No.	Material	Alloy*	Finish	Process
8567	Aluminum	6105-T5	Anodize	Extruded
8568			Mill	
8568-Black			Anodize	
8565			Anodize	
8566			Mill	
8566-Black			Anodize	
25-8567			Anodize	
25-8568			Mill	
25-8568-Black			Anodize	
40-8565			Anodize	
40-8566			Mill	
40-8566-Black			Anodize	

* Or comparable

Part Description:

The clamp block profile can be cut to your desired length. It is strong yet lightweight, and is commonly used to create custom fasteners for connecting profiles at various angles. When used in this capacity it is a repositionable and reusable fastening option. See page 852 for the cut-to-length machining service.

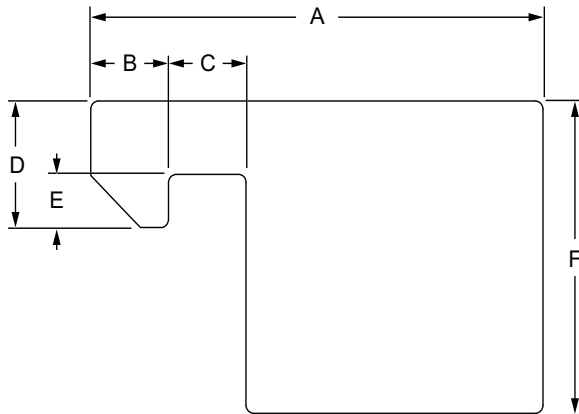

Part No.		Full Length	Series	A	B	C	D	E	F	Weight	
Clear*	Natural	Black*									
8418	8417	8417-Black	145"	10	.710"	.100"	.110"	.215"	.075"	.500"	.017 lb / in.
8426	8427	8427-Black	145"	15	1.142"	.196"	.196"	.304"	.128"	.750"	.029 lb / in.

* Longer lead times apply

Material Specifications

Part No.	Material	Alloy*	Finish	Process
8418	Aluminum	6105-T5	Anodize	Extruded
8417			Mill	
8417-Black			Anodize	
8426			Anodize	
8427			Mill	
8427-Black			Anodize	

* Or comparable

Single Flange Bearing Profile



Part Description:

The single flange bearing profile can be cut to your desired length. There are options available in a mill or anodize finish. It is commonly used in custom linear motion applications. See page 852 for the cut-to-length machining service.

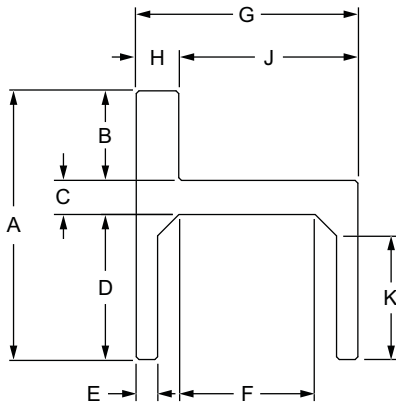

STRUCTURAL SHAPES

Part No.			Full Length	Series	A	B	C	D	E	F	G	H	J	K	Weight
Clear*	Natural	Black*													
8520	8521	8521-Black	145"	10	1.968"	.656"	.250"	1.062"	.156"	1.000"	1.624"	.311"	1.313"	.906"	.093 lb / in.
8530	8531	8531-Black	145"	15	2.750"	.750"	.375"	1.625"	.250"	1.379"	2.505"	.500"	2.005"	1.312"	.222 lb / in.
25-8520	25-8521	25-8521-Black	4M	25	49.73mm	16.48mm	5.99mm	27.25mm	3.99mm	25.22mm	41.12mm	7.98mm	33.14mm	23.29mm	.0016 kg / mm
40-8530	40-8531	40-8531-Black	4M	40	71.83mm	19.00mm	8.99mm	43.84mm	6.15mm	36.98mm	65.13mm	11.99mm	53.14mm	35.92mm	.0038 kg / mm

* Longer lead times apply

Material Specifications

Part No.	Material	Alloy*	Finish	Process
8520	Aluminum	6105-T5	Anodize	Extruded
8521			Mill	
8521-Black			Anodize	
8530			Anodize	
8531			Mill	
8531-Black			Anodize	
25-8520			Anodize	
25-8521			Mill	
25-8521-Black			Anodize	
40-8530			Anodize	
40-8531			Mill	
40-8531-Black			Anodize	

* Or comparable

Part Description:

The double flange bearing profile can be cut to your desired length. There are options available in a mill or anodize finish. It is commonly used in custom linear motion applications. See page 852 for the cut-to-length machining service.

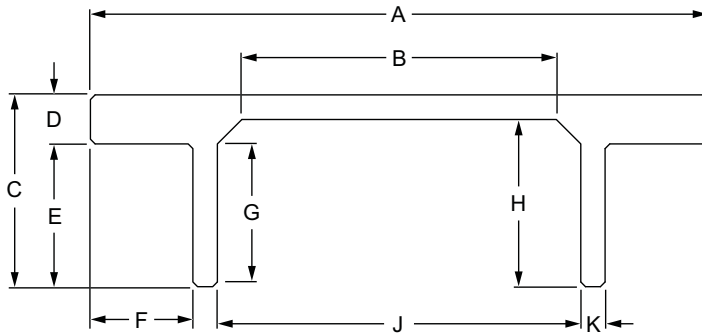

Part No.			Full Length	Series	A	B	C	D	E	F	G	H	J	K	Weight
Clear*	Natural	Black*													
8525	8526	8526-Black	145"	10	2.936"	1.000"	1.218"	.312"	.906"	.656"	.886"	1.062"	1.312"	.156"	.098 lb / in.
8527	8528	8528-Black	145"	10	3.938"	2.006"	1.218"	.312"	.906"	.654"	.876"	1.062"	2.318"	.156"	.117 lb / in.
8535	8536	8536-Black	145"	15	4.001"	1.379"	1.875"	.375"	1.500"	.748"	1.282"	1.625"	2.005"	.250"	.209 lb / in.
8540	8541	8541-Black	145"	15	5.501"	2.878"	1.875"	.375"	1.500"	.748"	1.282"	1.625"	3.504"	.250"	.247 lb / in.
25-8525	25-8526	25-8526-Black	4M	25	74.09mm	25.15mm	31.20mm	8.00mm	23.20mm	16.47mm	22.44mm	27.20mm	33.15mm	4.00mm	.0018 kg / mm
25-8527	25-8528	25-8528-Black	4M	25	99.26mm	50.34mm	31.20mm	8.00mm	23.20mm	16.47mm	22.44mm	27.20mm	58.32mm	4.00mm	.0020 kg / mm
40-8535	40-8536	40-8536-Black	4M	40	103.12mm	36.82mm	50.00mm	9.00mm	41.00mm	19.00mm	35.08mm	43.84mm	52.82mm	6.15mm	.0036 kg / mm
40-8540	40-8541	40-8541-Black	4M	40	143.31mm	77.01mm	50.00mm	9.00mm	41.00mm	19.00mm	35.08mm	43.84mm	93.01mm	6.15mm	.0042 kg / mm

* Longer lead times apply

Material Specifications

Part No.		Material	Alloy*	Finish	Process
8525	25-8525	Aluminum	6105-T5	Anodize	Extruded
8526	25-8526			Mill	
8526-Black	25-8526-Black			Anodize	
8527	25-8527			Anodize	
8528	25-8526			Mill	
8528-Black	25-8528-Black			Anodize	
8535	40-8535			Anodize	
8536	40-8536			Mill	
8536-Black	40-8536-Black			Anodize	
8540	40-8540			Anodize	
8541	40-8541			Mill	
8541-Black	40-8541-Black			Anodize	

* Or comparable

Single Flange UniBearing[™] Profile

Part Description:

The single flange UniBearing[™] profile can be cut to your desired length. There are options available in a mill or anodize finish. It is commonly used in custom linear bearing applications when there is one guiderail. See page 852 for the cut-to-length machining service.

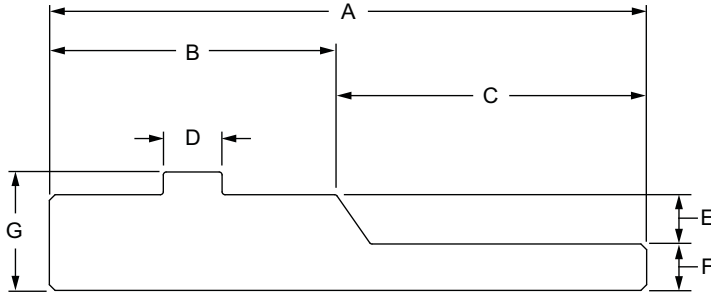

STRUCTURAL SHAPES

Part No.			Full Length	Series	A	B	C	D	E	F	G	Weight
Clear*	Natural	Black*										
8580	8581	8581-Black	145"	F	2.063"	1.000"	1.063"	.244"	.156"	.156"	.372"	.050 lb / in.
8582	8583	8583-Black	145"	F	3.125"	1.500"	1.625"	.308"	.260"	.245"	.625"	.122 lb / in.
25-8580	25-8581	25-8581-Black	3.683M	M	52.40mm	25.40mm	27.00mm	6.20mm	3.96mm	3.96mm	9.45mm	.0009 kg / mm
40-8582	40-8583	40-8583-Black	4M	M	82.45mm	38.10mm	41.28mm	7.82mm	6.60mm	6.22mm	15.88mm	.0021 kg / mm

* Longer lead times apply

Material Specifications

Part No.	Material	Alloy*	Finish	Process
8580	Aluminum	6105-T5	Anodize	Extruded
8581			Mill	
8581-Black			Anodize	
8582			Anodize	
8583			Mill	
8583-Black			Anodize	
25-8580			Anodize	
25-8581			Mill	
25-8581-Black			Anodize	
40-8582			Anodize	
40-8583			Mill	
40-8583-Black			Anodize	

* Or comparable



Part Description:

The double flange UniBearing[™] profile can be cut to your desired length. There are options available in a mill or anodize finish. It is commonly used in custom linear bearing applications when there are two guiderails. See page 852 for the cut-to-length machining service.

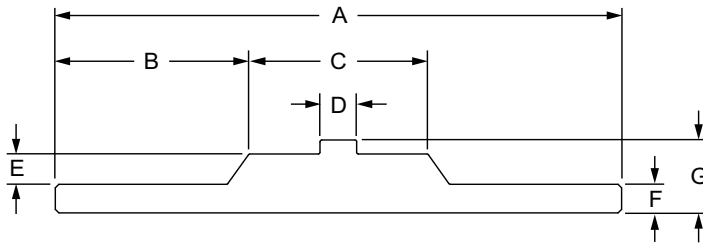

Part No.			Full Length	Series	A	B	C	D	E	F	G	Weight
Clear*	Natural	Black*										
8584	8585	8585-Black	145"	F	3.125"	1.063"	.998"	.244"	.156"	.156"	.372"	.068 lb / in.
8586	8587	8587-Black	145"	F	4.750"	1.625"	1.493"	.308"	.260"	.245"	.625"	.164 lb / in.
25-8584	25-8585	25-8585-Black	3.683M	M	79.38mm	27.00mm	25.35mm	6.20mm	4.00mm	4.00mm	9.45mm	.0012 kg / mm
40-8586	40-8587	40-8587-Black	4M	M	124.78mm	41.28mm	37.92mm	7.82mm	6.60mm	6.22mm	15.88mm	.0065 kg / mm

* Longer lead times apply

Material Specifications

Part No.	Material	Alloy*	Finish	Process
8584	Aluminum	6105-T5	Anodize	Extruded
8585			Mill	
8585-Black			Anodize	
8586			Anodize	
8587			Mill	
8587-Black			Anodize	
25-8584			Anodize	
25-8585			Mill	
25-8585-Black			Anodize	
40-8586			Anodize	
40-8587			Mill	
40-8587-Black			Anodize	

* Or comparable

Single Retainer Profile

Part Description:

The single retainer profile can be cut to your desired length. There are options available in mill or anodize finish. It is commonly used to mount a panel or mesh when it is recessed within the T-slot or on the profile frame. When used in this capacity it is a strong fastening option that is simple to use, provides stability, and reduces vibration. The single retainer profile is also frequently used when mounting one panel or mesh to a T-slot profile or in instances when larger profile series are used to mount two panels or mesh. See page 852 for the cut-to-length machining service.

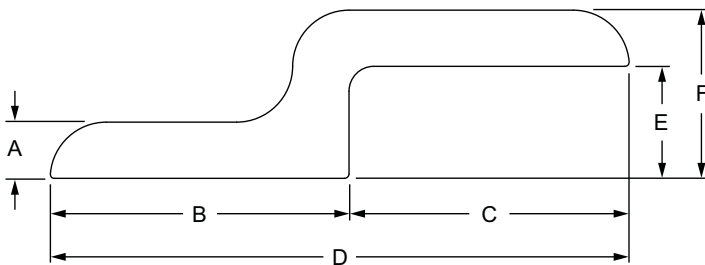

Part No.			Full Length	Series	A	B	C	D	E	F	Weight
Clear*	Natural	Black*									
8515	8516	8516-Black	145"	F	.188"	1.000"	.938"	1.938"	.375"	.563"	.042 lb / in.
8510	8511	8511-Black	145"	F	.250"	1.500"	1.379"	2.879"	.590"	.840"	.093 lb / in.
20-8515	20-8516	20-8516-Black	4M	M	3.00mm	20.00mm	19.00mm	39.00mm	7.19mm	10.19mm	.0008 kg / mm
25-8515	25-8516	25-8516-Black	4M	M	4.00mm	25.00mm	23.50mm	48.50mm	9.30mm	13.30mm	.0010 kg / mm
30-8515	30-8516	30-8516-Black	4M	M	4.00mm	30.00mm	28.00mm	58.00mm	10.59mm	14.58mm	.0016 kg / mm
40-8510	40-8511	40-8511-Black	4M	M	6.00mm	40.00mm	37.00mm	77.00mm	15.95mm	21.95mm	.0030 kg / mm
45-8510	45-8511	45-8511-Black	4M	M	6.00mm	45.00mm	41.98mm	86.98mm	17.29mm	23.29mm	.0036 kg / mm

* Longer lead times apply

Material Specifications

Part No.	Material	Alloy*	Finish	Process
8515	Aluminum	6105-T5	Anodize	Extruded
8516			Mill	
8516-Black			Anodize	
8510			Anodize	
8511			Mill	
8511-Black			Anodize	
20-8515			Anodize	
20-8516			Mill	
20-8516-Black			Anodize	
25-8515			Anodize	
25-8516			Mill	
25-8516-Black			Anodize	

Part No.	Material	Alloy*	Finish	Process
30-8515	Aluminum	6105-T5	Anodize	Extruded
30-8516			Mill	
30-8516-Black			Anodize	
40-8510			Anodize	
40-8511			Mill	
40-8511-Black			Anodize	
45-8510			Anodize	
45-8511			Mill	
45-8511-Black			Anodize	

* Or comparable



Part Description:

The double retainer profile can be cut to your desired length. There are options available in mill or anodize finish. It is commonly used to mount a panel or mesh when it is recessed within the T-slot or on the profile frame. When used in this capacity it is a strong fastening option that is simple to use, provides stability, and reduces vibration. The double retainer profile is also frequently used to create a custom retainer in instances when a T-slot profile is connecting two adjacent panels. See page 852 for the cut-to-length machining service.

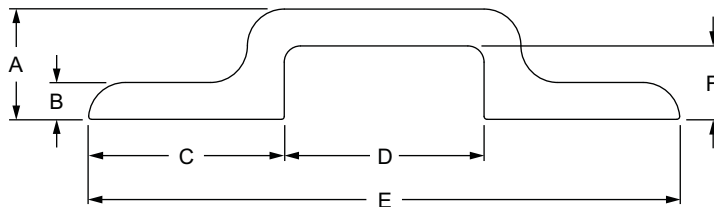

Part No.											
Clear*	Natural	Black*	Full Length	Series	A	B	C	D	E	F	Weight
8610	8611	8611-Black	145"	F	.563"	.188"	1.000"	1.020"	3.020"	.375"	.100 lb / in.
8512	8513	8513-Black	145"	F	.840"	.250"	1.500"	1.523"	4.523"	.590"	.142 lb / in.
25-8610	25-8611	25-8611-Black	4M	M	13.30mm	4.00mm	25.00mm	25.50mm	75.50mm	9.30mm	.0020 kg / mm
40-8512	40-8513	40-8513-Black	4M	M	21.95mm	6.00mm	40.00mm	40.59mm	120.59mm	15.95mm	.0060 kg / mm

* Longer lead times apply

Material Specifications

Part No.	Material	Alloy*	Finish	Process
8610	Aluminum	6105-T5	Anodize	Extruded
8611			Mill	
8611-Black			Anodize	
8512			Anodize	
8513			Mill	
8513-Black			Anodize	
25-8610			Anodize	
25-8611			Mill	
25-8611-Black			Anodize	
40-8512			Anodize	
40-8513			Mill	
40-8513-Black			Anodize	

* Or comparable

Storage Bin Hanger Profile

Part Description:

The storage bin hanger profile is typically used to mount storage bins (page 809) to an application. It is made of aluminum and available in mill or anodize finish. The storage bin profile can be cut to your desired length. See page 852 for the cut-to-length machining service.

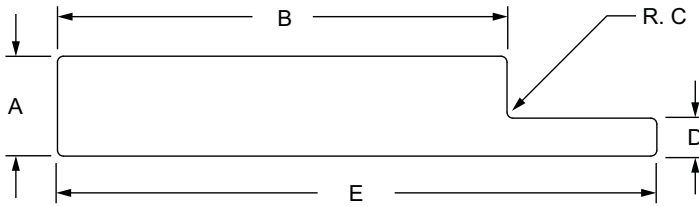

Part No.			Full Length	Series	A	B	C	D	E	Weight
Clear*	Natural	Black*								
8507	8508	8508-Black	145"	F M	.250"	1.125"	.015"	.095"	1.500"	.030 lb / in.

* Longer lead times apply

Material Specifications

Part No.	Material	Alloy*	Finish	Process
8507	Aluminum	6105-T5	Anodize	Extruded
8508			Mill	
8508-Black			Anodize	

* Or comparable

Part Description:

The panel stiffener profile can be cut to your desired length. It is made of aluminum, meaning it is strong, lightweight and corrosion-resistant. It is available with or without a handle and is commonly used to add rigidity to large .250" (6.35mm) thick panels. It easily connects to a panel using only a soft-faced mallet. See page 852 for the cut-to-length machining service.

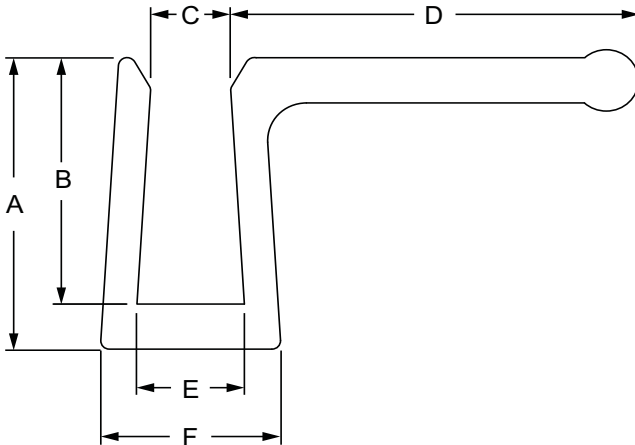

Part No.		Handle	Full Length	Series	A	B	C	D	E	F	Weight
Clear Anodize	Black Anodize*										
8570	8570-Black	Yes	145"	F	.710"	.600"	.182"	.953"	.245"	.420"	.025 lb / in.
8575	8575-Black	No	145"	F	.710"	.600"	.182"	—	.245"	.417"	.014 lb / in.
65-8570	65-8570-Black	Yes	3.68M	M	18.03mm	15.24mm	4.62mm	24.21mm	6.22mm	10.67mm	.0004 kg / mm
65-8575	65-8575-Black	No	3.68M	M	18.03mm	15.24mm	4.62mm	—	6.22mm	10.59mm	.0003 kg / mm

* Longer lead times apply

Material Specifications

Material	Alloy*	Process
Aluminum	6105-T5	Extruded

* Or comparable

Tube Insert Profile

Part Description:

The tube insert profile can be cut to your desired length. It is made of aluminum, meaning it is strong, lightweight and corrosion-resistant. It is commonly used to create a custom connector for Ready Tube profiles. See page 852 for the cut-to-length machining service.

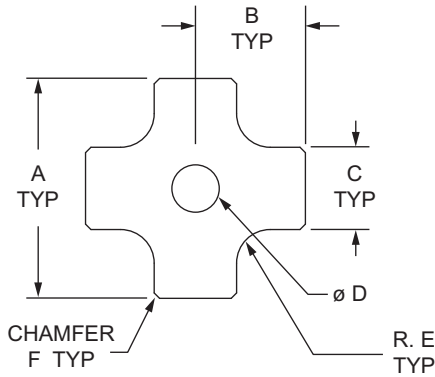

Part No.	Full Length	Series	A	B	C	D	E	F	Weight
9750	145"		1.225"	.612"	.459"	.262"	.187"	.030" X 45°	.030 lb / in.

Material Specifications

Material	Alloy*	Finish	Process
Aluminum	6105-T5	Clear Anodize	Extruded

* Or comparable



Pictorial Table Of Contents

Hidden Corner Connector Clearance Notch

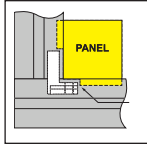

Page 887

Bolt Connector / Plate Connector Clearance Notch

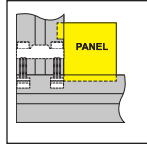

Page 888

Grabber™ Door Catch Panel Milling

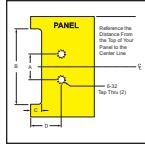

Page 889

Locking Grabber™ Handle Panel Milling

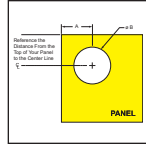

Page 889

Flush Handle Panel Milling

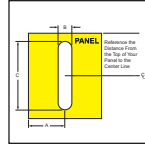

Page 890

Adjustable Tension and Detent Hinge Panel Milling

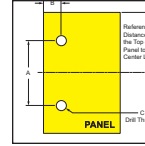

Page 891

Plastic / Steel Door Handle Panel Milling

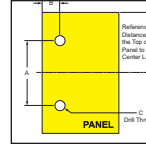

Page 892

Panel Mount Block Panel Milling

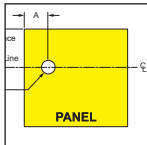

Page 893

Panel Retainer Milling

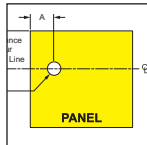

Page 894

Plastic Panel / Aluminum Plate Cutout

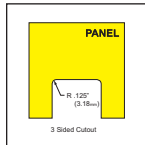

Page 895

Top Mount Milling for Plastic Panel or Aluminum Plate

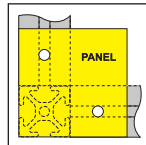

Page 896

Miscellaneous Panel Milling

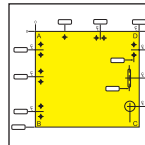

Page 897

MACHINING SERVICES

Part Description:

The T-slot profile cut-to-length machining service has a tolerance of plus or minus .015" (.38mm) with a squareness tolerance of .002" per inch (.02mm/cm) max. All profiles are washed, dried and wrapped before shipping to provide a clean product.

**T-Slot Profile Cut to Length**

Part No.	Series	Applicable Profiles	Cut Squareness	Cut Tolerance
7005	10	1001, 1001-S, 1002, 1002-S, 1003, 1003-S, 1004, 1004-S, 1010, 1010-S, 1012, 1012-S, 1050	+/- .002" / in	+/- .015"
7000	10	1020, 1020-S, 2012		
7003	10	1030, 1030-S		
7012	10	2020, 2020-S		
7013	10	2040, 2040-S		
7010	15	1501, 1501-LS, 1502, 1502-LS, 1503, 1503-LS, 1504, 1504-LS, 1515, 1515-S, 1515-Lite, 1515-LS, 1515-UL, 1515-ULS, 1517, 1517-LS, 1534-Lite, 1547, 1575		
7020	15	1530, 1530-Lite, 1530-LS, 1530-S, 3034-Lite, 3075		
7021	15	1545, 1545-S		
7030	15	3030, 3030-Lite, 3030-LS, 3030-S		
7023	15	3060		
20-7005	20	20-2020	+/- .02mm / cm	+/- .38mm
20-7020	20	20-2040		
20-7030	20	20-4040		
25-7005	25	25-2525, 25-2501, 25-2502, 25-2503, 25-2504, 25-2527, 25-2514		
25-7000	25	25-2550, 25-5013		
25-7003	25	25-2576		
25-7012	25	25-5050		
25-7013	25	25-5010		
30-7010	30	30-3001, 30-3002, 30-3003, 30-3004, 30-3030, 30-3022		
30-7020	30	30-3060		
30-7030	30	30-6060		
40-7010	40	40-4001, 40-4002, 40-4003, 40-4004, 40-4040-UL, 40-4040-Lite, 40-4040, 40-4020, 40-4030-Lite, 40-4045-Lite		
40-7020	40	40-4080-UL, 40-4080-Lite, 40-4080, 40-8020, 40-4082-Lite, 40-4083-Lite, 40-4084-Lite, 40-4085-Lite, 40-4093, 40-4094, 40-4096		
40-7021	40	40-4012		
40-7030	40	40-8080		
40-7023	40	40-8016		
45-7010	45	45-4545, 45-4545-Lite		
45-7020	45	45-4590		
45-7030	45	45-9090		

Ready Tube™ & Quick Frame™ Profile / Structural Shape Cut to Length

Part Description:

The Ready Tube, Quick Frame and structural shape cut-to-length machining services have a tolerance of plus or minus .015" (.38mm) with a square tolerance of .002" per inch (.02mm/cm) max. All profiles are washed, dried and wrapped before shipping to provide a clean product.



Ready Tube & Quick Frame Profile Cut to Length

Part No.	Series	Applicable Profiles	Cut Squareness	Cut Tolerance
7010	RT	9700, 9701	+/- .002" / in	+/- .015"
7020	RT	9705, 9706, 9725, 9726, 9728		
7310	QF	9000, 9005, 9010, 9015, 9025, 9030, 9035		

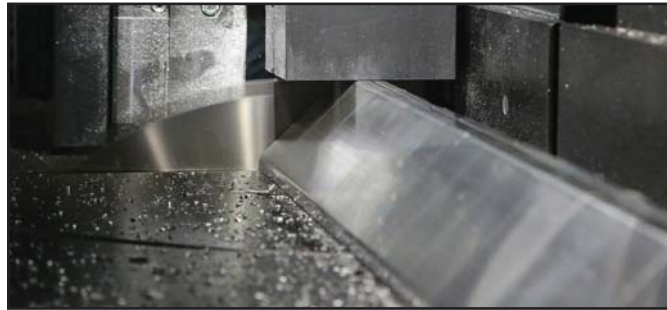

Shaped Profile Cut to Length

Part No.	Series	Service Type	Cut Squareness	Cut Tolerance
7001	F RT	Cut to Length .750" Round Connector Rod	+/- .002" / in	+/- .015"
7205	F	Cut to Length 1.00" Round Tube		
7210	F	Cut to Length 1.50" Round Tube		
7213	F	Cut to Length 2.00" Round Tube		
7212	F	Cut to Length Shapes with ALL Profile Sides < 3.250"		
7224	F	Cut to Length Shapes with ANY Profile Side ≥ 3.250"		
65-7212	M	Cut to Length Shapes with ALL Profile Sides < 82mm	+/- .02mm / cm	+/- .38mm
65-7224	M	Cut to Length Shapes with ANY Profile Side ≥ 82mm		

Part Description:

The tap profile end machining service is used to add threads to the extruded holes in a T-slot profile. This enables the insertion of a bolt to mount an end fastener or accessories. There are a wide variety of sizes and depths available. **Additional Information:** When ordering this service, designate which profile end (left, right, or both) requires the tap.

Part No.	Series	Tap Size	Minimum Depth	Service Type	Applicable Profiles
7061	10	1/4-20	1.125"	Single Hole End Tap	1001, 1001-S, 1002, 1002-S, 1003, 1003-S, 1004, 1004-S, 1010, 1010-S, 1012, 1012-S
7063	10	M6 x 1.00	1.125"	Single Hole End Tap	
7006	10	10-32	.875"	Two Hole End Tap	1050
7007	10	M5 x .80	.875"	Two Hole End Tap	
7008	10	10-32	.875"	Two Hole End Tap	2012
7009	10	M5 x .80	.875"	Two Hole End Tap	
7046	10	1/4-20	1.125"	Two Hole End Tap	1020, 1020-S
7047	10	M6 x 1.00	1.125"	Two Hole End Tap	
7036	10	1/4-20	1.125"	Three Hole End Tap	1030, 1030-S
7037	10	M6 x 1.00	1.125"	Three Hole End Tap	
7064	10	1/4-20	1.125"	Four Hole End Tap	2020, 2020-S
7067	10	M6 x 1.00	1.125"	Four Hole End Tap	
7038	10	1/4-20	1.125"	Eight Hole End Tap	2040, 2040-S
7039	10	M6 x 1.00	1.125"	Eight Hole End Tap	
7035	15	1/8 NPT	—	Single Hole End Tap	1501, 1501-LS, 1502, 1502-LS, 1503, 1503-LS, 1504, 1504-LS, 1515, 1515-S, 1515-Lite, 1515-LS, 1515-UL, 1515-ULS, 1517, 1517-LS, 1547
7060	15	5/16-18	1.250"	Single Hole End Tap	
7059	15	M8 x 1.25	1.250"	Single Hole End Tap	
7025	15	3/8-16	1.500"	Single Hole End Tap	
7053	15	M10 x 1.50	1.500"	Single Hole End Tap	
7054	15	7/16-14	1.500"	Single Hole End Tap	
7014	15	5/16-18	1.250"	Two Hole End Tap	
7015	15	M8 x 1.25	1.250"	Two Hole End Tap	
7016	15	5/16-18	1.250"	Two Hole End Tap	
7017	15	M8 x 1.25	1.250"	Two Hole End Tap	
7045	15	5/16-18	1.250"	Two Hole End Tap	1534-Lite, 1575
7048	15	M8 x 1.25	1.250"	Two Hole End Tap	
7024	15	3/8-16	1.500"	Two Hole End Tap	3034-Lite, 3075
7032	15	M10 x 1.50	1.500"	Two Hole End Tap	
7033	15	7/16-14	1.500"	Two Hole End Tap	1530, 1530-S, 1530-Lite, 1530-LS, 1530-UL, 1530-ULS
7049	15	3/8-16	1.500"	Three Hole End Tap	
7026	15	5/16-18	1.250"	Three Hole End Tap	
7028	15	M8 x 1.25	1.250"	Three Hole End Tap	
7052	15	3/8-16	1.500"	Four Hole End Tap	
7055	15	5/16-18	1.250"	Four Hole End Tap	
7056	15	M8 x 1.25	1.250"	Four Hole End Tap	
7057	15	3/8-16	1.500"	Eight Hole End Tap	
7029	15	5/16-18	1.250"	Eight Hole End Tap	
7031	15	M8 x 1.25	1.250"	Eight Hole End Tap	
20-7063	20	M5 x .80	22.23mm	Single Hole End Tap	20-2020
20-7061	20	10-32	22.23mm	Single Hole End Tap	

CONTINUE

Tap Profile End (Continued)

Part No.	Series	Tap Size	Minimum Depth	Service Type	Applicable Profiles
20-7047	20	M5 x .80	22.23mm	Two Hole End Tap	20-2040
20-7046	20	10-32	22.23mm	Two Hole End Tap	
20-7067	20	M5 x .80	22.23mm	Four Hole End Tap	20-4040
20-7064	20	10-32	22.23mm	Four Hole End Tap	
25-7061	25	1/4-20	28.58mm	Single Hole End Tap	25-2501, 25-2502, 25-2503, 25-2504, 25-2525, 25-2527
25-7063	25	M6 x 1.00	28.58mm	Single Hole End Tap	
25-7006	25	10-32	22.23mm	Two Hole End Tap	25-2514
25-7007	25	M5 x .80	22.23mm	Two Hole End Tap	
25-7008	25	10-32	22.23mm	Two Hole End Tap	25-5013
25-7009	25	M5 x .80	22.23mm	Two Hole End Tap	
25-7046	25	1/4-20	28.58mm	Two Hole End Tap	25-2550
25-7047	25	M6 x 1.00	28.58mm	Two Hole End Tap	
25-7036	25	1/4-20	28.58mm	Three Hole End Tap	25-2576
25-7037	25	M6 x 1.00	28.58mm	Three Hole End Tap	
25-7064	25	1/4-20	28.58mm	Four Hole End Tap	25-5050
25-7067	25	M6 x 1.00	28.58mm	Four Hole End Tap	
25-7038	25	1/4-20	28.58mm	Eight Hole End Tap	25-5010
25-7039	25	M6 x 1.00	28.58mm	Eight Hole End Tap	
30-7059	30	M8 x 1.25	31.75mm	Single Hole End Tap	30-3001, 30-3002, 30-3003, 30-3004, 30-3030, 30-3022
30-7060	30	5/16-18	31.75mm	Single Hole End Tap	
30-7048	30	M8 x 1.25	31.75mm	Two Hole End Tap	30-3060
30-7045	30	5/16-18	31.75mm	Two Hole End Tap	
30-7056	30	M8 x 1.25	31.75mm	Four Hole End Tap	30-6060
30-7055	30	5/16-18	31.75mm	Four Hole End Tap	
40-7060	40	5/16-18	31.75mm	Single Hole End Tap	40-4001, 40-4002, 40-4003, 40-4004, 40-4030-Lite, 40-4040, 40-4040-Lite, 40-4040-UL, 40-4045-Lite, 40-4093, 40-4094, 40-4096
40-7059	40	M8 x 1.25	31.75mm	Single Hole End Tap	
40-7025	40	3/8-16	38.10mm	Single Hole End Tap	40-4020
40-7053	40	M10 x 1.50	38.10mm	Single Hole End Tap	
40-7054	40	7/16-14	38.10mm	Single Hole End Tap	40-8020
40-7014	40	5/16-18	31.75mm	Two Hole End Tap	
40-7015	40	M8 x 1.25	31.75mm	Two Hole End Tap	40-8020
40-7016	40	5/16-18	31.75mm	Two Hole End Tap	
40-7017	40	M8 x 1.25	31.75mm	Two Hole End Tap	40-4080, 40-4080-Lite, 40-4080-UL, 40-4082-Lite, 40-4083-Lite, 40-4084-Lite, 40-4085-Lite
40-7045	40	5/16-18	31.75mm	Two Hole End Tap	
40-7048	40	M8 x 1.25	31.75mm	Two Hole End Tap	40-4012
40-7024	40	3/8-16	38.10mm	Two Hole End Tap	
40-7032	40	M10 x 1.50	38.10mm	Two Hole End Tap	40-8080
40-7033	40	7/16-14	38.10mm	Two Hole End Tap	
40-7026	40	5/16-18	31.75mm	Three Hole End Tap	40-8016
40-7028	40	M8 x 1.25	31.75mm	Three Hole End Tap	
40-7055	40	5/16-18	31.75mm	Four Hole End Tap	45-4545, 45-4545-Lite
40-7056	40	M8 x 1.25	31.75mm	Four Hole End Tap	
40-7029	40	5/16-18	31.75mm	Eight Hole End Tap	45-4590
40-7031	40	M8 x 1.25	31.75mm	Eight Hole End Tap	
45-7053	45	M12 x 1.75	38.10mm	Single Hole End Tap	45-9090
45-7054	45	1/2-13	38.10mm	Single Hole End Tap	
45-7032	45	M12 x 1.75	38.10mm	Two Hole End Tap	45-9090
45-7024	45	1/2-13	38.10mm	Two Hole End Tap	
45-7036	45	M12 x 1.75	38.10mm	Four Hole End Tap	45-9090
45-7035	45	1/2-13	38.10mm	Four Hole End Tap	

Part Description:

The access hole machining service provides clearance to the hex head of an end fastener screw, enabling the screw to be tightened. There are options available for an open (or custom) hole at any distance from the left end of the profile or drilled to predetermined locations for mounting specific profiles. **Additional Information:** When ordering open access holes, specify T-slot location from left end of profile and designate which T-slot to apply the service.

Open Style Access Hole

Part No.	Series	Service Type	Hole Diameter
7051	10	Access Hole for 10 Series Profiles	.219"
7050	15	Access Hole for 15 Series Profiles	.295"
20-7069	20	Access Hole for 20 Series Profiles	4.60mm
25-7051	25	Access Hole for 25 Series Profiles	5.50mm
30-7246	30	Access Hole for 30 Series Profiles	8.30mm
40-7050	40	Access Hole for 40 Series Profiles	7.50mm
45-7248	45	Access Hole for 45 Series Profiles	10.05mm

Ordering Example: (2) 1530 x 35.75 w/ #7050 in slot T at .750" and in slot U at .750" from Left End

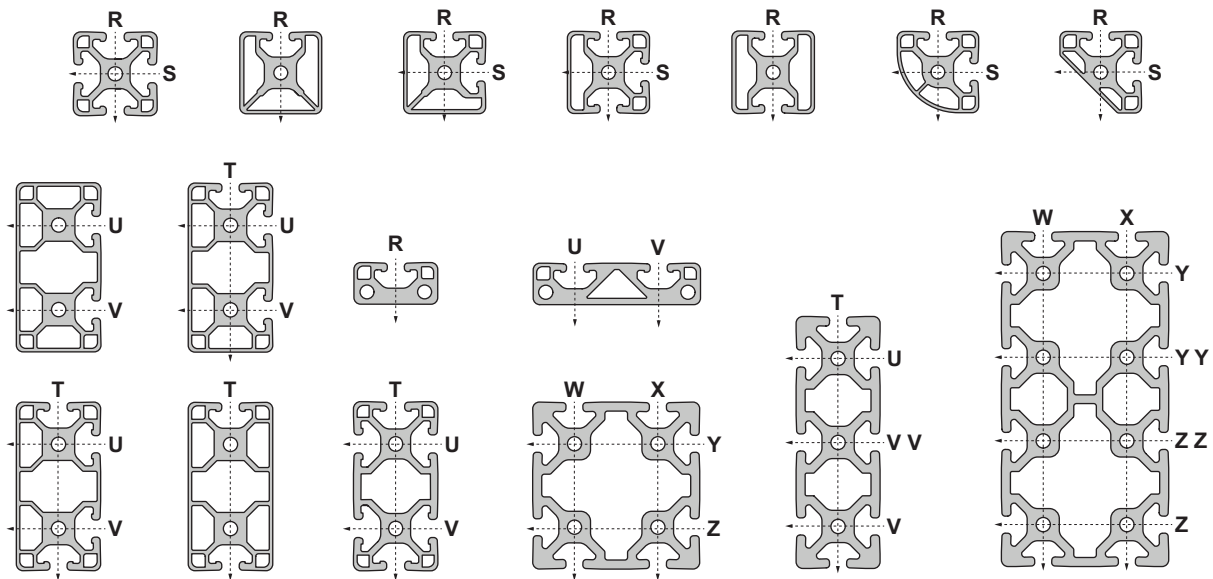
Access Hole Designations

CONTINUE

Access Hole (Continued)

80/20[®] Inc.

Predetermined Style Access Hole

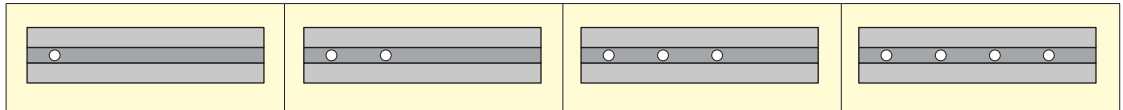

Series	One Hole Style (per T-slot)	Two Hole Style (per T-slot)	Three Hole Style (per T-slot)	Four Hole Style (per T-slot)
10	Style C (.218" Diameter Drill Thru)	Style D (.218" Diameter Drill Thru)	Style H (.218" Diameter Drill Thru)	Style J (.218" Diameter Drill Thru)
15	Style A (.295" Diameter Drill Thru)	Style B (.295" Diameter Drill Thru)	Style F (.295" Diameter Drill Thru)	Style G (.295" Diameter Drill Thru)
20	Style MN (4.60mm Diameter Drill Thru)	Style MO (4.60mm Diameter Drill Thru)	—	—
25	Style MC (5.50mm Diameter Drill Thru)	Style MD (5.50mm Diameter Drill Thru)	Style MH (5.50mm Diameter Drill Thru)	Style MJ (5.50mm Diameter Drill Thru)
30	Style MR (8.30mm Diameter Drill Thru)	Style MS (8.30mm Diameter Drill Thru)	—	—
40	Style MA (7.50mm Diameter Drill Thru)	Style MB (7.50mm Diameter Drill Thru)	Style MF (7.50mm Diameter Drill Thru)	Style MG (7.50mm Diameter Drill Thru)
45	Style MV (10.00mm Diameter Drill Thru)	Style MW (10.00mm Diameter Drill Thru)	—	—

Measuring Example (Example uses 15 Series)

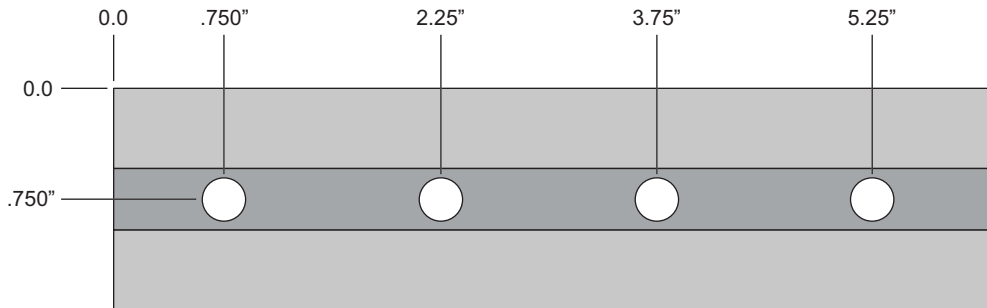

DO NOT CHAIN DIMENSION YOUR DRAWING!

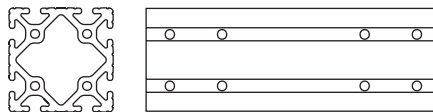

Ordering Example:

(1) 3030 x 12.00" w/ #7050 Style B in
Y and Z left end, #7050 Style B in Y and Z right end.

Anchor Fastener Counterbore / Butt Fastener Counterbore

Part Description:

The anchor fastener and butt fastener counterbore services allow an anchor fastener or butt fastener face to be flush with the profile surface. It is required when using either of these fasteners for a profile connection. See pages 212-215 for information on anchor fasteners and page 216 for butt fasteners. **Additional Information:** When ordering this service, designate which profile end (left, right, or both) requires the counterbore.

Anchor Fastener Part No.	Butt Fastener Part No.	Series	Counterbore Size
7042	7043	10	.563" Diameter x .425" Deep
7040	7041	15	.813" Diameter x .660" Deep
7117*	7118*	15	20.00mm Diameter x 16.69mm Deep
20-7042	—	20	12.00mm Diameter x 9.09mm Deep
25-7042	25-7043	25	14.30mm Diameter x 10.72mm Deep
30-7044	—	30	15.88mm Diameter x 13.21mm Deep
40-7044	40-7049	40	20.00mm Diameter x 16.69mm Deep
40-7115**	40-7116**	40	.813" Diameter x .660" Deep

*40 Series Counterbore Machined for 15 Series

**15 Series Counterbore Machined for 40 Series

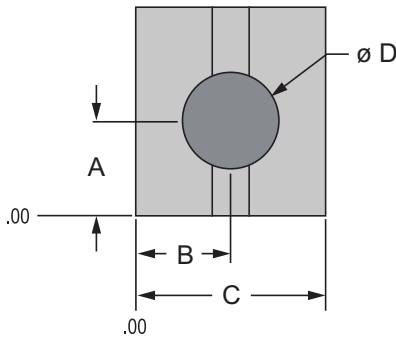

Anchor Fastener Counterbore Details				
Series	A	B	C	D
10	.406"	.500"	1.000"	.563" x .425" Deep
15	.855"	.750"	1.500"	.813" x .660" Deep
20	10.00mm	10.00mm	20.00mm	12.00mm x 9.09mm Deep
25	10.31mm	12.50mm	25.00mm	14.30mm x 10.72mm Deep
30	15.88mm	15.00mm	30.00mm	15.90mm x 13.21mm Deep
40	19.99mm	20.00mm	40.00mm	20.00mm x 16.69mm Deep

Butt Fastener Counterbore Details				
Series	A	B	C	D
10	.406"	.500"	1.000"	.563" x .425" Deep
15	.721"	.750"	1.500"	.813" x .660" Deep
25	10.31mm	12.50mm	25.00mm	14.30mm x 10.72mm Deep
40	19.99mm	20.00mm	40.00mm	20.00mm x 16.69mm Deep

Ordering Example: (3) 1530 x 35.75 w/ #7040 at F, G, in Left End and at H in Right End

Anchor Fastener Designations

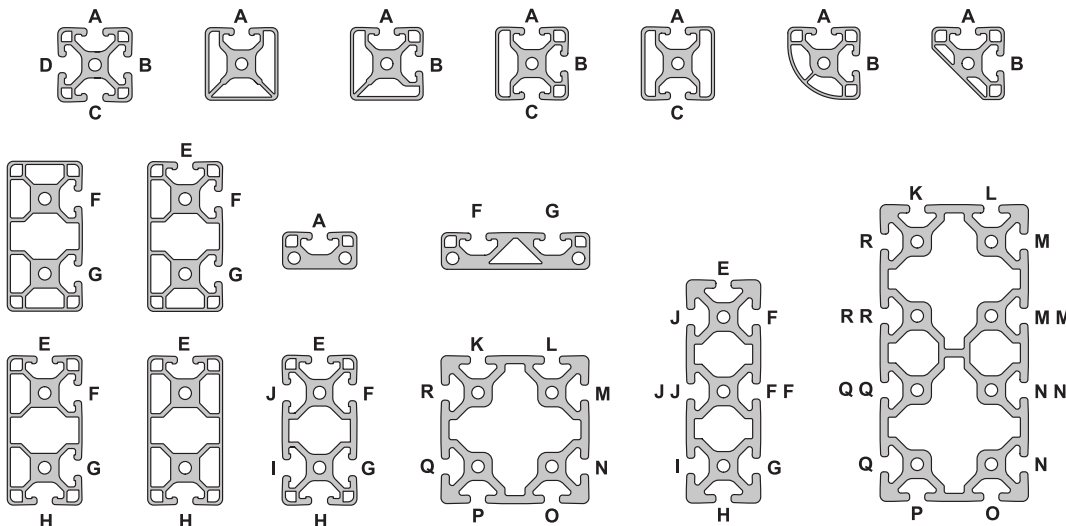

Drill Thru & Counterbore

80/20[®] Inc.

Part Description:

The drill thru and counterbore machining service creates a hole for bolting through T-slot profiles. It includes both the drill thru and the counterbore. **Additional Information:** When ordering this service, designate T-slot position from left end of profile.

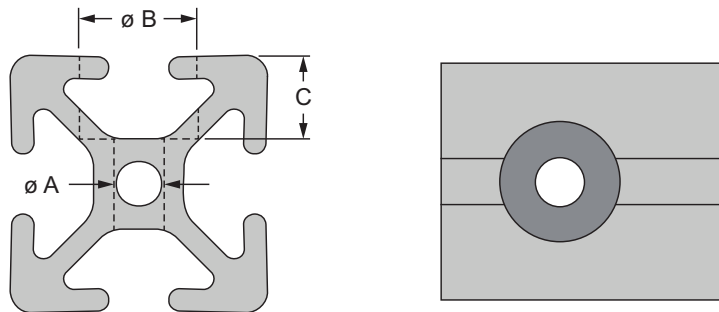

Part No.	Series	A	B	C
7256	10	.257"	.406"	.328"
7257	15	.328"	.531"	.495"
25-7256	25	6.53mm	10.31mm	8.33mm
30-7257	30	8.33mm	13.49mm	9.27mm
40-7257	40	8.33mm	13.49mm	12.70mm

Ordering Example: (2) 1530 x 24.00 w/ #7257 in F @ .750" and 23.50" from Left End

Drill Thru & Counterbore Designations

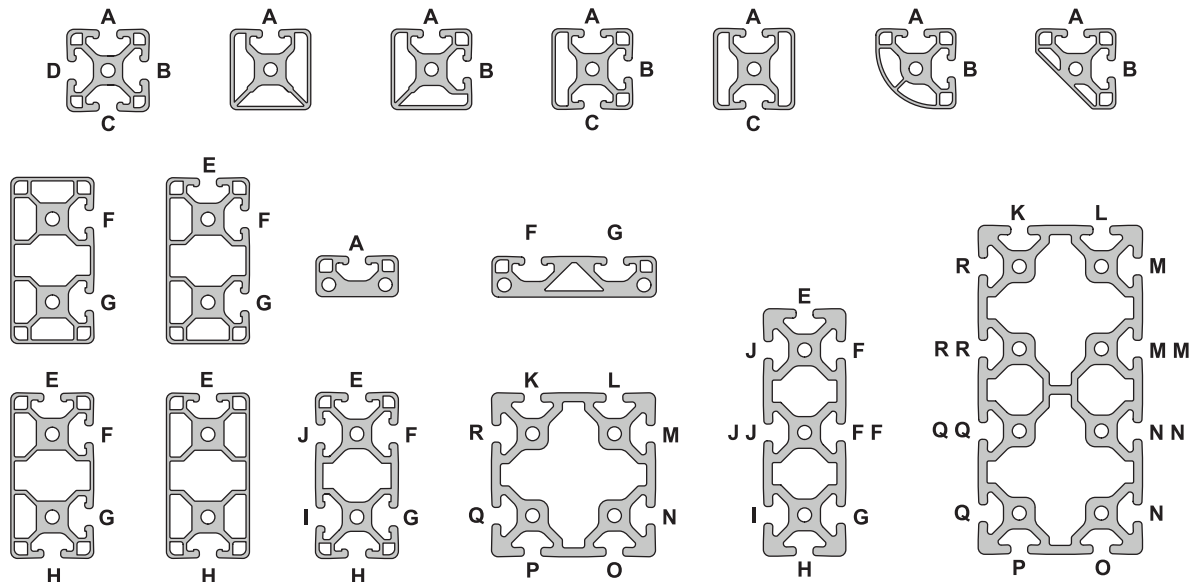

CONTINUE

Predetermined Style Drill Thru & Counterbore

Series	One Hole Style (per T-slot)	Two Hole Style (per T-slot)	Three Hole Style (per T-slot)	Four Hole Style (per T-slot)
10	Style C (.218" Diameter Drill Thru)	Style D (.218" Diameter Drill Thru)	Style H (.218" Diameter Drill Thru)	Style J (.218" Diameter Drill Thru)
15	Style A (.295" Diameter Drill Thru)	Style B (.295" Diameter Drill Thru)	Style F (.295" Diameter Drill Thru)	Style G (.295" Diameter Drill Thru)
25	Style MC (5.50mm Diameter Drill Thru)	Style MD (5.50mm Diameter Drill Thru)	Style MH (5.50mm Diameter Drill Thru)	Style MJ (5.50mm Diameter Drill Thru)
30	Style MR (8.30mm Diameter Drill Thru)	Style MS (8.30mm Diameter Drill Thru)	—	—
40	Style MA (7.50mm Diameter Drill Thru)	Style MB (7.50mm Diameter Drill Thru)	Style MF (7.50mm Diameter Drill Thru)	Style MG (7.50mm Diameter Drill Thru)

Measuring Example (Example uses 15 Series)

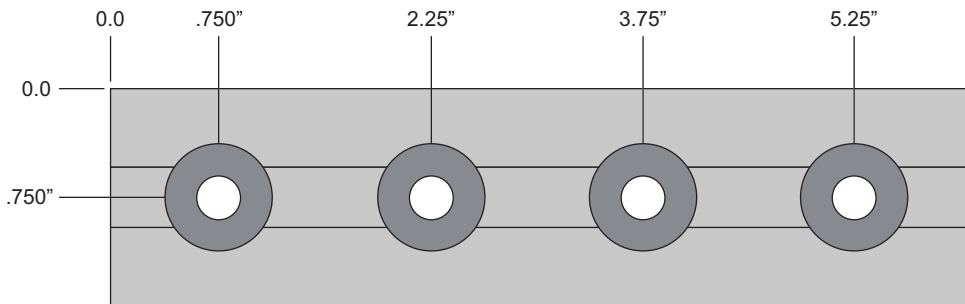

DO NOT CHAIN DIMENSION YOUR DRAWING!

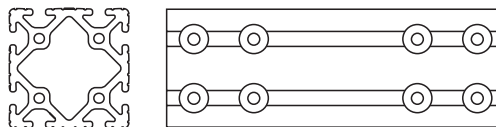

Ordering Example:

(1) 3030 x 40.00" w/ #7257 Style B in M and N left end, #7257 Style B in M and N right end.

Profile Miter Cut

Part Description:

The profile miter cut is used to create custom-angled supports. T-slotted profiles can be miter cut to angles of 15 to 90 degrees or 30 to 90 degrees for select profiles (with the exception of 3060 and 40-8016, which can only be cut to an angle of 45 degrees across the 6.00" (160mm) side. Select structural shapes may also be mitered. See the miter cut worksheet on page 861 for guidelines. **Additional Information:** When ordering this service, designate which profile end (left, right, or both) requires the miter. A drawing is required with this machining service; for project design assistance contact a Design Technician at www.8020.net.

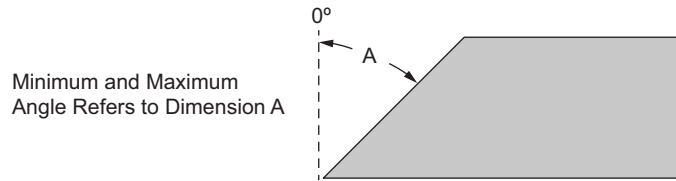

Part No.	Series	Applicable Profiles	Minimum Angle	Maximum Angle
7066	10	1001, 1001-S, 1002, 1002-S, 1003, 1003-S, 1004, 1004-S, 1010, 1010-S, 1012, 1012-S, 1050	0°	75°
7070	10	1020, 1020-S, 2012	0°	75°
7072	10	1030, 1030-S	0°	75°
7071	10	2020, 2020-S	0°	75°
7073	10	2040, 2040-S	0°	60°
7065	15	1501, 1501-LS, 1502, 1502-LS, 1503, 1503-LS, 1504, 1504-LS, 1515, 1515-S, 1515-Lite, 1515-LS, 1515-UL, 1515-ULS, 1517, 1517-LS, 1534-Lite, 1547, 1575	0°	75°
7075	15	1530, 1530-Lite, 1530-LS, 1530-S, 1530-UL, 1530-ULS, 3034-Lite, 3075	0°	60°
7076	15	1545, 1545-S	0°	60°
7085	15	3030, 3030-Lite, 3030-LS, 3030-S	0°	60°
7087	15	3060	0°	45°
20-7065	20	20-2020	0°	75°
20-7075	20	20-2040	0°	60°
20-7085	20	20-4040	0°	60°
25-7066	25	25-2501, 25-2502, 25-2503, 25-2504, 25-2525, 25-2527, 25-2514	0°	75°
25-7070	25	25-2550, 25-5013	0°	60°
25-7071	25	25-5050	0°	60°
25-7072	25	25-2576	0°	60°
25-7073	25	25-5010	0°	45°
30-7065	30	30-3001, 30-3002, 30-3003, 30-3004, 30-3030, 30-3022	0°	75°
30-7075	30	30-3060	0°	60°
30-7085	30	30-6060	0°	60°
40-7065	40	40-4001, 40-4002, 40-4003, 40-4004, 40-4040, 40-4040-Lite, 40-4040-UL, 40-4030-Lite, 40-4045-Lite, 40-4020	0°	75°
40-7075	40	40-4080, 40-4080-Lite, 40-4080-UL, 40-4082-Lite, 40-4083-Lite, 40-4084-Lite, 40-4085-Lite, 40-8020	0°	60°
40-7076	40	40-4012	0°	60°
40-7085	40	40-8080	0°	60°
40-7087	40	40-8016	0°	45°
45-7065	45	45-4545, 45-4545-Lite	0°	75°
45-7075	45	45-4590	0°	60°

Continue to the next page for a Profile Miter Cut Worksheet

CONTINUE

Profile Miter Cut Worksheet

All T-slotted profiles may have miter cuts from 0° to 75°, EXCEPT for 3060 which can only be cut along the long side at 0° to 45° and 40-8016 which can only be cut along the long side at 0° to 45°. Example shown below:

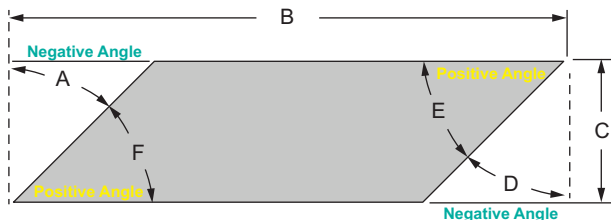

Example:

The following fields are required to complete a custom profile miter cut.

- A = -30° B = 43.18" or 450mm C = 3.00" or 80mm
- D = -45° E = 45° F = 60°

AutoQuoterX™ II always indicates material removed from the profile. (See dimension reference A and D)

Note: Structural shape maximum angle is dependent on profile size

T-Slotted Profile Dimensions Sheet

Be sure to complete all required fields below for a profile miter cut.

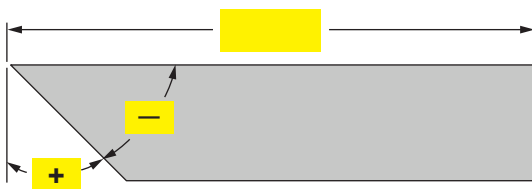
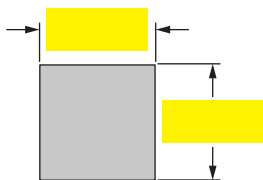

Counterbore Detail

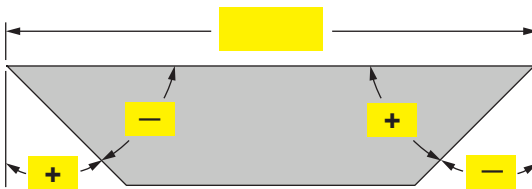
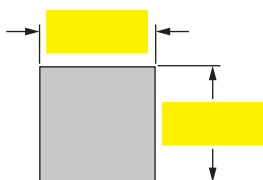
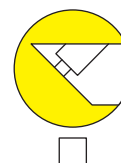

Counterbore Detail

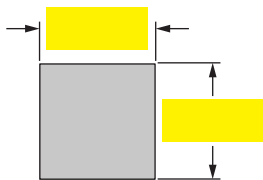
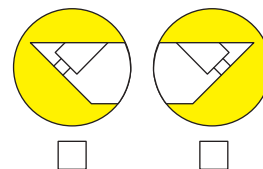

Counterbore Detail

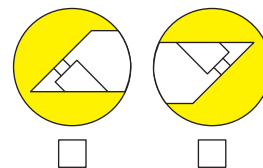

Miter Cut Counterbore

Part Description:

The miter cut counterbore machining service includes both a drill through and counterbore to create custom supports with angles ranging from 30 to 60 degrees. This service is for one end of the profile and includes mounting hardware. Each end receives a counterbore on the mitered face T-slot(s). **Additional Information:** When ordering this service, designate which profile end (left, right, or both) requires the counterbore.

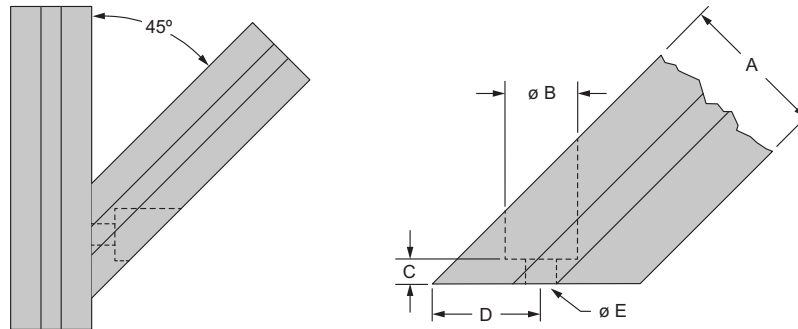

Part No.	Series	Applicable Profiles	A	B	C	D*	E
7083	10	1001, 1001-S, 1002, 1002-S, 1003, 1003-S, 1004, 1004-S, 1010, 1010-S	1.000"	.625"	.250"	.707"	.257"
7079	10	1020, 1020-S					
7074	10	1030, 1030-S					
7082	15	1501, 1501-LS, 1502, 1502-LS, 1503, 1503-LS, 1504, 1504-LS, 1515, 1515-S, 1515-Lite, 1515-LS, 1515-UL, 1515-ULS	1.500"	.750"	.250"	1.061"	.328"
7092	15	1530, 1530-Lite, 1530-LS, 1530-S, 1530-UL, 1530-ULS					
7094	15	1545, 1545-S					
20-7082	20	20-2020	20.00mm	12.70mm	6.30mm	14.14mm	5.30mm
20-7092	20	20-2040					
25-7083	25	25-2501, 25-2502, 25-2503, 25-2504, 25-2525	25.00mm	15.88mm	6.35mm	17.68mm	6.53mm
25-7079	25	25-2550					
25-7074	25	25-2576					
30-7082	30	30-3001, 30-3002, 30-3003, 30-3004, 30-3030	30.00mm	19.05mm	6.35mm	21.21mm	8.30mm
30-7092	30	30-3060					
40-7082	40	40-4001, 40-4002, 40-4003, 40-4004, 40-4040, 40-4040-Lite, 40-4040-UL	40.00mm	19.05mm	6.35mm	28.28mm	8.30mm
40-7092	40	40-4080, 40-4080-Lite, 40-4080-UL, 40-4082-Lite, 40-4083-Lite, 40-4084-Lite, 40-4085-Lite					
40-7094	40	40-4012					
45-7082	45	45-4545, 45-4545-Lite	45.00mm	19.05mm	6.35mm	31.81mm	8.30mm
45-7092	45	45-4590					

*The "D" dimension is for profiles positioned at a 45 degree angle.

Ordering Example: (2) 1515 x 14.00" w/ #7065 @ 45° Left End Per Drawing and #7082 Left End

Included Mounting Hardware

Series	Bolt Part No.	Bolt Description	Qty.	T-Nut Part No.	T-Nut Description	Qty.	Washer Part No.	Qty.
10	3067	1/4-20 x 5/8" Black SHCS	1 to 6	3382	Economy	1 to 6	3258	1 to 6
15	3112	5/16-18 x 3/4" Black SHCS	1 to 6	3278	Economy	1 to 6	3260	1 to 6
20	11-5512	M5 x 12mm Black SHCS	1 to 4	14122	Slide-In	1 to 4	11-6040	1 to 4
25	13-6516	M6 x 16mm Blue SHCS	1 to 6	3859	Economy	1 to 6	13-6045	1 to 6
30	11-8516	M8 x 16mm Black SHCS	1 to 4	13025	Self-Aligning	1 to 4	11-6042	1 to 4
40	13-8518	M8 x 18mm Blue SHCS	1 to 6	3838	Economy	1 to 6	13-6042	1 to 6
45	11-8520	M8 x 20mm Black SHCS	1 to 4	13049	Self-Aligning	1 to 4	11-6042	1 to 4

Part Description:

The profile miter cut with counterbore is used to create 45 degree supports without the use of external flat plates. This service is comprised of the cut and counterbore on both ends and includes mounting hardware. The profile miter cut with counterbore can be used for custom lengths up to 72" (1828.8mm) long. Each end receives a counterbore on the mitered face T-slot(s).

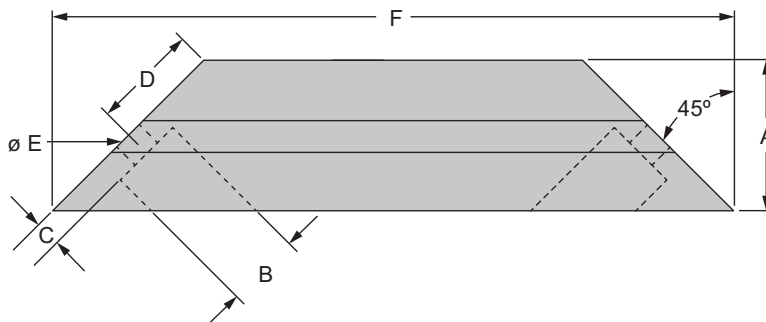

Part No.	Series	Applicable Profiles	A	B	C	D	E	F
7081	10	1001, 1001-S, 1002, 1002-S, 1003, 1003-S, 1004, 1004-S, 1010, 1010-S	1.000"	.625"	.250"	.707"	.257"	Custom
7084	10	1020, 1020-S	1.000"	.625"	.250"	.707"	.257"	
7086	10	1030, 1030-S	1.000"	.625"	.250"	.707"	.257"	
7080	15	1501, 1501-LS, 1502, 1502-LS, 1503, 1503-LS, 1504, 1504-LS, 1515, 1515-S, 1515-Lite, 1515-LS, 1515-UL, 1515-ULS	1.500"	.750"	.250"	1.061"	.328"	
7090	15	1530, 1530-Lite, 1530-LS, 1530-S, 1530-UL, 1530-ULS	1.500"	.750"	.250"	1.061"	.328"	
7093	15	1545, 1545-S	1.500"	.750"	.250"	1.061"	.328"	
20-7080	20	20-2020	20.00mm	12.70mm	6.35mm	14.14mm	5.31mm	
20-7090	20	20-2040	20.00mm	12.70mm	6.35mm	14.14mm	5.31mm	
25-7081	25	25-2501, 25-2502, 25-2503, 25-2504, 25-2525	25.00mm	15.88mm	6.35mm	17.68mm	6.53mm	
25-7084	25	25-2550	25.00mm	15.88mm	6.35mm	17.68mm	6.53mm	
25-7086	25	25-2576	25.00mm	15.88mm	6.35mm	17.68mm	6.53mm	
30-7080	30	30-3001, 30-3002, 30-3003, 30-3004, 30-3030	30.00mm	19.05mm	6.35mm	21.21mm	8.33mm	
30-7090	30	30-3060	30.00mm	19.05mm	6.35mm	21.21mm	8.33mm	
40-7080	40	40-4001, 40-4002, 40-4003, 40-4004, 40-4040, 40-4040-Lite, 40-4040-UL	40.00mm	19.05mm	6.35mm	28.28mm	8.33mm	
40-7090	40	40-4080, 40-4080-Lite, 40-4080-UL, 40-4082-Lite, 40-4083-Lite, 40-4084-Lite, 40-4085-Lite	40.00mm	19.05mm	6.35mm	28.28mm	8.33mm	
40-7093	40	40-4012	40.00mm	19.05mm	6.35mm	28.28mm	8.33mm	
45-7080	45	45-4545, 45-4545-Lite	45.00mm	19.05mm	6.35mm	31.81mm	8.33mm	
45-7090	45	45-4590	45.00mm	19.05mm	6.35mm	31.81mm	8.33mm	

Ordering Example: (2) 1530 x 23.625 w/ #7090 Miter Cut and Counterbore, F = 23.625

Included Mounting Hardware

Series	Bolt Part No.	Bolt Description	Qty.	T-Nut Part No.	T-Nut Description	Qty.	Washer Part No.	Qty.
10	3067	1/4-20 x 5/8" Black SHCS	2 to 6	3382	Economy	2 to 6	3258	2 to 6
15	3112	5/16-18 x 3/4" Black SHCS	2 to 6	3278	Economy	2 to 6	3260	2 to 6
20	11-5512	M5 x 12mm Black SHCS	2 to 4	14122	Slide-In	2 to 4	11-6040	2 to 4
25	13-6516	M6 x 16mm Blue SHCS	2 to 6	3859	Economy	2 to 6	13-6045	2 to 6
30	11-8516	M8 x 16mm Black SHCS	2 to 4	13025	Self-Aligning	2 to 4	11-6042	2 to 4
40	13-8518	M8 x 18mm Blue SHCS	2 to 6	3838	Economy	2 to 6	13-6042	2 to 6
45	11-8520	M8 x 20mm Black SHCS	2 to 4	13049	Self-Aligning	2 to 4	11-6042	2 to 4

Clearance Drill Thru in T-Slot

Part Description:

The clearance drill thru in T-slot is typically used for additional clearance while adding stem casters or leveling feet to a profile. It is a drill through the profile T-slot, as designated in the charts below. **Additional Information:** When ordering this service, designate T-slot position from left end of profile.

Part No.	Series	Service Type	Hole Diameter
7244	10 15	Drill Thru Hole in T-Slot	.257"
7246	10 15 RT		.328"
7248	10 15		.438"
7240	15		.563"
65-7244	25 30 40 45		6.53mm
65-7246	25 30 40 45		8.33mm
65-7248	25 30 40 45		11.13mm
65-7240	30 40 45		14.30mm

Ordering Example: (2) 1530 x 24.00" w/ #7248 in T @ 1.50" and 22.50" from Left End

Clearance Drill Thru in T-Slot Designations

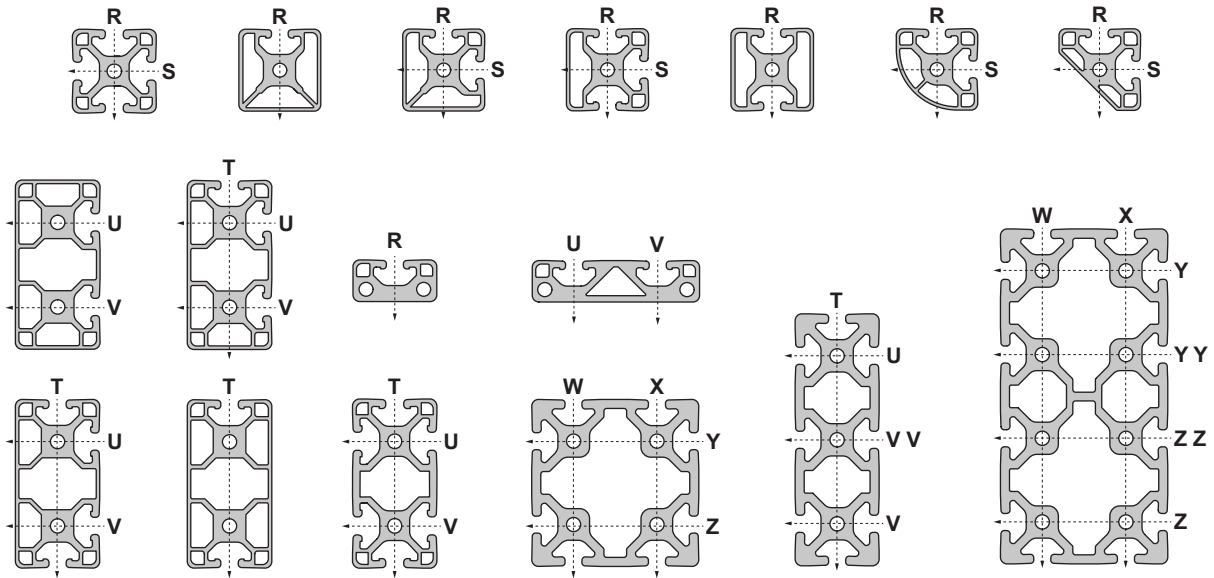

Part Description:

The clearance drill thru between T-slots is typically used for additional clearance while adding stem casters or leveling feet to a profile. It is a drill through the profile wall, as designated in the charts below. **Additional Information:** When ordering this service, designate T-slot position from left end of profile.

Part No.	Series	Service Type	Hole Diameter
7241	10 15	Drill Thru Hole in T-Slot	.257"
7243	10 15		.328"
7245	10 15		.438"
7247	15		.563"
65-7241	25 30 40 45		6.53mm
65-7243	25 30 40 45		8.33mm
65-7245	25 30 40 45		11.13mm
65-7247	30 40 45		14.30mm

Ordering Example: (2) 1530 x 24.00" w/ #7247 between U and V @ 1.50" from Left End

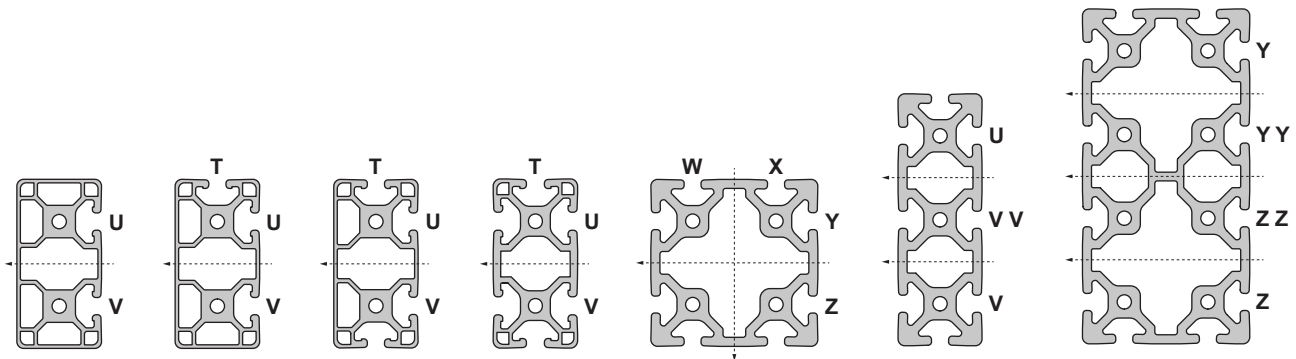
Clearance Drill Thru Between T-Slot Designations

Deluxe Door Handle Profile Milling

Part Description:

The deluxe door handle profile milling service is used to add a deluxe door handle to a T-slot profile. See page 567 for information on deluxe door handles. **Additional Information:** When ordering this service, designate distance from the end of the profile to the centerline (CL).

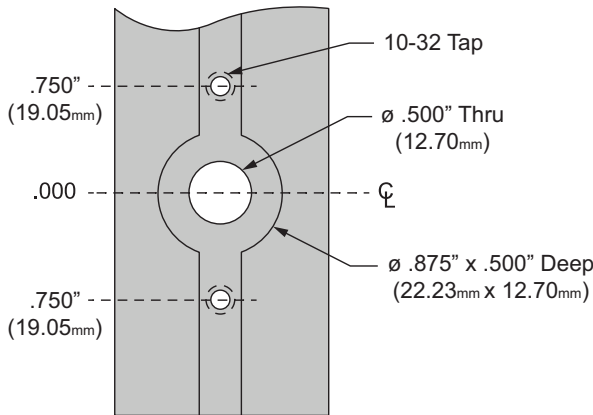

Positioning Example

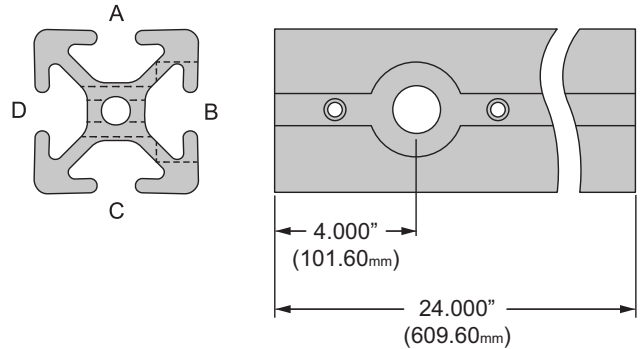

Part No.	Series	Service Type	Bore Size (Depth)
7305	15	Drill Thru Hole for Deluxe Door Handle	ϕ .875" x (.500")
65-7305	40		ϕ 22.23mm x (12.70mm)

Ordering Example: (1) 1515 x 24.00" w/ #7305 in B @ 4.00" from left end.

Deluxe Door Handle Machining Designations

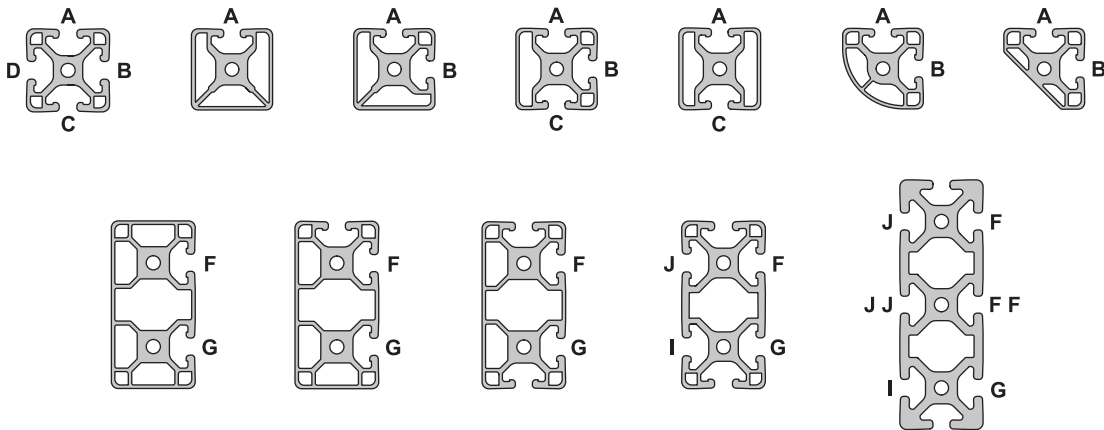

Part Description:

The furniture style handle profile milling service is used to add a furniture style door handle to a T-slot profile. See pages 569-570 for information on furniture style handles. **Additional Information:** When ordering this service, designate distance from the end of the profile to the centerline (CL).

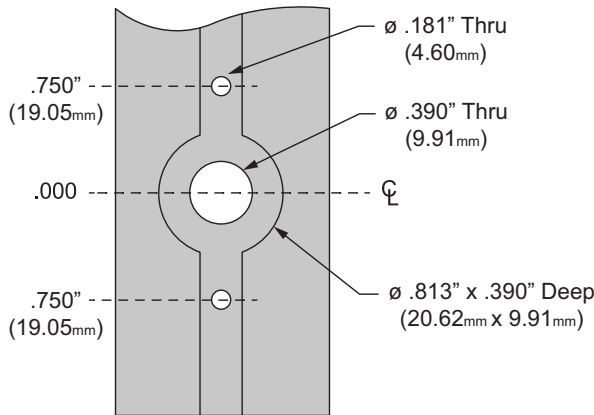

Positioning Example

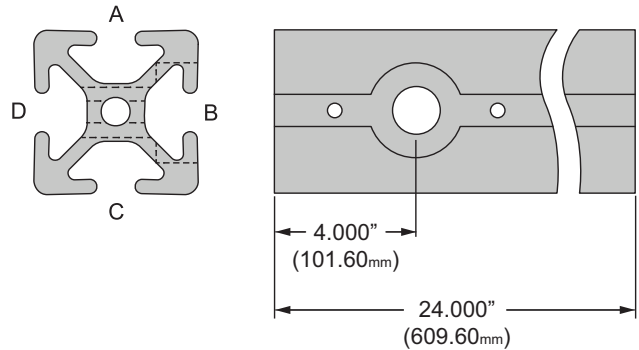

Part No.	Series	Service Type	Bore Size (Depth)
7315	10 15	Drill Thru Hole for Furniture Style Handle	$\varnothing .812'' \times (.390'')$
65-7315	25 40		$\varnothing 20.62\text{mm} \times (9.91\text{mm})$

Ordering Example: (1) 1515 x 24.00" w/ #7315 in B @ 4.00" from left end.

Furniture Style Handle Machining Designations

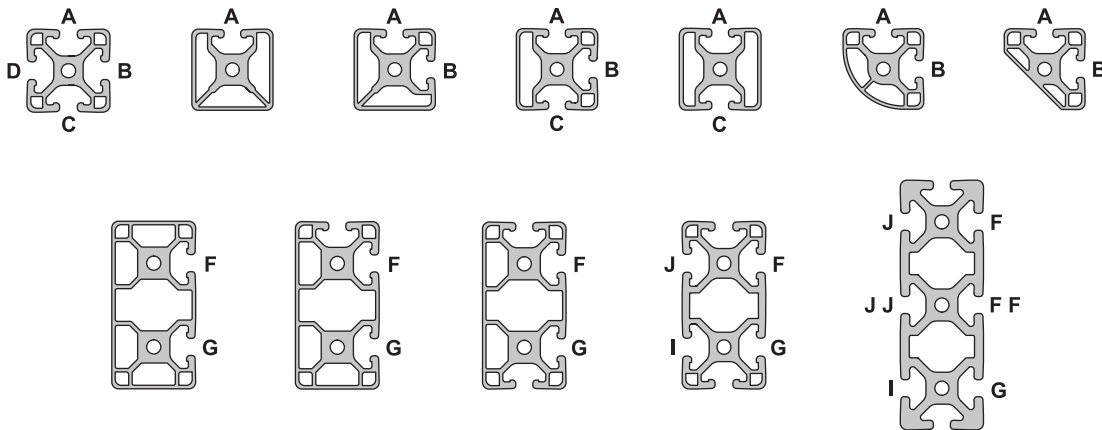

Miter Connector Profile Milling

Part Description:

The miter connector profile milling service allows a miter connector face to be flush with the profile surface and is required when using this connector for a profile connection. See page 221 for information on the miter connector.

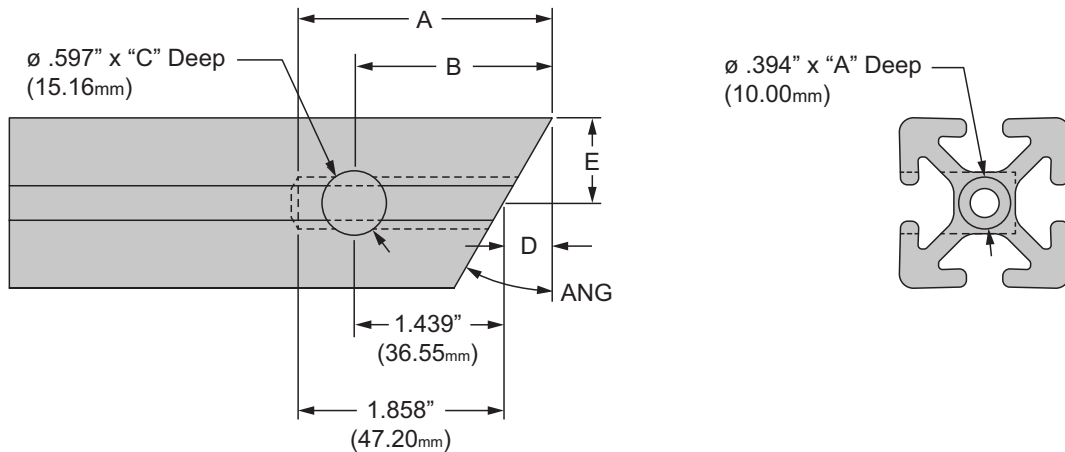

Miter Connector Profile Milling																
Bar Cut Angle (0-45):	ANG	7.5°			15°			22.5°			30°			45°		
Compatible Series:	---	15	40	45	15	40	45	15	40	45	15	40	45	15	40	45
ø.394 (10mm) Drill Depth:	A	1.957"	49.83mm	50.16mm	2.059"	52.55mm	53.22mm	2.169"	55.48mm	56.51mm	2.291"	58.74mm	60.18mm	2.608"	67.19mm	69.69mm
ø.597 (15.16mm) C-bore from Miter Tip:	B	1.538"	39.18mm	39.51mm	1.640"	41.91mm	42.58mm	1.750"	44.84mm	45.87mm	1.872"	48.10mm	49.54mm	2.189"	56.55mm	59.05mm
Counterbore Depth:	C	1.036"	27.25mm	29.77mm	1.036"	27.25mm	29.77mm	1.036"	27.25mm	29.77mm	1.036"	27.25mm	29.77mm	1.036"	27.25mm	29.77mm
Miter Offset:	D	.099"	2.63mm	2.96mm	.201"	5.36mm	6.03mm	.311"	8.28mm	9.32mm	.433"	11.55mm	12.99mm	.750"	20.00mm	22.50mm
Center of Bar:	E	.750"	20.00mm	22.50mm	.750"	20.00mm	22.50mm	.750"	20.00mm	22.50mm	.750"	20.00mm	22.50mm	.750"	20.00mm	22.50mm

Part No.	Series	Service Type
7110	15	Counterbore for Miter Connector
40-7110	40	
45-7110	45	

Miter Connector Machining Designations

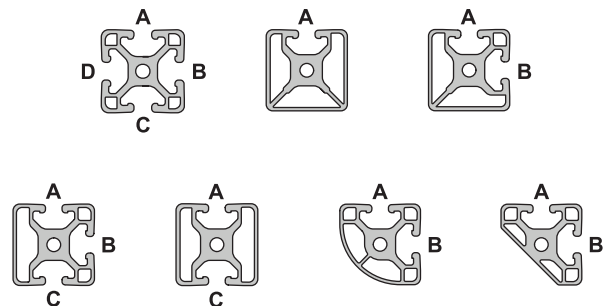

MACHINING SERVICES

Part Description:

The economy T-nut clearance profile milling service allows placement of an economy T-nut into a T-slot profile when the ends are captivated. See the hardware section beginning on page 362 for information on economy T-nuts. **Additional Information:** When ordering this service, specify the distance from the end of the profile to the centerline (CL) and designate T-slot location that requires the service.

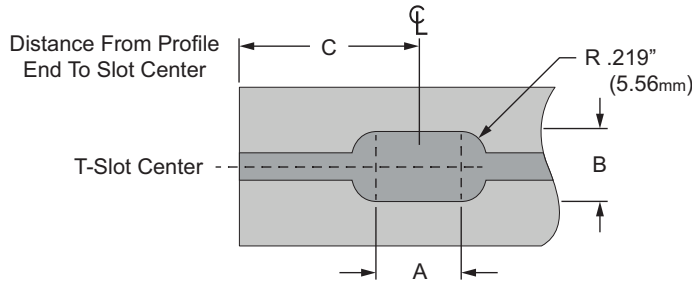

Part No.	Series	Compatible T-Nut Type	Slot Length "A"	Slot Width "B"	Minimum Distance "C"	Tolerance
7098	10	Single	.625"	.506"	.532"	Slot Length +/- .030" Slot Width +/- .010"
7101	10	Double	1.625"	.506"	1.032"	
7103	10	Triple	2.203"	.506"	1.321"	
7099	15	Single	.763"	.700"	.601"	
7102	15	Double	2.638"	.700"	1.538"	
7104	15	Triple	3.198"	.700"	1.818"	
25-7098	25	Single	15.88mm	12.85mm	13.51mm	Slot Length +/- .76mm Slot Width +/- .25mm
25-7101	25	Double	41.28mm	12.85mm	26.21mm	
40-7099	40	Single	19.38mm	17.78mm	15.27mm	
40-7102	40	Double	67.00mm	17.78mm	39.07mm	

Ordering Example: (2) 1010 x 18.000 w/ #7098 in A @ 3.00 and 15.00 from Left End

Economy T-Nut Clearance Designations

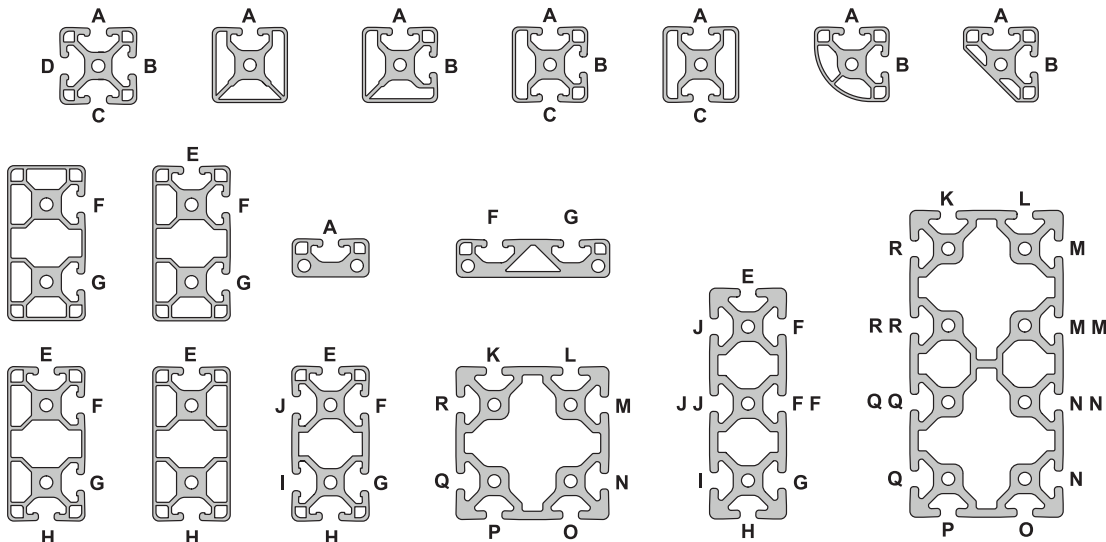

Central Connector Profile Milling

Part Description:

The central connector profile milling service consists of both a drill through the profile end and a T-slot counterbore. This machining service enables the use of a central connector (page 223 for information on central connectors). **Additional Information:** When ordering this milling service, designate profile end (left, right or both) and T-slot for the counterbore.

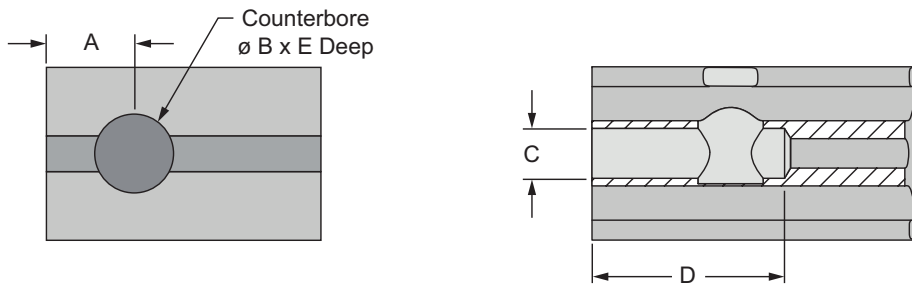

Part No.	Series	Service Type	A	B	C	D	E
7058	15	15 Series Profile Milling for Central Connector	1.260"	.597"	.453"	1.750"	1.025"
40-7058	40	40 Series Profile Milling for Central Connector	32.00mm	15.16mm	11.51mm	44.45mm	26.97mm
45-7058	45	45 Series Profile Milling for Central Connector	22.50mm	17.12mm	—	—	32.64mm

Central Connector Machining Designations

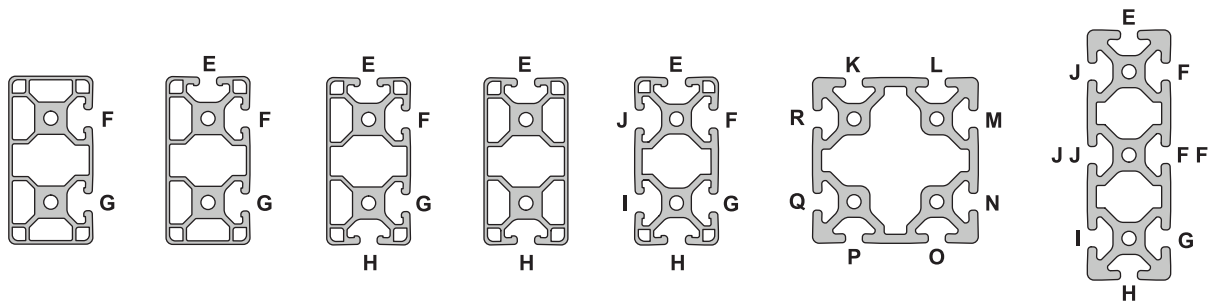
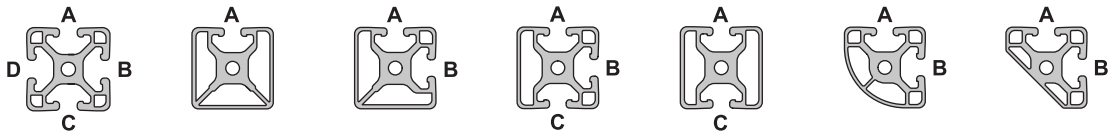

Part Description:

The manifold access profile milling service consists of a drill through one wall of a T-slot profile to provide access to the center cavity for use with pressure manifolds. See the manifolds section beginning on page 749 for information on pressure manifolds. **Additional Information:** When ordering, designate distance from the left end of the profile. Reference the hole location by specifying “between” T-slot designations. See below for T-slot designations.

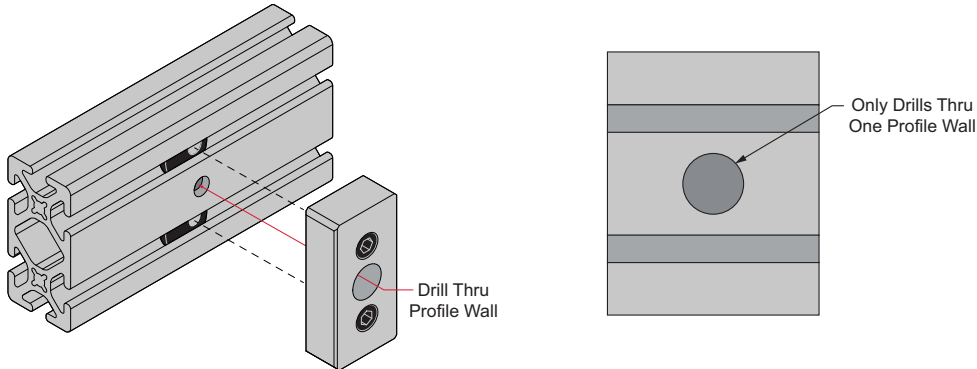

Part No.	Series	Service Type	Hole Diameter
7062	10	Drill Thru One Profile Wall	.327"
7068	15		.374"
25-7062	25		8.30mm
40-7068	40		9.50mm

Ordering Example: 1530: (1) @48.25" w/ #7068 btwn F and G @ 12.00" and 36.25" from left end.

Manifold Access Drill Thru Designations

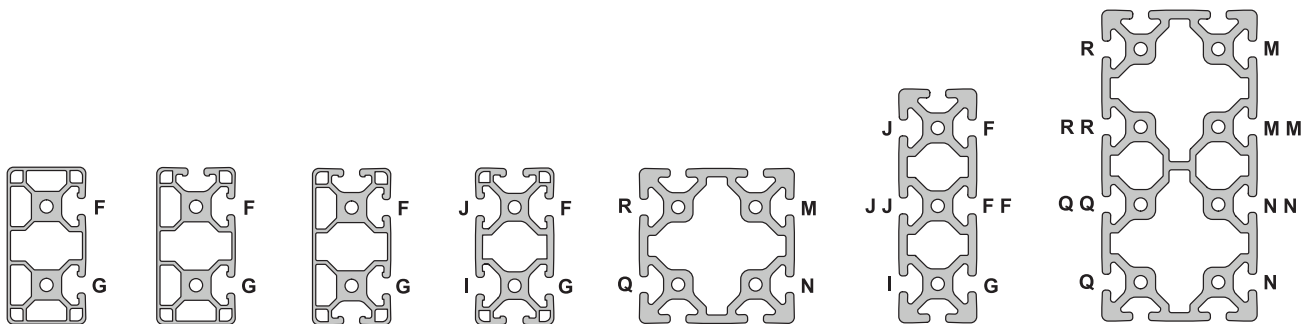

Bolt Connector Profile Milling

Part Description:

The bolt connector profile milling service provides clearance for use of a bolt connector with T-slot profiles. See page 224 for information on bolt connectors. **Additional Information:** When ordering this milling service, designate profile end (left, right, or both) and T-slot for the clearance hole.

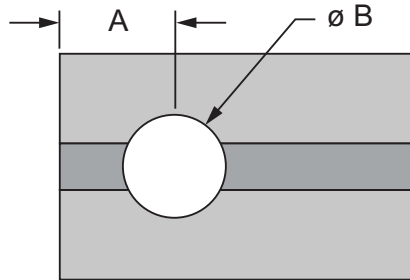

Part No.	Series	Service Type	Bolt Connector	A	B
30-7034	30	30 Series Profile Milling for Bolt Connector (30.00mm only)	13189	16.50mm	8.30mm
45-7034	45	45 Series Profile Milling for Bolt Connector (45.00mm)	13190	23.70mm	17.02mm
45-7037	45	45 Series Profile Milling for Bolt Connector (90.00mm)	13192	23.70mm	17.02mm

Ordering Example: (2) 45-4590 x 908.0mm w/45-7037 in slot R both ends.

Bolt Connector Machining Designations

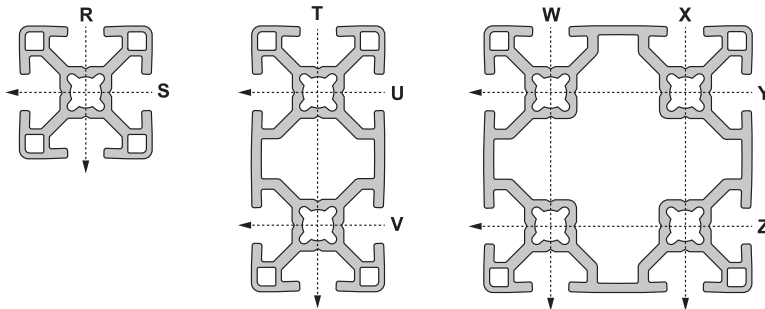

Brake Holes for Linear Bearings

Part No.	Series	Hole Diameter	Part No.	Series	Hole Diameter
7401	10	.265"	7400	15	.344"

Ordering Example: (1) 6724 w/ #7401 @ LN, LR, LQ and LU

Fractional Part No.	Series	Hole Locations	X	X*	Y	Z
6715 / 6716*	10	LA	.937"	1.000"	—	1.562"
		LB	.937"	1.000"	.812"	—
		LC	.937"	1.000"	—	1.562"
6716*	10	LD	—	3.000"	—	1.562"
		LE	—	3.000"	.812"	—
		LF	—	3.000"	—	1.562"
6725 / 6726*	10	LG	.937"	1.000"	—	.812"
		LH	.937"	1.000"	1.469"	—
		LI	.937"	1.000"	—	.812"
6726*	10	LJ	—	3.000"	—	.812"
		LK	—	3.000"	1.469"	—
		LM	—	3.000"	—	.812"
6723 / 6724*	10	LN	.937"	1.000"	—	.812"
		LO	.937"	1.000"	2.469"	—
		LP	.937"	1.000"	1.469"	—
		LQ	.937"	1.000"	—	.812"
6724*	10	LR	—	3.000"	—	.812"
		LS	—	3.000"	2.469"	—
		LT	—	3.000"	1.469"	—
		LU	—	3.000"	—	.812"
6815 / 6830 6816* / 6831*	15	LA	1.406"	1.500"	—	2.125"
		LB	1.406"	1.500"	1.250"	—
		LC	1.406"	1.500"	—	2.125"
6816* / 6831*	15	LD	—	4.500"	—	2.125"
		LE	—	4.500"	1.250"	—
		LF	—	4.500"	—	2.125"
6825 / 6835 6826* / 6836*	15	LG	1.406"	1.500"	—	1.250"
		LH	1.406"	1.500"	2.000"	—
		LI	1.406"	1.500"	—	1.250"
6826* / 6836*	15	LJ	—	4.500"	—	1.250"
		LK	—	4.500"	2.000"	—
		LM	—	4.500"	—	1.250"
6823 / 6833 6824* / 6834*	15	LN	1.406"	1.500"	—	1.250"
		LO	1.406"	1.500"	3.500"	—
		LP	1.406"	1.500"	2.000"	—
		LQ	1.406"	1.500"	—	1.250"
6824* / 6834*	15	LR	—	4.500"	—	1.250"
		LS	—	4.500"	3.500"	—
		LT	—	4.500"	2.000"	—
		LU	—	4.500"	—	1.250"

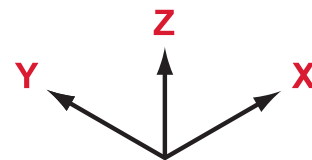
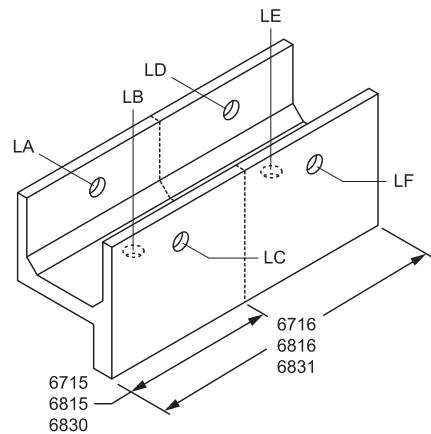
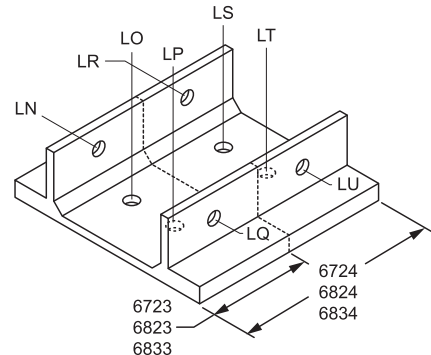
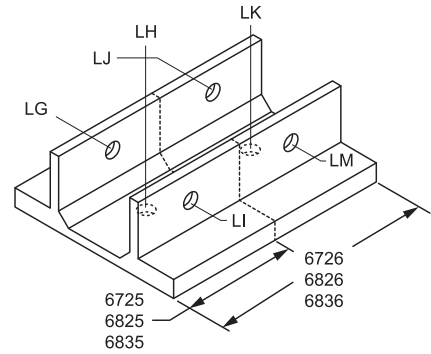

MACHINING SERVICES

Continue to 874 for metric brake holes for linear bearings

CONTINUE →

Brake Holes for Linear Bearings (Continued)



Part No.	Series	Hole Diameter	Part No.	Series	Hole Diameter
25-7401	25	6.73mm	40-7400	40	8.73mm

Ordering Example: (1) 25-6724 w/ #25-7401 @ LN, LR, LQ and LU

Metric Part No.	Series	Hole Locations	X	X*	Y	Z
25-6715 / 25-6716*	25	LA	23.50mm	25.00mm	—	39.07mm
		LB	23.50mm	25.00mm	20.56mm	—
		LC	23.50mm	25.00mm	—	39.07mm
25-6716*	25	LD	—	75.00mm	—	39.07mm
		LE	—	75.00mm	20.56mm	—
		LF	—	75.00mm	—	39.07mm
25-6725 / 25-6726*	25	LG	23.50mm	25.00mm	—	20.52mm
		LH	23.50mm	25.00mm	37.05mm	—
		LI	23.50mm	25.00mm	—	20.52mm
25-6726*	25	LJ	—	75.00mm	—	20.52mm
		LK	—	75.00mm	37.05mm	—
		LM	—	75.00mm	—	20.52mm
25-6723 / 25-6724*	25	LN	23.50mm	25.00mm	—	20.52mm
		LO	23.50mm	25.00mm	62.13mm	—
		LP	23.50mm	25.00mm	37.13mm	—
25-6724*	25	LQ	23.50mm	25.00mm	—	20.52mm
		LR	—	75.00mm	—	20.52mm
		LS	—	75.00mm	62.13mm	—
40-6815 / 40-6830 40-6816* / 40-6831*	40	LA	37.50mm	40.00mm	—	54.38mm
		LB	37.50mm	40.00mm	32.57mm	—
		LC	37.50mm	40.00mm	—	54.38mm
40-6816* / 40-6831*	40	LD	—	120.00mm	—	54.38mm
		LE	—	120.00mm	32.57mm	—
		LF	—	120.00mm	—	54.38mm
40-6825 / 40-6835 40-6826* / 40-6836*	40	LG	37.50mm	40.00mm	—	32.57mm
		LH	37.50mm	40.00mm	51.56mm	—
		LI	37.50mm	40.00mm	—	32.57mm
40-6826* / 40-6836*	40	LJ	—	120.00mm	—	32.57mm
		LK	—	120.00mm	51.56mm	—
		LM	—	120.00mm	—	32.57mm
40-6823 / 40-6833 40-6824* / 40-6834*	40	LN	37.50mm	40.00mm	—	32.57mm
		LO	37.50mm	40.00mm	91.65mm	—
		LP	37.50mm	40.00mm	51.56mm	—
40-6824* / 40-6834*	40	LQ	37.50mm	40.00mm	—	32.57mm
		LR	—	120.00mm	—	32.57mm
		LS	—	120.00mm	91.65mm	—
	40	LT	—	120.00mm	51.56mm	—
		LU	—	120.00mm	—	32.57mm

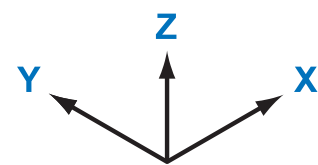
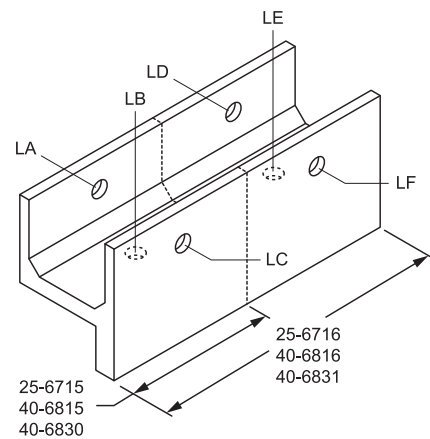
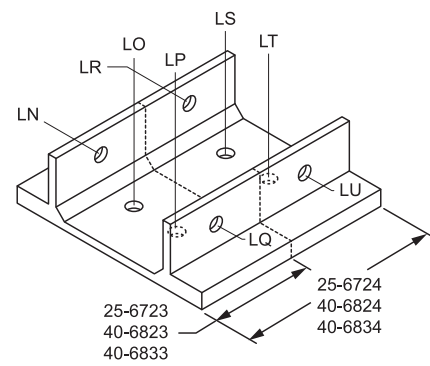
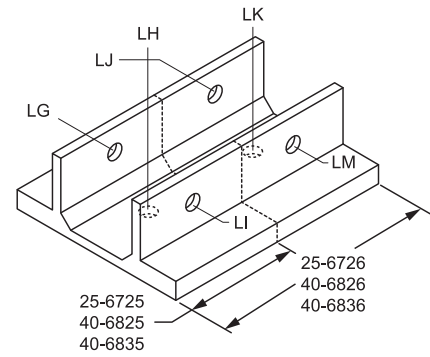

Refer to page 873 for fractional brake holes for linear bearings

MACHINING SERVICES

80/20[®] Inc. 45 Degree Flange Milling / Connector Rod End Tap

45 Degree Flange Milling

The 45 degree flange milling service allows two Quick Frame profile flanges to intersect at 90 degrees without interference. **Additional Information:** This service is for two ends. If one end is desired specify left or right end.

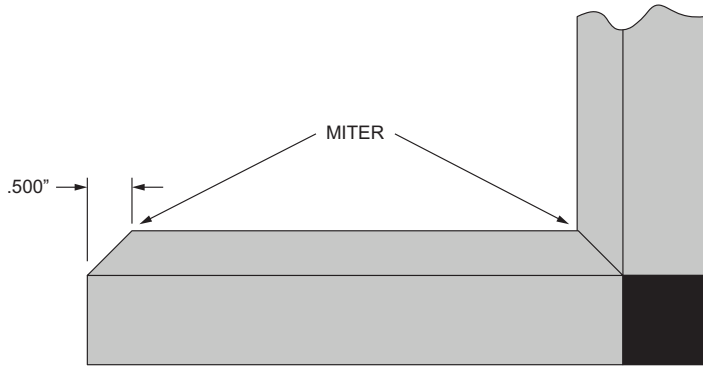

Part No.	Series	Service Type
7300	QF	45 Degree Flange Milling Service for Quick Frame Location A, B or C only
7301	QF	45 Degree Flange Milling Service for Quick Frame Location A and B
7302	QF	45 Degree Flange Milling Service for Quick Frame Location A and C

Ordering Example: (2) #9010 x 22.00" w/ #7300 on A per drawing.

45 Degree Flange Machining Designations

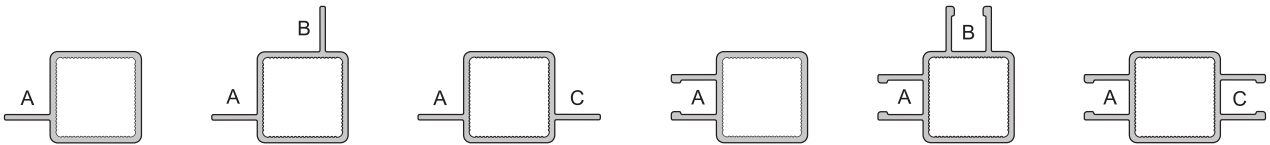

Connector Rod End Tap

The connector rod end tap machining service is used to add threads to the end of a connector rod. This enables the insertion of a bolt to mount accessories. **Additional Information:** When ordering this end tap, designate which end (left, right or both) requires the tap. See page 762 for more information on connector rods.

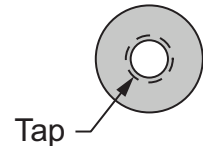

Part No.	Series	Tap Size (Min. Depth)	Taps Per End	Profile Part No.
7105	F RT	5/16-18 (1.25")	1	9820
7106	F RT	M8 x 1.25" (31.75mm)		

Cut Plastic Panel to Size / Aluminum Plate to Size / Shear Wire Mesh to Size

Part Description:

The cut panel to size machining service is used to create custom plastic, mesh, or aluminum plates and panels. It has a tolerance of plus or minus .060" (1.52mm) and there are options available to accommodate different thicknesses and required lengths.

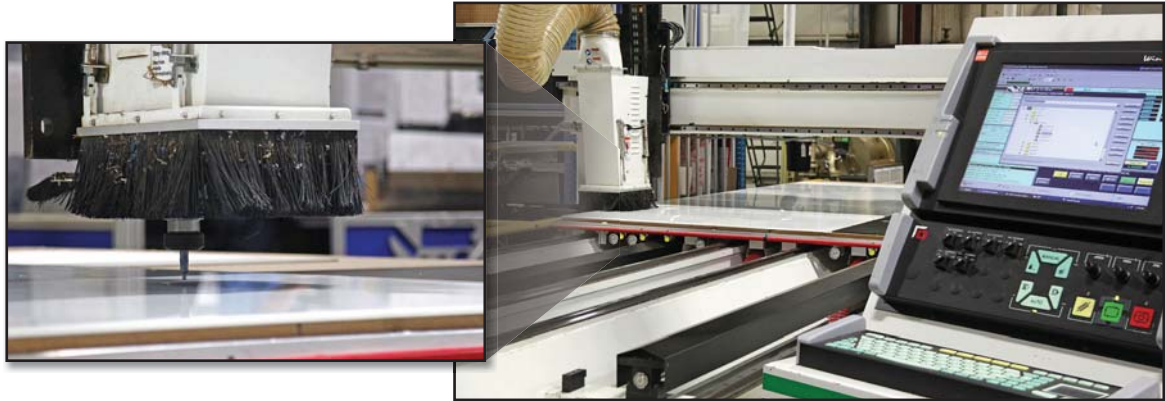

Cut Plastic Panel or Aluminum Plate to Size

Panel Part No.	Aluminum Part No.	Series	Service Type	Cut Tolerance
7150	7167	F	Cut Plastic Panel or Aluminum Plate ALL Sides ≤ 48" for Panels Up To .250" Thick	+/- .060"
7155	7168	F	Cut Plastic Panel or Aluminum Plate ANY Side > 48" for Panels Up To .250" Thick	
7151	7169	F	Cut Plastic Panel or Aluminum Plate ALL Sides ≤ 48" for Panels Thicker Than .250"	
7153	7170	F	Cut Plastic Panel or Aluminum Plate ANY Side > 48" for Panels Thicker Than .250"	
65-7150	65-7167	M	Cut Plastic Panel or Aluminum Plate ALL Sides ≤ 1220mm for Panels Up To 6mm Thick	+/- 1.52mm
65-7155	65-7168	M	Cut Plastic Panel or Aluminum Plate ANY Side > 1220mm for Panels Up To 6mm Thick	
65-7151	65-7169	M	Cut Plastic Panel or Aluminum Plate ALL Sides ≤ 1220mm for Panels Thicker Than 6mm	
65-7153	65-7170	M	Cut Plastic Panel or Aluminum Plate ANY Side > 1220mm for Panels Thicker Than 6mm	



Shear Wire Mesh to Size

Part No.	Series	Service Type	Cut Tolerance
7095	F	Shear Wire Mesh ALL Sides ≤ 48"	+/- .060"
7100	F	Shear Wire Mesh ANY Side > 48"	
65-7095	M	Shear Wire Mesh ALL Sides ≤ 1220mm	+/- 1.52mm
65-7100	M	Shear Wire Mesh ANY Side > 1220mm	

Part Description:

The T-slot access routing for thick plastic panel and aluminum plate is used to enable a thicker panel or plate to be recessed within a T-slot with panel gasket. This service is for plastic panel or aluminum plate thicknesses of .375" (9.53mm) or .500" (12.7mm).

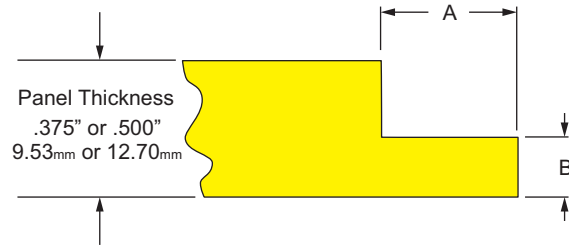
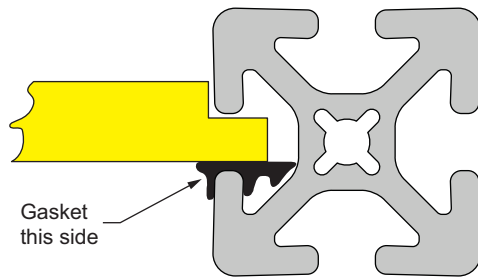

Panel Part No.	Aluminum Part No.	Series	Service Type	Description	A	B	Cut Tolerance
7530	7206	10	Routing Plastic Panel or Aluminum Plate ALL Sides $\leq 48^\circ$	To Mount 3/8" or 1/2" Plastic Panels or Aluminum Plate	.335"	.177"	A +/- .015" B +/- .010"
7531	7207	10	Routing Plastic Panel or Aluminum Plate ANY Side $> 48^\circ$.458"	.236"	
7532	7208	15	Routing Plastic Panel or Aluminum Plate ALL Sides $\leq 48^\circ$		9.00mm	4.50mm	A +/- .38mm B +/- .25mm
7533	7209	15	Routing Plastic Panel or Aluminum Plate ANY Side $> 48^\circ$		9.50mm	6.00mm	
25-7530	25-7206	25	Routing Plastic Panel or Aluminum Plate ALL Sides $\leq 1220\text{mm}$	To Mount 9.53mm or 12.70mm Plastic Panels or Aluminum Plate	13.00mm	6.00mm	
25-7531	25-7207	25	Routing Plastic Panel or Aluminum Plate ANY Side $> 1220\text{mm}$		14.00mm	6.00mm	
30-7532	30-7208	30	Routing Plastic Panel or Aluminum Plate ALL Sides $\leq 1220\text{mm}$				
30-7533	30-7209	30	Routing Plastic Panel or Aluminum Plate ANY Side $> 1220\text{mm}$				
40-7532	40-7208	40	Routing Plastic Panel or Aluminum Plate ALL Sides $\leq 1220\text{mm}$				
40-7533	40-7209	40	Routing Plastic Panel or Aluminum Plate ANY Side $> 1220\text{mm}$				
45-7534	---	45	Routing Plastic Panel or Aluminum Plate ALL Sides $\leq 1220\text{mm}$				
45-7535	---	45	Routing Plastic Panel or Aluminum Plate ANY Side $> 1220\text{mm}$				

Edge Radius

Part Description:

The edge radius is used to round off either both or one sharp edge of highly visible panels. When both edges are rounded the radius will be equal to the panel thickness; when one edge is rounded the radius will equal to half the panel thickness with a minimum panel thickness of .250" (6.35mm). The edge radius can also help ease the insertion of panels into gasket. Edge radius services are for all four panel sides. Less than all four sides requires a drawing designating which sides receive the edge radius service.



Full Edge Radius

Panels Part No.	Aluminum Part No.	Series	Service Type	Radius Tolerance
7500	7221	F	Full Edge Radius Plastic Panel or Aluminum Plate ALL Sides Less Than Or Equal To 48"	+/- .040"
7501	7222	F	Full Edge Radius Plastic Panel or Aluminum Plate ANY Side Greater Than 48"	
65-7500	65-7221	M	Full Edge Radius Plastic Panel or Aluminum Plate ALL Sides Less Than Or Equal To 1220mm	+/- 1.02mm
65-7501	65-7222	M	Full Edge Radius Plastic Panel or Aluminum Plate ANY Side Greater Than 1220mm	

*Minimum Panel Thickness is .125" (3.18mm). Maximum Panel Thickness is .500" (12.7mm).

Top Edge Radius

Panels Part No.	Aluminum Part No.	Series	Service Type	Radius Tolerance
7540	7542	F	Top Edge Radius Plastic Panel or Aluminum Plate ALL Sides Less Than Or Equal To 48"	+/- .040"
7541	7543	F	Top Edge Radius Plastic Panel or Aluminum Plate ANY Side Greater Than 48"	
65-7540	65-7542	M	Top Edge Radius Plastic Panel or Aluminum Plate ALL Sides Less Than Or Equal To 1220mm	+/- 1.02mm
65-7541	65-7543	M	Top Edge Radius Plastic Panel or Aluminum Plate ANY Side Greater Than 1220mm	

*Minimum Panel Thickness is .125" (3.18mm). Maximum Panel Thickness is .750" (19.05mm).



Part Description:

The corner radius is used to round corners on plastic panels or aluminum plates. The maximum radius is 3.00" (76.20mm). This service is commonly used for tabletops and workstations.

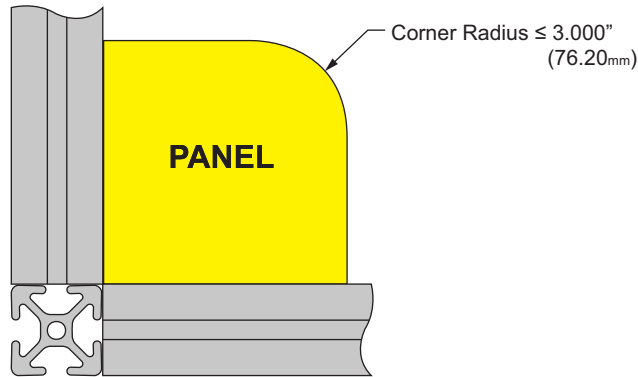

Panel Part No.	Aluminum Part No.	Series	Service Type	Tolerance
7179	7176	F	Corner Radius Plastic Panel or Aluminum Plate RADIUS ≤ 3.000" Up To .250" Thick	+/- .060"
7187	7195	F	Corner Radius Plastic Panel or Aluminum Plate RADIUS ≤ 3.000" Thicker Than .250"	
65-7179	65-7176	M	Corner Radius Plastic Panel or Aluminum Plate RADIUS ≤ 76.20mm Up To 6mm Thick	+/- 1.52mm
65-7187	65-7195	M	Corner Radius Plastic Panel or Aluminum Plate RADIUS ≤ 76.20mm Thicker Than 6mm	

Ordering Example:

2609 (1) @ (AD) 18.000" x (AB) 18.000"
w/ 7179 on Corner D 2.50" R

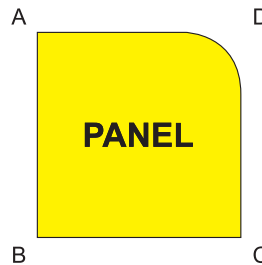

Profile Corner Clearance Notch

Part Description:

The profile corner clearance notch is used to clear a profile corner for perpendicularly mounted T-slot profiles when the panel will mount inside the T-slot. This notch is used on mesh, plastic panels, and aluminum up to .250" (6.35mm) thick.

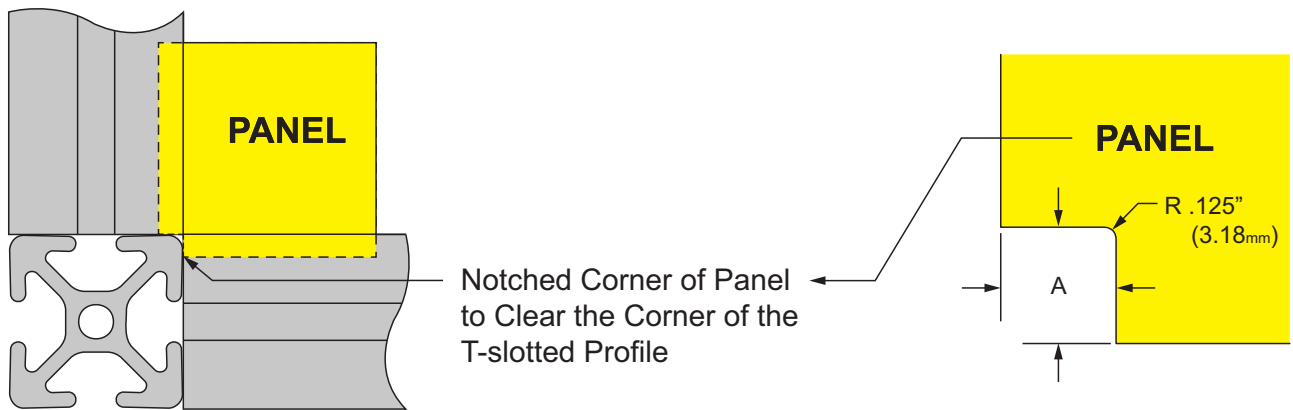

Panel & Wire Part No.	Aluminum Part No.	Series	Service Type	A	Cut Tolerance
7504	7202	10	Corner Notch	.312"	+/- .060"
7505	7203	15		.440"	
20-7504	20-7202	20		6.00mm	+/- 1.52mm
25-7504	25-7202	25		7.90mm	
30-7505	30-7203	30		9.00mm	
40-7505	40-7203	40		11.20mm	
45-7506	---	45		14.00mm	

Ordering Example:

2609 (1) @ (AD) 18.000" x (AB) 18.000"
w/ 7505 Horizontal on Corner B

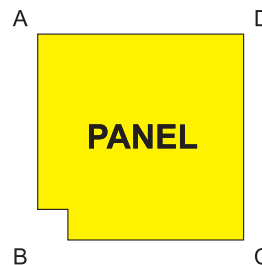

Part Description:

The full profile corner clearance notch is used to clear a T-slot profile when profiles are mounted perpendicularly. This notch is used on mesh, plastic panels, and aluminum up to .250" (6.35mm) thick.

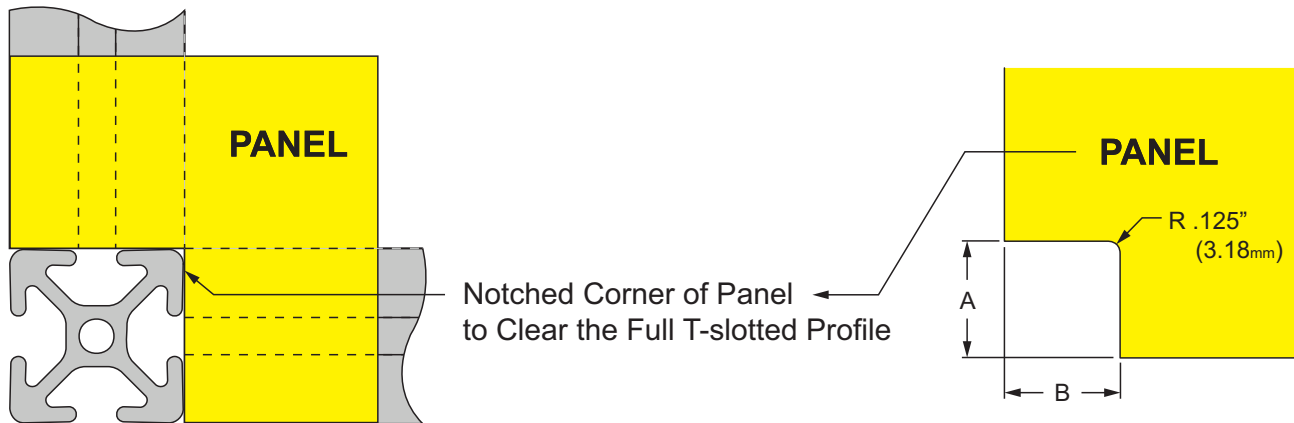

Panel & Wire Part No.	Aluminum Part No.	Series	Applicable Profiles	A	B	Cut Tolerance
7597	7231	10	1001, 1001-S, 1002, 1002-S, 1003, 1003-S, 1004, 1004-S, 1010, 1010-S, 1012, 1012-S	1.060"	1.060"	+/- .060"
7598	7232	10	1020, 1020-S	1.060"	2.060"	
7599	7233	10	2020, 2020-S	2.060"	2.060"	
7600	7234	15	1501, 1501-LS, 1502, 1502-LS, 1503, 1503-LS, 1504, 1504-LS, 1515, 1515-S, 1515-Lite, 1515-LS, 1515-UL, 1515-ULS, 1517, 1517-LS, 1547	1.560"	1.560"	
7601	7235	15	1530, 1530-Lite, 1530-LS, 1530-S, 1530-UL, 1530-ULS	1.560"	3.060"	
7602	7236	15	3030, 3030-Lite, 3030-S, 3030-LS	3.060"	3.060"	
20-7597	20-7231	20	20-2020	21.52mm	21.52mm	+/- 1.52mm
25-7597	25-7231	25	25-2501, 25-2502, 25-2503, 25-2504, 25-2525, 25-2527	26.52mm	26.52mm	
25-7598	25-7232	25	25-2550	26.52mm	51.52mm	
25-7599	25-7233	25	25-5050	51.52mm	51.52mm	
30-7600	30-7234	30	30-3001, 30-3002, 30-3003, 30-3004, 30-3030, 30-3022	31.52mm	31.52mm	
40-7600	40-7234	40	40-4001, 40-4002, 40-4003, 40-4004, 40-4030-Lite, 40-4040, 40-4040-Lite, 40-4040-UL, 45-4045-Lite	41.52mm	41.52mm	
40-7601	40-7235	40	40-4080, 40-4080-Lite	41.52mm	81.52mm	
40-7602	40-7236	40	40-8080	81.52mm	81.52mm	
45-7603	45-7237	45	45-4545, 45-4545-Lite	46.52mm	46.52mm	
45-7604	45-7233	45	45-4590	46.52mm	91.52mm	
45-7605	45-7239	45	45-9090	91.52mm	91.52mm	

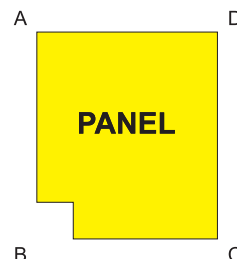
**Ordering Example:**

2609 (1) @ (AD) 18.000" x (AB) 22.000"
w/ 7600 on Corner B

End Fastener Clearance Notch

Part Description:

The end fastener clearance notch is used to clear an end fastener tab when a panel will mount inside a T-slot. This notch is used on mesh, plastic panels and aluminum up to .250" (6.35mm) thick. See pages 217-219 for information on end fasteners.

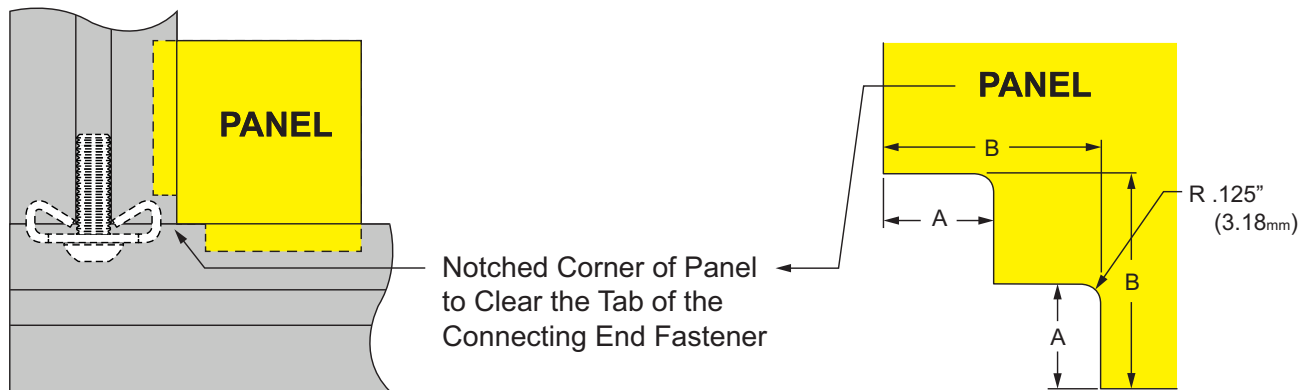

Panel & Wire Part No.	Aluminum Part No.	Series	Service Type	A	B	Cut Tolerance
7502	7211	10	Corner Notch	.250"	.650"	+/- .060"
7503	7214	15		.340"	.650"	
20-7512	20-7211	20		5.10mm	13.50mm	+/- 1.52mm
25-7502	25-7211	25		6.40mm	16.50mm	
30-7053	30-7214	30		8.60mm	14.50mm	
40-7503	40-7214	40		8.60mm	16.50mm	

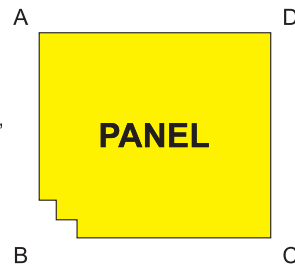

Ordering Example:

2609 (1) @ (AD) 22.000" x (AB) 18.000"
w/ 7503 on Corner B

NEW

MACHINING SERVICES

Part Description:

The anchor fastener clearance notch is used to clear an anchor fastener when a panel will mount inside a T-slot. This notch is used on mesh, plastic panels and aluminum plates up to .250" (6.35mm) thick. See pages 212-216 for information on anchor fasteners. **Additional Information:** When ordering this machining service, specify a vertical or horizontal orientation.

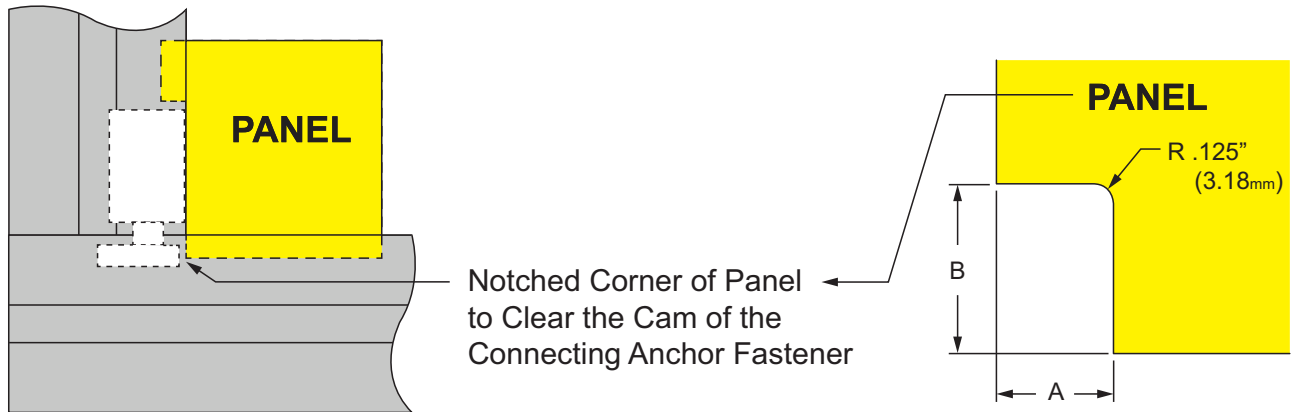

Notched Corner of Panel to Clear the Cam of the Connecting Anchor Fastener

Panel & Wire Part No.	Aluminum Part No.	Series	Service Type	A	B	Cut Tolerance
7311	7215	10	Corner Notch	.375"	1.063"	+/- .060"
7312	7216	15		.500"	1.750"	
20-7311	20-7215	20		8.00mm	24.00mm	+/- 1.52mm
25-7311	25-7215	25		9.50mm	27.00mm	
30-7312	30-7216	30		11.00mm	34.00mm	
40-7312	40-7216	40		12.70mm	44.50mm	

Ordering Example:

2609 (1) @ (AD) 18.000" x (AB) 21.000"
w/ 7312 Vertical on Corner B

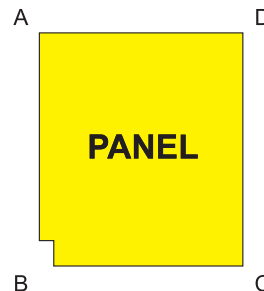

Central Connector Clearance Notch

Part Description:

The central connector clearance notch is used to clear a central connector when a panel will mount inside a T-slot. This notch is used on mesh, plastic panels and aluminum up to .250" (6.35mm) thick. See page 223 for information on central connectors. **Additional Information:** When ordering this machining service, specify a vertical or horizontal orientation.

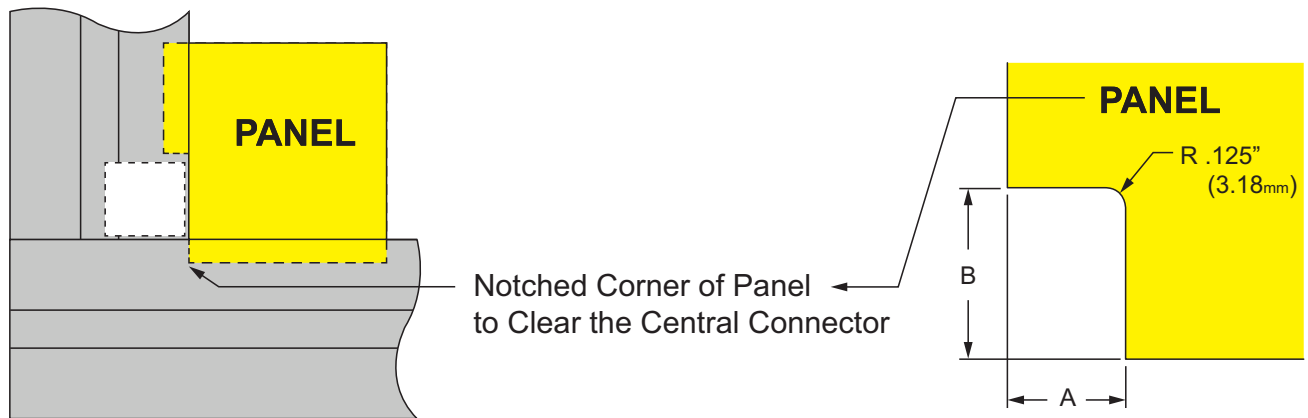

Panel & Wire Part No.	Aluminum Part No.	Series	Service Type	A	B	Cut Tolerance
7320	7204	15	Corner Notch	.500"	2.000"	+/- .060"
40-7320	40-7204	40		12.70mm	50.80mm	+/- 1.52mm
45-7320	45-7204	45		14.00mm	46.00mm	

Ordering Example:

2609 (1) @ (AD) 23.000" x (AB) 28.000"
w/7320 Vertical on Corner B

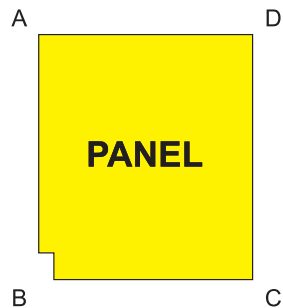

Part Description:

The corner connector clearance notch is used to clear corner connector tabs when a panel will mount inside a T-slot. This notch is used on mesh, plastic panels and aluminum plates up to .250" (6.35mm) thick.

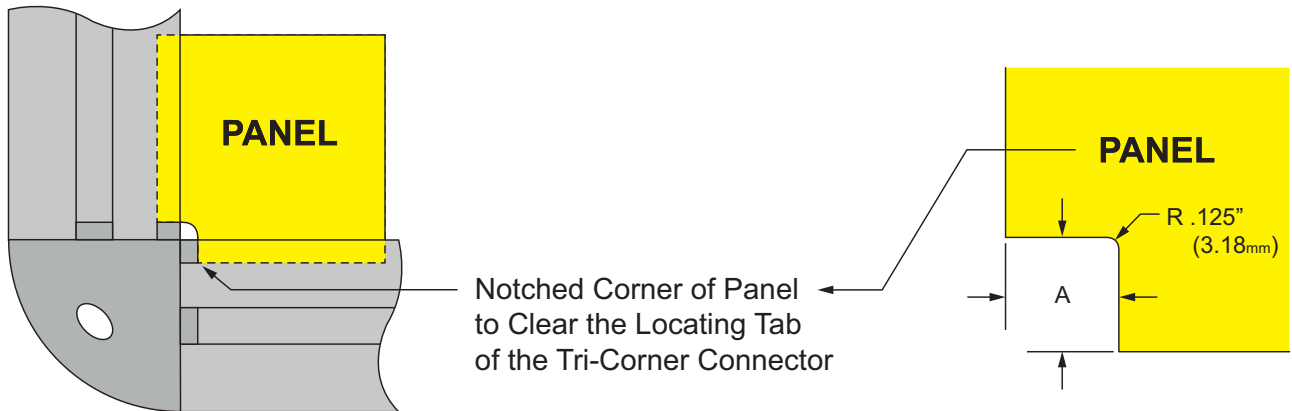

Panel & Wire Part No.	Aluminum Part No.	Series	Service Type	A	Cut Tolerance
7515	7217	10	Corner Notch	.347"	+/- .060"
7516	7218	15		.500"	
25-7515	25-7217	25		8.81mm	+/- 1.52mm
40-7516	40-7218	40		14.75mm	

Ordering Example:

2609 (1) @ (AD) 18.000" x (AB) 18.000"
w/ 7515 on Corner B

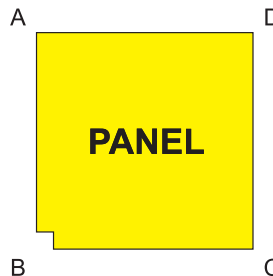

Inside Corner Connector Clearance Notch

Part Description:

The inside corner connector clearance notch is used to clear an inside corner connector when a panel will mount inside a T-slot. This notch is used on mesh, plastic panels and aluminum plates up to .250" (6.35mm) thick. See page 222 for information on inside corner connectors.

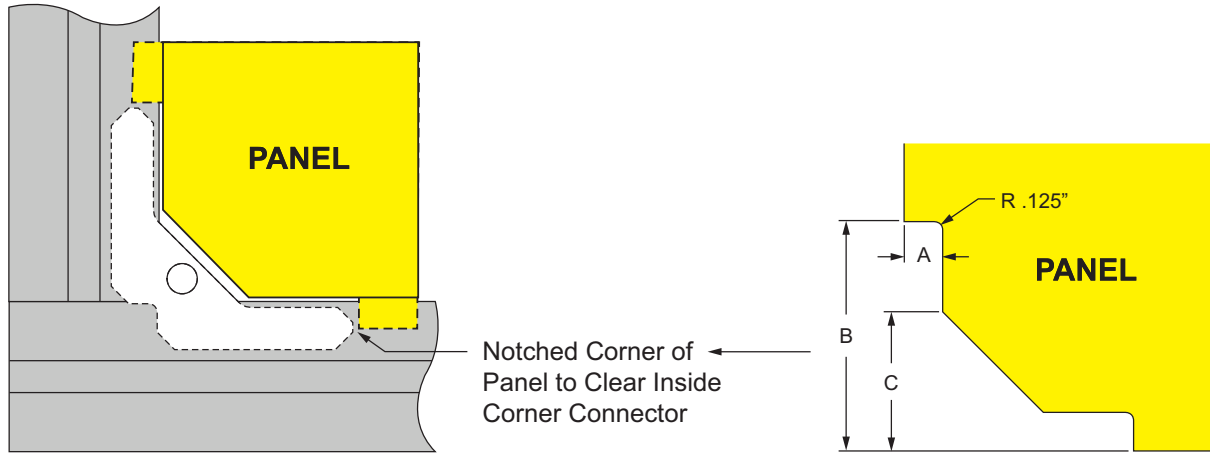

Panel & Wire Part No.	Aluminum Part No.	Series	Service Type	A	B	C	Cut Tolerance
7161	7219	15 40	Corner Notch	.435"	2.500"	1.393"	+/- .060"

Ordering Example:

2609 (1) @ (AD) 22.000" x (AB) 18.000"
w/ 7161 on Corner B

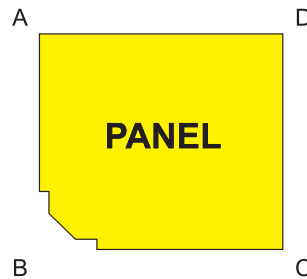

Part Description:

The hidden corner connector clearance notch is used to clear a hidden corner connector when a panel will mount inside a T-slot. See page 220 for information on hidden corner connectors. Two styles are available; one for the inside to inside corner connector and one for the inside to outside corner connector.

Additional Information: When ordering this machining service for inside to outside hidden corner connector, specify a vertical or horizontal orientation.

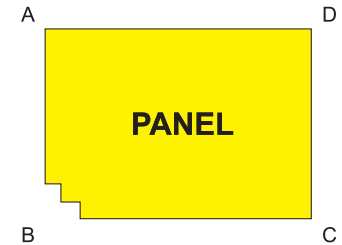
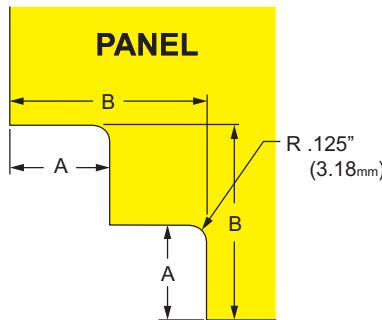
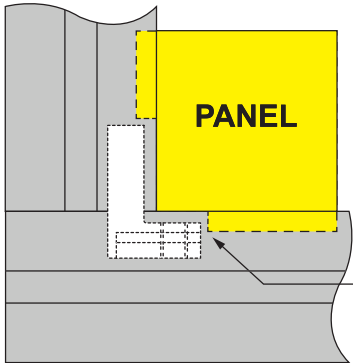

Ordering Example:
2609 (1) @ (AD) 22.000" x (AB) 18.000"
w/ 7522 on Corner B

Inside to Inside: 7522, 30-7522, 40-7522, 45-7522

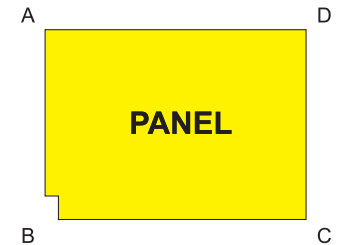
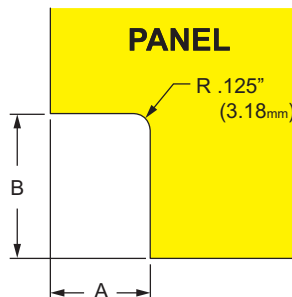
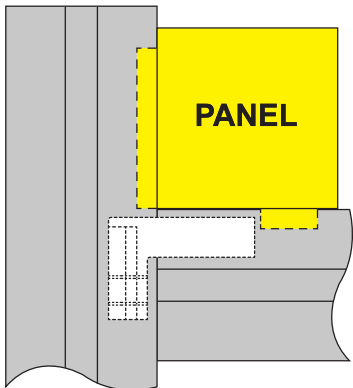

Ordering Example:
2609 (1) @ (AD) 18.000" x (AB) 21.000"
w/ 7523 Vertical on Corner B

Inside to Outside: 7523, 30-7523, 40-7523, 45-7523

Panel & Wire Part No.	Series	Service Type	Connector Part No.	A	B	Cut Tolerance
7522	15	Corner Notch for Inside to Inside Hidden Connector	33450	.405"	1.263"	+/- .060"
7523	15	Corner Notch for Inside to Outside Hidden Connector	33470	.405"	1.263"	
30-7522	30	Corner Notch for Inside to Inside Hidden Connector	33450	8.25mm	30.04mm	+/- 1.52mm
30-7523	30	Corner Notch for Inside to Outside Hidden Connector	33470	8.25mm	30.04mm	
40-7522	40	Corner Notch for Inside to Inside Hidden Connector	33450	11.76mm	33.55mm	
40-7523	40	Corner Notch for Inside to Outside Hidden Connector	33470	11.76mm	33.55mm	
45-7522	45	Corner Notch for Inside to Inside Hidden Connector	33490	12.75mm	41.76mm	
45-7523	45	Corner Notch for Inside to Outside Hidden Connector	33530	12.75mm	41.76mm	

Bolt Connector / Plate Connector Clearance Notch

Part Description:

The bolt connector and plate connector clearance notches are used to clear a bolt connector or plate connector when a panel will mount inside a T-slot. This notch is used on mesh and plastic panels up to 6mm thick. See page 224 for information on bolt connectors and page 225 for plate connectors. **Additional Information:** When ordering this machining service, specify a vertical or horizontal orientation.

Bolt Connector Clearance Notch

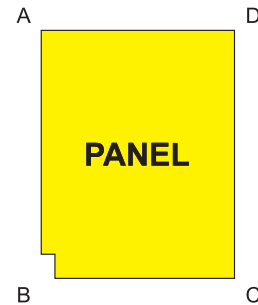
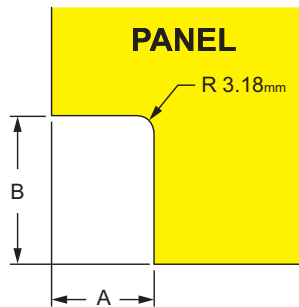
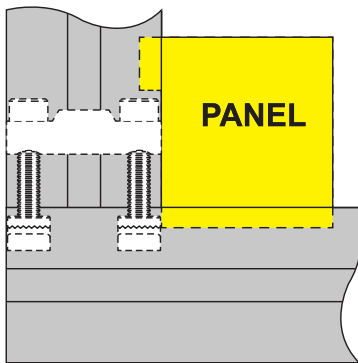

Ordering Example:

65-2609 (1) @ (AD) 580.00mm x (AB) 720.00mm
w/ 30-7314 Vertical on Corner B

Panel & Wire Part No.	Series	Service Type	A	B	Cut Tolerance
30-7314	30	Corner Notch	11.00mm	30.00mm	+/- 1.52mm
45-7317	45		14.00mm	47.00mm	

Plate Connector Clearance Notch

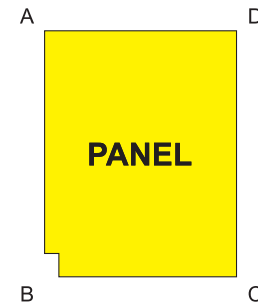
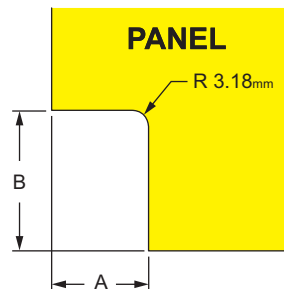
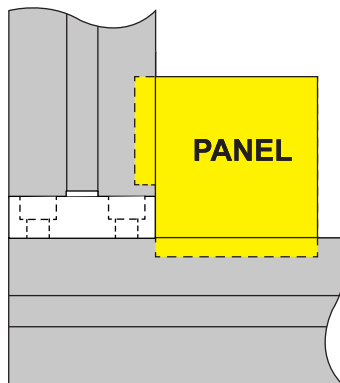

Ordering Example:

65-2609 (1) @ (AD) 580.00mm x (AB) 720.00mm
w/ 45-7323 Horizontal on Corner B

Panel & Wire Part No.	Series	Service Type	A	B	Cut Tolerance
45-7323	45	Corner Notch	14.00mm	27.00mm	+/- 1.52mm



80/20[®] Grabber™ Door Catch / Locking Grabber™ Handle Panel Milling

Part Description:

The Grabber™ door catch and Grabber™ handle milling services are used to add a handle to a plastic panel or aluminum plate. The Grabber™ door catch milling provides clearance for the door catch while the Grabber™ handle milling service machines a hole to enable quick and simple installation of the handle. See page 576 for information on the Grabber™ door catch and page 566 for the locking plastic panel Grabber™ handle.

Grabber™ Door Catch Panel Milling

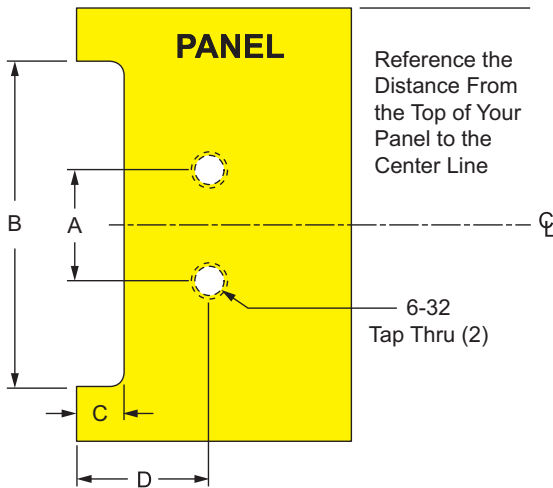

Part No.	Series	A	B	C	D	Cut Tolerance
7313	F	1.600"	4.750"	.313"	1.125"	+/- .020"
65-7313	M	40.60mm	120.70mm	8.00mm	28.60mm	+/- .50mm

Locking Grabber™ Handle Panel Milling

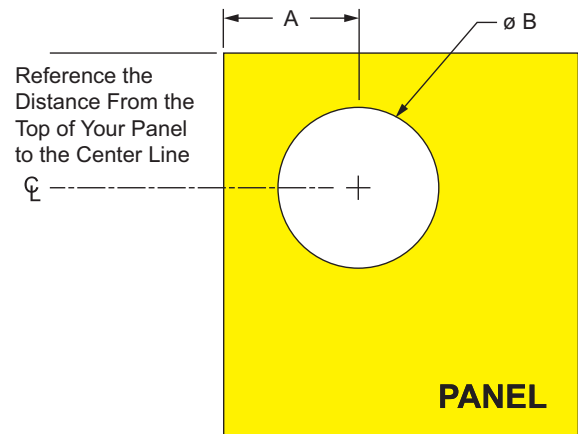

Part No.	Series	A	B	Hole Location Tolerance
7510	F	2.000"	2.000"	+/- .010"
65-7510	M	50.80mm	50.80mm	+/- .25mm

Ordering Example:

2609 (1) @ (AD) 18.000" x (AB) 22.000"
w/ 7313 on Side AB @ 12.000"

(All machining center lines will be called out from point "A" on the panel)

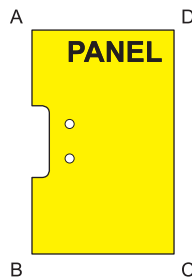

Ordering Example:

2609 (1) @ (AD) 18.000" x (AB) 18.000"
w/ 7510 on Side AB @ 9.000"

(All machining center lines will be called out from point "A" on the panel)

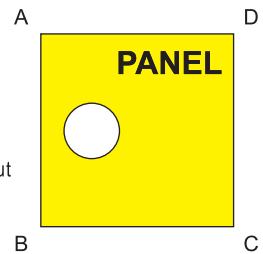

Flush Handle Plastic Panel Milling

Part Description:

The flush handle plastic panel milling service is used with plastic panels to provide a slot which enables quick installation of a flush plastic panel handle. For more information on this handle see page 564.

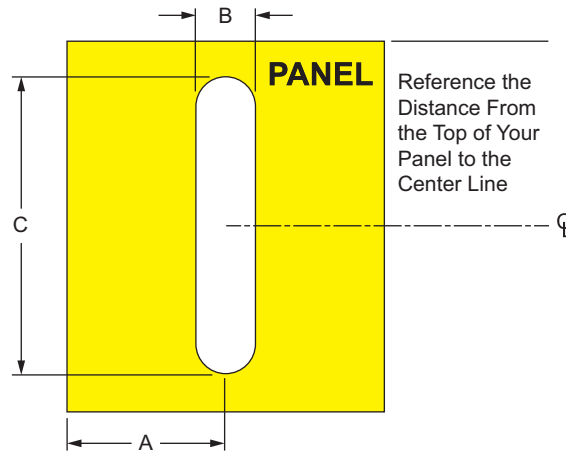

Part No.	Series	Handle Part No.	A	B	C	Hole Location Tolerance
7520	F	2056	2.000"	.625"	3.000"	+/- .010"
7521	F	2058	2.000"	.625"	4.125"	
65-7520	M	65-2056	50.80mm	15.88mm	76.20mm	+/- .25mm
65-7521	M	65-2058	50.80mm	15.88mm	104.78mm	

MACHINING SERVICES

Ordering Example:

2609 (1) @ (AD) 18.000" x (AB) 20.000"
w/ 7520 side AB @ 10.000"

(All machining center lines will be called out from point "A" on the panel)

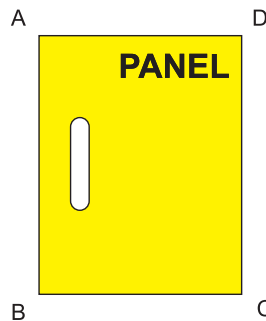

Adjustable Tension and Detent Hinge Plastic Panel Milling

Part Description:

The adjustable tension and detent hinge plastic panel milling is used to create through holes for mounting adjustable tension and detent panel hinges to a plastic panel. For more information on these hinges see pages 541-543, respectively.

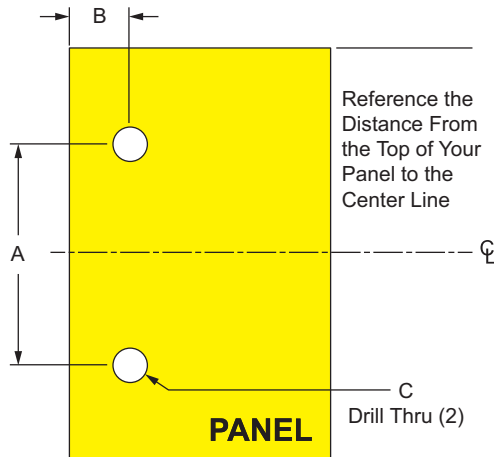

Part No.	Series	Hinge Part No.	Hinge Type	A	B	C	Hole Location Tolerance
7581	10	2081	Adjustable	1.250"	.438"	.201"	+/- .010"
7582	10	2071	Detent	1.250"	.440"	.188"	
7580	15	2080	Adjustable	1.880"	.688"	.375"	
7583	15	2091	Detent	1.340"	.530"	.250"	
25-7581	25	25-2081	Adjustable	31.75mm	11.13mm	5.11mm	+/- .25mm
25-7582	25	25-2071	Detent	31.75mm	11.18mm	4.78mm	
40-7580	40	40-2080	Adjustable	47.75mm	17.48mm	9.53mm	
40-7583	40	40-2091	Detent	34.04mm	13.46mm	6.35mm	

Ordering Example:

2609 (1) @ (AD) 18.000" x (AB) 20.000"
w/ 7581 on Side AB @ 5.000"

(All machining center lines will be called out from point "A" on the panel)

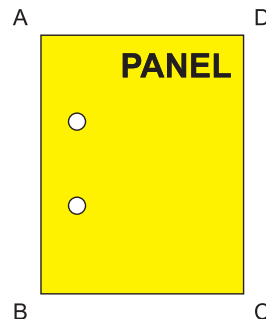

Plastic Door Handle / Steel Door Handle Plastic Panel Milling

Part Description:

The plastic door handle and steel door handle milling services provide through holes for mounting plastic and steel door handles to plastic panels. See page 558 for information on the plastic door handle and page 563 for the steel door handle.

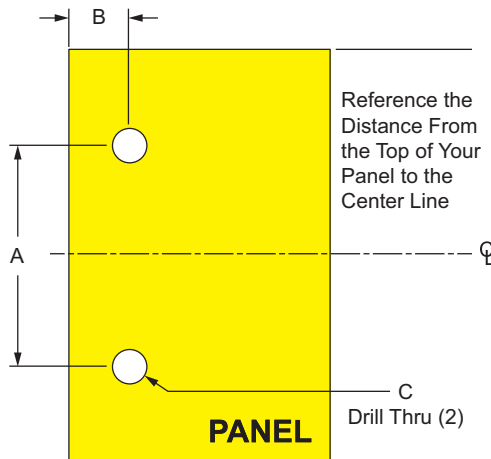

Plastic Door Handle

Part No.	Series	Handle Part No.	A	B	C	Hole Location Tolerance
7586	F	2062 / 2882	3.678"	1.250"	.313"	+/- .010"
7585	F	2061 / 2881	4.600"	1.250"	.375"	
7584	F	2060 / 2880	7.050"	1.250"	.375"	
25-7586	M	25-2062 / 25-2882	93.42mm	31.75mm	9.53mm	+/- .25mm
40-7585	M	40-2061 / 40-2881	116.84mm	31.75mm	9.53mm	
40-7584	M	40-2060 / 40-2880	179.04mm	31.75mm	7.95mm	

Steel Door Handle

Part No.	Series	Handle Part No.	A	B	C	Hole Tolerance
7587	F	2070	3.000"	1.000"	.188"	+/- .010"
65-7587	M	65-2070	76.20mm	25.40mm	4.78mm	+/- .25mm

Ordering Example:

2609 (1) @ (AD) 18.000" x (AB) 20.000"
w/ 7584 on Side AB @ 10.000"

(All machining center lines will be called out from point "A" on the panel)

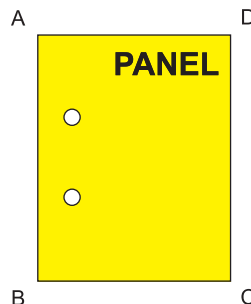

Part Description:

The panel mount block plastic panel milling service is used to provide a through hole for mounting a plastic panel to a panel mount block. For more information on panel mount blocks see pages 471-475.

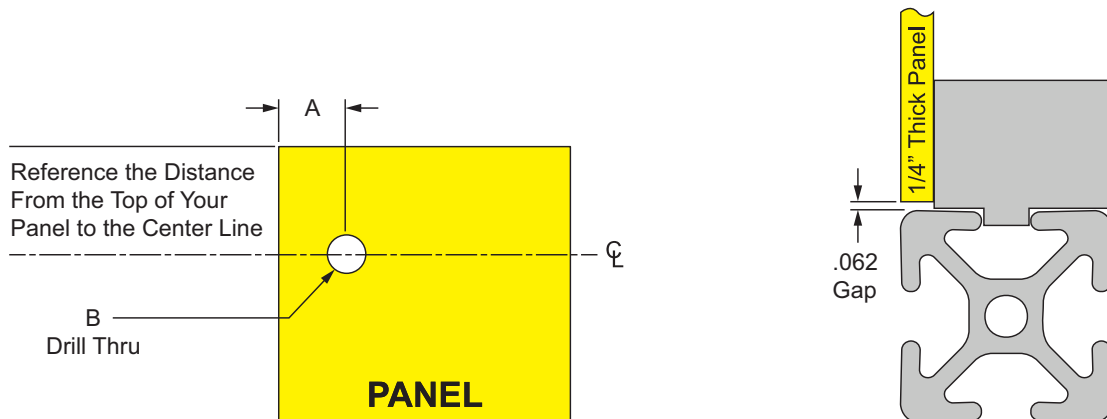

Part No.	Series	A	B	Hole Location Tolerance
7589	10	.313"	.313"	+/- .010"
7588	15	.375"	.375"	
25-7589	25	8.48mm	8.00mm	+/- .25mm
40-7588	40	10.08mm	10.00mm	

Ordering Example:

2609 (1) @ (AD) 18.000" x (AB) 18.000"
w/ 7589 on Side AB @ 9.000"

(All machining center lines will be called out from point "A" on the panel)

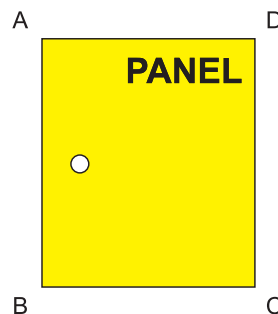

Panel Retainer Milling

Part Description:

The panel retainer milling service provides through holes for mounting a single arm narrow or wide retainer to plastic panels. See pages 482-485 for information on single arm panel retainers.

Single Arm Narrow Panel Retainer

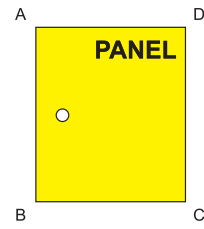
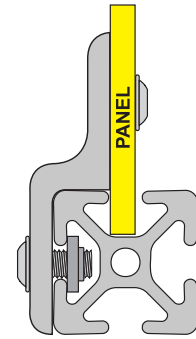
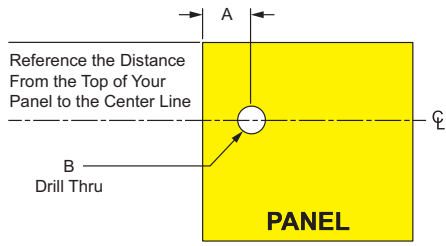

Ordering Example:
 2609 (1) @ (AD) 18.000" x (AB) 18.000"
 w/ 7593 on Side AB @ 4.500"

(All machining center lines will be called out from point "A" on the panel)

Part No.	Series	Retainer Part No.	A	B	Hole Location Tolerance
7593	10	2496 / 2512	.868"	.313"	+/- .010"
7595	15	2434 / 2515	1.290"	.375"	
NEW 20-7593	20	20-2496	16.80mm	6.15mm	+/- .25mm
NEW 25-7593	25	25-2496 / 25-2512	22.50mm	7.92mm	
NEW 30-7595	30	30-2434	24.80mm	9.52mm	
NEW 40-7595	40	40-2434 / 40-2515	35.50mm	9.52mm	
NEW 45-7595	45	45-2434	37.80mm	9.52mm	

Single Arm Wide Panel Retainer

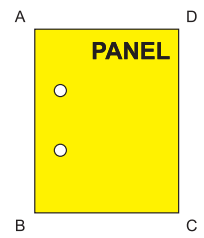
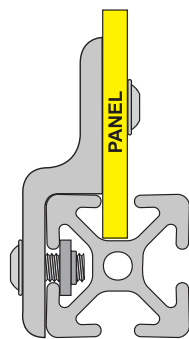
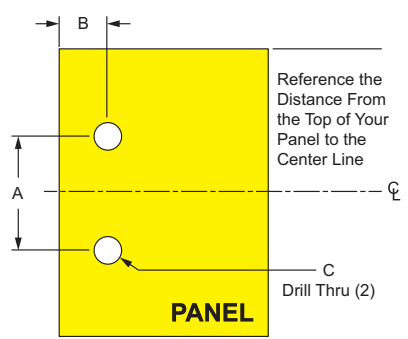

Ordering Example:
 2609 (1) @ (AD) 18.000" x (AB) 20.000"
 w/ 7594 on Side AB @ 8.000"

(All machining center lines will be called out from point "A" on the panel)

Part No.	Series	Retainer Part No.	A	B	C	Hole Location Tolerance
7594	10	2497 / 2513	1.000"	.868"	.313"	+/- .010"
7596	15	2433 / 2516	1.500"	1.290"	.375"	
NEW 20-7594	20	20-2497	20.00mm	16.80mm	6.15mm	+/- .25mm
NEW 25-7594	25	25-2497 / 25-2513	25.40mm	22.50mm	7.92mm	
NEW 30-7596	30	30-2433	30.00mm	24.80mm	9.52mm	
NEW 40-7596	40	40-2433 / 40-2516	38.10mm	35.50mm	9.52mm	
NEW 45-7596	45	45-2433	45.00mm	37.80mm	9.52mm	

MACHINING SERVICES



Part Description:

The plastic panel and aluminum plate cutout machining services provide an opening commonly used for adding a door or access point for a guard or enclosure. **Additional Information:** A drawing is required with this machining service; for project design assistance, contact a Design Technician at www.8020.net.

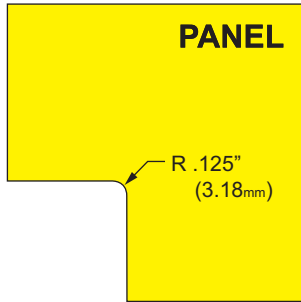

2 Sided Cutout

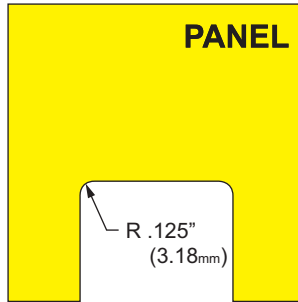

3 Sided Cutout

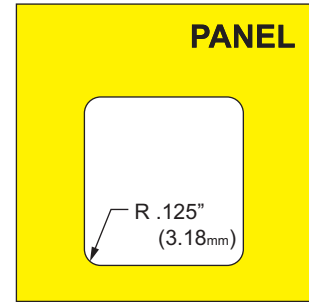

4 Sided Cutout

2 Sided Cutout

Panel Part No.	Aluminum Part No.	Series	Service Type	Cut Tolerance
7162	7171	F	2 Sided Cutout ANY Dimensions > 3.000" Up To .250" Thick	+/- .040"
7182	7190	F	2 Sided Cutout ANY Dimensions > 3.000" Thicker Than .250"	
65-7162	65-7171	M	2 Sided Cutout ANY Dimensions > 80mm Up To 6mm Thick	+/- 1.02mm
65-7182	65-7190	M	2 Sided Cutout ANY Dimensions > 80mm Thicker Than 6mm	

3 Sided Cutout

Panel Part No.	Aluminum Part No.	Series	Service Type	Cut Tolerance
7163	7172	F	3 Sided Cutout ANY Dimensions > 3.000" Up To .250" Thick	+/- .040"
7183	7191	F	3 Sided Cutout ANY Dimensions > 3.000" Thicker Than .250"	
65-7163	65-7172	M	3 Sided Cutout ANY Dimensions > 80mm Up To 6mm Thick	+/- 1.02mm
65-7183	65-7191	M	3 Sided Cutout ANY Dimensions > 80mm Thicker Than 6mm	

4 Sided Cutout

Panel Part No.	Aluminum Part No.	Series	Service Type	Cut Tolerance
7164	7173	F	4 Sided Cutout ANY Dimensions > 3.000" Up To .250" Thick	+/- .040"
7184	7192	F	4 Sided Cutout ANY Dimensions > 3.000" Thicker Than .250"	
65-7164	65-7173	M	4 Sided Cutout ANY Dimensions > 80mm Up To 6mm Thick	+/- 1.02mm
65-7184	65-7192	M	4 Sided Cutout ANY Dimensions > 80mm Thicker Than 6mm	

Top Mount Milling for Plastic Panel or Aluminum Plate

Part Description:

The top mount milling for plastic panels or aluminum plates provides clearance to mount the panel or plate to the face of a profile. This is commonly used for shelves, tabletops, and material handling carts.

Additional Information: The thickness of the panel or plate must be .250" (6mm) or thicker.

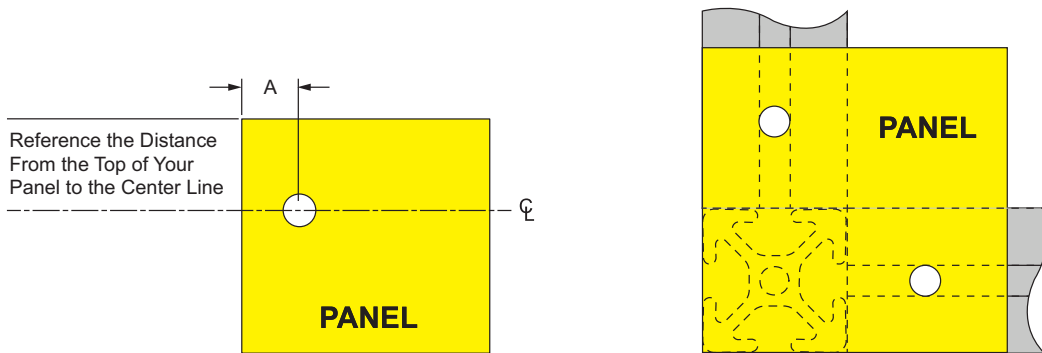

Part No.	Series	Service Type	A	Hole Location Tolerance
7507	10	Drill Thru 0.281" Panel 1/2" from Edge	.500"	+/- .010"
7509	10	Drill Thru & Countersink for 1/4" FHSCS - 1/2" from Edge	.500"	
7508	15	Drill Thru 0.328" Panel 3/4" from Edge	.750"	
7511	15	Drill Thru & Countersink for 5/16" FHSCS - 3/4" from Edge	.750"	
7512	15	Drill Thru & Countersink for 1/4" FHSCS - 3/4" from Edge	.750"	
NEW 20-7507	20	Drill Thru 5.56mm Panel 10.00mm from Edge	10.00mm	+/- .25mm
NEW 20-7509	20	Drill Thru & Countersink for M5 FHSCS - 10.00mm from Edge	10.00mm	
25-7507	25	Drill Thru 7.14mm Panel 12.50mm from Edge	12.50mm	
25-7509	25	Drill Thru & Countersink for M6 FHSCS - 12.50mm from Edge	12.50mm	
NEW 30-7508	30	Drill Thru 8.33mm Panel 15.00mm from Edge	15.00mm	
NEW 30-7511	30	Drill Thru & Countersink for M8 FHSCS - 15.00mm from Edge	15.00mm	
NEW 30-7512	30	Drill Thru & Countersink for M6 FHSCS - 15.00mm from Edge	15.00mm	
40-7508	40	Drill Thru 8.33mm Panel 20.00mm from Edge	20.00mm	
40-7511	40	Drill Thru & Countersink for M8 FHSCS - 20.00mm from Edge	20.00mm	
40-7512	40	Drill Thru & Countersink for M6 FHSCS - 20.00mm from Edge	20.00mm	
NEW 45-7508	45	Drill Thru 8.33mm Panel 22.50mm from Edge	22.50mm	
NEW 45-7511	45	Drill Thru & Countersink for M8 FHSCS - 22.50mm from Edge	22.50mm	
NEW 45-7512	45	Drill Thru & Countersink for M6 FHSCS - 22.50mm from Edge	22.50mm	

Ordering Example:

2609 (1) @ (AD) 18.000" x (AB) 18.000"
w/ 7589 on Side AB @ 9.000"

(All machining center lines will be called out from point "A" on the panel)

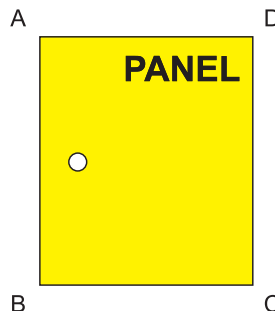



Part Description:

There are several milling services available to assist with custom mesh, plastic panels, and aluminum plate applications. **Additional Information:** A drawing is required with this machining service; for project design assistance contact a Design Technician at www.8020.net.

Circular Cutout Plastic Panel or Aluminum Plate

Panel Part No.	Aluminum Part No.	Series	Service Type	Tolerance
7152	7175	F	Circular Cutout Plastic Panel or Aluminum Plate > 1.000" Not to Exceed 10" Up To .250" Thick	+/- .010"
7186	7194	F	Circular Cutout Plastic Panel or Aluminum Plate > 1.000" Not to Exceed 10" Thicker Than .250"	
65-7152	65-7175	M	Circular Cutout Plastic Panel or Aluminum Plate > 25mm Not to Exceed 250mm Up To 6mm Thick	+/- .25mm
65-7186	65-7194	M	Circular Cutout Plastic Panel or Aluminum Plate > 25mm Not to Exceed 250mm Thicker Than 6mm	

Drill Thru Plastic Panel or Aluminum Plate

Panel Part No.	Aluminum Part No.	Series	Service Type	Tolerance
7159	7180	F	Drill Thru Plastic Panel or Aluminum Plate Up To .250" Thick	+/- .010"
7200	7198	F	Drill Thru Plastic Panel or Aluminum Plate Thicker Than .250"	
65-7159	65-7180	M	Drill Thru Plastic Panel or Aluminum Plate Up To 6mm Thick	+/- .25mm
65-7200	65-7198	M	Drill Thru Plastic Panel or Aluminum Plate Thicker Than 6mm	

Drill Thru and Countersink Plastic Panel or Aluminum Plate

Panel Part No.	Aluminum Part No.	Series	Service Type	Tolerance
7156	7177	F	Drill Thru & Countersink Plastic Panel or Aluminum Plate Up To .250" Thick	+/- .010"
7188	7196	F	Drill Thru & Countersink Plastic Panel or Aluminum Plate Thicker Than .250"	
65-7156	65-7177	M	Drill Thru & Countersink Plastic Panel or Aluminum Plate Up To 6mm Thick	+/- .25mm
65-7188	65-7196	M	Drill Thru & Countersink Plastic Panel or Aluminum Plate Thicker Than 6mm	

Drill Thru and Tap Plastic Panel or Aluminum Plate

Panel Part No.	Aluminum Part No.	Series	Service Type	Tolerance
7158	7178	F	Drill Thru & Tap Plastic Panel or Aluminum Plate Up To .250" Thick	+/- .010"
7189	7197	F	Drill Thru & Tap Plastic Panel or Aluminum Plate Thicker Than .250"	
65-7158	65-7178	M	Drill Thru & Tap Plastic Panel or Aluminum Plate Up To 6mm Thick	+/- .25mm
65-7189	65-7197	M	Drill Thru & Tap Plastic Panel or Aluminum Plate Thicker Than 6mm	

CONTINUE

Miscellaneous Panel Milling Services (Continued)

Miter Cut Plastic Panel or Aluminum Plate

Panel Part No.	Aluminum Part No.	Series	Service Type	Tolerance
7157	7181	F	Miter Cut Plastic Panel or Aluminum Plate Up To .250" Thick	+/- .010"
7201	7199	F	Miter Cut Plastic Panel or Aluminum Plate Thicker Than .250"	
65-7157	65-7181	M	Miter Cut Plastic Panel or Aluminum Plate Up To 6mm Thick	+/- .25mm
65-7201	65-7199	M	Miter Cut Plastic Panel or Aluminum Plate Thicker Than 6mm	

Miscellaneous Plastic Panel or Aluminum Plate

Panel Part No.	Aluminum Part No.	Series	Service Type	Tolerance
7166	7174	F	Miscellaneous Plastic Panel or Aluminum Plate Notch ALL Dimensions ≤ 3.000" Up To .250" Thick	+/- .010"
7185	7193	F	Miscellaneous Plastic Panel or Aluminum Plate Notch ALL Dimensions ≤ 3.000" Thicker Than .250"	
65-7166	65-7174	M	Miscellaneous Plastic Panel or Aluminum Plate Notch ALL Dimensions ≤ 75mm Up To 6mm Thick	+/- .25mm
65-7185	65-7193	M	Miscellaneous Plastic Panel or Aluminum Plate Notch ALL Dimensions ≤ 75mm Thicker Than 6mm	

Mill Finish Sanding Aluminum Plate

Aluminum Part No.	Series	Service Type	Tolerance
7513	F	Mill Finish Sanding Aluminum Plate ALL Dimensions ≤ 48"	—
7514	F	Mill Finish Sanding Aluminum Plate ANY Dimensions > 48"	
65-7513	M	Mill Finish Sanding Aluminum Plate ALL Dimensions ≤ 1220mm	—
65-7514	M	Mill Finish Sanding Aluminum Plate ANY Dimensions > 1220mm	

Pictorial Table Of Contents



Ball End Fold Out Combo Tool



Page 900

Ball Driver & "L" Wrench Set



Page 900

Ball End Power Bits



Page 901

Ball End "L" Hex Wrenches



Page 901

Cheater Pipe



Page 902

Ball End Hex Drivers



Page 902

"T" Ball End Hex Wrench

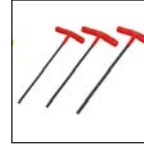

Page 903

Combination Wrenches



Page 903

Six Lobe Tools



Page 904

Ball End Hex Socket



Page 904

Access Hole Drills



Page 905

Access Hole Drill Jigs



Page 905

Anchor Fastener Counterbore Cutters



Page 906

Soft Face Mallet



Page 906

Roll Pin Punch



Page 907

Attitude Lapel Pins



Page 907

Fastener/Hex Tool Size Reference

This chart is a quick reference when looking for the correct size of hex wrench to use with 80/20 fasteners.

Thread Size	Fastener Head			
	SHCS	BHSCS	FBHSCS	FHSCS
8-32	---	3/32"	---	---
10-32	5/32"	1/8"	---	---
1/4-20	3/16"	5/32"	5/32"	5/32"
5/16-18	1/4"	3/16"	3/16"	3/16"
3/8-16	5/16"	---	---	7/32"
M5	4mm	3mm	---	3mm
M6	5mm	4mm	---	4mm
M8	6mm	5mm	---	5mm
M10	8mm	6mm	---	6mm

Ball End Fold Out Combo Tool / Ball Driver and "L" Wrench Set

Ball End Fold Out Combo Tool



65-6086



6087



65-6088



6089

Part No.	Series	Head Type	Included Tool Head Sizes	Weight
6087	F	Ball End	3/16", 7/32", 1/4", 5/16", 3/8"	.637 lb
6089	F	Hex End	5/64", 3/32", 7/64", 1/8", 9/64", 5/32", 3/16", 7/32", 1/4"	.342 lb
65-6086	M	Ball End	5mm, 6mm, 7mm, 8mm, 10mm	.3134 kg
65-6088	M	Hex End	2mm, 2.5mm, 3mm, 4mm, 5mm, 6mm, 8mm	.1705 kg

Ball Driver and "L" Wrench Set



65-6106



6111

Part No.	Series	Included Tool Head Sizes	Weight
6111	F	.050", 1/16", 5/64", 3/32", 7/64", 1/8", 9/64", 5/32", 3/16", 7/32", 1/4", 5/16", 3/8"	.881 lb
65-6106	M	1.5mm, 2mm, 2.5mm, 3mm, 4mm, 5mm, 6mm, 8mm, 10mm	.3660 kg



80/20[®] Inc.

Ball End Power Bits / Ball End "L" Hex Wrenches

Ball End Power Bits



Part No.	Series	Bit Size	Weight
6090	F	3/16"	.043 lb
6095	F	1/4"	.043 lb
65-6091	M	5mm	.0199 kg
65-6092	M	6mm	.0195 kg

Ball End "L" Hex Wrenches



Part No.	Series	Tool Head Size	Weight
6100	F	5/32"	.030 lb
6010	F	3/16"	.046 lb
6040	F	1/4"	.102 lb
65-6096	M	3mm	.0070 kg
65-6097	M	4mm	.0145 kg
65-6098	M	5mm	.0246 kg
65-6099	M	6mm	.0408 kg

Cheater Pipe / Ball End Hex Drivers

80/20[®] Inc.

Cheater Pipe



Part No.	Series	Description	Weight
6005	F M	Fits over "L" hex wrenches up to 1/4" (M6) size	.103 lb

Ball End Hex Drivers



Part No.	Series	Tool Head Size	Weight
6105	F	5/32"	.148 lb
6020	F	3/16"	.161 lb
6050	F	1/4"	.313 lb
65-6102	M	4mm	.0666 kg
65-6103	M	5mm	.0771 kg
65-6104	M	6mm	.1360 kg

80/20® "T" Handle Ball End Hex Wrenches / Combination Wrenches

"T" Handle Ball End Hex Wrenches



Part No.	Series	Tool Head Size	Weight
6110	F	5/32"	.159 lb
6000	F	3/16"	.327 lb
6030	F	1/4"	.409 lb
65-6107	M	4mm	.0730 kg
65-6108	M	5mm	.1510 kg
65-6109	M	6mm	.1737 kg

Combination Wrenches



Part No.	Series	Tool Head Size	Hex Nut Size	Weight
6065	F	7/16"	1/4-20	.158 lb
6080	F RT	1/2"	5/16-18	.189 lb

Six Lobe Tools / Ball End Sockets

Six Lobe Tools



Part No.	Series	Bit Size	Weight
6066	F M	Six Lobe "L" Wrench - 40IP	.088 lb
6067	F M	Six Lobe "L" Wrench - 50IP	.181 lb
6073	F M	Six Lobe Power Bit - 40IP	.041 lb
6069	F M	Six Lobe "T" Handle Wrench - 40IP	.342lb
65-6068	M	Six Lobe Power Bit - 50IP	.0181 kg
65-6071	M	Six Lobe "T" Handle Wrench - 50IP	.2939 kg

Ball End Hex Sockets



Part No.	Series	Socket Size	Weight
6001	F	3/16"	.116 lb
6002	F	1/4"	.149 lb
6003	M	5mm	.0548 kg
6004	M	6mm	.0657 kg

* Use with a 3/8" drive ratcheting or pneumatic socket wrench.

Access Hole Drills



Part No.	Series	Bit Size	Weight
6115	10	.201 x 2.30"	.023 lb
6070	15	.281 x 2.68"	.052 lb
25-6115	25	ø5.1mm	.0104 kg
40-6070	40	ø7.1mm	.0231 kg

Access Hole Drill Jigs



Fractional Part No.	Series	Description	Metric Part No.	Series	Description	Hole Size	Weight
6120	10	Jig for 1010 Profile	25-6120	25	Jig for 25-2525 Profile	.201" (5.1mm)	.142 lb
6131	10	Jig for 1020 Profile	25-6131	25	Jig for 25-2550 Profile	.201" (5.1mm)	.146 lb
6136	10	Jig for 2020 Profile	25-6136	25	Jig for 25-5050 Profile	.201" (5.1mm)	.290 lb
6121	10	Bushing for 10 Series	25-6121	25	Bushing for 25 Series	.201" (5.1mm)	.015 lb
6075	15	Jig for 1515 Profiles	40-6075	40	Jig for 40-4040 Profiles	.281" (7.1mm)	.342 lb
6130	15	Jig for 1530 Profiles	40-6130	40	Jig for 40-4080 Profiles	.281" (7.1mm)	.392 lb
6135	15	Jig for 3030 Profiles	40-6135	40	Jig for 40-8080 Profiles	.281" (7.1mm)	.852 lb
6076	15	Bushing for 15 Series	40-6076	40	Bushing for 40 Series	.281" (7.1mm)	.033 lb

Anchor Fastener Counterbore Cutters / Soft Face Mallet

Anchor Fastener Counterbore Cutters



Part No.	Series	Mill Diameter	Weight
6160	10	9/16"	.180 lb
6060	15	13/16"	.335 lb
25-6160	25	14.3mm	.0816 kg
40-6060	40	20.0mm	.1859 kg

* Two flute center cutting

Soft Face Mallet



Part No.	Series	Weight
6055	F M QF	.753 lb

Roll Pin Punch



Part No.	Series	Weight
6117	RT	.293 lb

Attitude Lapel Pins



8020



8030

Part No.	Description	Weight
8020	Deluxe Attitude Lapel Pin	.004 lb
8030	Economy Attitude Lapel Pin	.005 lb

We'd Like to Hear From You! Share Your Design

As a **"Thank you"** for sharing your 80/20 solutions we are offering you an incentive. For each project submission you will be entered into a drawing to win a coupon for your next online order.



Get ideas and inspiration with our online photo gallery!



Platform with Stairs

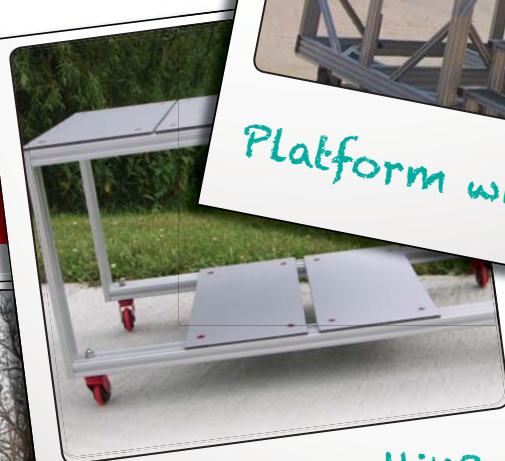

Material Handling Cart



Art Sculpture



Musical Stand

Visit 8020.net for more information or to submit your application



Registered Trademarks Used Throughout The 80/20® Catalog

3D ContentCentral®..... is a registered trademark of Dassault Systèmes
 Alucobest™..... is a registered trademark of Shanghai Huayuan New Composite Materials Co., LTD
 Alumalite™..... is a registered trademark of Laminators, Inc.
 AutoCAD®..... is a registered trademark of Autodesk Inc.
 Grabber™..... is a registered trademark of Southco, Inc.
 Inventor®..... is a registered trademark of Autodesk Inc.
 Kydex®..... is a registered trademark of Kleerdex Company
 LNP™ Stat-Kon™..... is a registered trademark of SABIC
 Loctite®..... is a registered trademark of Henkel AG & Company
 Mighty Mount®..... is a registered trademark of WilliMount Corporation
 PARTsolutions®..... is a registered trademark of PARTsolutions, LLC
 Solidworks®..... is a registered trademark of SolidWorks Corporation
 Velcro®..... is a registered trademark of Velcro Industries B.V.
 Wilsonart®..... is a registered trademark of Premark RWP Holdings, Inc.
 Wiremold®..... is a registered trademark of The Wiremold Company

Metric / U.S. Customary Unit Equivalents

Linear				
inches	x 25.40	= millimeter (mm)	x 0.03937	= inches
feet	x 0.3048	= meters (m)	x 3.281	= feet
yards	x 0.9144	= meters (m)	x 1.0936	= yards
miles	x 1.6093	= kilometers (km)	x 0.6214	= miles
inches	x 2.540	= centimeters (cm)	x 0.3937	= inches
microinches	x 0.0254	= micrometers (um)	x 39.37	= microinches
Area				
inches ²	x 645.16	= millimeters ² (mm ²)	x 0.00155	= inches ²
inches ²	x 6.452	= centimeters ² (cm ²)	x 0.155	= inches ²
feet ²	x 0.0929	= meters ² (m ²)	x 10.764	= feet ²
yards ²	x 0.8361	= meters ² (m ²)	x 1.196	= yards ²
acres	x 0.4047	= hectares (10 ⁴ m ²) or (ha)	x 2.471	= acres
miles ²	x 2.590	= kilometers ² (km ²)	x 0.3861	= miles ²
Mass				
ounces (av)	x 28.35	= grams (g)	x 0.03527	= ounces (av)
pounds (av)	x 0.4536	= kilograms (kg)	x 2.2046	= pounds (av)
tons (2000 lb)	x 907.18	= kilograms (kg)	x 0.001102	= tons (2000 lb)
tons (2000 lb)	x 0.90718	= metric tons (t)	x 1.1023	= tons (2000 lb)
pounds/foot	x .671969	= kilograms/meter	x 1.4888	= pounds/foot
Force				
ounces - f	x 0.278	= newtons (N)	x 3.597	= ounces - f
pounds - f	x 4.448	= newtons (N)	x 0.2248	= pounds - f
kilograms - f	x 9.807	= newtons (N)	x 0.10197	= kilograms - f

Part Number Index

1001.....	66, 77	2028.....	785	2095.....	520	2147.....	631
1001-S.....	66, 76	2030.....	785	2096.....	522	2148.....	634
1002.....	66, 79	2035.....	786	2097.....	523	2150.....	750
1002-S.....	66, 78	2036.....	787	2098.....	524	2151.....	750
1003.....	66, 81	2037.....	787	2099.....	812	2152.....	750
1003-S.....	66, 80	2040.....	67, 95	2100.....	812	2153.....	750
1004.....	66, 83	2040-S.....	67, 94	2101.....	525	2154.....	752
1004-S.....	66, 82	2045.....	785	2102.....	526	2155.....	752
1010.....	66, 75	2046.....	785	2103.....	527	2156.....	758
1010-S.....	66, 74	2050.....	785	2104.....	525	2157.....	758
1012.....	66, 85	2051.....	510	2105.....	526	2159.....	752
1012-S.....	66, 84	2052.....	568	2106.....	527	2160.....	752
1020.....	66, 89	2053.....	574	2107.....	575	2161.....	755
1020-S.....	66, 88	2054.....	470	2108.....	813	2162.....	754
1030.....	66, 91	2055.....	567	2109.....	792	2163.....	757
1030-S.....	66, 90	2056.....	564	2110.....	792	2164.....	756
1050.....	66, 86	2057.....	585	2111.....	792	2165.....	642
1501.....	67, 103	2058.....	564	2112.....	792	2166.....	642
1501-LS.....	67, 102	2059.....	510	2113.....	792	2167.....	643
1502.....	67, 105	2060.....	558	2114.....	792	2168.....	643
1502-LS.....	67, 104	2061.....	558	2115.....	588	2169.....	645
1503.....	67, 107	2062.....	558	2116.....	588	2170.....	643
1503-LS.....	67, 106	2063.....	567	2117.....	588	2171.....	645
1504.....	68, 109	2064.....	525	2118.....	588	2172.....	754
1504-LS.....	68, 108	2065.....	526	2119.....	791	2173.....	756
1515.....	67, 101	2066.....	527	2120.....	587	2175.....	643
1515-Lite.....	67, 99	2067.....	509	2121.....	577	2177.....	588
1515-LS.....	67, 98	2068.....	509	2122.....	577	2178.....	588
1515-S.....	67, 100	2069.....	576	2123.....	578	2180.....	645
1515-UL.....	67, 97	2070.....	563	2124.....	636	2181.....	611
1515-ULS.....	67, 96	2071.....	542	2125.....	576	2182.....	611
1517.....	68, 113	2073.....	519	2126.....	573	2183.....	611
1517-LS.....	68, 112	2074.....	521	2127.....	638	2184.....	611
1530.....	68, 123	2075.....	520	2128.....	636	2186.....	610
1530-Lite.....	68, 121	2076.....	522	2129.....	636	2187.....	610
1530-LS.....	68, 120	2077.....	523	2130.....	636	2188.....	610
1530-S.....	68, 122	2078.....	524	2131.....	638	2189.....	610
1530-UL.....	68, 119	2079.....	559	2132.....	638	2190.....	614
1530-ULS.....	68, 118	2080.....	541	2133.....	754	2191.....	615
1534-Lite.....	68, 115	2081.....	541	2134.....	584	2192.....	614
1545.....	68, 125	2082.....	569	2135.....	636	2193.....	615
1545-S.....	68, 124	2083.....	569	2136.....	640	2194.....	614
1547.....	68, 110	2084.....	545	2137.....	636	2195.....	615
1575.....	68, 114	2085.....	545	2138.....	636	2200.....	614
2012.....	66, 87	2086.....	545	2139.....	638	2201.....	615
2015.....	785	2087.....	570	2140.....	638	2202.....	614
2020.....	67, 93	2088.....	576	2141.....	640	2203.....	609
2020-S.....	67, 92	2089.....	570	2142.....	640	2204.....	609
2021.....	591	2090.....	579	2143.....	640	2205.....	612
2022.....	786	2091.....	542	2144.....	756	2207.....	613
2025.....	785	2093.....	519	2145.....	638	2208.....	613
2026.....	785	2094.....	521	2146.....	640	2209.....	613

Visit product pages for additional size, anodize and color options.

Part Number Index

2210.....	512	2321.....	600	2428.....	479	2489.....	480
2211.....	512	2323.....	600	2429.....	586	2490.....	490
2215.....	612	2324.....	534	2430.....	479	2491.....	500
2216.....	612	2325.....	534	2431.....	492	2492.....	498
2217.....	612	2326.....	534	2432.....	490	2493.....	492
2220.....	513	2327.....	534	2433.....	484	2494.....	501
2221.....	513	2328.....	534	2434.....	482	2495.....	499
2230-BLU.....	809	2333.....	603	2435.....	501	2496.....	482
2230-RED.....	809	2334.....	603	2436.....	500	2497.....	484
2230-YEL.....	809	2335.....	604	2437.....	499	2500.....	804
2240-BLU.....	809	2336.....	604	2438.....	498	2501.....	804
2240-RED.....	809	2337.....	602	2439.....	758	2502.....	804
2240-YEL.....	809	2338.....	602	2440.....	758	2503.....	804
2250-BLU.....	809	2339.....	811	2441.....	758	2504.....	804
2250-RED.....	809	2340.....	751	2442.....	506	2505.....	804
2250-YEL.....	809	2341.....	751	2446.....	755	2506.....	805
2264.....	810	2349.....	753	2447.....	754	2507.....	805
2265.....	810	2350.....	753	2448.....	757	2508.....	805
2270-BLU.....	809	2361.....	636	2449.....	756	2509.....	805
2270-RED.....	809	2362.....	638	2450.....	759	2510.....	805
2270-YEL.....	809	2363.....	640	2451.....	759	2511.....	805
2271-BLU.....	809	2364.....	640	2452.....	464	2512.....	486
2271-RED.....	809	2365.....	636	2453.....	464	2513.....	488
2271-YEL.....	809	2366.....	638	2454.....	464	2515.....	486
2272-BLU.....	809	2367.....	640	2455.....	464	2516.....	488
2272-RED.....	809	2380.....	646	2456.....	464	2517.....	494
2272-YEL.....	809	2385.....	646	2457.....	464	2518.....	502
2280.....	516	2387.....	646	2460.....	468	2519.....	496
2281.....	515	2390.....	646	2461.....	468	2520.....	503
2282.....	515	2400.....	646	2462.....	468	2521.....	494
2286.....	814	2404.....	648	2463.....	468	2522.....	502
2287.....	815	2405.....	648	2464.....	468	2523.....	496
2290.....	515	2406.....	632	2465.....	592	2524.....	503
2291.....	598	2407.....	632	2467.....	468	2525.....	229
2292.....	598	2408.....	632	2468.....	468	2526.....	229
2293.....	598	2409.....	632	2470.....	468	2527.....	228
2294.....	598	2410.....	646	2471.....	468	2528.....	228
2295.....	598	2413.....	650	2472.....	469	2529.....	228
2296.....	598	2414.....	648	2473.....	469	2530.....	229
2298.....	597	2415.....	648	2474.....	469	2531.....	229
2299.....	597	2416.....	648	2475.....	469	2532.....	228
2300.....	597	2417.....	648	2476.....	469	2533.....	228
2305.....	597	2418.....	629	2477.....	469	2534.....	228
2306.....	597	2419.....	629	2478.....	469	2535.....	229
2307.....	597	2420.....	629	2479.....	468	2536.....	229
2310.....	597	2421.....	478	2480.....	467	2537.....	228
2311.....	601	2422.....	478	2481.....	467	2538.....	228
2312.....	601	2423.....	478	2482.....	467	2539.....	228
2314.....	601	2424.....	586	2483.....	465	2540.....	229
2316.....	601	2425.....	472	2484.....	465	2541.....	229
2317.....	599	2426.....	629	2485.....	465	2542.....	228
2318.....	599	2427.....	472	2488.....	480	2543.....	228

Visit product pages for additional size, anodize and color options.

Part Number Index

2544.....	228	2612.....	453	2664.....	462	2811.....	481
2545.....	229	2613-S.....	455	2666.....	461	2812.....	461
2546.....	228	2613-T.....	455	2667.....	461	2813.....	461
2547.....	228	2614-S.....	455	2668.....	461	2814.....	463
2548.....	228	2614-T.....	455	2669.....	461	2815.....	463
2549.....	228	2615.....	457	2670.....	806	2816.....	793
2550.....	229	2616.....	457	2673.....	806	2817.....	793
2551.....	229	2617.....	457	2674.....	806	2818.....	793
2552.....	229	2618.....	457	2675.....	806	2819.....	793
2553.....	229	2619.....	457	2676.....	806	2820.....	793
2554.....	229	2620.....	457	2700.....	605	2821.....	793
2555.....	229	2621.....	457	2701.....	606	2822.....	793
2556.....	228	2622.....	457	2704.....	605	2823.....	793
2557.....	228	2623.....	457	2705.....	606	2824.....	793
2558.....	228	2624.....	457	2708.....	605	2825.....	793
2559.....	228	2629.....	453	2709.....	606	2826.....	793
2560.....	229	2630.....	453	2712.....	605	2827.....	793
2561.....	228	2631.....	457	2713.....	606	2828.....	796
2562.....	228	2632.....	457	2714.....	607	2829.....	589
2563.....	228	2633.....	459	2715.....	607	2830.....	532
2564.....	228	2634.....	459	2716.....	607	2831.....	531
2565.....	227	2635.....	459	2717.....	607	2832.....	532
2566.....	227	2636.....	459	2730.....	566	2833.....	531
2567.....	227	2637.....	459	2731.....	608	2834.....	589
2568.....	227	2640.....	460	2745.....	580	2835.....	533
2569.....	229	2641.....	451	2750.....	517	2836.....	533
2570.....	227	2642.....	451	2751.....	518	2837.....	530
2571.....	227	2643.....	453	2752.....	517	2838.....	529
2572.....	227	2644.....	453	2753.....	518	2839.....	530
2573.....	227	2645.....	453	2754.....	517	2840.....	529
2574.....	227	2646.....	454	2755.....	518	2841.....	533
2575.....	227	2647.....	454	2756.....	518	2842.....	533
2576.....	229	2648.....	452	2757.....	517	2843.....	817
2577.....	229	2649.....	452	2758.....	518	2844.....	817
2578.....	229	2650.....	458	2759.....	518	2845.....	817
2579.....	229	2651.....	461	2760.....	571	2846.....	817
2580.....	229	2652.....	461	2761.....	571	2849.....	818
2581.....	229	2653.....	461	2763.....	571	2850.....	818
2582.....	229	2654.....	461	2765.....	571	2851.....	816
2583.....	227	2655.....	461	2780.....	565	2852.....	816
2584.....	227	2656.....	461	2781.....	565	2876.....	795
2601.....	450	2657.....	461	2782.....	565	2877.....	795
2602.....	450	2658.....	461	2796.....	747	2880.....	558
2603.....	450	2659.....	462	2797.....	747	2881.....	558
2604.....	450	2660-S.....	456	2798.....	748	2882.....	558
2605.....	450	2660-T.....	456	2799.....	748	2884.....	561
2606.....	450	2661-S.....	456	2800.....	466	2885.....	561
2607.....	450	2661-T.....	456	2802.....	466	2886.....	561
2608.....	450	2662-S.....	456	2804.....	466	2887.....	561
2609.....	453	2662-T.....	456	2806.....	466	2888.....	562
2610.....	453	2663-S.....	456	2808.....	463	2889.....	562
2611.....	453	2663-T.....	456	2810.....	481	2890.....	798

Visit product pages for additional size, anodize and color options.

Part Number Index

2891.....	798	3051.....	385	3122.....	390	3289.....	410
2892.....	798	3052.....	389	3123.....	390	3290.....	400
2893.....	799	3053.....	398	3124.....	390	3293.....	402
2894.....	799	3054.....	385	3125.....	390	3295.....	402
2895.....	800	3055.....	397	3126.....	400	3297.....	402
2899.....	797	3056.....	389	3127.....	390	3299.....	402
2900.....	471	3057.....	389	3128.....	390	3300.....	408
2901.....	623	3058.....	389	3129.....	390	3301.....	408
2902.....	623	3059.....	385	3130.....	390	3302.....	408
2903.....	623	3060.....	69, 130	3131.....	390	3303.....	408
2904.....	623	3061.....	385	3132.....	390	3304.....	407
2905.....	623	3062.....	389	3133.....	390	3305.....	407
2906.....	623	3063.....	385	3134.....	400	3306.....	407
2907.....	623	3064.....	390	3140.....	390	3307.....	407
2908.....	623	3065.....	385	3150.....	409	3308.....	407
2910.....	471	3066.....	387	3151.....	409	3309.....	373
2922.....	569	3067.....	389	3152.....	409	3310.....	373
2923.....	569	3068.....	390	3153.....	409	3311.....	373
2927.....	570	3071.....	390	3154.....	409	3312.....	373
2929.....	570	3072.....	390	3183.....	218	3313.....	373
2932.....	569	3075.....	68, 116	3189.....	218	3315.....	407
2933.....	569	3080.....	390	3201.....	366	3318.....	408
2937.....	570	3081.....	390	3202.....	366	3319.....	408
2939.....	570	3082.....	390	3203.....	366	3320.....	408
2952.....	569	3085.....	383	3204.....	366	3321.....	406
2953.....	569	3086.....	383	3205.....	366	3322.....	406
2957.....	570	3087.....	383	3206.....	366	3323.....	408
2959.....	570	3088.....	383	3208.....	398	3325.....	409
3000.....	408	3090.....	214	3214.....	398	3330.....	388
3002.....	406	3091.....	214	3215.....	398	3340.....	387
3004.....	406	3092.....	215	3258.....	397	3342.....	387
3005.....	385	3093.....	215	3260.....	397	3343.....	219
3006.....	397	3094.....	214	3261.....	397	3344.....	219
3007.....	398	3095.....	214	3262.....	397	3346.....	384
3010.....	365	3096.....	215	3266.....	786	3348.....	384
3011.....	388	3097.....	215	3267.....	786	3351.....	219
3012.....	388	3098.....	214	3272.....	785	3352.....	219
3017.....	393	3099.....	215	3273.....	573	3354.....	213
3018.....	393	3100.....	214	3274.....	785	3355.....	408
3022.....	388	3102.....	215	3275.....	362	3356.....	406
3024.....	385	3104.....	385	3276.....	362	3357.....	408
3030.....	69, 129	3106.....	390	3278.....	363	3358.....	406
3030-Lite.....	69, 127	3110.....	390	3279.....	364	3359.....	212
3030-LS.....	68, 126	3111.....	385	3280.....	364	3360.....	212
3030-S.....	69, 128	3112.....	390	3281.....	364	3361.....	213
3032.....	385	3114.....	385	3282.....	372	3362.....	212
3034-Lite.....	68, 117	3115.....	400	3283.....	372	3363.....	212
3035.....	413	3116.....	400	3284.....	372	3364.....	222
3042.....	385	3117.....	385	3285.....	365	3365.....	407
3044.....	389	3118.....	385	3286.....	362	3366.....	408
3048.....	389	3119.....	390	3287.....	365	3367.....	405
3050.....	385	3120.....	400	3288.....	400	3368.....	222

Visit product pages for additional size, anodize and color options.

Part Number Index

3369.....	216	3429.....	410	3492.....	406	3630.....	408
3370.....	216	3430.....	410	3493.....	407	3632.....	408
3371.....	405	3431.....	410	3494.....	406	3634.....	409
3372.....	405	3432.....	407	3495.....	406	3636.....	409
3373.....	212	3433.....	407	3496.....	406	3638.....	410
3375.....	372	3434.....	407	3497.....	407	3639.....	406
3376.....	372	3435.....	407	3498.....	406	3640.....	409
3378.....	217	3437.....	407	3499.....	408	3642.....	410
3379.....	217	3439.....	408	3500.....	396	3645.....	388
3380.....	217	3441.....	407	3501.....	396	3647.....	405
3381.....	217	3442.....	407	3520.....	405	3649.....	388
3382.....	362	3443.....	408	3521.....	405	3650.....	388
3383.....	218	3445.....	408	3522.....	405	3656.....	398
3384.....	406	3446.....	409	3523.....	405	3657.....	398
3385.....	406	3450.....	409	3524.....	406	3658.....	397
3386.....	406	3452.....	409	3525.....	406	3659.....	397
3387.....	406	3454.....	409	3526.....	407	3660.....	212
3388.....	405	3455.....	409	3527.....	407	3661.....	212
3389.....	218	3456.....	409	3528.....	407	3663.....	385
3390.....	387	3457.....	410	3529.....	408	3665.....	212
3391.....	213	3458.....	410	3530.....	408	3666.....	374
3392.....	212	3459.....	410	3531.....	408	3667.....	374
3393.....	405	3460.....	409	3532.....	406	3668.....	374
3394.....	405	3461.....	407	3533.....	406	3669.....	374
3395.....	212	3462.....	409	3534.....	406	3670.....	374
3396.....	213	3463.....	408	3600.....	372	3671.....	390
3397.....	407	3464.....	409	3601.....	387	3675.....	362
3398.....	405	3465.....	406	3602.....	372	3676.....	363
3399.....	405	3466.....	409	3603.....	387	3677.....	388
3400.....	388	3467.....	407	3604.....	387	3678.....	363
3405.....	388	3468.....	409	3605.....	373	3679.....	217
3406.....	388	3469.....	405	3606.....	388	3680.....	217
3407.....	406	3470.....	410	3607.....	388	3681.....	217
3408.....	405	3471.....	407	3608.....	373	3682.....	217
3409.....	406	3472.....	410	3609.....	385	3685.....	389
3410.....	388	3473.....	410	3610.....	390	3686.....	362
3411.....	388	3474.....	409	3611.....	385	3687.....	389
3412.....	408	3476.....	408	3612.....	390	3688.....	385
3414.....	406	3478.....	408	3613.....	410	3689.....	389
3415.....	406	3479.....	405	3614.....	385	3690.....	385
3416.....	405	3480.....	406	3615.....	390	3691.....	390
3417.....	406	3481.....	406	3617.....	385	3692.....	385
3418.....	405	3482.....	405	3618.....	407	3693.....	389
3419.....	406	3483.....	410	3619.....	390	3694.....	385
3420.....	388	3484.....	405	3620.....	407	3695.....	389
3421.....	410	3485.....	406	3621.....	385	3696.....	385
3422.....	410	3486.....	406	3622.....	390	3697.....	389
3423.....	410	3487.....	410	3624.....	372	3698.....	385
3424.....	410	3488.....	410	3625.....	395	3699.....	409
3426.....	410	3489.....	410	3626.....	395	3703.....	366
3427.....	410	3490.....	406	3627.....	390	3705.....	366
3428.....	410	3491.....	406	3628.....	395	3707.....	398

Visit product pages for additional size, anodize and color options.

Part Number Index

3709.....	398	3814.....	392	3872.....	413	3945.....	386
3714.....	398	3815.....	387	3873.....	366	3946.....	386
3716.....	404	3816.....	415	3874.....	415	3947.....	386
3720.....	404	3817.....	415	3875.....	372	3948.....	386
3737.....	409	3818.....	392	3876.....	372	3950.....	390
3745.....	409	3819.....	387	3877.....	414	3951.....	390
3747.....	393	3820.....	398	3878.....	415	3952.....	390
3748.....	393	3821.....	398	3879.....	364	3953.....	390
3749.....	393	3822.....	392	3880.....	414	3954.....	390
3750.....	393	3824.....	411	3881.....	414	3955.....	390
3751.....	393	3825.....	414	3882.....	414	3956.....	390
3752.....	393	3826.....	411	3883.....	414	3957.....	390
3753.....	393	3827.....	411	3884.....	414	3958.....	390
3754.....	393	3829.....	411	3886.....	414	3960.....	409
3755.....	393	3830.....	413	3887.....	415	3961.....	408
3758.....	399	3831.....	412	3888.....	415	3962.....	410
3759.....	399	3832.....	413	3889.....	414	3963.....	414
3760.....	397	3833.....	412	3890.....	414	3964.....	414
3762.....	397	3834.....	415	3891.....	217	3965.....	415
3764.....	397	3835.....	412	3892.....	373	3970.....	409
3766.....	786	3836.....	362	3894.....	373	3971.....	408
3767.....	786	3838.....	363	3895.....	217	3972.....	410
3778.....	363	3839.....	392	3896.....	212	3974.....	414
3781.....	373	3840.....	415	3897.....	212	3975.....	415
3782.....	372	3841.....	413	3898.....	373	4001.....	346
3783.....	372	3842.....	372	3899.....	415	4002.....	347
3784.....	372	3843.....	372	3900.....	365	4003.....	348
3785.....	362	3844.....	372	3901.....	219	4004.....	358
3786.....	362	3845.....	413	3902.....	219	4005.....	358
3787.....	373	3847.....	413	3903.....	383	4006.....	359
3788.....	373	3849.....	412	3906.....	383	4007.....	360
3789.....	362	3850.....	411	3908.....	383	4008.....	360
3790.....	372	3851.....	400	3910.....	383	4009.....	361
3791.....	372	3852.....	400	3913.....	374	4013.....	300
3792.....	219	3853.....	400	3914.....	374	4014.....	314
3793.....	219	3854.....	400	3915.....	374	4015.....	303
3794.....	219	3855.....	413	3916.....	374	4016.....	315
3795.....	219	3856.....	412	3917.....	374	4017.....	316
3800.....	364	3857.....	400	3919.....	374	4020.....	313
3801.....	391	3859.....	362	3920.....	374	4021.....	273
3802.....	386	3860.....	397	3921.....	374	4022.....	275
3803.....	391	3861.....	397	3922.....	374	4023.....	279
3804.....	386	3862.....	413	3923.....	374	4024.....	743
3805.....	365	3863.....	413	3930.....	380	4025.....	713
3806.....	391	3864.....	415	3931.....	380	4026.....	714
3807.....	391	3865.....	415	3932.....	380	4027.....	715
3808.....	386	3866.....	366	3933.....	380	4028.....	727
3809.....	386	3867.....	411	3940.....	385	4029.....	728
3810.....	392	3868.....	366	3941.....	385	4030.....	729
3811.....	386	3869.....	415	3942.....	385	4031.....	730
3812.....	392	3870.....	414	3943.....	386	4032.....	731
3813.....	387	3871.....	366	3944.....	386	4033.....	732

Visit product pages for additional size, anodize and color options.

Part Number Index

4041.....	332	4153.....	354	4303.....	294	4357.....	356
4042.....	329	4154.....	354	4304.....	308	4358.....	356
4051.....	744	4155.....	272	4305.....	235	4359.....	357
4053.....	745	4156.....	355	4306.....	234	4360.....	277
4055.....	746	4157.....	356	4307.....	233	4361.....	266
4061.....	254	4158.....	356	4308.....	306	4362.....	267
4080.....	281	4159.....	357	4309.....	305	4363.....	724
4081.....	280	4160.....	277	4310.....	270	4364.....	725
4101.....	298	4161.....	724	4311.....	304	4365.....	238
4107.....	233	4162.....	725	4312.....	271	4366.....	237
4108.....	282	4163.....	726	4313.....	726	4367.....	236
4110.....	260	4164.....	266	4315.....	261	4370.....	278
4111.....	304	4165.....	238	4316.....	260	4371.....	341
4112.....	271	4166.....	237	4317.....	739	4372.....	338
4113.....	294	4167.....	236	4318.....	741	4375.....	301
4114.....	308	4168.....	721	4319.....	740	4376.....	292
4115.....	295	4169.....	722	4320.....	253	4377.....	712
4116.....	739	4170.....	278	4321.....	721	4379.....	720
4117.....	235	4171.....	723	4322.....	722	4380.....	718
4118.....	234	4172.....	716	4323.....	723	4381.....	710
4119.....	283	4174.....	334	4324.....	742	4383.....	719
4120.....	253	4175.....	301	4325.....	274	4384.....	711
4121.....	306	4176.....	292	4326.....	257	4385.....	717
4122.....	305	4177.....	712	4327.....	258	4386.....	345
4123.....	270	4178.....	720	4328.....	259	4387.....	343
4124.....	741	4180.....	718	4329.....	256	4388.....	344
4125.....	274	4181.....	710	4330.....	263	4390.....	339
4126.....	257	4183.....	719	4331.....	262	4392.....	340
4127.....	258	4184.....	711	4332.....	325	4394.....	342
4128.....	259	4185.....	717	4333.....	733	4395.....	353
4129.....	256	4186.....	345	4334.....	327	4396.....	350
4130.....	740	4187.....	343	4335.....	276	4397.....	352
4131.....	742	4188.....	344	4336.....	326	4398.....	352
4132.....	325	4195.....	353	4337.....	734	4399.....	351
4133.....	733	4196.....	350	4338.....	328	4401.....	346
4134.....	327	4197.....	352	4339.....	735	4402.....	347
4135.....	276	4198.....	352	4340.....	269	4403.....	348
4136.....	326	4199.....	351	4341.....	268	4404.....	358
4137.....	734	4250.....	293	4342.....	736	4405.....	358
4138.....	328	4251.....	312	4343.....	716	4406.....	359
4139.....	735	4260.....	299	4345.....	265	4407.....	360
4140.....	269	4265.....	284	4346.....	264	4408.....	360
4141.....	268	4266.....	307	4347.....	738	4409.....	361
4142.....	736	4280.....	293	4348.....	737	4413.....	300
4143.....	262	4281.....	312	4349.....	349	4414.....	314
4145.....	264	4285.....	302	4350.....	251	4415.....	303
4147.....	738	4286.....	302	4351.....	252	4416.....	315
4148.....	737	4290.....	299	4352.....	255	4417.....	316
4149.....	349	4295.....	284	4353.....	354	4420.....	313
4150.....	251	4296.....	307	4354.....	354	4421.....	273
4151.....	252	4301.....	295	4355.....	272	4422.....	275
4152.....	255	4302.....	283	4356.....	355	4423.....	279

Visit product pages for additional size, anodize and color options.

Part Number Index

4424.....	743	4611.....	418	5900.....	775	6491.....	696
4425.....	713	4625.....	422	5910.....	777	6515.....	661
4426.....	714	4626.....	422	5920.....	777	6516.....	663
4427.....	715	4700.....	420	5930.....	777	6523.....	669
4428.....	727	4701.....	419	5940.....	777	6524.....	671
4429.....	728	4702.....	420	5950.....	775	6525.....	665
4430.....	729	5005.....	828	6000.....	903	6526.....	667
4431.....	730	5010.....	829	6001.....	904	6530.....	673
4432.....	731	5015.....	828	6002.....	904	6531.....	675
4433.....	732	5020.....	829	6003.....	904	6533.....	681
4441.....	332	5025.....	828	6004.....	904	6534.....	683
4442.....	329	5030.....	829	6005.....	902	6535.....	677
4451.....	744	5035.....	827	6010.....	901	6536.....	679
4453.....	745	5036.....	827	6020.....	902	6590.....	696
4455.....	746	5040.....	827	6030.....	903	6591.....	696
4461.....	254	5041.....	827	6040.....	901	6595.....	697
4468.....	334	5045.....	827	6050.....	902	6596.....	697
4480.....	281	5046.....	827	6055.....	904	6700.....	701
4481.....	280	5050.....	766	6060.....	904	6701.....	701
4483.....	590	5100.....	766	6065.....	903	6702.....	702
4486.....	581	5125.....	767	6066.....	904	6703.....	702
4487.....	582	5150.....	767	6067.....	904	6705.....	699
4488.....	554	5200.....	766	6069.....	904	6706.....	699
4489.....	553	5250.....	767	6070.....	905	6710.....	511
4490.....	504	5300.....	766	6073.....	904	6715.....	661
4491.....	504	5340.....	779	6075.....	905	6716.....	663
4503.....	320	5350.....	767	6076.....	905	6723.....	669
4504.....	321	5360.....	778	6080.....	903	6724.....	671
4505.....	243	5370.....	778	6087.....	900	6725.....	665
4506.....	242	5400.....	768	6089.....	900	6726.....	667
4509.....	319	5415.....	769	6090.....	901	6730.....	688
4510.....	239	5425.....	769	6095.....	901	6731.....	688
4511.....	322	5450.....	768	6100.....	901	6732.....	689
4512.....	323	5475.....	769	6105.....	902	6733.....	689
4513.....	324	5500.....	768	6110.....	903	6734.....	690
4514.....	244	5525.....	769	6111.....	900	6735.....	690
4515.....	245	5550.....	773	6115.....	905	6736.....	691
4518.....	250	5575.....	772	6117.....	907	6737.....	691
4519.....	248	5600.....	773	6120.....	905	6760.....	684
4520.....	249	5625.....	772	6121.....	905	6762.....	685
4521.....	240	5650.....	774	6130.....	905	6764.....	686
4522.....	241	5675.....	772	6131.....	905	6766.....	687
4523.....	246	5700.....	770	6135.....	905	6780.....	703
4524.....	247	5725.....	771	6136.....	905	6792.....	700
4600.....	417	5750.....	770	6160.....	906	6793.....	700
4601.....	417	5775.....	771	6415.....	661	6797.....	698
4605.....	418	5845.....	775	6416.....	663	6798.....	698
4606.....	418	5850.....	775	6423.....	669	6800.....	704
4607.....	418	5860.....	776	6424.....	671	6801.....	705
4608.....	418	5870.....	776	6425.....	665	6802.....	708
4609.....	418	5880.....	776	6426.....	667	6803.....	706
4610.....	418	5890.....	776	6490.....	696	6804.....	707

Visit product pages for additional size, anodize and color options.

Part Number Index

6805.....	704	7007.....	853	7066.....	860	7168.....	876
6806.....	704	7008.....	853	7067.....	853	7169.....	876
6807.....	704	7009.....	853	7068.....	871	7170.....	876
6808.....	511	7010.....	851, 852	7070.....	860	7171.....	895
6810.....	701	7012.....	851	7071.....	860	7172.....	895
6811.....	701	7013.....	851	7072.....	860	7173.....	895
6812.....	702	7014.....	853	7073.....	860	7174.....	898
6813.....	702	7015.....	853	7074.....	862	7175.....	897
6814.....	699	7016.....	853	7075.....	860	7176.....	879
6815.....	661	7017.....	853	7076.....	860	7177.....	897
6816.....	663	7020.....	851, 852	7079.....	862	7178.....	897
6817.....	699	7021.....	851	7080.....	863	7179.....	879
6823.....	669	7023.....	851	7081.....	863	7180.....	897
6824.....	671	7024.....	853	7082.....	862	7181.....	898
6825.....	665	7025.....	853	7083.....	862	7182.....	895
6826.....	667	7026.....	853	7084.....	863	7183.....	895
6830.....	673	7028.....	853	7085.....	860	7184.....	895
6831.....	675	7029.....	853	7086.....	863	7185.....	898
6833.....	681	7030.....	851	7087.....	860	7186.....	897
6834.....	683	7031.....	853	7090.....	863	7187.....	879
6835.....	677	7032.....	853	7092.....	862	7188.....	897
6836.....	679	7033.....	853	7093.....	863	7189.....	897
6847.....	780	7035.....	853	7094.....	862	7190.....	895
6850.....	704	7036.....	853	7095.....	876	7191.....	895
6851.....	706	7037.....	853	7098.....	869	7192.....	895
6852.....	707	7038.....	853	7099.....	869	7193.....	898
6860.....	684	7039.....	853	7100.....	876	7194.....	897
6862.....	685	7040.....	857	7101.....	869	7195.....	879
6864.....	686	7041.....	857	7102.....	869	7196.....	897
6866.....	687	7042.....	857	7103.....	869	7197.....	897
6870.....	688	7043.....	857	7104.....	869	7198.....	897
6871.....	688	7045.....	853	7105.....	875	7199.....	898
6872.....	688	7046.....	853	7106.....	875	7200.....	897
6873.....	689	7047.....	853	7110.....	868	7201.....	898
6874.....	689	7048.....	853	7117.....	857	7202.....	880
6875.....	689	7049.....	853	7118.....	857	7203.....	880
6876.....	690	7050.....	855	7150.....	876	7204.....	884
6877.....	690	7051.....	855	7151.....	876	7205.....	852
6878.....	690	7052.....	853	7152.....	897	7206.....	877
6879.....	691	7053.....	853	7153.....	876	7207.....	877
6881.....	703	7054.....	853	7155.....	876	7208.....	877
6883.....	691	7055.....	853	7156.....	897	7209.....	877
6884.....	691	7056.....	853	7157.....	898	7210.....	852
6892.....	700	7057.....	853	7158.....	897	7211.....	882
6893.....	700	7058.....	870	7159.....	897	7212.....	852
6897.....	698	7059.....	853	7161.....	886	7213.....	852
6898.....	698	7060.....	853	7162.....	895	7214.....	882
7000.....	851	7061.....	853	7163.....	895	7215.....	883
7001.....	852	7062.....	871	7164.....	895	7216.....	883
7003.....	851	7063.....	853	7165.....	760	7217.....	885
7005.....	851	7064.....	853	7166.....	898	7218.....	885
7006.....	853	7065.....	860	7167.....	876	7219.....	886

Visit product pages for additional size, anodize and color options.

Part Number Index

7221.....	878	7531.....	877	8231.....	830	8390.....	821
7222.....	878	7532.....	877	8232.....	830	8391.....	821
7224.....	852	7533.....	877	8233.....	830	8392.....	823
7231.....	881	7540.....	878	8235.....	830	8394.....	823
7232.....	881	7541.....	878	8236.....	830	8395.....	823
7233.....	881	7542.....	878	8240.....	830	8397.....	823
7234.....	881	7543.....	878	8241.....	830	8399.....	823
7235.....	881	7580.....	891	8303.....	821	8400.....	823
7236.....	881	7581.....	891	8304.....	821	8401.....	823
7240.....	864	7582.....	891	8305.....	823	8402.....	823
7241.....	865	7583.....	891	8306.....	823	8403.....	823
7243.....	865	7584.....	892	8307.....	821	8405.....	823
7244.....	864	7585.....	892	8308.....	821	8406.....	823
7245.....	865	7586.....	892	8310.....	821	8407.....	823
7246.....	864	7587.....	892	8311.....	821	8408.....	823
7247.....	865	7588.....	893	8313.....	823	8413.....	825
7248.....	864	7589.....	893	8314.....	823	8414.....	825
7256.....	858	7593.....	894	8315.....	821	8415.....	831
7257.....	858	7594.....	894	8316.....	821	8416.....	831
7300.....	875	7595.....	894	8317.....	821	8417.....	839
7301.....	875	7596.....	894	8318.....	821	8418.....	839
7302.....	875	7597.....	881	8319.....	823	8419.....	823
7305.....	866	7598.....	881	8320.....	821	8420.....	823
7310.....	852	7599.....	881	8321.....	821	8422.....	823
7311.....	883	7600.....	881	8322.....	821	8424.....	823
7312.....	883	7601.....	881	8323.....	821	8426.....	839
7313.....	889	7602.....	881	8325.....	821	8427.....	839
7315.....	867	8020.....	907	8326.....	821	8445.....	835
7320.....	884	8030.....	907	8327.....	821	8446.....	835
7400.....	692, 873	8110.....	824	8328.....	821	8448.....	835
7401.....	692, 873	8111.....	824	8330.....	821	8449.....	835
7500.....	878	8115.....	824	8331.....	821	8507.....	846
7501.....	878	8116.....	824	8335.....	821	8508.....	846
7502.....	882	8120.....	824	8336.....	821	8510.....	844
7503.....	882	8121.....	824	8337.....	821	8511.....	844
7504.....	880	8125.....	824	8338.....	821	8512.....	845
7505.....	880	8126.....	824	8340.....	821	8513.....	845
7507.....	896	8210.....	830	8341.....	821	8515.....	844
7508.....	896	8211.....	830	8342.....	821	8516.....	844
7509.....	896	8212.....	830	8343.....	821	8520.....	840
7510.....	889	8213.....	830	8345.....	821	8521.....	840
7511.....	896	8215.....	830	8346.....	821	8525.....	841
7512.....	896	8216.....	830	8360.....	821	8526.....	841
7513.....	898	8217.....	830	8361.....	821	8527.....	841
7514.....	898	8218.....	830	8365.....	821	8528.....	841
7515.....	885	8220.....	830	8366.....	821	8530.....	840
7516.....	885	8221.....	830	8370.....	821	8531.....	840
7520.....	890	8222.....	830	8371.....	821	8535.....	841
7521.....	890	8223.....	830	8375.....	821	8536.....	841
7522.....	887	8225.....	830	8376.....	821	8540.....	841
7523.....	887	8226.....	830	8385.....	821	8541.....	841
7530.....	877	8230.....	830	8386.....	821	8545.....	834

Visit product pages for additional size, anodize and color options.

Part Number Index

8546.....	834	8725.....	823	9351.....	628	12018.....	514
8547.....	834	8900.....	366	9355.....	505	12019.....	583
8548.....	834	8901.....	366	9356.....	505	12020.....	514
8550.....	836	9000.....	73, 189	9361.....	598	12021.....	514
8551.....	836	9005.....	73, 190	9700.....	73, 182	12022.....	515
8555.....	836	9010.....	73, 191	9701.....	73, 183	12024.....	514
8556.....	836	9015.....	73, 192	9705.....	73, 184	12026.....	802
8560.....	833	9025.....	73, 193	9706.....	73, 185	12027.....	802
8561.....	833	9030.....	73, 194	9725.....	73, 186	12028.....	627
8565.....	838	9035.....	73, 195	9726.....	73, 187	12030.....	287
8566.....	838	9110.....	790	9728.....	73, 188	12031.....	286
8567.....	838	9113.....	433	9740.....	760	12032.....	289
8568.....	838	9115.....	423	9750.....	848	12033.....	288
8570.....	847	9120.....	424	9755.....	790	12034.....	290
8575.....	847	9130.....	427	9760.....	421	12035.....	291
8580.....	842	9140.....	425	9820.....	762	12036.....	309
8581.....	842	9150.....	428	9821.....	762	12037.....	309
8582.....	842	9153.....	434	9822.....	762	12038.....	297
8583.....	842	9160.....	429	9823.....	762	12039.....	310
8584.....	843	9170.....	430	9824.....	762	12040.....	311
8585.....	843	9180.....	431	9825.....	762	12041.....	789
8586.....	843	9190.....	432	9826.....	762	12043.....	789
8587.....	843	9198.....	435	9827.....	762	12044.....	789
8591.....	837	9210.....	790	9828.....	762	12045.....	789
8592.....	837	9213.....	433	9829.....	762	12047.....	789
8593.....	837	9215.....	423	9830.....	762	12050.....	474
8594.....	837	9220.....	424	9831.....	762	12051.....	477
8600.....	826	9230.....	427	9840.....	760	12053.....	477
8601.....	826	9240.....	425	9841.....	760	12055.....	477
8605.....	826	9242.....	426	9842.....	760	12057.....	476
8606.....	826	9245.....	437	9843.....	760	12058.....	476
8610.....	845	9250.....	428	9844.....	760	12062.....	550
8611.....	845	9253.....	434	9845.....	760	12064.....	551
8620.....	832	9260.....	429	9846.....	760	12065.....	551
8621.....	832	9270.....	430	9847.....	760	12067.....	547
8625.....	832	9273.....	436	9848.....	760	12068.....	540
8626.....	832	9275.....	438	9860.....	763	12069.....	540
8630.....	832	9280.....	431	9861.....	763	12070.....	540
8631.....	832	9290.....	432	9862.....	763	12071.....	538
8635.....	832	9297.....	439	9863.....	763	12072.....	537
8636.....	832	9300.....	507	9864.....	763	12073.....	537
8703.....	823	9301.....	394	9865.....	763	12074.....	546
8704.....	823	9302.....	394	9866.....	763	12075.....	546
8710.....	823	9305.....	508	9867.....	763	12080.....	544
8711.....	823	9306.....	394	9868.....	763	12084.....	555
8713.....	823	9307.....	394	12000.....	560	12085.....	556
8714.....	823	9310.....	507	12004.....	794	12086.....	556
8720.....	823	9315.....	579	12006.....	796	12087.....	556
8721.....	823	9320.....	394	12013.....	794	12088.....	555
8722.....	823	9325.....	394	12015.....	812	12089.....	555
8723.....	823	9330.....	440	12016.....	812	12093.....	552
8724.....	823	9350.....	628	12017.....	514	12094.....	552

Visit product pages for additional size, anodize and color options.

Part Number Index

12095.....	539	12194.....	621	12286.....	788	13041.....	377
12096.....	552	12195.....	619	12287.....	788	13046.....	370
12097.....	557	12197.....	619	12290.....	787	13047.....	370
12098.....	547	12198.....	619	12298.....	787	13048.....	370
12099.....	547	12200.....	619	12300.....	808	13049.....	370
12101.....	535	12201.....	619	12302.....	787	13050.....	368
12102.....	535	12203.....	619	12303.....	787	13051.....	368
12104.....	535	12204.....	619	12305.....	787	13052.....	368
12105.....	535	12211.....	618	12306.....	787	13053.....	368
12107.....	547	12213.....	618	12307.....	787	13054.....	368
12108.....	547	12215.....	618	12314.....	803	13055.....	368
12110.....	536	12216.....	618	12315.....	803	13058.....	376
12111.....	536	12217.....	618	12316.....	803	13059.....	378
12113.....	536	12218.....	618	12317.....	803	13060.....	376
12114.....	536	12221.....	618	12319.....	801	13061.....	378
12116.....	547	12222.....	618	12320.....	801	13062.....	376
12117.....	547	12223.....	619	12321.....	801	13063.....	378
12119.....	535	12224.....	619	12322.....	543	13064.....	369
12120.....	535	12227.....	619	12326.....	543	13065.....	369
12122.....	535	12228.....	619	12327.....	543	13066.....	369
12123.....	535	12229.....	618	12328.....	807	13082.....	375
12125.....	547	12230.....	618	12390.....	619	13083.....	375
12126.....	547	12231.....	619	12392.....	619	13084.....	375
12128.....	535	12232.....	619	12394.....	619	13088.....	376
12129.....	535	12233.....	619	12396.....	619	13089.....	378
12131.....	535	12234.....	619	12400.....	619	13090.....	376
12132.....	535	12237.....	618	12402.....	619	13091.....	378
12134.....	547	12238.....	618	12408.....	619	13092.....	376
12136.....	547	12239.....	618	13001.....	223	13093.....	378
12137.....	536	12240.....	618	13003.....	394	13094.....	376
12139.....	536	12241.....	618	13004.....	394	13095.....	378
12140.....	536	12242.....	618	13006.....	394	13096.....	376
12142.....	536	12243.....	618	13018.....	374	13098.....	376
12145.....	572	12245.....	618	13021.....	374	13106.....	382
12146.....	572	12246.....	618	13022.....	370	13107.....	382
12147.....	572	12247.....	618	13023.....	370	13108.....	382
12162.....	549	12248.....	618	13024.....	370	13109.....	382
12164.....	549	12249.....	618	13025.....	370	13110.....	380
12165.....	549	12250.....	618	13027.....	375	13111.....	380
12166.....	549	12252.....	546	13028.....	375	13112.....	380
12167.....	761	12254.....	548	13029.....	375	13113.....	380
12168.....	622	12255.....	550	13030.....	377	13115.....	380
12170.....	616	12256.....	550	13031.....	375	13116.....	380
12172.....	616	12258.....	787	13032.....	375	13117.....	380
12174.....	616	12259.....	787	13033.....	377	13118.....	380
12176.....	616	12260.....	787	13034.....	375	13119.....	380
12178.....	616	12261.....	787	13035.....	375	13120.....	381
12181.....	617	12262.....	787	13036.....	377	13121.....	381
12182.....	616	12269.....	787	13037.....	375	13122.....	381
12185.....	617	12271.....	787	13038.....	377	13123.....	381
12186.....	616	12279.....	788	13039.....	375	13124.....	381
12192.....	620	12283.....	788	13040.....	375	13125.....	381

Visit product pages for additional size, anodize and color options.

Part Number Index

13127.....	381	14008.....	624	14083.....	291	14166.....	380
13129.....	381	14009.....	625	14085.....	291	14167.....	475
13130.....	381	14010.....	626	14086.....	296	14170.....	330
13132.....	381	14011.....	337	14088.....	296	14171.....	331
13133.....	381	14012.....	223	14089.....	309	14172.....	330
13134.....	401	14013.....	223	14092.....	291	14173.....	331
13135.....	401	14014.....	337	14095.....	309	14174.....	330
13136.....	401	14016.....	337	14098.....	297	14175.....	331
13137.....	401	14017.....	337	14099.....	297	14176.....	330
13138.....	401	14018.....	337	14100.....	297	14177.....	331
13139.....	401	14019.....	337	14101.....	297	14185.....	475
13140.....	401	14021.....	651	14102.....	297	14186.....	475
13141.....	401	14023.....	651	14103.....	297	14188.....	475
13142.....	401	14025.....	651	14104.....	310	14189.....	475
13143.....	401	14027.....	651	14105.....	310	14190.....	475
13144.....	401	14028.....	651	14107.....	793	14191.....	475
13145.....	401	14029.....	651	14108.....	793	14192.....	474
13146.....	401	14030.....	651	14110.....	793	14193.....	794
13147.....	401	14032.....	651	14111.....	311	14196.....	395
13148.....	401	14035.....	652	14112.....	318	33450.....	220
13169.....	401	14037.....	652	14113.....	317	33470.....	220
13170.....	401	14039.....	652	14114.....	317	33490.....	220
13171.....	401	14041.....	652	14117.....	335	33530.....	220
13172.....	401	14043.....	652	14118.....	226	11-2525.....	393
13173.....	401	14045.....	652	14120.....	285	11-4065.....	398
13174.....	401	14047.....	652	14121.....	793	11-4310.....	386
13175.....	401	14051.....	287	14122.....	371	11-4312.....	386
13176.....	401	14052.....	287	14123.....	793	11-4512.....	391
13177.....	401	14053.....	287	14124.....	371	11-4516.....	391
13178.....	401	14054.....	287	14125.....	371	11-4710.....	388
13179.....	379	14056.....	287	14126.....	371	11-4712.....	388
13180.....	379	14057.....	296	14127.....	371	11-5065.....	398
13181.....	379	14058.....	296	14128.....	371	11-5308.....	386
13182.....	379	14059.....	286	14129.....	371	11-5310.....	386
13183.....	213	14060.....	286	14130.....	371	11-5312.....	386
13184.....	212	14061.....	286	14131.....	371	11-5314.....	386
13185.....	213	14062.....	289	14136.....	225	11-5316.....	386
13186.....	212	14065.....	289	14137.....	225	11-5510.....	391
13187.....	223	14066.....	289	14138.....	475	11-5512.....	391
13188.....	223	14067.....	289	14139.....	475	11-5516.....	391
13189.....	224	14068.....	296	14140.....	475	11-5518.....	391
13190.....	224	14070.....	296	14142.....	475	11-5520.....	391
13192.....	224	14071.....	288	14143.....	475	11-5708.....	388
13193.....	221	14073.....	288	14148.....	475	11-5710.....	388
14000.....	624	14074.....	290	14156.....	399	11-5712.....	388
14001.....	625	14075.....	290	14157.....	588	11-5714.....	388
14002.....	624	14076.....	290	14159.....	371	11-5716.....	389
14003.....	625	14077.....	290	14160.....	588	11-6039.....	397
14004.....	624	14078.....	290	14161.....	379	11-6040.....	397
14005.....	625	14079.....	290	14162.....	380	11-6041.....	397
14006.....	624	14080.....	296	14164.....	380	11-6042.....	397
14007.....	625	14081.....	296	14165.....	380	11-6065.....	398

Visit product pages for additional size, anodize and color options.

Part Number Index

11-6310.....	386	13-3944.....	387	13-6712.....	389	17-8516.....	392
11-6312.....	386	13-3945.....	387	13-6716.....	389	17-8520.....	392
11-6314.....	386	13-3946.....	387	13-8065.....	398	17-8525.....	392
11-6316.....	386	13-3947.....	387	13-8312.....	386	17-8530.....	392
11-6318.....	386	13-3948.....	387	13-8316.....	387	17-8535.....	392
11-6320.....	386	13-3950.....	392	13-8320.....	387	17-8540.....	392
11-6510.....	391	13-3951.....	392	13-8325.....	387	19-1065.....	398
11-6512.....	391	13-3952.....	392	13-8416.....	388	19-2065.....	398
11-6514.....	391	13-3953.....	392	13-8425.....	388	19-6041.....	397
11-6516.....	391	13-3954.....	392	13-8512.....	392	19-6042.....	397
11-6518.....	391	13-3955.....	392	13-8516.....	392	19-6065.....	398
11-6520.....	391	13-3956.....	392	13-8518.....	392	19-6312.....	386
11-6525.....	391	13-3957.....	392	13-8520.....	392	19-6316.....	386
11-6530.....	391	13-3958.....	392	13-8522.....	392	19-6320.....	386
11-6535.....	391	13-5065.....	398	13-8525.....	392	19-6325.....	386
11-6540.....	391	13-5310.....	386	13-8530.....	392	19-6512.....	391
11-6714.....	389	13-5312.....	386	13-8535.....	392	19-6516.....	391
11-6716.....	389	13-5316.....	386	13-8540.....	392	19-6520.....	391
11-6718.....	389	13-5320.....	386	13-8550.....	392	19-6525.....	391
11-6720.....	389	13-5510.....	391	13-8712.....	389	19-8065.....	398
11-8065.....	398	13-5512.....	391	13-8716.....	389	19-8312.....	387
11-8312.....	386	13-5516.....	391	13-8720.....	389	19-8316.....	387
11-8316.....	387	13-5518.....	391	17-1065.....	398	19-8320.....	387
11-8318.....	387	13-5520.....	391	17-5310.....	386	19-8325.....	387
11-8320.....	387	13-5525.....	391	17-5312.....	386	19-8512.....	392
11-8325.....	387	13-5530.....	391	17-5316.....	386	19-8516.....	392
11-8512.....	392	13-5712.....	388	17-5510.....	391	19-8520.....	392
11-8516.....	392	13-6040.....	397	17-5512.....	391	19-8525.....	392
11-8518.....	392	13-6041.....	397	17-5516.....	391	19-8530.....	392
11-8520.....	392	13-6042.....	397	17-5520.....	391	19-8920.....	400
11-8525.....	392	13-6043.....	397	17-6041.....	397	19-8925.....	400
11-8530.....	392	13-6044.....	397	17-6042.....	397	19-8930.....	400
11-8535.....	392	13-6045.....	397	17-6065.....	398	19-8935.....	400
11-8540.....	392	13-6065.....	398	17-6310.....	386	19-8945.....	400
11-8716.....	389	13-6310.....	386	17-6312.....	386	20-2020.....	69, 131
11-8720.....	389	13-6312.....	386	17-6316.....	386	20-2040.....	69, 132
13-1520.....	392	13-6316.....	386	17-6320.....	386	20-2490.....	490
13-1525.....	392	13-6320.....	386	17-6410.....	388	20-2491.....	500
13-1716.....	389	13-6325.....	386	17-6412.....	388	20-2492.....	498
13-1914.....	396	13-6410.....	388	17-6416.....	388	20-2493.....	492
13-1922.....	396	13-6412.....	388	17-6510.....	391	20-2494.....	501
13-1957.....	393	13-6416.....	388	17-6512.....	391	20-2495.....	499
13-1993.....	393	13-6508.....	391	17-6516.....	391	20-2496.....	482
13-2065.....	398	13-6510.....	391	17-6520.....	391	20-2497.....	484
13-2247.....	396	13-6512.....	391	17-6712.....	389	20-2565.....	230
13-3753.....	393	13-6516.....	391	17-8312.....	387	20-2566.....	230
13-3758.....	399	13-6520.....	391	17-8316.....	387	20-2567.....	230
13-3759.....	399	13-6525.....	391	17-8320.....	387	20-2568.....	230
13-3940.....	386	13-6530.....	391	17-8325.....	387	20-2570.....	230
13-3941.....	387	13-6535.....	391	17-8416.....	388	20-2575.....	230
13-3942.....	387	13-6540.....	392	17-8425.....	388	20-3681.....	217
13-3943.....	387	13-6710.....	389	17-8512.....	392	20-3895.....	217

Visit product pages for additional size, anodize and color options.

Part Number Index

20-4040	69, 133	25-1961	362	25-2361	637	25-2798	748
20-4080	281	25-1962	364	25-2362	639	25-2816	793
20-4081	280	25-1964	367	25-2363	641	25-2817	793
20-4107	233	25-1966	372	25-2364	641	25-2818	793
20-4113	294	25-2015	785	25-2380	647	25-2819	793
20-4117	235	25-2025	785	25-2385	647	25-2820	793
20-4118	234	25-2028	785	25-2387	647	25-2821	793
20-4119	283	25-2059	510	25-2406	632	25-2828	796
20-4165	238	25-2062	558	25-2414	649	25-2830	532
20-4166	237	25-2064	525	25-2416	649	25-2831	531
20-4167	236	25-2065	526	25-2418	629	25-2835	533
20-4176	292	25-2066	527	25-2419	629	25-2837	530
20-7005	851	25-2067	509	25-2427	472	25-2838	529
20-7020	851	25-2071	542	25-2428	479	25-2841	533
20-7030	851	25-2073	519	25-2439	758	25-2843	817
20-7042	857	25-2074	521	25-2451	759	25-2844	817
20-7046	854	25-2075	520	25-2489	480	25-2850	818
20-7047	854	25-2076	522	25-2490	490	25-2882	558
20-7061	853	25-2077	523	25-2491	500	25-3085	383
20-7063	853	25-2078	524	25-2492	498	25-3086	383
20-7064	854	25-2081	541	25-2493	492	25-3094	214
20-7065	860	25-2086	545	25-2494	501	25-3096	215
20-7067	854	25-2099	812	25-2495	499	25-3183	218
20-7069	855	25-2112	792	25-2496	482	25-3204	367
20-7075	860	25-2113	792	25-2497	484	25-3206	367
20-7080	863	25-2114	792	25-2501	69, 135	25-3266	786
20-7082	862	25-2116	588	25-2502	69, 136	25-3272	785
20-7085	860	25-2118	588	25-2503	69, 137	25-3312	373
20-7090	863	25-2122	577	25-2504	69, 138	25-3313	373
20-7092	862	25-2128	637	25-2512	486	25-3363	212
20-7202	880	25-2129	637	25-2513	488	25-3369	216
20-7211	882	25-2131	639	25-2514	70, 140	25-3376	372
20-7215	883	25-2132	639	25-2521	494	25-3382	362
20-7231	881	25-2137	637	25-2522	502	25-3383	218
20-7311	883	25-2139	639	25-2523	496	25-3391	213
20-7504	880	25-2142	641	25-2524	503	25-3392	212
20-7507	896	25-2143	641	25-2525	69, 134	25-3396	213
20-7509	896	25-2151	750	25-2527	69, 139	25-3501	396
20-7512	880	25-2152	750	25-2550	70, 142	25-3502	397
20-7593	894	25-2154	752	25-2565	230	25-3503	397
20-7594	894	25-2157	758	25-2566	230	25-3625	395
20-7597	881	25-2159	752	25-2567	230	25-3626	395
20-8210	830	25-2177	588	25-2568	230	25-3681	217
20-8211	830	25-2186	610	25-2570	230	25-3682	217
20-8212	830	25-2192	614	25-2575	230	25-3766	786
20-8213	830	25-2193	615	25-2576	70, 143	25-3895	217
20-8515	844	25-2205	612	25-2750	517	25-3896	212
20-8516	844	25-2211	512	25-2751	518	25-4024	743
25-1941	363	25-2221	513	25-2752	517	25-4025	713
25-1951	363	25-2281	515	25-2753	518	25-4026	714
25-1954	367	25-2341	751	25-2761	571	25-4027	715
25-1956	372	25-2349	753	25-2796	747	25-4028	727

Visit product pages for additional size, anodize and color options.

Part Number Index

25-4029	728	25-4172	716	25-6730	688	25-7084	863
25-4030	729	25-4175	301	25-6731	688	25-7086	863
25-4031	730	25-4176	292	25-6732	689	25-7098	869
25-4032	731	25-4177	712	25-6733	689	25-7101	869
25-4033	732	25-4178	720	25-6734	690	25-7202	880
25-4051	744	25-4180	718	25-6735	690	25-7206	877
25-4053	745	25-4181	710	25-6736	691	25-7207	877
25-4055	746	25-4183	719	25-6737	691	25-7211	882
25-4080	281	25-4184	711	25-6760	684	25-7215	883
25-4081	280	25-4185	717	25-6762	685	25-7217	885
25-4107	233	25-4186	345	25-6764	686	25-7231	881
25-4108	282	25-4187	343	25-6766	687	25-7232	881
25-4111	304	25-4188	344	25-6780	703	25-7233	881
25-4112	271	25-4195	353	25-6792	700	25-7256	858
25-4113	294	25-4196	350	25-6793	700	25-7311	883
25-4114	308	25-4197	352	25-6797	698	25-7401	692, 874
25-4115	295	25-4198	352	25-6798	698	25-7502	882
25-4116	739	25-4199	351	25-6850	704	25-7504	880
25-4117	235	25-4250	293	25-6851	706	25-7507	896
25-4118	234	25-4260	299	25-6852	707	25-7509	896
25-4119	283	25-4265	284	25-7000	851	25-7515	885
25-4120	253	25-4286	302	25-7003	851	25-7530	877
25-4124	741	25-5010	70, 145	25-7005	851	25-7531	877
25-4125	274	25-5013	70, 141	25-7006	854	25-7581	891
25-4128	259	25-5050	70, 144	25-7007	854	25-7582	891
25-4129	256	25-6115	905	25-7008	854	25-7586	892
25-4132	325	25-6120	905	25-7009	854	25-7589	893
25-4133	733	25-6121	905	25-7012	851	25-7593	894
25-4134	327	25-6131	905	25-7013	851	25-7594	894
25-4135	276	25-6136	905	25-7036	854	25-7597	881
25-4136	326	25-6160	906	25-7037	854	25-7598	881
25-4137	734	25-6415	661	25-7038	854	25-7599	881
25-4138	328	25-6416	663	25-7039	854	25-8210	830
25-4139	735	25-6423	669	25-7042	857	25-8211	830
25-4140	269	25-6424	671	25-7043	857	25-8212	830
25-4141	268	25-6425	665	25-7046	854	25-8213	830
25-4148	737	25-6426	667	25-7047	854	25-8217	830
25-4149	349	25-6490	696	25-7051	855	25-8218	830
25-4150	251	25-6491	696	25-7061	854	25-8222	830
25-4151	252	25-6700	701	25-7062	871	25-8223	830
25-4152	255	25-6701	701	25-7063	854	25-8307	822
25-4153	354	25-6702	702	25-7064	854	25-8308	822
25-4154	354	25-6703	702	25-7066	860	25-8310	822
25-4155	272	25-6705	699	25-7067	854	25-8311	822
25-4156	355	25-6706	699	25-7070	860	25-8327	822
25-4165	238	25-6710	511	25-7071	860	25-8328	822
25-4166	237	25-6715	661	25-7072	860	25-8330	822
25-4167	236	25-6716	663	25-7073	860	25-8331	822
25-4168	721	25-6723	669	25-7074	862	25-8335	822
25-4169	722	25-6724	671	25-7079	862	25-8336	822
25-4170	278	25-6725	665	25-7081	863	25-8337	822
25-4171	723	25-6726	667	25-7083	862	25-8338	822

Visit product pages for additional size, anodize and color options.

Part Number Index

25-8360 822	30-3030 70, 146	30-7312 883	40-2094 521
25-8361 822	30-3060 70, 152	30-7314 888	40-2095 520
25-8370 822	30-3681 217	30-7505 880	40-2096 522
25-8371 822	30-3789 362	30-7508 896	40-2097 523
25-8445 835	30-3796 362	30-7511 896	40-2098 524
25-8446 835	30-3891 217	30-7512 896	40-2100 812
25-8515 844	30-4134 327	30-7522 887	40-2104 525
25-8516 844	30-4302 283	30-7523 887	40-2105 526
25-8520 840	30-4303 294	30-7532 877	40-2106 527
25-8521 840	30-4305 235	30-7533 877	40-2109 792
25-8525 841	30-4306 234	30-7595 894	40-2110 792
25-8526 841	30-4307 233	30-7596 894	40-2111 792
25-8527 841	30-4332 325	30-7600 881	40-2115 588
25-8528 841	30-4335 276	30-8220 830	40-2117 588
25-8547 834	30-4336 326	30-8221 830	40-2119 791
25-8548 834	30-4338 328	30-8230 830	40-2120 587
25-8550 836	30-4340 269	30-8231 830	40-2121 577
25-8551 836	30-4351 252	30-8515 844	40-2130 637
25-8567 838	30-4365 238	30-8516 844	40-2135 637
25-8568 838	30-4366 237	30-8630 832	40-2138 637
25-8580 842	30-4367 236	30-8631 832	40-2140 639
25-8581 842	30-4376 292	30-8635 832	40-2141 641
25-8584 843	30-4480 281	30-8636 832	40-2145 639
25-8585 843	30-4481 280	40-1961 362	40-2146 641
25-8610 845	30-6060 70, 153	40-1964 367	40-2147 631
25-8611 845	30-7010 851	40-1966 372	40-2148 634
25-8620 832	30-7020 851	40-1968 373	40-2150 750
25-8621 832	30-7030 851	40-1981 363	40-2153 750
25-8625 832	30-7034 872	40-1982 364	40-2155 752
25-8626 832	30-7044 857	40-1984 367	40-2156 758
25-8901 367	30-7045 854	40-1986 372	40-2160 752
30-1961 363	30-7048 854	40-1988 373	40-2165 642
30-2431 492	30-7053 882	40-2030 785	40-2170 643
30-2432 490	30-7055 854	40-2033 786	40-2175 643
30-2433 484	30-7056 854	40-2035 787	40-2178 588
30-2434 482	30-7059 854	40-2037 787	40-2180 645
30-2435 501	30-7060 854	40-2039 787	40-2206 612
30-2436 500	30-7065 860	40-2043 787	40-2210 512
30-2437 499	30-7075 860	40-2045 785	40-2220 513
30-2438 498	30-7080 863	40-2050 785	40-2280 516
30-2565 230	30-7082 862	40-2051 510	40-2290 515
30-2566 230	30-7085 860	40-2052 568	40-2340 751
30-2567 230	30-7090 863	40-2055 567	40-2350 753
30-2568 230	30-7092 862	40-2060 558	40-2365 637
30-2569 230	30-7203 880	40-2061 558	40-2366 639
30-2570 230	30-7208 877	40-2063 567	40-2367 641
30-2575 230	30-7209 877	40-2068 509	40-2390 647
30-3001 70, 147	30-7214 882	40-2079 559	40-2400 647
30-3002 70, 148	30-7216 883	40-2080 541	40-2407 632
30-3003 70, 149	30-7234 881	40-2085 545	40-2408 632
30-3004 70, 150	30-7246 855	40-2091 542	40-2409 632
30-3022 70, 151	30-7257 858	40-2093 519	40-2410 647

Visit product pages for additional size, anodize and color options.

Part Number Index

40-2415	649	40-2716	607	40-3283	372	40-4301	295
40-2417	649	40-2717	607	40-3286	362	40-4302	283
40-2420	629	40-2731	608	40-3290	400	40-4303	294
40-2421	478	40-2754	517	40-3310	373	40-4304	308
40-2422	478	40-2755	518	40-3311	373	40-4305	235
40-2423	478	40-2756	518	40-3346	384	40-4306	234
40-2425	472	40-2757	517	40-3348	384	40-4307	233
40-2426	629	40-2758	518	40-3354	213	40-4308	306
40-2430	479	40-2759	518	40-3359	212	40-4309	305
40-2431	492	40-2760	571	40-3361	213	40-4311	304
40-2432	490	40-2765	571	40-3362	212	40-4312	271
40-2433	484	40-2797	747	40-3368	222	40-4316	260
40-2434	482	40-2799	748	40-3370	216	40-4317	739
40-2435	501	40-2822	793	40-3389	218	40-4318	741
40-2436	500	40-2823	793	40-3500	396	40-4320	253
40-2437	499	40-2824	793	40-3503	397	40-4321	721
40-2438	498	40-2825	793	40-3628	395	40-4322	722
40-2440	758	40-2826	793	40-3629	395	40-4323	723
40-2441	758	40-2827	793	40-3650	389	40-4325	274
40-2450	759	40-2832	532	40-3679	217	40-4328	259
40-2488	480	40-2833	531	40-3680	217	40-4329	256
40-2515	486	40-2836	533	40-3767	786	40-4330	263
40-2516	488	40-2839	530	40-3891	217	40-4331	262
40-2517	494	40-2840	529	40-3897	212	40-4332	325
40-2518	502	40-2842	533	40-3913	374	40-4333	733
40-2519	496	40-2845	817	40-3914	374	40-4334	327
40-2520	503	40-2846	817	40-3915	374	40-4335	276
40-2525	231	40-2849	818	40-4001	71, 157	40-4336	326
40-2530	231	40-2876	795	40-4002	71, 158	40-4337	734
40-2535	231	40-2877	795	40-4003	71, 159	40-4338	328
40-2540	231	40-2880	558	40-4004	71, 160	40-4339	735
40-2545	231	40-2881	558	40-4012	72, 175	40-4340	269
40-2550	231	40-2884	561	40-4020	71, 166	40-4341	268
40-2555	231	40-2885	561	40-4030-Lite	71, 161	40-4343	716
40-2560	231	40-2886	561	40-4040	71, 156	40-4345	265
40-2561	231	40-2887	561	40-4040-Lite	71, 155	40-4346	264
40-2562	231	40-3087	383	40-4040-UL	71, 154	40-4348	737
40-2563	231	40-3088	383	40-4045-Lite	71, 165	40-4349	349
40-2564	231	40-3100	214	40-4080	71, 170	40-4350	251
40-2578	231	40-3102	215	40-4080-Lite	71, 169	40-4351	252
40-2579	231	40-3116	400	40-4080-UL	71, 168	40-4352	255
40-2580	231	40-3120	400	40-4082-Lite	71, 171	40-4353	354
40-2581	231	40-3126	400	40-4083-Lite	72, 172	40-4354	354
40-2700	605	40-3134	400	40-4084-Lite	72, 173	40-4355	272
40-2701	606	40-3189	218	40-4085-Lite	72, 174	40-4356	355
40-2704	605	40-3202	367	40-4093	71, 162	40-4361	266
40-2705	606	40-3203	367	40-4094	71, 163	40-4362	267
40-2708	605	40-3267	786	40-4096	71, 164	40-4365	238
40-2709	606	40-3273	573	40-4280	293	40-4366	237
40-2712	605	40-3274	785	40-4285	302	40-4367	236
40-2713	606	40-3278	363	40-4290	299	40-4370	278
40-2715	607	40-3282	372	40-4295	284	40-4372	338

Visit product pages for additional size, anodize and color options.

Part Number Index

40-4375	301	40-6533	681	40-7010	851	40-7218	885
40-4376	292	40-6534	683	40-7014	851	40-7234	881
40-4377	712	40-6535	677	40-7015	851	40-7235	881
40-4379	720	40-6536	679	40-7016	851	40-7236	881
40-4380	718	40-6590	696	40-7017	851	40-7257	858
40-4381	710	40-6591	696	40-7020	851	40-7312	883
40-4383	719	40-6595	697	40-7021	851	40-7320	884
40-4384	711	40-6596	697	40-7023	851	40-7400	692, 874
40-4385	717	40-6800	704	40-7024	854	40-7503	872
40-4386	345	40-6801	705	40-7025	854	40-7505	880
40-4387	343	40-6802	708	40-7026	854	40-7508	896
40-4388	344	40-6803	706	40-7028	854	40-7511	896
40-4390	339	40-6804	707	40-7029	854	40-7512	896
40-4394	342	40-6805	704	40-7030	847	40-7516	885
40-4395	353	40-6806	704	40-7031	851	40-7522	887
40-4396	350	40-6807	704	40-7032	854	40-7523	887
40-4397	352	40-6808	511	40-7033	854	40-7532	877
40-4398	352	40-6810	701	40-7044	857	40-7533	877
40-4399	351	40-6811	701	40-7045	854	40-7580	891
40-4424	743	40-6812	702	40-7048	854	40-7583	891
40-4425	713	40-6813	702	40-7049	857	40-7584	892
40-4426	714	40-6814	699	40-7050	855	40-7585	892
40-4427	715	40-6815	661	40-7053	854	40-7588	893
40-4428	727	40-6816	663	40-7054	854	40-7595	894
40-4429	728	40-6817	699	40-7055	854	40-7596	894
40-4430	729	40-6823	669	40-7056	854	40-7600	881
40-4431	730	40-6824	671	40-7058	870	40-7601	881
40-4432	731	40-6825	665	40-7059	854	40-7602	881
40-4433	732	40-6826	667	40-7060	854	40-8016	72, 177
40-4441	333	40-6830	673	40-7065	860	40-8020	71, 167
40-4443	332	40-6831	675	40-7068	871	40-8080	72, 176
40-4451	744	40-6833	681	40-7075	860	40-8220	830
40-4453	745	40-6834	683	40-7076	860	40-8221	830
40-4455	746	40-6835	677	40-7080	863	40-8230	830
40-4480	281	40-6836	679	40-7082	862	40-8231	830
40-4481	280	40-6860	684	40-7085	860	40-8235	830
40-4488	554	40-6862	685	40-7087	860	40-8236	830
40-4489	553	40-6864	686	40-7090	863	40-8320	822
40-6060	906	40-6866	687	40-7092	862	40-8321	822
40-6070	905	40-6870	688	40-7093	863	40-8322	822
40-6075	905	40-6871	688	40-7094	862	40-8323	822
40-6076	905	40-6873	689	40-7099	869	40-8325	822
40-6130	905	40-6874	689	40-7102	869	40-8326	822
40-6135	905	40-6876	690	40-7110	868	40-8340	822
40-6515	661	40-6877	690	40-7115	857	40-8341	822
40-6516	663	40-6879	691	40-7116	857	40-8345	822
40-6523	669	40-6881	703	40-7203	880	40-8346	822
40-6524	671	40-6883	691	40-7204	884	40-8375	822
40-6525	665	40-6892	700	40-7208	877	40-8376	822
40-6526	667	40-6893	700	40-7209	877	40-8385	822
40-6530	673	40-6897	698	40-7214	882	40-8386	822
40-6531	675	40-6898	698	40-7216	883	40-8390	822

Visit product pages for additional size, anodize and color options.

Part Number Index

40-8391	822	45-4303	294	45-7512	896	65-2182	611
40-8448	835	45-4304	308	45-7522	887	65-2183	611
40-8449	835	45-4305	235	45-7523	887	65-2184	611
40-8510	844	45-4306	234	45-7534	877	65-2187	610
40-8511	844	45-4307	233	45-7535	877	65-2188	610
40-8512	845	45-4332	325	45-7595	894	65-2189	610
40-8513	845	45-4334	327	45-7596	894	65-2190	614
40-8530	840	45-4335	276	45-7603	881	65-2191	615
40-8531	840	45-4336	326	45-7604	881	65-2195	615
40-8535	841	45-4338	328	45-7605	881	65-2200	614
40-8536	841	45-4340	269	45-8220	830	65-2201	615
40-8540	841	45-4351	252	45-8221	830	65-2202	614
40-8541	841	45-4355	272	45-8230	830	65-2207	613
40-8545	834	45-4365	238	45-8231	830	65-2208	613
40-8546	834	45-4366	237	45-8235	830	65-2209	613
40-8555	836	45-4367	236	45-8236	830	65-2212	614
40-8556	836	45-4376	292	45-8320	822	65-2213	614
40-8565	838	45-4480	281	45-8321	822	65-2215	613
40-8566	838	45-4481	280	45-8340	822	65-2230-BLU	809
40-8582	842	45-4545	72, 179	45-8341	822	65-2230-RED	809
40-8583	842	45-4545-Lite	72, 178	45-8510	844	65-2230-YEL	809
40-8586	843	45-4590	72, 180	45-8511	844	65-2240-BLU	809
40-8587	843	45-7010	851	45-8630	832	65-2240-RED	809
40-8630	832	45-7020	851	45-8631	832	65-2240-YEL	809
40-8631	832	45-7024	854	45-8635	832	65-2250-BLU	809
40-8635	832	45-7030	851	45-8636	832	65-2250-RED	809
40-8636	832	45-7032	854	45-9090	72, 181	65-2250-YEL	809
40-8900	367	45-7034	872	65-2053	574	65-2264	810
45-2053	574	45-7035	854	65-2054	470	65-2265	810
45-2107	575	45-7036	854	65-2056	564	65-2270-BLU	809
45-2431	492	45-7037	872	65-2057	585	65-2270-RED	809
45-2432	490	45-7053	854	65-2058	564	65-2270-YEL	809
45-2433	484	45-7054	854	65-2069	576	65-2271-BLU	809
45-2434	482	45-7058	870	65-2070	563	65-2271-RED	809
45-2435	501	45-7065	860	65-2082	569	65-2271-YEL	809
45-2436	500	45-7075	860	65-2083	569	65-2272-BLU	809
45-2437	499	45-7080	863	65-2084	545	65-2272-RED	809
45-2438	498	45-7082	862	65-2087	570	65-2272-YEL	809
45-2525	232	45-7090	863	65-2088	576	65-2282	515
45-2530	232	45-7092	862	65-2089	570	65-2312	601
45-2535	232	45-7110	868	65-2090	579	65-2314	601
45-2540	232	45-7204	884	65-2101	525	65-2316	601
45-2545	232	45-7233	881	65-2102	526	65-2317	599
45-2550	232	45-7237	881	65-2103	527	65-2318	599
45-2555	232	45-7239	881	65-2107	575	65-2321	600
45-2560	232	45-7248	855	65-2108	813	65-2323	600
45-2561	232	45-7317	888	65-2123	578	65-2333	603
45-2562	232	45-7320	884	65-2125	576	65-2334	603
45-2563	232	45-7323	888	65-2126	573	65-2335	604
45-2564	232	45-7506	880	65-2178	611	65-2336	604
45-4301	295	45-7508	896	65-2179	611	65-2337	602
45-4302	283	45-7511	896	65-2181	611	65-2338	602

Visit product pages for additional size, anodize and color options.

Part Number Index

65-2340.....	597	65-2602.....	450	65-2658.....	461	65-2953.....	569
65-2341.....	597	65-2603.....	450	65-2659.....	462	65-2957.....	570
65-2342.....	597	65-2604.....	450	65-2660-S.....	456	65-2959.....	570
65-2343.....	597	65-2605.....	450	65-2660-T.....	456	65-3058.....	389
65-2344.....	597	65-2606.....	450	65-2661-S.....	456	65-3059.....	385
65-2345.....	597	65-2607.....	450	65-2661-T.....	456	65-3061.....	385
65-2346.....	597	65-2608.....	450	65-2662-S.....	456	65-3062.....	389
65-2424.....	586	65-2609.....	453	65-2662-T.....	456	65-3063.....	385
65-2429.....	586	65-2610.....	453	65-2663-S.....	456	65-3064.....	390
65-2452.....	464	65-2611.....	453	65-2663-T.....	456	65-3065.....	385
65-2453.....	464	65-2612.....	453	65-2664.....	462	65-3067.....	389
65-2454.....	464	65-2613-S.....	455	65-2666.....	461	65-3071.....	390
65-2455.....	464	65-2613-T.....	455	65-2667.....	461	65-3104.....	385
65-2456.....	464	65-2614-S.....	455	65-2668.....	461	65-3106.....	390
65-2457.....	464	65-2614-T.....	455	65-2669.....	461	65-3110.....	390
65-2460.....	468	65-2615.....	457	65-2714.....	607	65-3111.....	385
65-2461.....	468	65-2616.....	457	65-2730.....	566	65-3112.....	390
65-2462.....	468	65-2617.....	457	65-2745.....	580	65-3114.....	385
65-2463.....	468	65-2618.....	457	65-2763.....	571	65-3118.....	385
65-2464.....	468	65-2619.....	457	65-2780.....	565	65-3122.....	390
65-2465.....	592	65-2620.....	457	65-2781.....	565	65-3123.....	390
65-2467.....	468	65-2621.....	457	65-2782.....	565	65-3208.....	398
65-2468.....	468	65-2622.....	457	65-2800.....	466	65-3214.....	398
65-2470.....	468	65-2623.....	457	65-2802.....	466	65-3258.....	397
65-2471.....	468	65-2624.....	457	65-2804.....	466	65-3260.....	397
65-2472.....	469	65-2629.....	453	65-2806.....	466	65-4486.....	581
65-2473.....	469	65-2630.....	453	65-2808.....	463	65-4487.....	582
65-2474.....	469	65-2631.....	457	65-2810.....	481	65-4490.....	504
65-2475.....	469	65-2632.....	457	65-2812.....	461	65-4491.....	504
65-2476.....	469	65-2633.....	459	65-2813.....	461	65-4503.....	320
65-2477.....	469	65-2634.....	459	65-2814.....	463	65-4504.....	321
65-2478.....	469	65-2635.....	459	65-2815.....	463	65-4505.....	243
65-2479.....	468	65-2636.....	459	65-2851.....	816	65-4506.....	242
65-2480.....	467	65-2637.....	459	65-2852.....	816	65-4509.....	319
65-2481.....	467	65-2640.....	460	65-2899.....	797	65-4510.....	239
65-2482.....	467	65-2641.....	451	65-2901.....	623	65-4512.....	323
65-2483.....	465	65-2642.....	451	65-2902.....	623	65-4513.....	324
65-2484.....	465	65-2643.....	453	65-2903.....	623	65-6068.....	904
65-2485.....	465	65-2644.....	453	65-2904.....	623	65-6071.....	904
65-2500.....	804	65-2645.....	453	65-2905.....	623	65-6086.....	900
65-2501.....	804	65-2646.....	454	65-2906.....	623	65-6088.....	900
65-2502.....	804	65-2647.....	454	65-2907.....	623	65-6091.....	901
65-2503.....	804	65-2648.....	452	65-2908.....	623	65-6092.....	901
65-2504.....	804	65-2649.....	452	65-2922.....	569	65-6096.....	901
65-2505.....	804	65-2650.....	458	65-2923.....	569	65-6097.....	901
65-2506.....	805	65-2651.....	461	65-2927.....	570	65-6098.....	901
65-2507.....	805	65-2652.....	461	65-2929.....	570	65-6099.....	901
65-2508.....	805	65-2653.....	461	65-2932.....	569	65-6102.....	902
65-2509.....	805	65-2654.....	461	65-2933.....	569	65-6103.....	902
65-2510.....	805	65-2655.....	461	65-2937.....	570	65-6104.....	902
65-2511.....	805	65-2656.....	461	65-2939.....	570	65-6106.....	900
65-2601.....	450	65-2657.....	461	65-2952.....	569	65-6107.....	903

Visit product pages for additional size, anodize and color options.

Part Number Index

65-6108	903	65-7212	852	75-3423	414	75-3477	411
65-6109	903	65-7221	878	75-3425	413	75-3478	414
65-7095	876	65-7222	878	75-3426	414	75-3479	415
65-7100	876	65-7224	852	75-3427	414	75-3480	411
65-7150	876	65-7240	864	75-3428	415	75-3481	416
65-7151	876	65-7241	865	75-3429	415	75-3482	411
65-7152	897	65-7243	865	75-3430	415	75-3483	416
65-7153	876	65-7244	864	75-3431	415	75-3500	414
65-7155	876	65-7245	865	75-3432	415	75-3501	414
65-7156	897	65-7246	864	75-3433	415	75-3502	414
65-7157	898	65-7247	865	75-3434	415	75-3503	414
65-7158	897	65-7248	864	75-3435	411	75-3504	414
65-7159	897	65-7305	866	75-3436	411	75-3505	412
65-7162	895	65-7313	889	75-3437	411	75-3506	414
65-7163	895	65-7315	867	75-3438	411	75-3507	412
65-7164	895	65-7500	878	75-3439	411	75-3508	414
65-7166	898	65-7501	878	75-3440	411	75-3509	411
65-7167	876	65-7510	889	75-3441	411	75-3510	411
65-7168	876	65-7513	898	75-3442	412	75-3511	411
65-7169	876	65-7514	898	75-3443	412	75-3512	413
65-7170	876	65-7520	890	75-3444	412	75-3513	413
65-7171	895	65-7521	890	75-3445	413	75-3514	413
65-7172	895	65-7540	878	75-3446	413	75-3515	411
65-7173	895	65-7541	878	75-3447	413	75-3516	411
65-7174	898	65-7542	878	75-3448	413	75-3517	411
65-7175	897	65-7543	878	75-3449	413	75-3518	411
65-7176	879	65-7587	892	75-3450	412	75-3519	411
65-7177	897	65-8415	831	75-3451	412	75-3520	412
65-7178	897	65-8416	831	75-3452	413	75-3521	412
65-7179	879	65-8570	847	75-3453	413	75-3522	412
65-7180	897	65-8575	847	75-3454	413	75-3523	413
65-7181	898	75-3400	416	75-3455	414	75-3524	413
65-7182	895	75-3401	416	75-3456	413	75-3525	413
65-7183	895	75-3404	411	75-3457	414	75-3526	413
65-7184	895	75-3405	411	75-3458	414	75-3527	414
65-7185	898	75-3406	411	75-3459	415	75-3528	413
65-7186	897	75-3407	411	75-3460	415	75-3529	414
65-7187	879	75-3408	411	75-3461	415	75-3530	415
65-7188	897	75-3409	411	75-3462	415	75-3531	415
65-7189	897	75-3410	411	75-3463	415	75-3533	415
65-7190	895	75-3411	412	75-3464	415	75-3534	415
65-7191	895	75-3412	412	75-3465	415	75-3535	415
65-7192	895	75-3413	412	75-3466	411	75-3536	415
65-7193	898	75-3414	413	75-3467	411	75-3537	416
65-7194	897	75-3415	413	75-3468	411	75-3538	416
65-7195	879	75-3416	413	75-3469	412	75-3539	416
65-7196	897	75-3417	413	75-3470	412	75-3540	416
65-7197	897	75-3418	413	75-3471	413	75-3541	412
65-7198	897	75-3419	412	75-3472	413	75-3552	416
65-7199	898	75-3420	412	75-3473	414	75-3556	416
65-7200	897	75-3421	413	75-3475	415	75-3558	416
65-7201	898	75-3422	413	75-3476	415	75-3562	416

Visit product pages for additional size, anodize and color options.

Part Number Index

75-3563 416	75-3616 412	75-3649 413	75-3824 407
75-3571 416	75-3617 414	75-3650 413	75-3825 407
75-3572 416	75-3618 414	75-3651 413	75-3826 407
75-3573 416	75-3619 413	75-3652 414	75-3827 407
75-3574 416	75-3620 415	75-3653 414	75-3828 408
75-3575 416	75-3621 415	75-3654 412	75-3829 407
75-3576 416	75-3622 411	75-3655 412	75-3830 408
75-3578 416	75-3623 415	75-3800 405	75-3831 408
75-3581 416	75-3624 415	75-3801 405	75-3832 407
75-3583 416	75-3625 415	75-3802 405	75-3833 407
75-3584 412	75-3626 415	75-3803 405	75-3834 408
75-3585 412	75-3627 415	75-3804 405	75-3835 407
75-3587 412	75-3628 412	75-3805 405	75-3836 408
75-3588 412	75-3629 414	75-3806 405	75-3837 408
75-3589 412	75-3630 415	75-3807 405	75-3838 409
75-3590 412	75-3632 403	75-3808 405	75-3839 409
75-3591 412	75-3633 403	75-3809 405	75-3840 409
75-3592 412	75-3634 415	75-3810 405	75-3841 409
75-3593 412	75-3635 403	75-3811 405	75-3842 409
75-3594 412	75-3636 403	75-3812 406	75-3843 409
75-3595 412	75-3637 403	75-3813 406	75-3844 410
75-3596 412	75-3638 403	75-3814 407	75-3845 410
75-3597 413	75-3639 412	75-3815 407	75-3846 409
75-3598 412	75-3640 411	75-3816 407	75-3847 409
75-3599 411	75-3641 411	75-3817 407	75-3848 409
75-3600 411	75-3642 411	75-3818 407	75-3849 409
75-3601 411	75-3643 411	75-3819 407	75-3850 410
75-3602 411	75-3644 412	75-3820 406	75-3851 410
75-3603 411	75-3645 412	75-3821 406	
75-3605 411	75-3647 412	75-3822 407	
75-3615 413	75-3648 414	75-3823 407	

Visit product pages for additional size, anodize and color options.

Product Type Index

INTRODUCTION, 2-48

- What is 80/20*, 2-5
- Made with 80/20 Stuff*, 6-28
- Peace of Mind*, 29-35
- One-Stop-Shop, 30
- 80/20 Difference, 31
- Ongoing Support, 31
- Customer Support, 32
- Local Distributor Network, 32
- Design Assistance, 33
- Free Design Tools, 34-35
- 80/20 Services, 36-44**
- 80/20 Builds, 36-37
- Custom Machining, 38-39
- Panel Shop, 40-41
- Metal Finishing, 42
- Standard Machining, 43
- Custom Packaging, 44
- Ordering Information, 45-47**
- Shipping Schedule, 45-46
- Preferred Carriers, 46
- Return Policy, 46
- Damaged or Lost Shipments, 46
- Warranty, 47

PROFILES, 49-196

- Profile Education, 54-65
- Profile Quick Reference, 66-73
- T-slot Profiles, 74-181
- Fractional Profiles, 74-130**
- 10-Series T-slot Profiles, 74-95
- 15-Series T-slot Profiles, 96-130
- Metric, 131-181**
- 20-Series T-slot Profiles, 131-133
- 25-Series T-slot Profiles, 134-145
- 30-Series T-slot Profiles, 146-153
- 40-Series T-slot Profiles, 154-177
- 45-Series T-slot Profiles, 178-181
- Ready Tube, 182-188
- Quick Frame, 189-195

FASTENING METHODS, 197-440

- Fastening Methods Education, 204-210

Internal Fasteners, 212-224

- Anchor Fasteners, 212-215**
- Standard Anchor Fastener Assemblies, 212
- Standard Anchor Fastener Cam Only, 213
- Short Double Anchor Fastener Assemblies, 214
- Long Double Anchor Fastener Assemblies, 215
- Butt Fasteners, 216**
- End Fasteners, 217-219**
- Standard End Fasteners, 217
- Single Tab End Fasteners, 218
- Double End Fasteners, 219
- Inside Corner Connectors, 220-222**
- Hidden Corner Connectors, 220
- Miter Connectors, 221
- 90° Inside Corner Connectors, 222
- Bolt Connectors, 223-224**
- Central Connectors and Cover Cap, 223
- Bolt Connector, 224

External Fasteners, 225-333

- Plate Connectors, 225
- 45 Degree Supports, 226-232**
- 45 Degree Support Connector, 226
- 45 Degree Support Assemblies, 227-232
- Straight Plates, 233-235**
- 2 Hole - Straight Flat Plates, 233
- 3 Hole - Straight Flat Plates, 234
- 4 Hole - Straight Flat Plates, 235
- Square Plates, 236**
- 4 Hole - Square Flat Plates, 236
- Rectangular Plates, 237-238**
- 6 Hole - Rectangular Flat Plates, 237
- 8 Hole - Rectangular Flat Plates, 238
- Transition Plates, 239-250**
- 2 Hole - Transition Flat Plates, 239-241
- 3 Hole - Transition Flat Plates, 242-243
- 4 Hole - Transition Flat Plates, 244-247
- 6 Hole - Transition Flat Plates, 248-249
- 8 Hole - Transition Flat Plates, 250
- Angled Plates, 251-267**
- 90° Angled Flat Plates, 251-259
- 15° Angled Flat Plates, 260-261
- 30° Angled Flat Plates, 262-263

Product Type Index

45° Angled Flat Plates, 264-265

60° Angled Flat Plate, 266-267

Tee Plates, 268-275

4 Hole - Tee Flat Plate, 268

5 Hole - Tee Flat Plate, 269

6 Hole - Tee Flat Plate, 270

7 Hole - Tee Flat Plate, 271

8 Hole - Tee Flat Plate, 272

11 Hole - Tee Flat Plate, 273

12 Hole - Tee Flat Plate, 274

16 Hole - Tee Flat Plate, 275

Cross Plates, 276-279

7 Hole - Cross Flat Plate, 276

12 Hole - Cross Flat Plate, 277

16 Hole - Cross Flat Plate, 278

20 Hole - Cross Flat Plate, 279

Right Angle Plates, 280-281

5 Hole - "L" Flat Plate, 280

5 Hole - "T" Flat Plate, 281

Corner Brackets, 282-318

2 Hole - Corner Brackets, 282-291

2 Hole - Corner Bracket Cover Caps, 286-291

3 Hole - Corner Brackets, 292-293

4 Hole - Corner Brackets, 294-299

4 Hole - Corner Bracket Cover Caps, 297

6 Hole - Corner Brackets, 300-307

8 Hole - Corner Brackets, 308-311

8 Hole - Corner Bracket Cover Caps, 309-311

9 Hole - Corner Brackets, 312

10 Hole - Corner Brackets, 313

12 Hole - Corner Brackets, 314-315

18 Hole - Corner Brackets, 316

3 Way - Corner Brackets, 317-318

Transition Corner Brackets, 319-324

2 Hole - Transition Corner Brackets, 319-320

4 Hole - Transition Corner Brackets, 321-323

8 Hole - Transition Corner Brackets, 324

Corner Gussets, 325-328

2 Hole - Gusseted Inside Corner Brackets, 325

4 Hole - Gusseted Inside Corner Brackets, 326-327

8 Hole - Gusseted Inside Corner Brackets, 328

Corner Connectors, 329-333

3 Way - Corner Connectors, 329, 331-333

2 Way - Corner Connectors, 330

Variable Angle Connectors, 334-361

Clamp Blocks, 334-335

Standard Angle Clamp Block, 334

Economy Angle Clamp Block, 335

2 Hole - Pivot Joints, 336-337

Pivot Plates, 338-342

3 Hole - Pivot Plates, 338-340

5 Hole - Pivot Plates, 341-342

Structural Pivots, 343-361

Structural Pivot Nubs, 343-345

Structural Right Angle Pivot Nubs, 346-348

Structural Pivot Arms, 349-351

Structural Pivot Assemblies, 352-361

Hardware, 362-404

T-Nuts, 362-384

Slide-In T-Nuts, 362-371, 382-383

T-Nut Holding Springs, 365

Roll-In T-Nuts, 372-378

Drop-In T-Nuts, 379-381

Nylon T-slot Nut, 384

Bolts, 385-396

Button Head Socket Cap Screws (BHSCS), 385-387

Flanged Button Head Socket Cap Screws (FBHSCS), 387-388

Flat Head Socket Cap Screws (FHSCS), 388-389

Socket Head Cap Screw (SHCS), 389-392

Low Head Socket Cap Screws (LHSCS), 393

Flanged Hex Head Bolt, 393

Connecting Screws, 394

Self Tapping Screws, 394

Self Drilling Screws, 394

Threaded Insert, 395

Bearing Pad Screws, 395

Shoulder Bolts, 396

Shoulder Bolt Assemblies, 396

Washers, 397

Hex Nuts, 398-399

T-Slot Studs, 400-404

Bolt Assemblies, 405-416

Ready Tube Connectors, 417-422

Quick Frame Connectors, 423-440

Product Type Index

ADDING PANELS & DOORS, 441-592

Panels & Doors Education, 445-449

Panel Types, 450-469

Plastic Panels, 450-463

Acrylic Panels, 450

Polycarbonate Panels, 451-454, 460

ABS Haircell Panels, 455

Kydex® Panels, 456

Expanded PVC Panels, 457

Alucobest™ Panels, 458

Alumalite™ Panels, 459

HDPE Panels, 461

HDPE Pegboard, 462

Phenolic Resin Panel, 463

Aluminum Plates, 464-465

Solid Aluminum Plates, 464

Diamond Tread Plate, 465

Laminated Tabletops, 466

Mesh Panels, 467-469

Expanded Metal Panels, 467

Wire Mesh Panels, 468-469

Panel Mounts, 470-508

Blocks & Clamps, 470-478

Detent Hinge Stoppers, 470

Panel Mount Blocks, 471-477

Quick Change Panel Clamps, 478

Brackets, 479-481

Panel Mount Brackets, 479

Roll-In Panel Mount Brackets, 480

Tabletop Fastening Kits, 481

Retainers, 482-508

Single Arm Panel Retainers, 482-485

Double Panel Retainers, 486-489

Single Arm Mesh Retainers, 490-493

Double Arm Mesh Retainers, 494-497

Backing Plates, 498-499

Single Arm Mesh Retainer Assemblies, 500-501

Double Arm Mesh Retainer Assemblies, 502-503

Panel Holders, 504

Snap On Panel Retainers, 505

Mesh Retainers, 506-507

Wire Mesh Fasteners, 508

Door Mounts, 509-557

Sliding, 509-513

Sliding Door Glides, 509-511

Door Slide Tracks, 512-513

Rolling, 514-518

Roller Wheels, 514-516

Roller Wheel Brackets, 517

Roller Wheel Assemblies, 518

Swinging, 519-557

Standard Lift-Off Hinges, 519-524

Lift-Off Hinge Assemblies, 525-527

Bi-fold Door Configurations, 528

Economy Lift-Off Hinges, 529-532

Economy Lift-Off Hinge Assemblies, 533

Concealed Hinges, 534

Plastic Lift-Off Hinges, 535-538

Dual Hand Lift-Off Hinges, 539

Adjustable Hinges, 540-541

Detent Hinges, 542-543

Constant Friction Hinges, 544

4 Hole - Aluminum Hinges, 545

Standard Plastic Hinges, 546-549

4 Hole - Zinc Hinges, 550, 553-556

Transition Hinges, 551

Standard Stainless Steel Hinges, 552

Lite Panel Hinges, 557

Door Accessories, 558-592

Handles, 558-571

Plastic Handles, 558-560, 564

Aluminum Handles, 561-562, 565

Steel Handles, 563

Locking Plastic Panel Grabber™ Handles, 566

Deluxe Door Handle and Mating Handles, 567-568

Furniture Style Handles, 569-570

Furniture Style Handle Pawl Kits, 571

Latches, 572-584

Slam Latches, 572

Velcro® Latches and Fasteners, 573

Deadbolt Latches, 574-575

Grabber™ Door Catches, 576

Grabber™ Door Mounting Plates, 577-578

Magnetic Door Catches and Brackets, 579-581

Product Type Index

Ball Catches, 582-583
Tension Ball Latches, 584

Sliding Door Locks, 585

Gaskets & Edging, 586-590

Panel Stiffeners, 586
Panel Gaskets, 587-588
Rubber Door Seals, 589
Wire Edge Covers, 590

Door Stops, 591-592

FLOOR TO FRAME COMPONENTS, 593-652

Floor to Frame Education, 595-596

Casters, 597-607

Swivel Casters, 597, 599-600, 603, 605
Furniture Style Casters, 598
Rigid Casters, 601, 604, 606
Triangular Top Plate Casters, 602
Leveling Casters, 607

Floor Locks, Glides, and Leveling Feet, 608-615

Adjustable Position Floor Locks, 608

Floor Glides, 609-611

Standard, 609
Economy, 610
Large Base Glide, 611

Leveling Feet, 612-615

Mighty Mount, 612
Anti-Vibration Mount, 613
Deluxe and Economy Leveling Feet, 614-615

Bases, Anchors & Threaded Stems, 616-623

Swivel Foot Bases, 616-617, 620-621
Swivel Foot Threaded Stems, 618-619
Trapezoid Base Anchor, 622
Wedge Floor Anchors, 623

Floor & End Brackets, 624-628

Base Plates, 629-652

Caster Base Plates, 629-633
Position Floor Lock Base Plates, 634-635
Tapped Base Plates, 636-641
Leveling Anchoring Base Plates, 642-645
Floor Mount Base Plates, 646-650
Die-Cast Tapped Base Plates, 651-652

ADD-ON COMPONENTS, 653-780

Linear Motion, 653-708

Linear Motion Education, 658-659

Bearings, 660-695

Standard Linear Bearings, 660-671
High-Cycle Linear Bearings, 672-683
UniBearings, 684-687
UniBearing Assemblies, 688-691
Linear Bearing Brake Hole Specifications, 692
UHMW-PE Engineering Specifications, 693-695

Bearing Pads, 696-702

Linear Bearing Pads, 696-697
T-Slot Insert Bearing Pads, 698
UniBearing™ Pads, 699-700
Bearing Pad Profiles, 701-702

Shims & Brakes, 703-708

Shims, 703
Linear Motion Brakes, 704-708

Dynamic Pivots, 709-748

Dynamic Pivots Education, 709
Dynamic Pivot Nubs, 710-715
Dynamic Pivot Arms, 716-717
Dynamic Pivot Assemblies, 718-732, 735-742, 744-746
Bracket Plates, 733-734, 743
Dynamic Pivot Handle Kits, 747-748

Manifolds, Rollers & Stoppers, 749-764

Pressure Manifolds Education, 749

Plates, Gaskets & O-rings, 750-759

3-Hole Feed Plates and Gasket, 750
2-Hole Stopper Plates, 751
5-Hole Feed Plates and Gasket, 752, 754
4-Hole Stopper Plates, 753
3-Hole Stopper Plates, 755
12-Hole Feed Plates and Gasket, 756
8-Hole Stopper Plates, 757
Access Plates, 758-759
O-rings, 758

Rollers, Rods & Stoppers, 760-764

Gravity Rollers & Blocks, 760-761
Connector Rods, 762
P-Tube Stoppers, 763
Building with Gravity Rollers, 764

Product Type Index

Stanchions, 765-780

Stanchions Education, 765

Bases, Plates & Blocks, 766-771, 773-777

Bases, 766-767, 776-777

Plates, 768-771

Blocks, 773-775

Clamps & Handles, 772, 778-780

Clamps, 772, 778-779

Clamp Handles, 780

FINISHING YOUR FRAME, 781-818

Finishing Your Frame Education, 783-784

End Caps and End Cap Hardware, 785-790

T-slot Covers, 791-795

Tread Strip, 796

Wire, Cable and Tube Management, 797-805

Wiremold® Power Strip, 806

Anodize Breaker, 807

Grounding Terminal, 808

Storage Bins and Hangers, 809-810

Adjustable Monitor Mounts, 811

Tool Hangers, 812-813

Tool and Cup Holders, 814-815

Clamps and Label Holders, 816-817

Rubber Bumpers, 818

STRUCTURAL SHAPES, 819-848

Structural Shapes Education, 820

Flat Stock Profiles, 821-822

Block Profiles, 823

Square / Rectangular Tube Profiles, 824

Inside Corner Connector Profile, 825

Stanchion Profiles, 826

Aluminum Tube Profiles, 827

Steel Tubes, 828

Steel Solid Round, 829

Angle Profiles, 830-831

45 Degree Gusset Profiles, 832

Deadbolt Latch Profile, 833

Standard Nub Profiles, 834

Right Angle Nub Profiles, 835

Hinge Profiles, 836

Roll-In Panel Mount Bracket Profiles, 837

Panel Mount Block Profiles, 838

Clamp Block Profiles, 839

Single Flange Bearing Profiles, 840

Double Flange Bearing Profiles, 841

Single Flange UniBearing Profiles, 842

Double Flange UniBearing Profiles, 843

Single Retainer Profiles, 844

Double Retainer Profiles, 845

Storage Bin Hanger Profile, 846

Panel Stiffener Profiles, 847

Tube Insert Profile, 848

MACHINING SERVICES, 849-898

Profile Machining, 851-875

Panel Machining, 876-896

Miscellaneous Panel Milling, 897-898

TOOLS, 899-908

Fastener/Hex Tool Size Reference, 899

Ball End Combo Tools, 900

Ball Driver and "L" Wrench Sets, 900

Ball End Power Bits, 901

Ball End "L" Hex Wrenches, 901

Cheater Pipes, 902

Ball End Hex Drivers, 902

"T" Handle and Combination Wrenches, 903

Six Lobe Tools, 904

Ball End Hex Sockets, 904

Access Hole Drills and Jigs, 905

Anchor Fastener Counterbore Cutters, 906

Soft Face Mallets, 906

Roll Pin Punch, 907

Attitude Lapel Pins, 907

Glossary

0 Degree Dynamic Pivot Nub	A connecting block that allows profiles to swing 180 degrees parallel to the mounting profile.
10 Series	80/20's family of T-slot profiles utilizing 1.0 inch and 0.5 inch centerlines.
15 Series	80/20's family of T-slot profiles utilizing 1.5 inch and 0.75 inch centerlines.
20 Series	80/20's family of T-slot profiles utilizing 20mm and 10mm centerlines.
25 Series	80/20's family of T-slot profiles utilizing 25mm and 12.5mm centerlines.
30 Series	80/20's family of T-slot profiles utilizing 30mm and 15mm centerlines.
40 Series	80/20's family of T-slot profiles utilizing 40mm and 20mm centerlines.
45 Series	80/20's family of T-slot profiles utilizing 45mm and 22.5mm centerlines.
45 Degree Support	Precut and assembled profiles with 45° miters that add strength to corner connections.
6105-T5	An aluminum alloy used in many 80/20 profiles. It offers high strength, excellent machinability, and a great aesthetic finish.
80/20 Builds.....	The project assembly division of 80/20 [®] Inc. There are three service levels; preloading, subassembly and full assembly.
90 Degree Flat Plate	A connecting plate used to make right angle connections of T-slot profiles.
90 Degree Dynamic Pivot Nub	A connecting block that allows profiles to swing 180 degrees perpendicular to the mounting profile.
ABS Haircell	Acrylonitrile Butadiene Styrene: decorative plastic sheet material.
Access Hole.....	A hole specifically located in the T-slots that allow access to tighten an end fastener.
Adjustable Hinge	A hinge with adjustable tension between the leaves.
Aesthetic.....	Tasteful, pleasing, or inventive.
Align-a-Groove	Shallow grooves running the length of some of 80/20 [®] 's T-slotted profiles that aid in aligning profiles during assembly.
Alucobest™	Two thin (.020") aluminum sheets bonded together with a polyethylene core.
Alumalite™	Two thin aluminum sheets bonded together with a corrugated polyallomer core.
Aluminum Extrusion.....	Aluminum bar produced by heating and pressing the aluminum material through a shaped opening in a die, forming a distinctive profile.
Anchor Fastener.....	A strong and adjustable fastener used to join two T-slotted profiles at right angles.
Anodize.....	A thin, protective electrochemical coating used on aluminum surfaces; can be clear or colored.
ASTM.....	The American Society for Testing Materials: organization that sets testing standards and methods for materials.
Attitude	Our positive, can-do disposition that sets 80/20 [®] apart from the rest of the competition.
AutoQuoterX™ II.....	80/20's free 64-bit accessible plugin used in conjunction with full versions of AutoCAD [®] .
BHSCS	Button Head Socket Cap Screw.
Black Chromate.....	A black, corrosion-resistant coating used on some ferrous screw products.
Black Zinc.....	A black, corrosion-resistant coating used on some metal products.
Bolt Assembly.....	A single part number that makes ordering combinations of fasteners easier and faster.
Bushing	A removable cylindrical lining for an opening used to limit the size of the opening, resist abrasion, or serve as a guide.
Butt Fastener.....	Connects profiles end-to-end for a strong, flush connection.
CAD	Computer Aided Design or Computer Aided Drafting.
Chamfer.....	To bevel off the right angled edge of a corner.
Cheater Pipe.....	An improvised breaker bar made from a length of pipe and a wrench, used to provide extra torque.
Clear Chromate.....	A clear, corrosion-resistant coating used on some ferrous metal products.
Coefficient of Friction.....	The amount of force between two materials rubbing against each other.

Glossary

Counterbore.....	A cylindrical, flat-bottomed hole drilled partially through a profile.
Countersink	To chamfer a screw hole to allow the screw head to remain level with the mounting surface.
Cross Clamp.....	A stanchion block used to connect two tubes at right angles.
Cross Flat Plate	A pre-drilled plate used to connect profiles that intersect at right angles.
Deburr.....	To remove a sharp edge from a machined surface.
Double Flange	A part with two opposing projections, commonly used for attachment to other surfaces.
Double T-Nut	A T-nut containing two threaded holes with centerlines that match those of flat plates, used to speed up assembly.
Drill Jig.....	A fixture used for drilling perpendicular access holes.
Drop Lock	An 80/20 T-slot profile design feature that consists of a 2° decline in the T-slot flange. When a fastener is tightened to or beyond the necessary torque, the flange will press up to the adjoining profile, creating pressure that tightly holds the two bars together.
Dynamic Pivot Nub.....	An anchoring block fastened to the T-slot allowing mounted profiles full 180-degree motion, perpendicular to or parallel with the T-slot.
End Cap.....	A black plastic cover for the profile end.
End Fastener.....	A connecting clip and screw that provides a clean, hidden 90° connection for T-slot profiles.
Ergonomics.....	An applied science concerned with arranging things people interact with efficiently and safely.
FBHSCS	Flanged Button Head Socket Cap Screw.
FDA.....	The United States Food and Drug Administration.
FHSCS	Flat Head Socket Cap Screw.
Flange	A rib or rim for strength, for guiding, or for attaching to another object.
Flange Mount Caster	A caster with a pre-drilled flange to mount to a base plate.
Flat Plate	A pre-drilled joining plate or corner bracket used to connect profiles.
Floor Mount Base Plate.....	A pre-drilled bracket assembly used to anchor an application to the floor.
Friction Hinge	A hinge that holds doors open at variable angles to provide hands-free access for vertical-lifting smaller doors.
Gusset.....	A supported 45-degree angled bracket used to connect profiles at right angles.
HDPE.....	High Density Polyethylene.
High Pressure Laminate.....	A high strength, durable material used for workstations, countertops, and other work surfaces.
Inside Corner Bracket.....	A pre-drilled angled fastener used to connect profiles at right angles.
Jam Nut	A hex nut used to fix the height position of a threaded leveling foot or caster in the end of a profile.
"L" Structural Pivot Arm	A pre-drilled angled fastener used to connect profiles to pivot nubs.
Leveling/Anchoring Base Plate.....	A pre-drilled and tapped plate used to mount both leveling feet and floor anchor bolts to a profile frame.
LHSCS.....	Low Head Socket Cap Screw.
Lift-Off Hinge	An aluminum hinge designed to allow door panels to be removed easily by lifting the door while open. It also utilizes two pin lengths to facilitate fast, easy door replacement.
Linear Bearing	A slide that allows in-line motion using the T-slotted frame as a rail, and UHMW-PE bearing pads as guides. Patented by 80/20 [®] .
Linear Bearing Brake Hole	A precisely located hole that allows for attachment of brake hardware to the bearing housing.
Linear Bearing Brake Kit.....	The hardware kit consisting of a handle, washer, and T-slot stud used to fix the position of a linear bearing.
Locking Grabber™ Handle	A cabinet latch used for panel doors that locks with a key.

Glossary

Mesh Retainer	An anchoring bracket that attaches wire cloth or expanded metal panels to a T-slot frame.
Miter Cut.....	An angled cut.
Mounting Block.....	Used to attach a hollow or solid round tube profile to a T-slot frame.
MW	Molecular Weight: used in measuring plastic density.
Neoprene.....	A black, hard rubber product.
Nylatron GS.....	An extruded plastic used in the manufacturing of 80/20 roller wheels.
Nylon	Any of several polymeric, thermoplastic amides formed into strong elastic thread by forcing a melt through fine jets.
Open Style Access Hole.....	Customer-specified locations for access holes used to tighten end fasteners.
OSHA.....	Occupational Safety and Health Administration.
Panel Mount Block.....	An adjustable mounting block, keyed to the T-slot, used to mount panels to a profile frame.
Panel Retainer	An anchoring bracket that attaches plastic or sheet panels to a T-slot frame.
Pawl.....	A rotating catch used to capture and hold a door shut.
Phenolic Resin.....	A decorative, durable surface with exceptional impact and scratch resistance.
Pivot.....	To turn or oscillate on. To rotate about a stationary point.
Pivot Bracket	A flat plate that allows a profile to pivot 90° or 180° relative to the mounting profile and lock in place.
Polycarbonate.....	An impact-resistant thermoplastic resin that is hard, tough, and moisture resistant. Trade names Lexan® or Makrolon® polycarbonate
Polyurethane	A tough flexible plastic with high load bearing properties used on some 80/20 casters.
Position Floor Lock.....	A braking device that prevents a frame on wheels from rolling.
Powder Coat.....	An electrostatically applied paint that provides superior protection.
Preload	To load fasteners onto a flat plate or bracket to speed up assembly.
Pressure Manifold Plate	A pre-drilled plate used with a gasket to form a pressurized air or fluid chamber inside the cavity of a T-slotted profile.
PVC	Polyvinyl Chloride: used in lightweight plastic sheet and snap-on panel gaskets.
Quick Frame™	80/20's economical, lightweight framing alternative, utilizing one-inch square aluminum tubing and nylon push-in corner connectors.
Ready Tube™	Aluminum framing system featuring prefabricated mounting holes.
RGA.....	Returned Goods Authorization: A number assigned by 80/20's customer service department to allow faster processing of a return shipment.
Dynamic Right Angle Pivot Nub.....	A connecting block that allows mounted profiles to swing 90 degrees parallel to or perpendicular to the attached T-slot.
Rigid Caster.....	A wheel that is intended for straight back and forth motion. It can be combined with a swivel caster to provide directional change.
Roller Wheel.....	A wheel, keyed to fit the 80/20 profile T-slot, allowing 80/20 profiles to be used as rails.
Rust.....	Oxidation commonly associated with steel products.
SS.....	Stainless Steel.
SHCS.....	Socket Head Cap Screw.
Single Flange.....	A material with one projection, commonly used for attachment to other surfaces.
Slotted Corner Bracket	A fastener used for connecting profiles at right angles. The slotted holes allow for easy adjustments.
Stanchion.....	A block used for mounting round tubes to a T-slotted frame, adding a fourth or fifth axis of mobility.
Swivel Caster.....	A wheel that enables pivot turns and instant response to directional change.
Tap.....	To add threads to an extruded hole in a T-slot profile.

Glossary

"T" Flat Plate.....	A pre-drilled plate used to connect profiles that intersect at right angles.
Threaded Stem Swivel Caster.....	A steerable wheel mounted to a frame by means of a threaded rod.
T-Nut.....	A special threaded flat screw nut designed to fit into the T-slot of 80/20® profiles.
Transition Bracket.....	A pre-drilled angled bracket designed to connect different series of profiles.
Transition Plate.....	A pre-drilled plate designed to connect different series of profiles.
Triple T-Nut.....	A T-nut with three threaded holes with centerlines that match those of flat plates, used to speed up assembly.
T-Slot Cover.....	A cover that fits in a T-slot channel to prevent dust and debris build up, cover wires and tubes, and add a polished look.
T-Slot Designation Chart.....	A diagram to assist in locating machining service points for 80/20® T-slotted profiles.
T-Slot Stud.....	A threaded bolt designed so that the bolt head fits into the T-slot of a profile, leaving the threaded end protruding.
T-Slot.....	An opening extruded into, or machined out of, a solid surface in the shape of a "T," designed to capture or hold in place fasteners that can be located anywhere along the surface of the material.
TYP.....	Typical.
USDA.....	United States Department of Agriculture.
UHMW.....	Ultra High Molecular Weight
UHMW-PE.....	Ultra High Molecular Weight Polyethylene: excellent abrasion-resistant material used for bearing pads.
Universal Dynamic Pivot Assembly.....	A connecting block assembly that allows mounted profiles to swing 180 degrees parallel to or perpendicular to the attached T-slot.
Universal Dynamic Pivot Nub.....	A connecting block that allows mounted profiles to swing 180 degrees parallel to or perpendicular to the attached T-slot.
Wire Duct.....	A one piece, flexible molded nylon duct for containing wires and tubes. Open slots allow for lead offs; pieces snap together end to end for continuous travel.
Zinc Plating.....	A bright silver or black corrosion-resistant coating used on some metal products.

WHAT IS YOUR VISION?

At 80/20 we firmly believe in putting the customer first, and making it easy every step of the way.

This core belief reverberates right down to our simple business model. Everything starts with you and your vision.

We take that vision and provide a simple bill of materials based on what you want.

**IF YOU CAN DREAM IT,
YOU CAN BUILD IT WITH 80/20!**

The possibilities are endless when it comes to building with 80/20. Whether your application is for work, home, business or the shop, no order is too big, or too small.

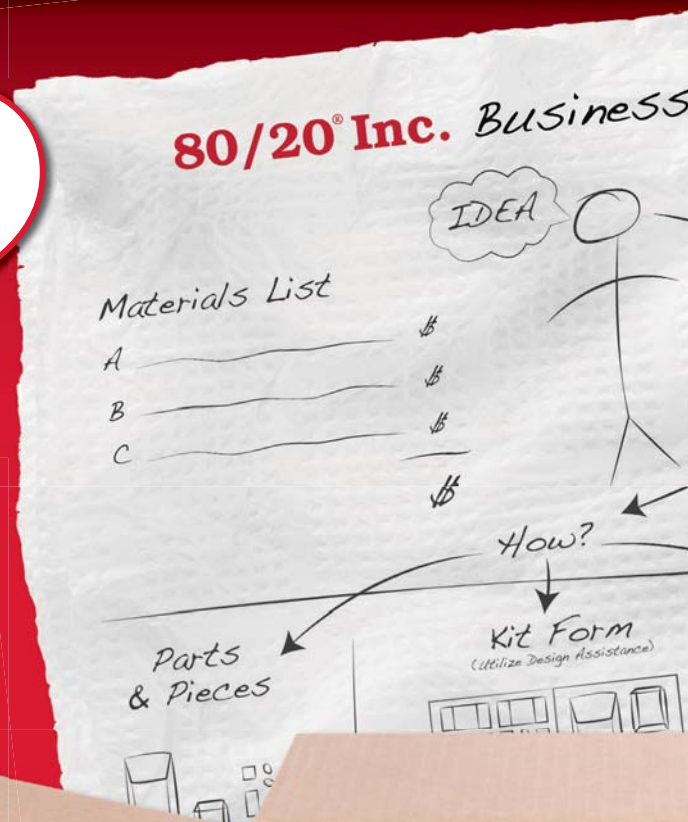

80/20

The Industrial

Model

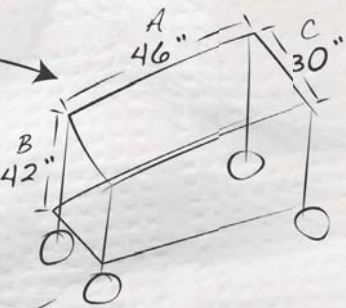

80/20 Builds
(Assembly Service)



3

**WAYS
TO
GET
IT**

Parts & Pieces

Materials shipped as parts and pieces ready for full assembly.

Kit Form

Materials packaged as a kit(s) and ready for easy assembly.

80/20 Builds

80/20 Technician Specialists partially or completely build your project, shipping it to you ready to go.

Need help getting started?

Get a quote from the 80/20 Design Assistance team. Call 260-248-8030 today and turn your idea into a real world solution!

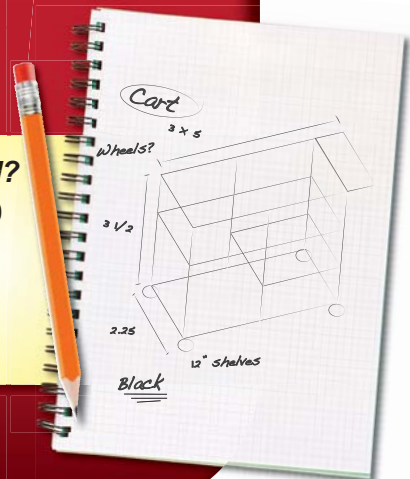

Inc.
Director Set™

See What's Being Made With 80/20

www.pinterest.com/8020stuff



Comment and Share Your Ideas

www.facebook.com/8020solutions



View Solutions & Helpful Tips Videos

www.youtube.com/8020inc



Follow News & Announcements

www.twitter.com/8020inc



Show Off Your 80/20 Creations

www.instagram.com/8020inc





See Pages 6-28 for Projects Made with 80/20!

SOLUTIONS FOR ANY INDUSTRY:

MACHINE TOOL
RETAIL SYSTEMS
COMPUTER RACKS
WORKSTATIONS
SCIENTIFIC

AUTOMATION
FURNITURE
CLEAN ROOMS
GUARDING
PACKAGING

MATERIAL HANDLING
FLUID POWER
ROBOTICS
LINEAR MOTION
ELECTRONICS

MANUFACTURING
DISPLAYS / EXHIBITS
EQUIPMENT TESTING
MEDICAL
AND MORE...



80/20
MOBILE APP



DOWNLOAD TODAY!

for iOS and Android Platforms



80/20 Inc.

The Industrial Erector Set®

Copyright © 2018 80/20 Inc. All rights reserved.
Catalog 22, Part No. L0418
1701 South 400 East, Columbia City, IN 46725
Ph: 260-248-8030 • Fax: 260-248-8029



To get the full story, visit

www.8020.net