

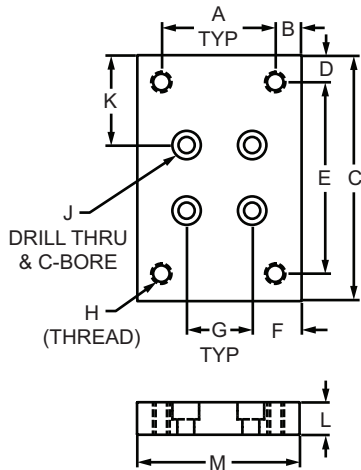

### Part Description:

The flange mount caster base plate is made of anodized aluminum to withstand daily use and wear and tear. It bolts to a profile end or side and is commonly used to mount casters for an added layer of strength and durability. It requires a tap (page 861) to mount to the profile end.



**2418, 2420**  
**25-2418, 40-2420**

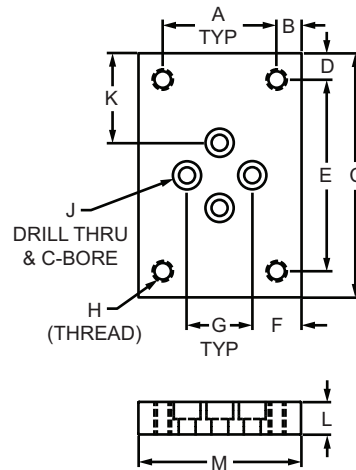

**2419, 2426**  
**25-2419, 40-2426**

Part No.	Series	A	B	C	D	E	F	G	H	J	K	L	M	Weight
2418	10	1.750"	.375"	3.750"	.405"	2.940"	.750"	1.000"	5/16-18	1/4 SHCS	1.375"	.500"	2.500"	.424 lb
2418-Black	10	1.750"	.375"	3.750"	.405"	2.940"	.750"	1.000"	5/16-18	1/4 SHCS	1.375"	.500"	2.500"	.424 lb
2419	10	1.750"	.375"	3.750"	.405"	2.940"	1.375"	1.000"	5/16-18	1/4 SHCS	1.375"	.500"	2.500"	.423 lb
2419-Black	10	1.750"	.375"	3.750"	.405"	2.940"	1.375"	1.000"	5/16-18	1/4 SHCS	1.375"	.500"	2.500"	.423 lb
2426	15	1.750"	.625"	3.750"	.405"	2.940"	.750"	1.500"	5/16-18	5/16 SHCS	1.125"	.750"	3.000"	.765 lb
2426-Black	15	1.750"	.625"	3.750"	.405"	2.940"	.750"	1.500"	5/16-18	5/16 SHCS	1.125"	.750"	3.000"	.765 lb
2420	15	1.750"	.625"	3.750"	.405"	2.940"	.750"	1.500"	5/16-18	5/16 SHCS	1.125"	.750"	3.000"	.762 lb
2420-Black	15	1.750"	.625"	3.750"	.405"	2.940"	.750"	1.500"	5/16-18	5/16 SHCS	1.125"	.750"	3.000"	.762 lb
25-2418	25	44.50mm	9.00mm	95.00mm	10.20mm	74.60mm	18.70mm	25.00mm	M8 x 1.25	M6 SHCS	35.00mm	12.00mm	62.50mm	.1800 kg
25-2418-Black	25	44.50mm	9.00mm	95.00mm	10.20mm	74.60mm	18.70mm	25.00mm	M8 x 1.25	M6 SHCS	35.00mm	12.00mm	62.50mm	.1800 kg
25-2419	25	44.50mm	9.00mm	95.00mm	10.20mm	74.60mm	18.75mm	25.00mm	M8 x 1.25	M6 SHCS	35.00mm	12.00mm	62.50mm	.1800 kg
25-2419-Black	25	44.50mm	9.00mm	95.00mm	10.20mm	74.60mm	18.75mm	25.00mm	M8 x 1.25	M6 SHCS	35.00mm	12.00mm	62.50mm	.1800 kg
40-2426	40	44.40mm	17.80mm	97.00mm	11.20mm	74.60mm	20.00mm	40.00mm	M8 x 1.25	M8 SHCS	28.50mm	19.00mm	80.00mm	.3648 kg
40-2426-Black	40	44.40mm	17.80mm	97.00mm	11.20mm	74.60mm	20.00mm	40.00mm	M8 x 1.25	M8 SHCS	28.50mm	19.00mm	80.00mm	.3648 kg
40-2420	40	44.40mm	17.80mm	97.00mm	11.20mm	74.60mm	20.00mm	40.00mm	M8 x 1.25	M8 SHCS	28.50mm	19.00mm	80.00mm	.3682 kg
40-2420-Black	40	44.40mm	17.80mm	97.00mm	11.20mm	74.60mm	20.00mm	40.00mm	M8 x 1.25	M8 SHCS	28.50mm	19.00mm	80.00mm	.3682 kg

CONTINUE

## Flange Mount Caster Base Plate (Continued)

### Material Specifications

Part No.	Material	Alloy*	Process	Finish
2418				Clear Anodize
2418-Black				Black Anodize
2419				Clear Anodize
2419-Black				Black Anodize
2426				Clear Anodize
2426-Black				Black Anodize
2420				Clear Anodize
2420-Black				Black Anodize
25-2418	Aluminum	6105-T5	Milled	Clear Anodize
25-2418-Black				Black Anodize
25-2419				Clear Anodize
25-2419-Black				Black Anodize
40-2426				Clear Anodize
40-2426-Black				Black Anodize
40-2420				Clear Anodize
40-2420-Black				Black Anodize

\* Or comparable

### Required Machining Services

Machining Type	Machined	Reference Page
Tap Profile End	Mount to Profile End	861

### Suggested Hardware (Mount to T-Slot)

Part No.	Series	Qty.	Bolt	T-Nut
3491	10	4	1/4-20 x 1/2" SHCS	Economy
3458	15	4	5/16-18 x 7/8" SHCS	Economy
75-3412	25	4	M6 x 12mm SHCS	Economy
75-3430	40	4	M8 x 20mm SHCS	Economy

### Suggested Hardware (Mount to Profile End)

Part No.	Series	Qty.	Bolt
3064	10	4	1/4-20 x 3/4" SHCS
3123	15	4	5/16-18 x 1.25" SHCS
13-6516	25	4	M6 x 16mm SHCS (Blue)
13-8525	40	4	M8 x 25mm SHCS (Blue)

### Mount to End of Profile

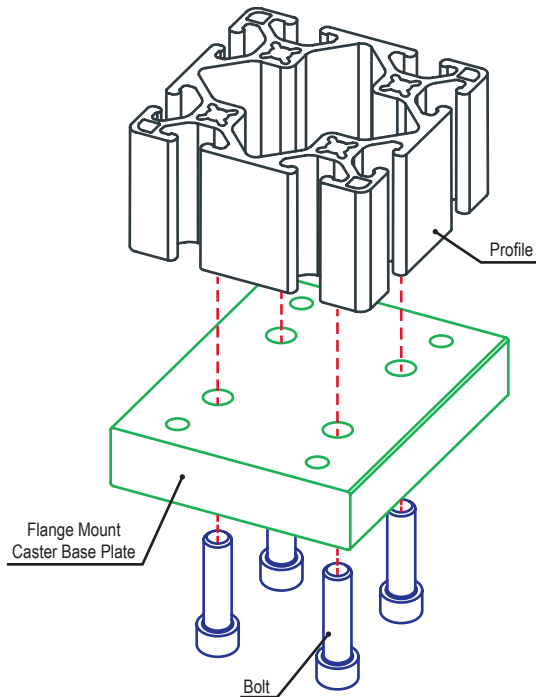

### Mount to T-Slot

